

Profile

- Version with two counters (4 or 5 decades) and fine reading
- Predestined for use with wood milling machines
- Hollow shaft, max. \varnothing 30 mm
- Display can be designed for "mm" or "inch"

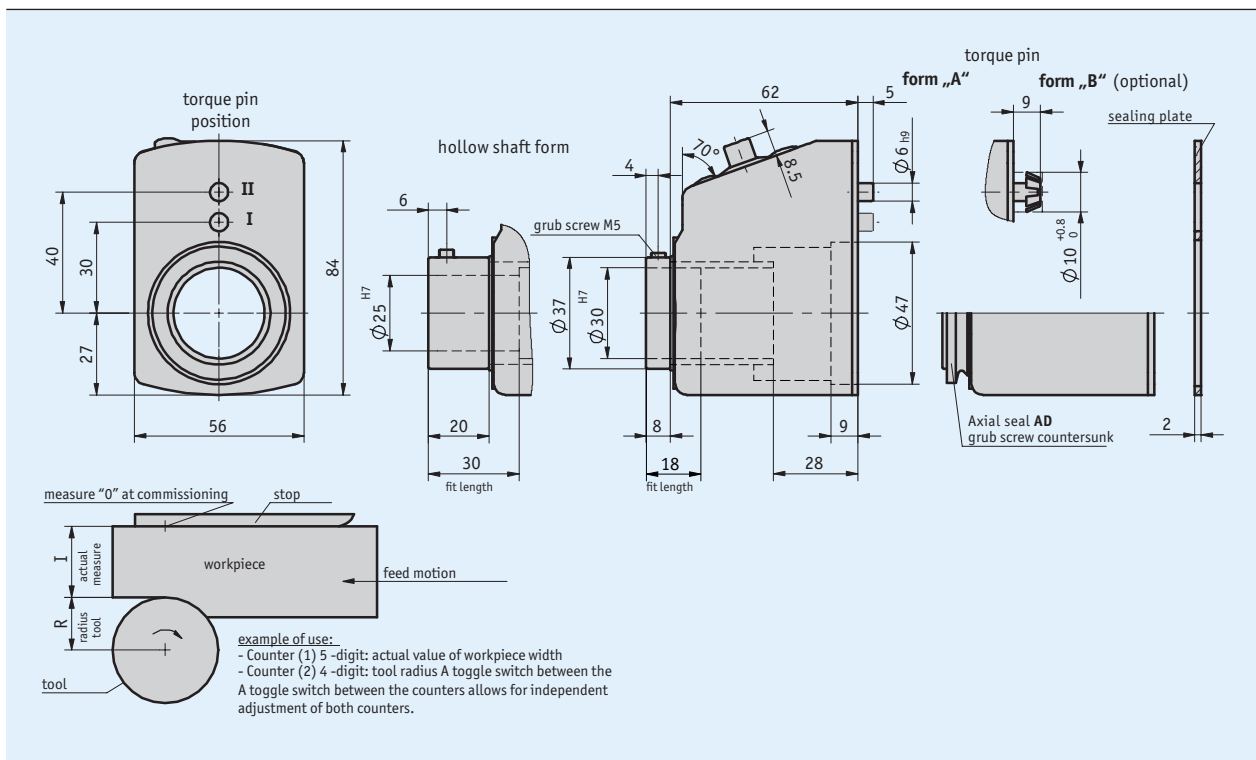

Mechanical data

Feature	Technical data	Additional information
Housing	reinforced plastic	
Counter	4 and 5 decades, fine reading	
Digit height	~7 mm	
Weight	0.1 kg	

■ **max. speed**

Display (after 1st revolution)	max. speed [rpm]
00010	500 (1500)
00015	500 (1000)
00020	500 (750)
00025	500 (600)
00030	500
00040	375
00050	300
00060	250
00080	180
00100	150

Formula:

$$\text{max. speed} = \frac{15000}{\text{indication after 1st revolution}}$$

 *Speeds >500 rpm must only be run for short periods.*

Ambient conditions

Feature	Technical data	Additional information
Ambient temperature	0 ... 80 °C	

Order

Ordering information

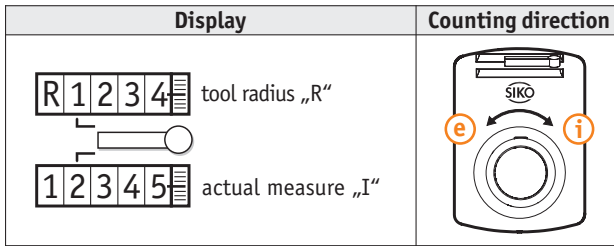

Hint: Texts highlighted in orange color are ordering features

Ordering table

Feature	Ordering data	Specification	Additional information
Indication after 1st revolution	... A	7/874, 10, 15/747, 20, 25, 39/368, 40, 50, 80, 100	/874 = nicht angezeigter rechnerischer Wert
Decimal place	0	0 = 0000	
	1	1 = 000.0	
	2	2 = 00.00	
	3	3 = 0.000	
Counting direction	i	clockwise ascending values	
	e	counter-clockwise ascending values	
Hollow shaft/diameter	... D	25, 30 RH20, RH25	reducing bushes
	WK WL	E	short hollow shaft long hollow shaft
Torque pin/position	I II	F	position I position II
	OAD AD	G	without axial seal with axial seal

Order key



Scope of delivery: DA10R/1

Accessories:
Reduction sleeve RH

www.siko-global.com