

DriveLine | Actuators





4.0 | Overview

Measurement technology since 1963	4
Press review User reports	6

4.1 Actuators	9
4.2 Accessories	55
4.3 Appendix	81
4.4 Product index, contact information	85

4.0

4.1

4.2

4.3

4.4



4.0

With a clear vision for the future!

Today SIKO can look back over five decades of experience in the production of measuring instruments for length, angle and speed measurement as well as the measurement of tilt angles and speed. With these core competencies as its foundation, SIKO develops and produces measuring instruments and positioning systems for automation and manufacturing processes that are geared to the future.

The highest demands of our customers from the industry and the mechanical engineering sector are more than met by the quality, precision and functionality of our products and services.

SIKO is certified to DIN EN ISO 9001 : 2008. In our company sustainable use of resources is a matter of course.

5 product ranges - a wide portfolio for very different measuring assignments

The SIKO product portfolio comprises a total of 5 ranges, including high-quality measuring instruments and positioning systems for the industry and the mechanical engineering sector.

We develop sensor systems for measured value acquisition either for you or in collaboration with your company. Shorter tooling times and the optimization of manufacturing and production processes are often the centre of focus.

OEM customers, projects and special solutions, retrofits or spare parts supplies directly to end users - all our customers are important!

5 distinctive product lines

PositionLine	mechanical and electronic position indicators, handwheels with analog displays, adjustment buttons
RotoLine	magnetic and optical rotary encoders, geared potentiometers
LinearLine	wire-actuated encoders
DriveLine	actuators
MagLine	magnetic length and angle measuring systems





4.0

Global success is never coincidental

Today the robust and innovative SIKO measuring instruments are in use in industrial and mechanical engineering installations around the world.

Five SIKO subsidiaries are at your disposal in the following countries:

- U.S.A.
- Italy
- Switzerland
- China
- Singapore

In addition, around 60 national and international agencies are on the spot for direct customer contact and technical support. Sales engineers and service technicians support OEM customers as well as users at their own facilities, providing competent advice and services in the respective national languages.



Horst Wandres & Sven Wischnewski | Management of SIKO GmbH



“The AGO2 drives do the same job in around 1.5 minutes – irrespective of whether only one axis is adjusted or all 14. In the latter case – 30 minutes compared to 1.5 minutes – we are 20 times faster with automatic format adjustment”.

Mr Salzani, Mechanical Department Manager at Vimco S.r.l.
Extract from A&D, February

“In addition, no more adjustment errors can occur with automated processes, the product quality is enhanced and off-spec products are minimized.”

Extract from A&D, February 2007



*“Automated actuators
Set-up times slashed by around 90 percent”*

Günther Herkommer, editor at computer-automation.de
online publication of 6 May 2014

TECHNIK • AUTOMATISIEREN

Reduzierte Rüstzeiten durch automatisierte Antriebe

Fischerwerke setzen auf den automatisierten Stellantrieb der Siko GmbH

Die automatisierbaren Stellantriebe des Ruchenbacher Traditionsunternehmens Siko führen zu einer Reduktion der Rüstzeiten in den Bereichen Maschinen- und Anlagenbau. Die Fischerwerke haben bereits Teile der Verpackungsfertigung auf die Stellantriebe umgestellt. Durch den Einsatz von etwa 50 Stellantrieben der Baureihe AG65 konnte Fischer ein gewisses Gewicht und kleinere Baugröße übertragen ohne Kunden die gewohnte Flexibilität in der Fertigung. Ohne sämtliche Positionen auf Lager halten zu müssen, kann kurzfristig auf eingehende Aufträge reagiert werden.

Die entscheidende Größe bei industriellen Produktionsprozessen ist die Stückzahl. Je größer diese ist, desto schneller können die Maschinen für den nächsten Auftrag umgestellt werden. Fischerwerke setzen auf die Flexibilität der Fischerwerke. So wird in vielen Metallbearbeitungs- und Maschinenbauarbeiten die Umstellung von einem Produkt zum nächsten durch die Automatisierung erleichtert. Die Fischerwerke setzen auf die Flexibilität der Fischerwerke. So wird in vielen Metallbearbeitungs- und Maschinenbauarbeiten die Umstellung von einem Produkt zum nächsten durch die Automatisierung erleichtert.



"We were able to lower set-up times from 45 minutes to below five. This is a tremendous increase in efficiency."

Herbert Erath, Head of Special Mechanical Engineering, Fischer (Fischer Dübel)
Extract from "konstruktionspraxis" October 2013

4.0

TECHNOLOGIE KARRIE
Günter Herkmann
in der Verpackungslinie von 10 Minuten senken. Damit



Individueller Look in Maßarbeit

Jeder kennt es zur Genüge: von dem Dreieck bis zum Kreis, von der Kugel bis zum Kegel. Die individuellen Anforderungen an die Maßarbeit sind vielfältig. Die Digitalisierung der Produktion ermöglicht es, die individuellen Anforderungen an die Maßarbeit zu erfüllen. Die Digitalisierung der Produktion ermöglicht es, die individuellen Anforderungen an die Maßarbeit zu erfüllen.



Wenn Sie das nächste Mal in einem Geschäft oder Hotel ein Schild sehen, das ein Mann in einem Anzug zeigt, dann ist das ein Zeichen für die Digitalisierung der Produktion. Die Digitalisierung der Produktion ermöglicht es, die individuellen Anforderungen an die Maßarbeit zu erfüllen.

Kundenorientierte Oberflächengestaltung
Die innovative Anlage vereint Wälzlager, Düsen-Trockenbürste (U-Ausleger) und Handlingsarme von Bürste mit einer Druck-Digitaldruckmaschine. Das SP gibt die Kombination mehrerer bisher unvereinbarer Möglichkeiten einer kundenspezifischen und individualisierten Oberflächengestaltung und -veredelung. Die Anlage arbeitet mit dem Single-Pass-Verfahren, während die nebenwirkende angrenzende Druckablage stark fließt sind. Bei Multi-Pass-Digitaldruckern im Bild gibt das optische Feedback der Druckerei über das optische Feedback der Druckerei über das optische Feedback der Druckerei.

Antrieb reduziert Rüstzeiten

Durch den Einsatz von etwa 50 Stellantrieben konnte ein Hersteller die Rüstzeiten mehrerer Produktionslinien auf unter fünf Minuten drücken.

Die entscheidende Größe bei industriellen Produktionsprozessen ist die Stückzahl. Je größer diese ist, desto schneller können die Maschinen für den nächsten Auftrag umgestellt werden. Fischerwerke setzen auf die Flexibilität der Fischerwerke. So wird in vielen Metallbearbeitungs- und Maschinenbauarbeiten die Umstellung von einem Produkt zum nächsten durch die Automatisierung erleichtert.



"With the changing workpiece formats it was essential for us that the actuators we use guarantee maximum precision and are good value for money."

Tobias Schreck, Product Manager, Coating Technology Robert Bürkle
Extract from "HoB special" May 2008"

4.1



4.0 | Overview 3

4.1 | Actuators

General information and areas of application	10
Technical details	12
Function and benefit	14
Product matrix	15
Products	
AG26 Fieldbus/IE	16
AG25 Fieldbus/IE	19
AG06 Fieldbus	22
AG05 Fieldbus	25
AG04B Fieldbus	28
AG03/1 Fieldbus	32
AG02 Fieldbus	36
AG02 Analog	39
AG02 Incremental	42
AG01 Analog	46
AG01 Incremental	50

4.2 | Accessories 55

4.3 | Appendix 81

4.4 | Product index, contact information 85

4.0

4.1

4.2

4.3

4.4

SIKO DriveLine: Shorter setup times, higher productivity!

“Short cycle times and changeover times, high productivity and quality with lower capital expenditure” is the recipe for success of ideal industrial processes.

The DriveLine actuators are particularly well suited for automatic format adjustment, stop positioning, tool alignment and valve adjustment as well as many other comparable positioning tasks: from a rotary actuator or actuator for simple applications and ancillary functions to a rotary drive and spindle drive or servo drive replacement for the control of complex machine processes and main processes, all of these tasks are easily mastered.

Thanks to a variety of sizes and forms, the integration of the actuator, the sensor and the control technology in a compact housing, different interfaces and bus systems, professional mechanical engineering is supported effectively in the integration and commissioning of the systems. The hollow shaft is mounted

by simply attaching and locking the drive shaft using a clamping ring (keyway is optional), also making flexible retrofitting of existing axes possible without the need for lengthy preparation for assembly and fastening with the corresponding couplings, adapters and covers.

Drives and actuators can be used in many production processes – both on individual machines or within whole production lines, for example in packaging technology, press technology, the wood, glass and printing industries, the plastics and textile industries as well as in tool construction and special machine construction.

Product change with parameters that vary substantially is an everyday occurrence and requires numerous adjustment procedures. In such cases, the exact reproducibility of each adjustment is just as important as performing tasks at difficult-to-access or dangerous positions. The flexibility in terms of changing production goods grows in line with increasing product quality.

Integration of the DriveLine actuators is simple, and the accelerating effect

as well as a lasting increase in machine efficiency and operational safety can be measured immediately. They are predestined for manufacturing chains where small batch sizes, frequent format changes or varying product sizes are daily business.

Benefit from the decentralized and modular automation with DriveLine and enhance your competitive edge: A wide range of versions and performance classes enables flexible scaling. Start and implement custom-made solutions – from the basic model up to high-end application.

More efficient axle adjustment: The true strength of DriveLine actuators lies in the useful series connection. When these modules are centrally controlled, they accomplish the adjustment work in only one cycle.



Drive Technology: New dynamics for production processes

The declared aim when designing modern processing machines and systems is to enhance the efficiency of machining processes while keeping costs down. Maximum productivity with minimum cycle times are key factors that have a considerable influence on the efficiency and profitability of a company. Flexible and modular axis automation with DriveLine actuators makes it easy to achieve a long-term increase in both the machine efficiency as well as the product quality. Adjustment with DriveLine actuators is around four times faster and much more accurate than with manual processes. Users speak of a boost in the production capacity of up to 50 percent.

These components are integrated into a very compact and modular design. They therefore set standards when it comes to size and performance:

- 24 V DC high-performance motor
- Spur gear / planetary gear with hollow output shaft
- Position encoder
- Power and control electronic units

These components are integrated into a very compact and modular design. They therefore set standards when it comes to size and performance. .

Benefits

- Flexible machine conception
- Very little installation and mounting effort
- Fast commissioning
- Short cycle or retrofitting time
- High productivity and quality
- High availability and maintenance-free

Versatile application

Automation with DriveLine actuators is suitable in any application if decentralized positioning tasks in the machine or the system are to be solved and space is at a minimum – without taking up any additional room in the control cabinet. Versatile retrofitting of existing axes is also possible without extending the control cabinet.

4.1

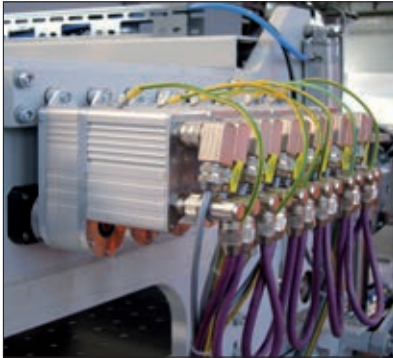

1

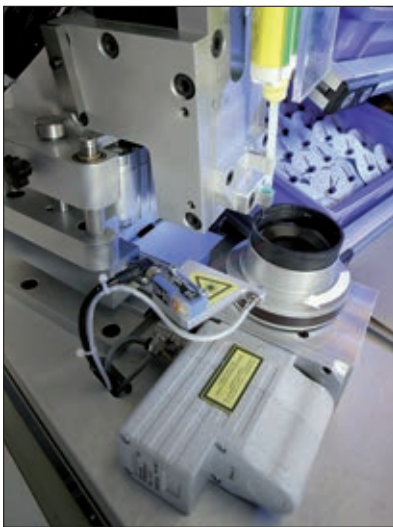

2

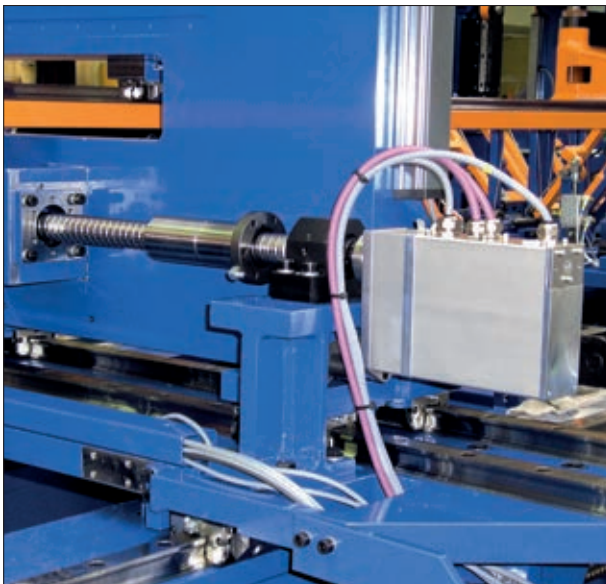

3

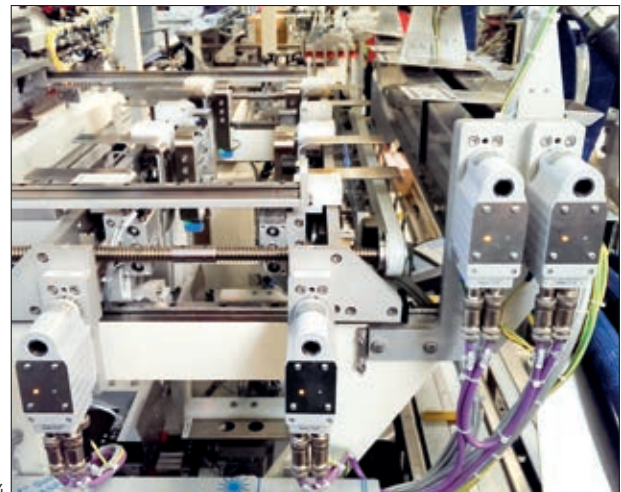

4



5

[1] DriveLine-actuators ensure precise product position on a panel feeding unit when on-the-fly production change is required. [2] Insert the part to be glued and press the start button: semi-automated gluing process with measurement feedback via a combination of magnetic ring and sensor (SIKO MagLine). [3] Power-pack: For applications with higher strength and safety requirements – precise setting position even in the de-energized state. [4] Many settings, quickly made: the benefits of decentralized modular automation of axes. [5] Spacing of guide rollers is regulated in a laser welding system for stainless steel pipes.

Performance charts

Key performance characteristics can be seen and compared in the following charts.

Measurement procedure

The performance chart of a DriveLine actuator shows the maximum performance curve (rpm/Nm) in relation to a particular motor/gear combination. All the characteristics refer to 24 V DC motors.

It can be seen that, performance data can deviate from the displayed values in actual use. This is due to a number of factors, such as motor-induced revolution divergences of $\pm 15\%$. We will be pleased to give you more detailed advice on these special cases.

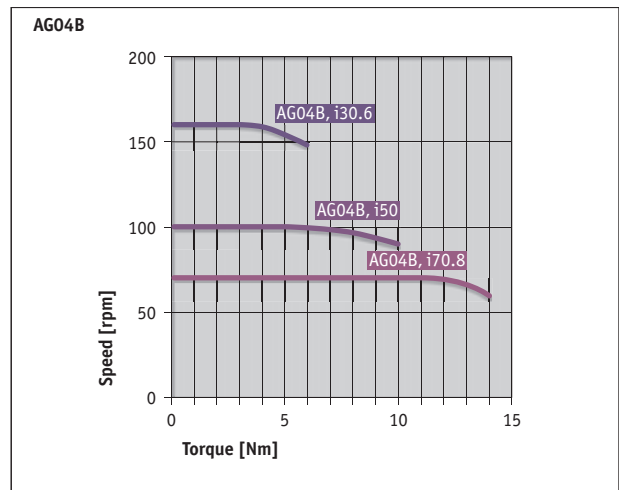
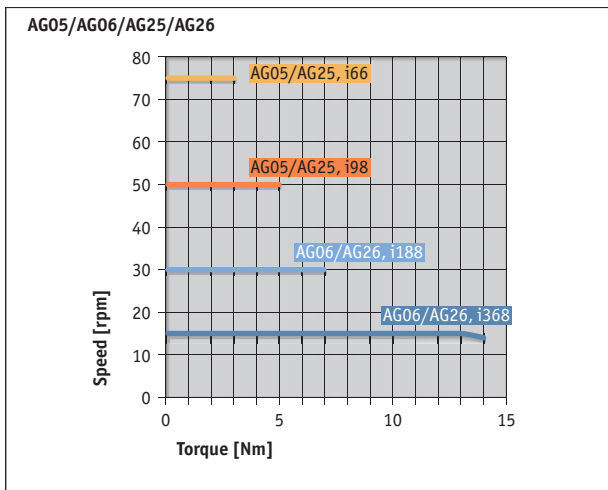
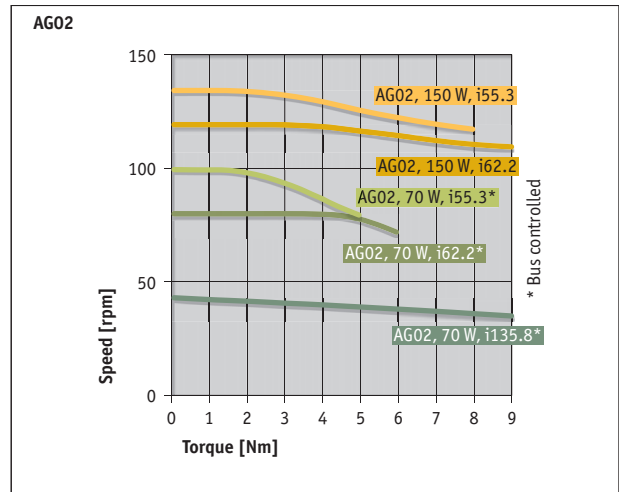
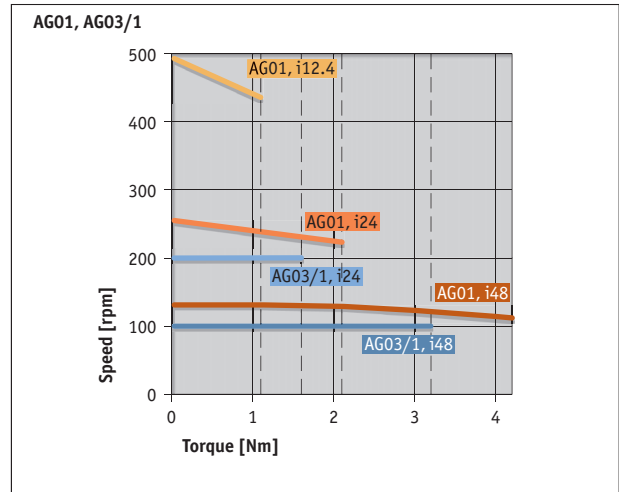

Torque support

The hollow shaft design of the DriveLine actuators is made for very simple mounting. A clamping ring on the device mounting side provides secure connection to the machine shaft.

The torque bracing to the machine frame is by means of a pin [1]. Alternatively, a mounting bracket can be used [2]. This type of securing enables use of an elastomere bushing [3], which provides a low-tension connection from the actuator to the machine shaft.

Advantage: The distortion forces on the bearing are reduced.

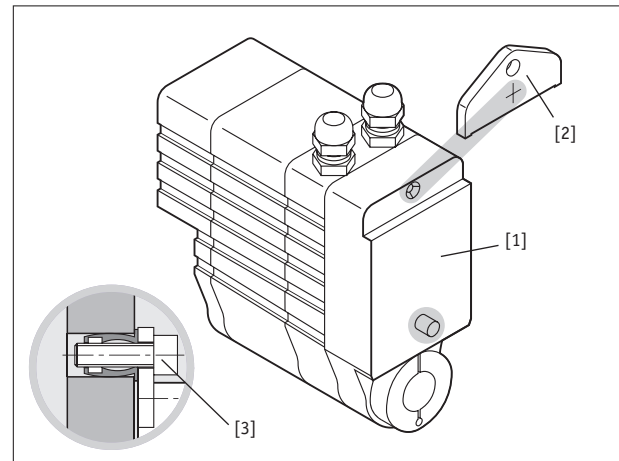

Mounting variants

The cleverly engineered design of the AG01 and AG03/1 opens up a host of installation variations. The tapered construction in the area of the hollow shaft makes small center-to-center distances of as little as 37 mm achievable.

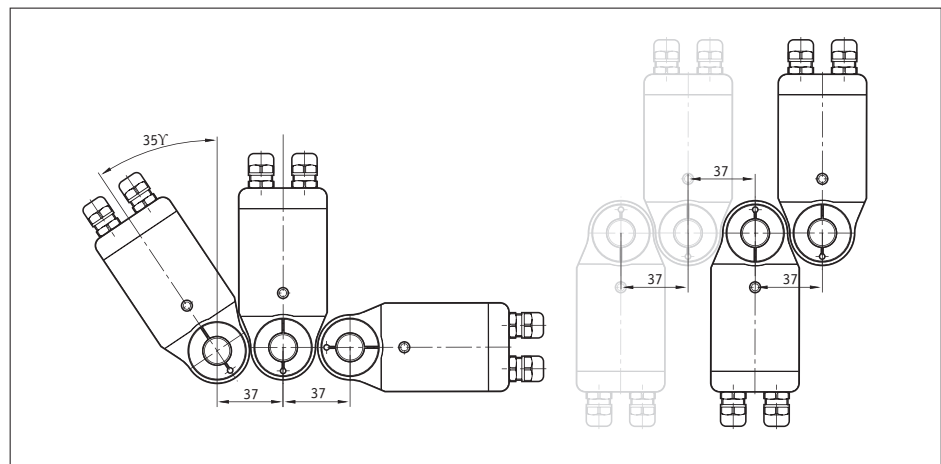

4.1

Compatible installations

Installation of the AG05, AG06, AG25 and AG26 actuators is compatible with DA09S and AP04 position indicators.

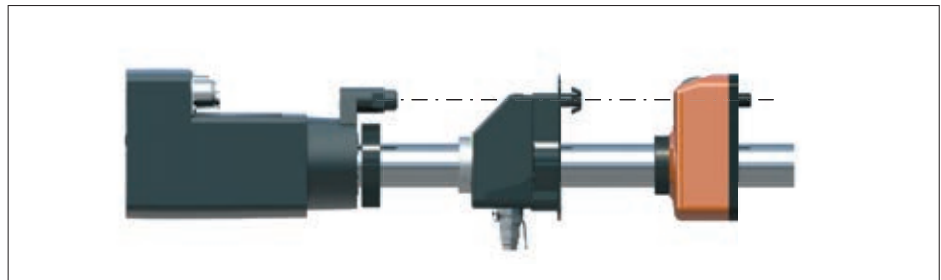

Output signals incremental

Note (AG01, AG02): The status of the signals A and B with regard to the reference signal 0/I is not defined and may deviate from this drawing.

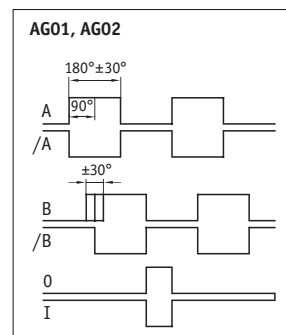

Ambient conditions

Examples of use



Direct adjustment:
Direct action via axle or spindle. The principle of action corresponds to that of a compound table or of linear guides.

Wood, metal and plastic processing

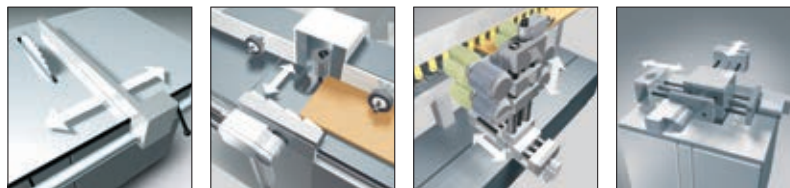

e.g., stop adjustment on saws and milling machines, tool settings according to the compound table principle ...

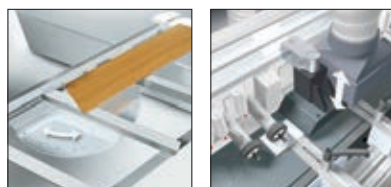

e.g., angle and position adjustment in the wood and metal industries ...



Indirect adjustment:
Indirect action (offset) on racks via cogwheel or worm gear.

Paper/converting



e.g., automated format, distance or throughput adjustment with spooling slitting machines (paper, foil), printing presses, filling machines ...









Rotating adjustment:
Direct action on the rotation axis or indirect action (offset) on a rotation axis via bevel gear or worm gear.

Logistics







e.g., adjustment of plants to rapidly changing tasks of conveyor belts ...

Actuators

							
	AG26 Fieldbus/IE	AG25 Fieldbus/IE	AG06 Fieldbus	AG05 Fieldbus	AG04B Fieldbus	AG03/1 Fieldbus	AG02 Fieldbus
Page	16	19	22	25	28	32	36
Speed/torque							
Rated torque max.	13 Nm	5 Nm	13 Nm	5 Nm	14 Nm	3.2 Nm	9 Nm
Rated speed max.	30 rpm	75 rpm	30 rpm	75 rpm	150 rpm	200 rpm	80 rpm
Driving shaft							
	20 mm hollow shaft	14 mm hollow shaft	20 mm hollow shaft	14 mm hollow shaft	20 mm hollow shaft	14 mm hollow shaft	14 mm hollow shaft
Outputs							
Absolute digital	•	•	•	•	•	•	•
Fieldbus (option)			CANopen SIKONETZ5	CANopen SIKONETZ5	Profibus DP	Profibus DP CANopen SIKONETZ5	Profibus DP CANopen
Industrial Ethernet	Ethernet/IP EtherCat POWERLINK PROFINET	Ethernet/IP EtherCat POWERLINK PROFINET					

4.1

Actuators

				
	AG02 Analog	AG02 Incremental	AG01 Analog	AG01 Incremental
Page	39	42	46	50
Speed/torque				
Rated torque max.	9 Nm	9 Nm	4.2 Nm	4.2 Nm
Rated speed max.	120 rpm	120 rpm	500 rpm	500 rpm
Driving shaft				
	14 mm hollow shaft	14 mm hollow shaft	14 mm hollow shaft	14 mm hollow shaft
Encoder				
Without		•		•
Potentiometric	•		•	
Current source 4 ... 20 mA	•		•	
Voltage 0 ... 10 V DC	•		•	
Incremental LD5		•		•
Incremental LD24		•		•
Incremental OP		•		•
Motor control				
Integrated		option		
External	option	option	option	option

Profile

- compact dimensions, high power density
- easy mounting and commissioning
- High flexibility, high protection category
- stainless steel 20 mm hollow shaft, robust housing
- Brushless EC motor with a long service life
- solid absolute sensor, magnetic sensing technology
- integrated power and control electronics
- Integrated Industrial-Ethernet-Fieldbus
- Integrated positioning controller
- M12 component mounting technology



4.1

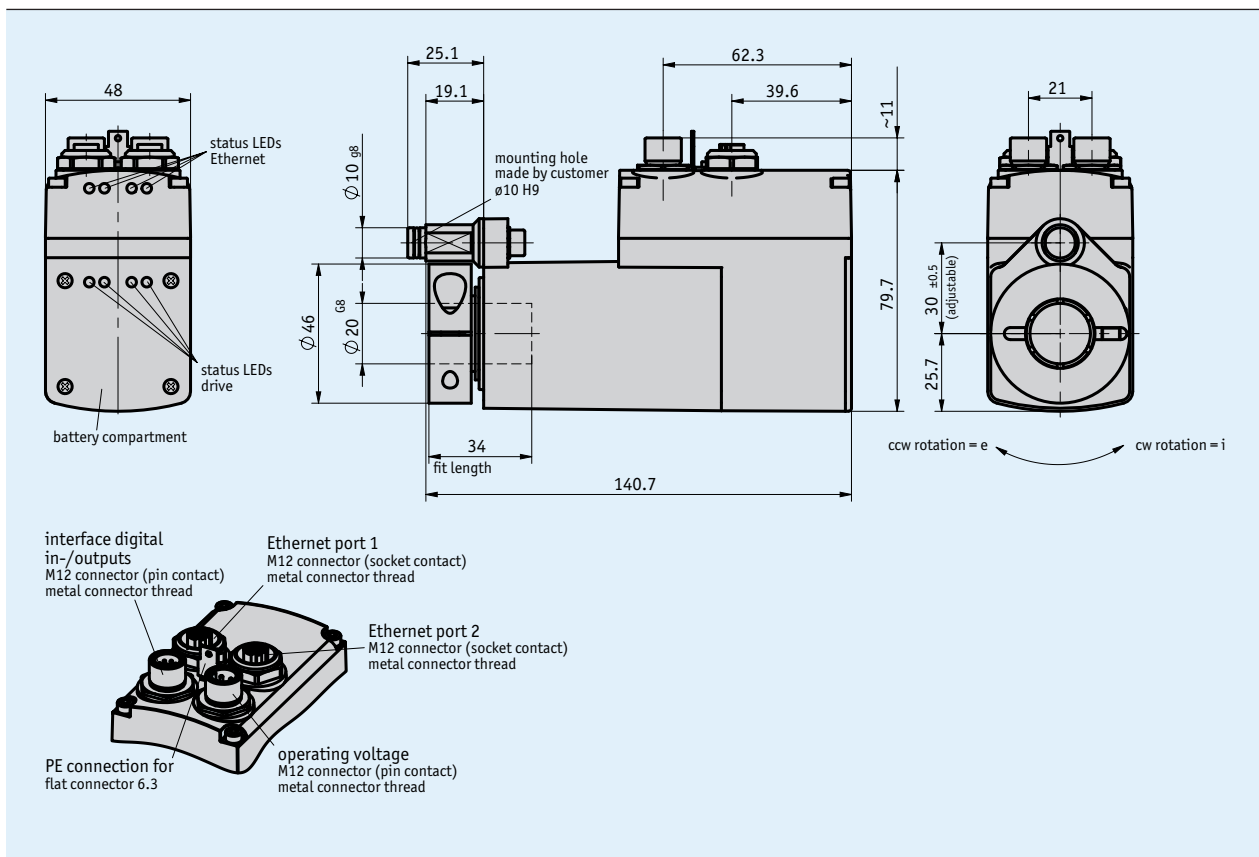

Mechanical data

Feature	Technical data	Additional information
Shaft	stainless steel	
Housing	glass-fiber reinforced plastic / zinc die-cast	
Clamping ring	stainless steel	
Torque pin	stainless steel	
Nominal torque/rated speed	7 Nm at 30 rpm ±10 % 13 Nm at 15 rpm ±10 %	i = 188 i = 368 (transiently adm. break-away torque 14 Nm)
Operating mode	intermittent duty S3: 25% DC, 10 min.	EN 60034-1

Electrical data

Feature	Technical data	Additional information
Operating voltage	24 V DC $\pm 10\%$	reverse polarity protected, output stage
	24 V DC $\pm 10\%$	reverse polarity protected, control
Current consumption	2.2 A $\pm 10\%$	at nominal torque/speed (output stage)
	<150 mA	starting current >150 mA (control)
Power input	≤ 58 W	output stage
	≤ 3.6 W	control
Battery	CR2477N, 3 V lithium, 950 mAh	
Battery service life	~5 year(s)	depending on ambient conditions
Digital inputs	17 ... 30 V DC	typically 10 mA
Status display	8 LEDs	
Keys	2 internal keys, internal DIP switch	
Switching outputs	24 V DC $\pm 10\%$	≤ 40 mA
Bus connection	EIP-EtherNet/IP	
	EPN-PROFINET	
	ECT-EtherCAT	
	EPL-POWERLINK	
Type of connection	2x M12 plug connectors (A-coded)	4-pole, 1x pin; 8-pole, 1x pin
	2x M12 plug connectors (D-coded)	4-pole, 2x socket
	grounding via flat connector 6.3 mm	

System data

Feature	Technical data	Additional information
Resolution	720 increments/revolution shaft	
Repeat accuracy	± 1 increment(s)	
Travel range	± 697 revolution(s)	i = 188
	± 356 revolution(s)	i = 368

Ambient conditions

Feature	Technical data	Additional information
Ambient temperature	0 ... 45 °C	
Storage temperature	-20 ... 60 °C	
Relative humidity		condensation inadmissible
EMC	EN 61800-3, second environment	interference resistance / immission
	EN 61800-3, C2	emitted interference / emission
Protection category	IP54, IP65	EN 60529, only with mating connector
Shock resistance	500 m/s ² , 11 ms	EN 60068-2-27
Vibration resistance	<100 m/s ² , 5 ... 150 Hz	EN 60068-2-6

Pin assignment

■ EtherCAT, EtherNet/IP, POWERLINK, PROFINET

Signal	PIN
Tx+	1
Rx+	2
Tx-	3
Rx-	4

■ Operating voltage (output stage / control)

Signal	PIN
+UB (output stage)	1
+UB (control)	2
GND (output stage)*	3
GND (control)*	4

* internally connected with SGND

■ Digital inputs / outputs

Signal	PIN
Input 1	1
Input 2	2
Input 3	3
Input 4	4
Output 1	5
RXD	6
TXD	7
SGND*	8

* internally connected with GND of operating voltage

Performance curve

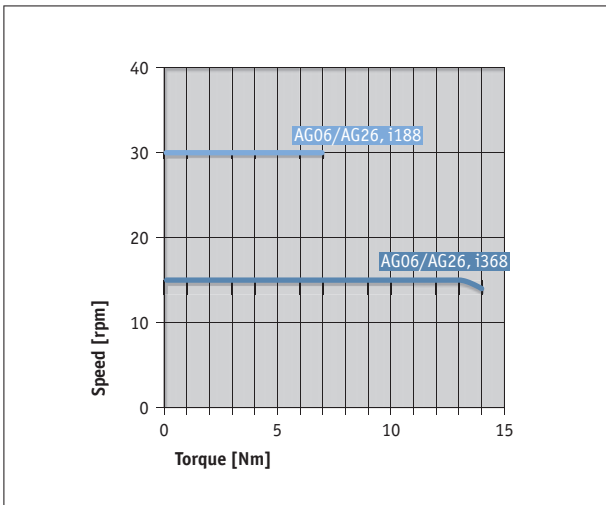

4.1

Order

Ordering table

Feature	Ordering data	Specification	Additional information
Gear ratio	188	i = 188	A
	368	i = 368	
Protection category	IP54	IP54	D
	IP65	IP65	
Interface/protocol	ECT	EtherCAT	C
	EIP	EtherNet/IP	
	EPL	POWERLINK	
	EPN	PROFINET	

Order key

AG26 Fieldbus/IE - A - 50W - B - KR/20 - B - ABM - C - SW

Scope of delivery: AG26 Fieldbus/IE, Documentation on CD, Mounting instructions

Accessories:

- Cable extension KV04S2 page 70
- Cable extension KV08S2 page 76
- Programming software ProTool DL www.siko-global.com
- Mating Connector Overview, overview page 58
- Mating connector, operating voltage, 4-pole, socket Order key 83526
- Mating connector, operating voltage, 4-pole, angle socket Order key 83091
- Mating connector, digital inputs/outputs, 8-pole, socket Order key 83525
- Mating connector, digital inputs/outputs, 8-pole, angle socket Order key 87599
- Mating connector, port 1 + port 2, 4-pole, pin Order key 87601
- Mating connector, port 1 + port 2, 4-pole, angular pin Order key 87600

Additional information:

General information and areas of application page 10

Profile

- Small dimensions, high power density
- easy mounting and commissioning
- High flexibility, high protection category
- stainless steel 14 mm diam. hollow shaft, robust housing
- Brushless EC motor with a long service life
- solid absolute sensor, magnetic sensing technology
- integrated power and control electronics
- Integrated Industrial-Ethernet-Fieldbus
- Integrated positioning controller
- M12 component mounting technology

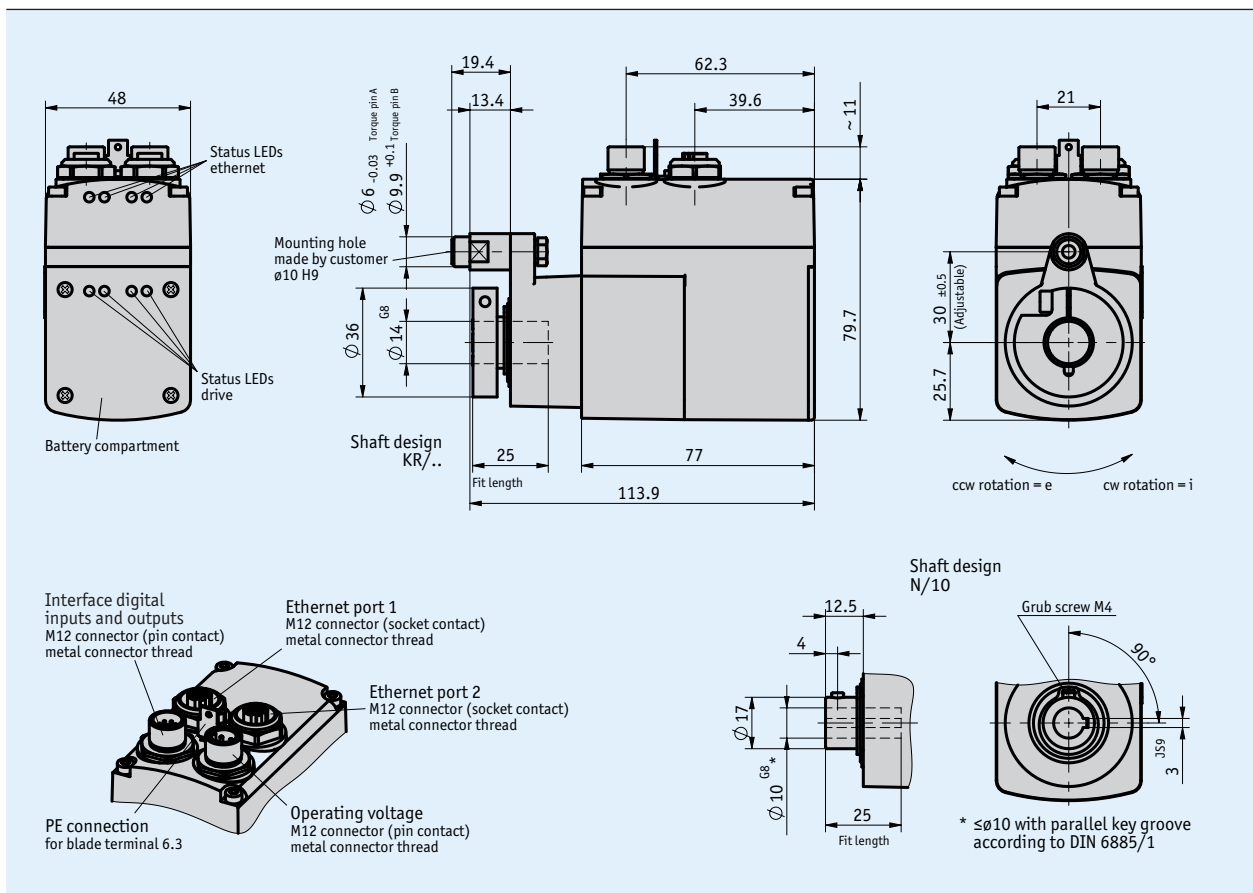

4.1

Mechanical data

Feature	Technical data	Additional information
Shaft	stainless steel	
Housing	glass-fiber reinforced plastic / zinc die-cast	
Clamping ring	stainless steel	
Torque pin	stainless steel	form A
	stainless steel	form B
Nominal torque/rated speed	5 Nm at 50 rpm ±10 %	i = 98
	3 Nm at 75 rpm ±10 %	i = 66
Operating mode	intermittent duty S3: 25% DC, 10 min.	EN 60034-1

Electrical data

Feature	Technical data	Additional information
Operating voltage	24 V DC $\pm 10\%$	reverse polarity protected, output stage
	24 V DC $\pm 10\%$	reverse polarity protected, control
Current consumption	2.2 A $\pm 10\%$	at nominal torque/speed (output stage)
	<150 mA	starting current >150 mA (control)
Power input	≤ 58 W	output stage
	≤ 3.6 W	control
Battery	CR2477N, 3 V lithium, 950 mAh	
Battery service life	~5 year(s)	depending on ambient conditions
Digital inputs	17 ... 30 V DC	typically 10 mA
Status display	8 LEDs	
Keys	2 internal keys, internal DIP switch	
Switching outputs	24 V DC $\pm 10\%$	≤ 40 mA
Bus connection	EIP-EtherNet/IP	
	EPN-PROFINET	
	ECT-EtherCAT	
	EPL-POWERLINK	
Type of connection	2x M12 plug connectors (A-coded)	4-pole, 1x pin; 8-pole, 1x pin
	2x M12 plug connectors (D-coded)	4-pole, 2x socket
	grounding via flat connector 6.3 mm	

4.1

System data

Feature	Technical data	Additional information
Resolution	720 increments/revolution shaft	
Repeat accuracy	± 1 increment(s)	
Travel range	± 1300 revolution(s)	i = 98
	± 1980 revolution(s)	i = 66

Ambient conditions

Feature	Technical data	Additional information
Ambient temperature	0 ... 45 °C	
Storage temperature	-20 ... 60 °C	
Relative humidity		condensation inadmissible
EMC	EN 61800-3, second environment	interference resistance / immission
	EN 61800-3, C2	emitted interference / emission
Protection category	IP54, IP65	EN 60529, only with mating connector
Shock resistance	500 m/s ² , 8 ms	EN 60068-2-27
Vibration resistance	<100 m/s ² , 5 ... 150 Hz	EN 60068-2-6

Pin assignment

■ EtherCAT, EtherNet/IP, POWERLINK, PROFINET

Signal	PIN
Tx+	1
Rx+	2
Tx-	3
Rx-	4

■ Operating voltage (output stage / control)

Signal	PIN
+UB (output stage)	1
+UB (control)	2
GND (output stage)*	3
GND (control)*	4

* internally connected with SGND

■ Digital inputs / outputs

Signal	PIN
Input 1	1
Input 2	2
Input 3	3
Input 4	4
Output 1	5
RXD	6
TXD	7
SGND*	8

* internally connected with GND of operating voltage

Performance curve

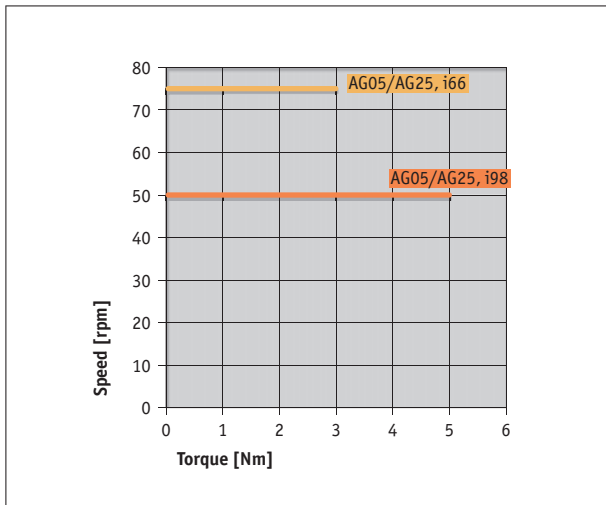

Order

Ordering table

Feature	Ordering data	Specification	Additional information
Gear ratio	66	i = 66	
	98	i = 98	
Protection category	IP54	IP54	
	IP65	IP65	
Shaft design/diameter	KR/14	clamping ring, ø14 mm	
	N/10	keyway, ø10 mm	
Torque pin	A	bolt, ø6 mm	
	B	bolt, ø10 mm	Aluminum
Interface/protocol	ECT	EtherCAT	
	EIP	EtherNet/IP	
	EPL	POWERLINK	
	EPN	PROFINET	

Order key

AG25 Fieldbus/IE - A - 50W - B - C - D - ABM - E - SW

Scope of delivery: AG25 Fieldbus/IE, Mounting instructions, Documentation on CD

Accessories:

angular gear WG05

Cable extension KV04S2

Cable extension KV08S2

Programming software ProTool DL

Mating Connector Overview, overview

Mating connector, operating voltage, 4-pole, socket

Mating connector, operating voltage, 4-pole, angle socket

Mating connector, digital inputs/outputs, 8-pole, socket

Mating connector, digital inputs/outputs, 8-pole, angle socket

Mating connector, port 1 + port 2, 4-pole, pin

Mating connector, port 1 + port 2, 4-pole, angular pin

Additional information:

General information and areas of application

www.siko-global.com

page 70

page 76

www.siko-global.com

page 58

Order key 83526

Order key 83091

Order key 83525

Order key 87599

Order key 87601

Order key 87600

page 10

Profile

- easy mounting, no additional coupling needed
- stainless steel hollow shaft, glass fibre reinforced casing
- brushless 24 VDC motor with long service life
- solid absolute sensor, magnetic sensing technology
- 2-line LCD for target and position value and operating keys
- 2 LEDs for user guidance
- integrated RS485 or CANopen interface
- Integrated positioning controller
- M8 + M12 component mounting technology

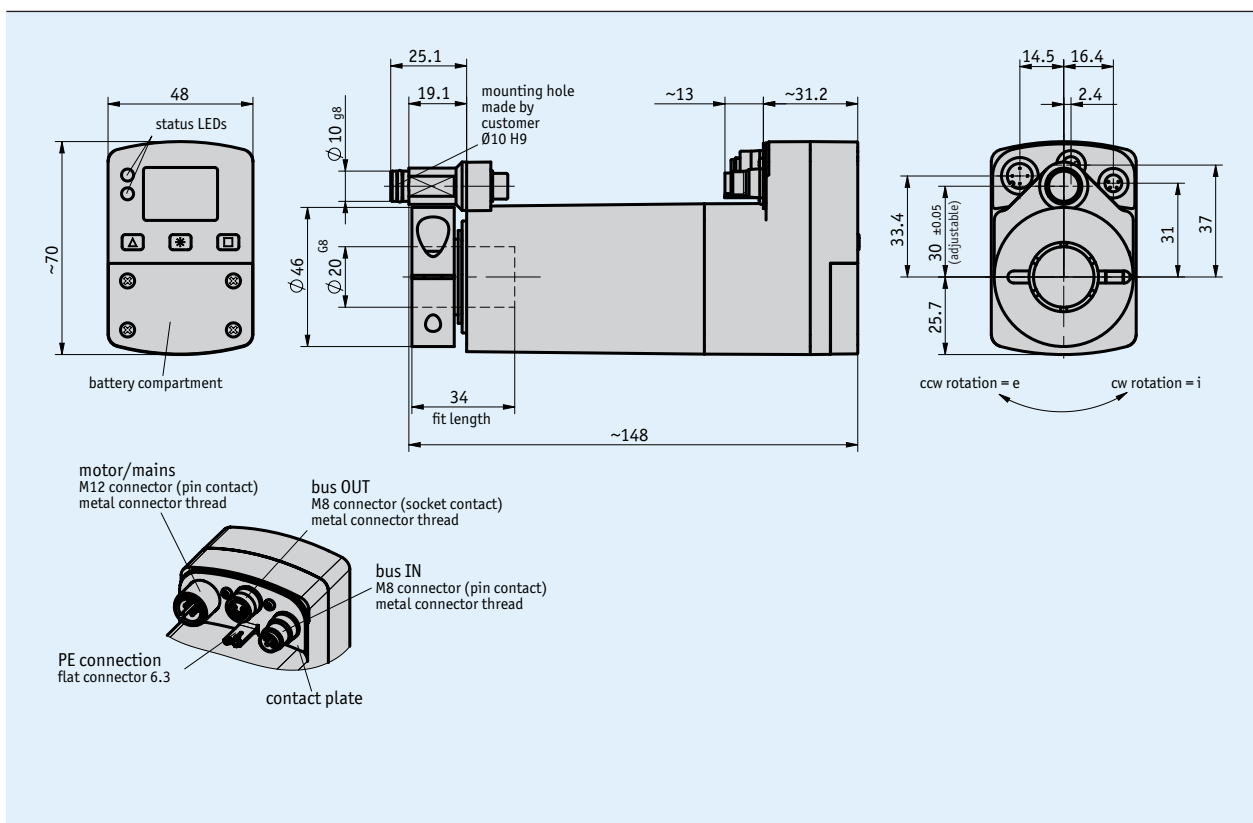

Mechanical data

Feature	Technical data	Additional information
Shaft	stainless steel	
Housing	glass-fiber reinforced plastic	
Clamping ring	stainless steel	
Torque pin	stainless steel	
Nominal torque/rated speed	7 Nm at 30 rpm $\pm 10\%$ 13 Nm at 15 rpm $\pm 10\%$	i = 188 i = 368 (14 Nm temporarily adm. break-away torque)
Operating mode	S3 intermittent duty: 25 % DC, 10 min.	EN 60034-1
Weight	~0.9 kg	

Electrical data

Feature	Technical data	Additional information
Operating voltage	24 V DC $\pm 10\%$	reverse polarity protected, output stage
	24 V DC $\pm 10\%$	reverse polarity protected, control
Current consumption	2.42 A	max. adm. at set point 100% (output stage)
Power input	~48 W	output stage
Battery	CR2477N, 3 V lithium, 950 mAh	
Battery service life	~5 year(s)	depending on environmental conditions
Rated current	2.2 A $\pm 10\%$	at max. adm. torque (output stage)
	<60 mA	at 24 V DC (control)
Display/display range	5-digit LCD 7-segment, ~7 mm height	decimal points, 2 rows, special characters
Special character	battery, direction arrows	
Status display	two LEDs	
Keys	parameterizing, resetting, inching, setpoint definition	
Bus connection	RS485; CANopen	no galvanic isolation
Type of connection	1x M12-plug connector (A-coded)	4-pole, 1x pin
	2x M8 plug connectors	4-pole, 1x socket, 1x pin
	grounding via flat connector 6.3 mm	

System data

Feature	Technical data	Additional information
Resolution	720 increments/revolution shaft	
Repeat accuracy	± 1 increment(s)	
Travel range	± 697 revolution(s)	i = 188
	± 356 revolution(s)	i = 368

4.1

Ambient conditions

Feature	Technical data	Additional information
Ambient temperature	0 ... 45 °C	
Storage temperature	-20 ... 60 °C	
Relative humidity		condensation inadmissible
EMC	EN 61800-3, second environment	interference resistance / immission
	EN 61800-3, C3	emitted interference / emission
Protection category	IP54, IP65	EN 60529, mating connectors mounted
Shock resistance	500 m/s ² , 11 ms	EN 60068-2-27
Vibration resistance	<100 m/s ² , 5 ... 150 Hz	EN 60068-2-6

Pin assignment

■ Operating voltage (A-coded)

Signal	PIN
+24 V Output stage	1
+24 V Control	2
GND Output stage*	3
GND Control*	4

■ Interfaces M8

Signal	PIN
DÜB/TxRX-/CANL	1
DÜA/TxRX+/CANH	2
Do not connect!	3
SGND*	4

* internally linked

Performance curve

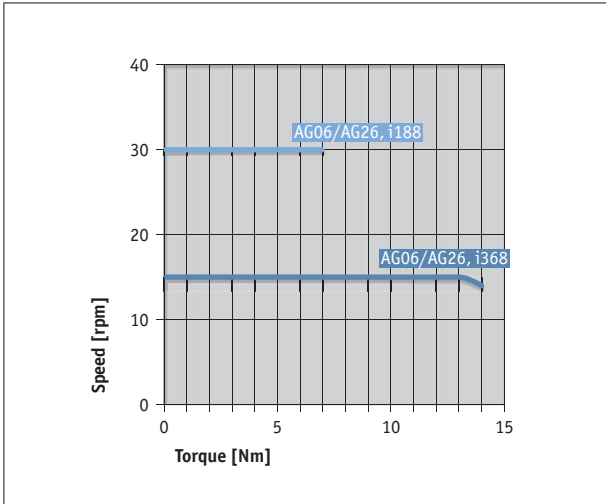

4.1

Order

Ordering table

Feature	Ordering data	Specification	Additional information
Gear ratio	188	i = 188	
	368	i = 368	
Protection category	IP54	IP54	
	IP65	IP65	
Shaft design/diameter	KR/20	clamping ring, ø20 mm others on request	
Interface/protocol	S3/09	RS485/SIKONETZ5	
	CAN	CANopen	

Order key

AG06 Fieldbus - A - 50W - B - C - B - ABM - D - SW

Scope of delivery: AG06 Fieldbus, Mounting instructions, Documentation on CD

Accessories:

- Cable extension KV04S1 page 68
- Cable extension KV04S2 page 70
- Easy Touch Control ETC5000 www.siko-global.com
- Programming software ProTool DL www.siko-global.com
- Mating Connector Overview page 58
- Mating connector, Fieldbus IN, 4-pole, socket Order key 84209
- Mating connector, Fieldbus OUT, 4-pole, pin Order key 84210
- Mating connector, voltage supply, 4-pole, angle socket Order key 83091
- Bus terminating connector, Fieldbus, 4-pole, pin Order key BAS-0005

Additional information:

General information and areas of application page 10

Profile

- easy mounting, no additional coupling needed
- stainless steel 14 mm hollow shaft, glass fibre reinforced casing
- brushless 24 VDC motor with long service life
- solid absolute sensor, magnetic sensing technology
- 2-line LCD for target and position value and operating keys
- 2 LEDs for user guidance
- integrated RS485 or CANopen interface
- Integrated positioning controller
- M8 + M12 component mounting technology

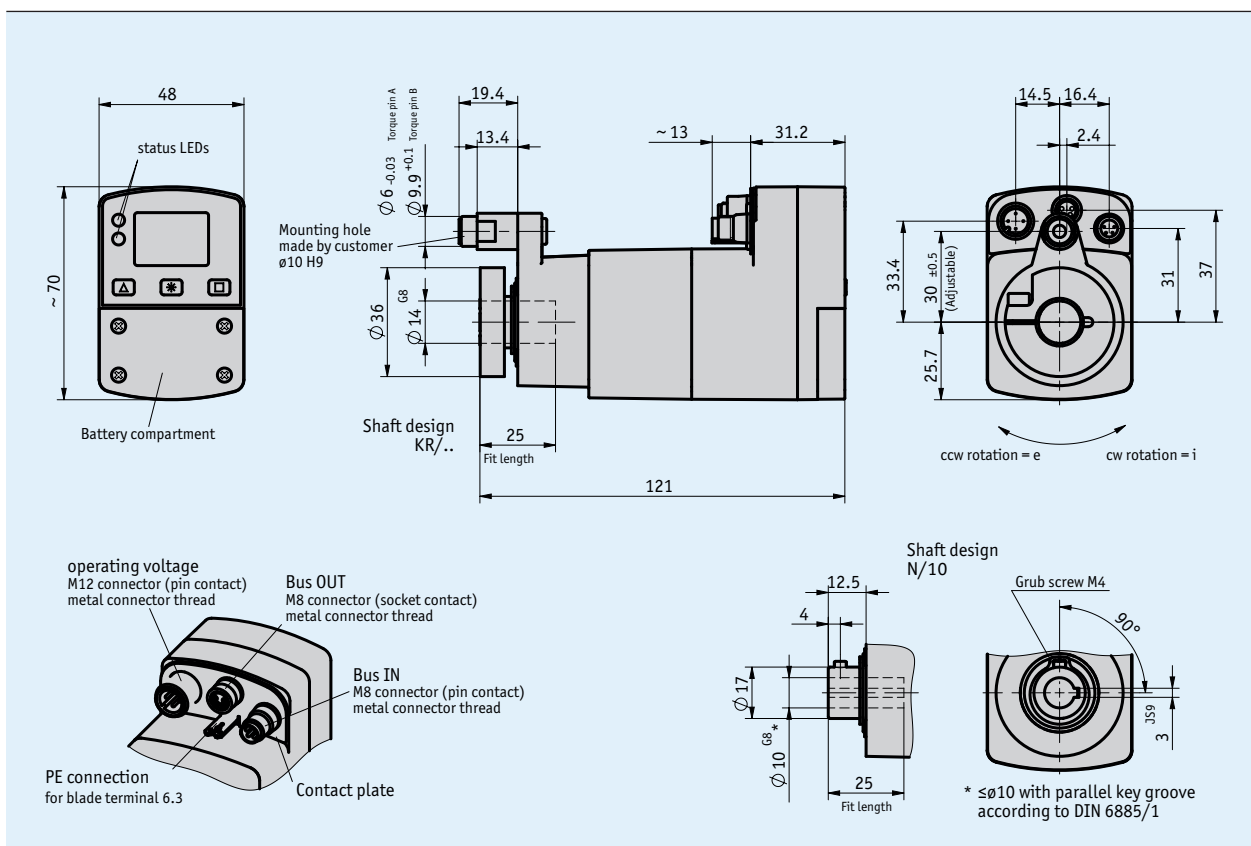

4.1

Mechanical data

Feature	Technical data	Additional information
Shaft	stainless steel	
Housing	glass-fiber reinforced plastic	
Clamping ring	stainless steel	
Torque pin	stainless steel	form A
	stainless steel	form B
Nominal torque/rated speed	3 Nm at 75 rpm ± 10 %	i = 66
	5 Nm at 50 rpm ± 10 %	i = 98
Weight	~ 0.45 kg	

Electrical data

Feature	Technical data	Additional information
Operating voltage	24 V DC $\pm 10\%$	reverse polarity protected, output stage
	24 V DC $\pm 10\%$	reverse polarity protected, control
Power input	~58 W	output stage
Battery	CR2477N, 3 V lithium, 950 mAh	
Battery service life	~5 year(s)	depending on ambient conditions
Rated current	2.2 A $\pm 10\%$	at max. admissible torque (output stage)
	<60 mA $\pm 10\%$	at 24 V DC (control)
Display/display range	5-digit LCD 7-segment, ~7 mm height	decimal points, 2 rows, special characters
Special character	battery, direction arrows	
Status display	two LEDs	
Keys	parameterizing, resetting, inching, setpoint definition	
Bus connection	RS485, CANopen	no galvanic isolation
Type of connection	1x M12 plug connector (A-coded)	4-pole, 1x pin
	2x M8 plug connectors	4-pole, 1x socket, 1x pin
	grounding via flat connector 6.3 mm	

System data

Feature	Technical data	Additional information
Resolution	720 increments/revolution shaft	
Repeat accuracy	± 1 increment(s)	
Travel range	± 1980 revolution(s)	i = 66
	± 1300 revolution(s)	i = 98

Ambient conditions

Feature	Technical data	Additional information
Ambient temperature	0 ... 45 °C	
Storage temperature	-20 ... 60 °C	
Relative humidity		condensation inadmissible
EMC	EN 61800-3, second environment	interference resistance / immission
	EN 61800-3, C3	emitted interference / emission
Protection category	IP54, IP65	EN 60529, only with mating connector
Shock resistance	500 m/s ² , 8 ms	EN 60068-2-27
Vibration resistance	<100 m/s ² , 5 ... 150 Hz	EN 60068-2-6

Pin assignment

■ Operating voltage M12 (A-coded)

Signal	PIN
+24 V Power/output stage	1
+24 V Control	2
GND Power/output stage	3
GND Control	4

■ Interfaces M8

Signal	PIN
TxRx-/DÜB	1
TxRx+/DÜA	2
N.C.	3
GND	4

Performance curve

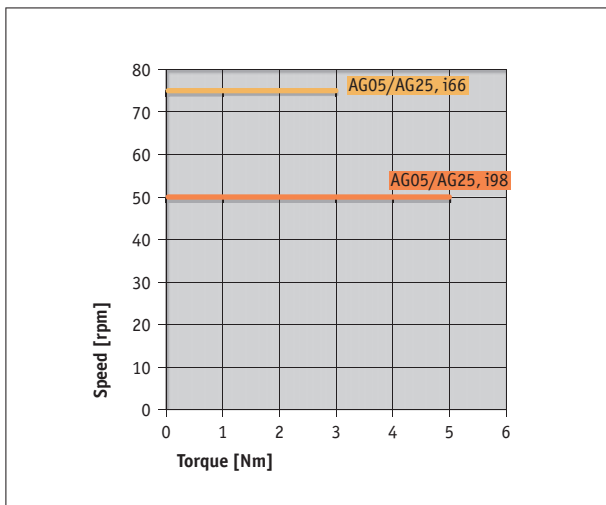

Order

Ordering table

Feature	Ordering data	Specification	Additional information
Gear ratio	66	i = 66	
	98	i = 98	
Protection category	IP54	IP54	
	IP65	IP65 on request	
Shaft design/diameter	KR/14	clamping ring ø14 mm	
	N/10	keyway, ø10 mm	
Torque pin	A	bolt, ø6 mm	
	B	bolt, ø10 mm	
Interface/protocol	S3/09	RS485 / SIKONETZ5	
	CAN	CANopen	

Order key

AG05 Fieldbus - - 50W - - - - ABM -

Scope of delivery: AG05 Fieldbus, Mounting instructions, Documentation on CD

Accessories:

angular gear WG05	www.siko-global.com
Cable extension KV04S1	page 68
Cable extension KV04S2	page 70
Easy Touch Control ETC5000	www.siko-global.com
Programming software ProTool DL	www.siko-global.com
Mating Connector Overview	page 58
Mating connector, Fieldbus IN, 4-pole, socket	Order key 84209
Mating connector, Fieldbus OUT, 4-pole, pin	Order key 84210
Mating connector, operating voltage, 4-pole, angle socket	Order key 83091
Bus terminating connector, Fieldbus, 4-pole, pin	Order key BAS-0005

Additional information:

General information and areas of application page 10

Profile

- Easy mounting
- Stainless steel hollow shafts up to max. \varnothing 20 mm
- "Manual" traveling without control via micro-button
- Brushless 160 W, 24 V DC motor with long service life
- Integrated absolute position encoder on the output shaft
- Electrical connection via spring terminals or connector
- Integrated positioning controller
- Integrated fieldbus interface
- Integrated spring-operated brake (option)



4.1

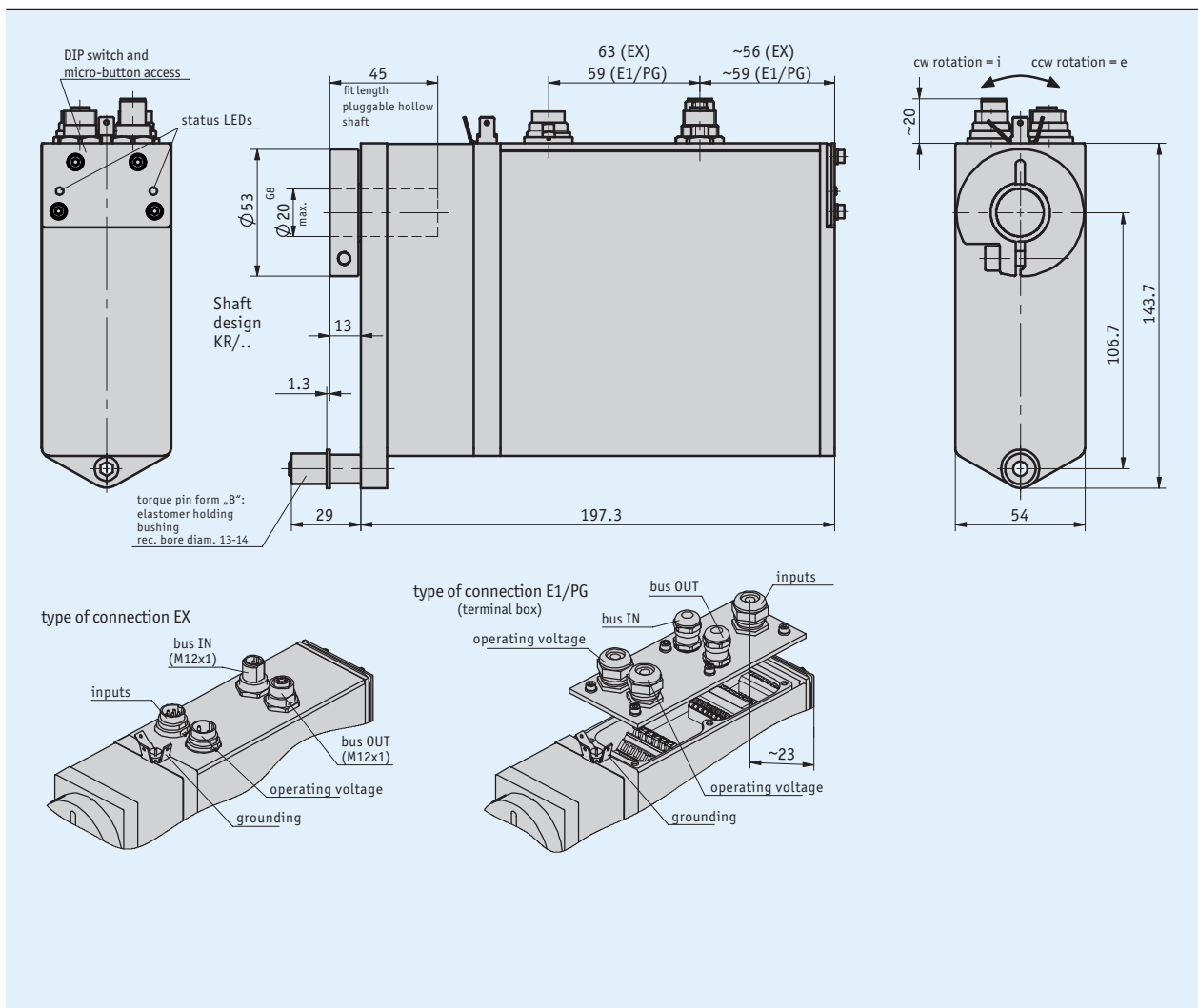

Mechanical data

Feature	Technical data	Additional information
Shaft	stainless steel	
Housing	aluminum	
Nominal torque/rated speed	6 Nm at 150 rpm ($\pm 10\%$)	i = 30.6 (max. adm. operating point)
	10 Nm at 90 rpm ($\pm 10\%$)	i = 50 (max. adm. operating point)
	14 Nm at 64 rpm ($\pm 10\%$)	i = 70.8 (max. adm. operating point)
Operating mode	S3 intermittent duty: 25 % DC, 10 min.	EN 60034-1
Weight	~3.2 kg	

Electrical data

Feature	Technical data	Additional information
Operating voltage	24 V DC $\pm 10\%$	reverse polarity protected
Power input	~160 W	
Rated current	6 A $\pm 5\%$	
No-load current	350 mA $\pm 20\%$	(with transmission)
Type of connection	5x PG9, terminal strip	0.13 ... 2.5 mm ² or 0.25 ... 1.5 mm ² (E1/PG)
	2x M16 plug connectors	3-pole, 1x pin; 7-pole, 1x pin (EX)
	2x M12 plug connectors (B-coded)	5-pole, 1x pin, 1x socket (EX)
	grounding via flat connector 6.3 mm	

4.1

System data

Feature	Technical data	Additional information
Resolution	1024 increment(s)	singleturn / 10 bit
Travel range	254 revolution(s)	8 bit multiturn (rounded)
	4094 revolution(s)	12 bit multiturn (rounded)

Ambient conditions

Feature	Technical data	Additional information
Ambient temperature	0 ... 45 °C	
Storage temperature	-20 ... 80 °C	
Relative humidity		condensation inadmissible
EMC	EN 61800-3, second environment	interference resistance / immission
	EN 61800-3, C3	emitted interference / emission
Protection category	IP50 / IP54 / IP65	EN 60529, mating connectors mounted
Shock resistance	500 m/s ² , 11 ms	EN 60068-2-27
Vibration resistance	100 m/s ² , 50 Hz	EN 60068-2-6

Pin assignment

■ Operating voltage

Signal	EX	E1 (terminal)
+Ub	1	X1.1 X1.2
Enable	2	X3.5
GND	3	X1.3 X1.4
Screen		X1.5 X1.6

■ Fieldbus

Signal	EX	E1 (terminal)
BUS A	2	X2.2, X2.9
BUS B	4	X2.1, X2.10
Do not connect!	1, 3, 5	X2.3, X2.4, X2.5, X2.6, X2.7, X2.8

■ Inputs

Signal	EX	E1 (terminal)
Limit switch 1	1	X3.1
Limit switch 2	2	X3.2
Input 1	3	X3.3
Input 2	4	X3.4
N.C.	5-7	
Enable		X3.5
EXT_GND		X3.6
GND		X3.7

Performance curve

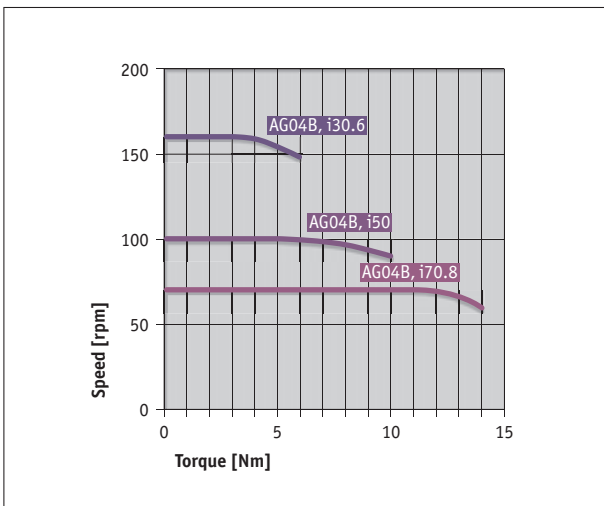

4.1

Order

Ordering table

Feature	Ordering data	Specification	Additional information
Gear ratio	70.8	i = 70.8	
	50	i = 50.0	
	30.6	i = 30.6	
		others on request	
Motor/brake	160W/MB	160 W EC motor with brake	
	160W/OB	160 W EC motor without brake	
Protection category	IP50	IP50	
	IP54	IP54	
	IP65	IP65	
Shaft design/diameter	KR/20	clamping ring ø20 mm	
	KR/14	clamping ring ø14 mm	
		others on request	
Type of connection	EX	industrial connector	without mains outlet
	E1/PG	terminal box	with mains outlet
Number of revolutions	254	8 Bit (rounded)	254 revolutions
	4094	12 Bit (rounded)	4094 revolutions

4.1

Order key

AG04B Fieldbus - A - B - C - D - B - E - F - PB - SW

Scope of delivery: AG04B Fieldbus, Mounting instructions, Documentation on CD

Accessories:

Cable extension KV03S1	page 64
Cable extension KV07S0	page 72
Programming software ProTool DL	www.siko-global.com
Mating Connector Overview	page 58
Mating connector, encoder/digital inputs, 7-pole, socket	Order key 76141
Mating connector, encoder/digital inputs, 7-pole, angle socket	Order key 78088
Mating connector, operating voltage, 3-pole, socket	Order key 85057
Mating connector, operating voltage, 3-pole, socket	Order key 85057
Mating connector, Profibus IN, 5-pole, socket	Order key 83991
Mating connector, Profibus IN, 5-pole, angle socket	Order key 82804
Mating connector, Profibus OUT, 5-pole, pin	Order key 83992
Mating connector, Profibus OUT, 5-pole, angular pin	Order key 82805

Additional information:

General information and areas of application page 10

Profile

- Space-saving, easy mounting
- Through hollow shafts up to max. $\varnothing 14$ mm
- Brushless 50 W, 24 V EC motor with long service life
- Integrated power and control electronics with inverse polarity and overload protection
- Integrated absolute position encoder on the output shaft
- Integrated CANopen or Profibus-DP with M12 component mounting technology
- Integrated RS458/SIKONETZ5 interface with M8 component mounting technology



4.1

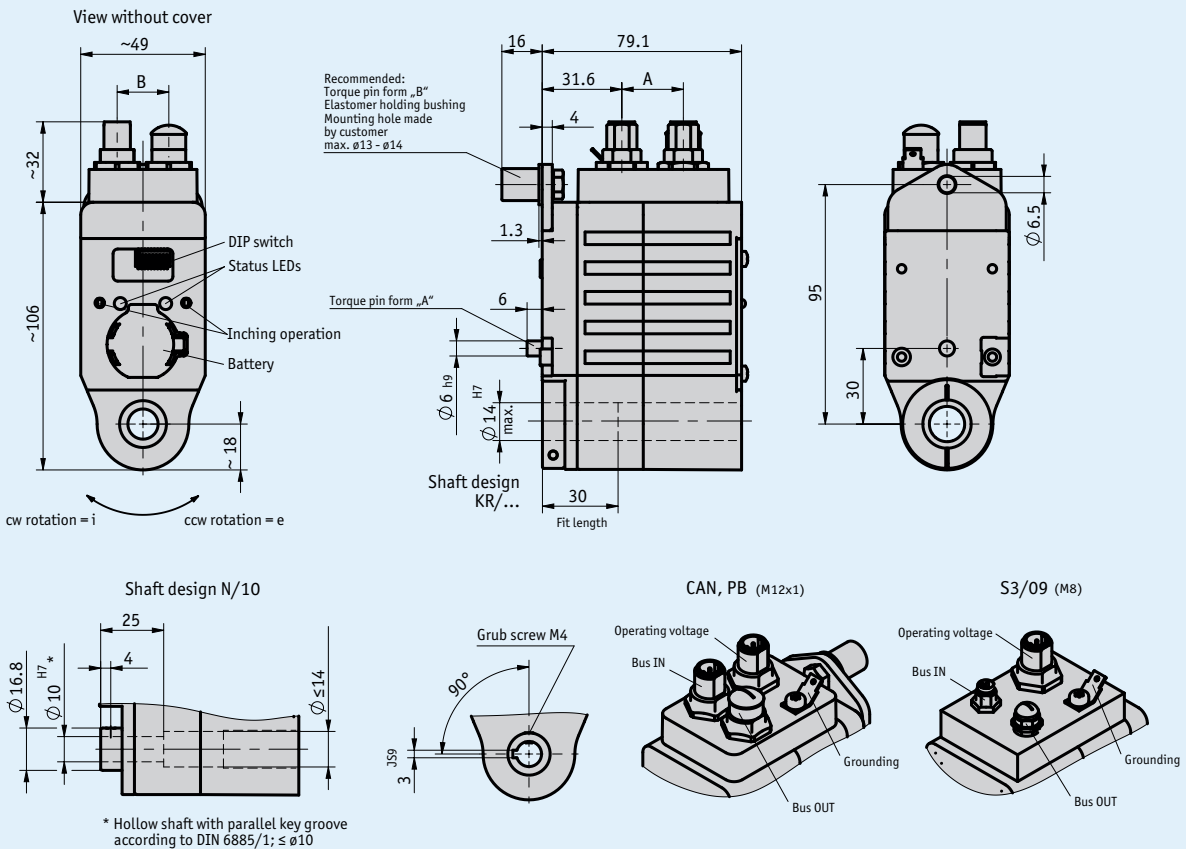

	Measure "A"	Measure "B"
S3/09	27.2	23.0
CAN, PB	24.4	20.5

Mechanical data

Feature	Technical data	Additional information
Shaft	black-finished steel	
Housing	aluminum/zinc die cast	anodized / powder-coated
Nominal torque/rated speed	3.2 Nm at 100 rpm	i = 48
	1.6 Nm at 200 rpm	i = 24
Operating mode	S3 intermittent operation: 25 % DC, 10 min.	EN 60034-1

Electrical data

Feature	Technical data	Additional information
Operating voltage	24 V DC $\pm 10\%$	reverse polarity protected, output stage
	24 V DC $\pm 10\%$	reverse polarity protected, control (only CAN, PB, S3/09)
Power input	58 W	output stage
Battery	CR2477N, 3 V lithium, 950 mAh	
Battery service life	~5 year(s)	depending on ambient conditions
Rated current	2.4 A $\pm 10\%$	at max. adm. torque (output stage)
	<100 mA	at 24 V DC (control), only CAN, PB, S3/09
Status display	two LEDs	
Keys	touch keys	for setting-up mode
Bus connection	CANopen, Profibus-DP, SIKONETZ5	galvanic isolation
	Profibus-DP	galvanic isolation
	SIKONETZ5	galvanic isolation
Type of connection	2x M12-plug connectors (A-coded)	5-pole, 1x socket, 1x pin (CAN)
	2x M12 plug connectors (B-coded)	5-pole, 1x socket, 1x pin (PB)
	2x M8-plug connectors	4-pole, 1 x socket, 1 x pin (S3/09)
	1x M12-plug connector (A-coded)	4-pole, 1x pin (CAN + PB + S3/09)
	grounding via flat connector 6.3 mm	

4.1

System data

Feature	Technical data	Additional information
Resolution	1600 increments/revolution	
System accuracy	$\pm 0.8^\circ$	unidirectional
Repeat accuracy	± 1 increment(s)	unidirectional / bidirectional
Travel range	± 8192 revolution(s)	

Ambient conditions

Feature	Technical data	Additional information
Ambient temperature	0 ... 45 °C	
Storage temperature	-20 ... 60 °C	
Relative humidity		condensation inadmissible
EMC	EN 61800-3, second environment	interference resistance / immission
	EN 61800-3, C3	emitted interference / emission
Protection category	IP50 / IP54 / IP65	EN 60529, mating connectors mounted
Shock resistance	500 m/s ² , 8 ms	EN 60068-2-27
Vibration resistance	≤ 100 m/s ² , 5 ... 150 Hz	EN 60068-2-6

Pin assignment

■ Operating voltage

CAN, PB, S3/09	PIN
+UB (output stage)	1
+UB (control)	2
GND (output stage + control)	3
N.C.	4

■ Fieldbus S3/09

Signal	PIN
DÜB/TxRx-	1
DÜA/TxRx+	2
N.C.	3
SGND	4

■ Fieldbus PB, CAN

PB	CAN	PIN
N.C.	N.C.	1
BUS A	N.C.	2
N.C.	CAN_GND	3
BUS B	CAN_H	4
N.C.	CAN_L	5

Performance curve

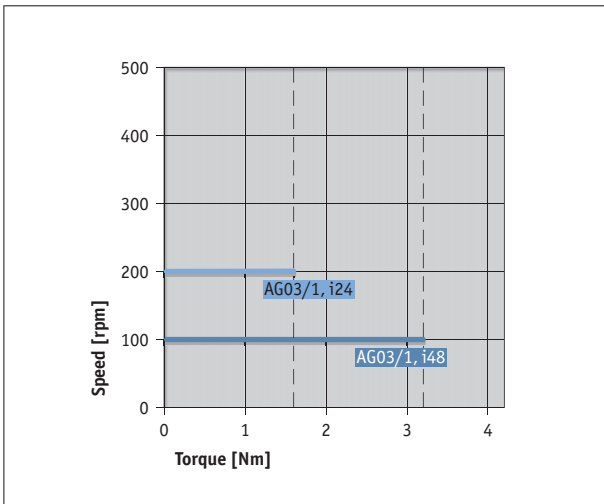

4.1

Order

Ordering table

Feature	Ordering data	Specification	Additional information
Gear ratio	48	i = 48	
	24	i = 24	
Protection category	IP50	IP50	
	IP54	IP54	
	IP65	IP65	
Shaft design/diameter	KR/14	clamping ring ø14 mm	
	KR/12	clamping ring ø12 mm	
	N/10	keyway JS9 DIN 6885/1 ø10 mm	
Torque pin	A	bolt, ø6 mm	
	B	lug I	
Fieldbus	CAN	CANopen	
	PB	Profibus-DP	Profidrive
	S3/09	RS485 / SIKONETZ5	

Order key

AG03/1 Fieldbus - A - B - C - D - ABM - E - SW

4.1

Scope of delivery: AG03/1 Fieldbus, Mounting instructions, Documentation on CD

Accessories:

Cable extension KV04S1	page 68
Cable extension KV04S2	page 70
Easy Touch Control ETC5000	www.siko-global.com
Programming software ProTool DL	www.siko-global.com
Mating Connector Overview	page 58
Mating connector, operating voltage, 4-pole, socket	Order key 83526
Mating connector, operating voltage, 4-pole, angle socket	Order key 83091
Mating connector, Profibus IN, 5-pole, angle socket	Order key 82804
Mating connector, Profibus IN, 5-pole, socket	Order key 83991
Mating connector, Profibus OUT, 5-pole, angular pin	Order key 82805
Mating connector, Profibus OUT, 5-pole, pin	Order key 83992
Mating connector, CANopen IN, 5-pole, angle socket	Order key 83006
Mating connector, CANopen IN, 5-pole, socket	Order key 84109
Mating connector, CANopen OUT, 5-pole, angular pin	Order key 83007
Mating connector, CANopen OUT, 5-pole, pin	Order key 84732
Mating connector, bus IN, 4-pole, socket	Order key 84209
Mating connector, bus OUT, 4-pole, pin	Order key 84210

Additional information:

General information and areas of application page 10

Profile

- Easy mounting
- Through hollow shafts up to max. $\varnothing 14$ mm
- Integrated absolute position encoder on the output shaft
- Integrated positioning controller
- Integrated fieldbus interface (option)



4.1

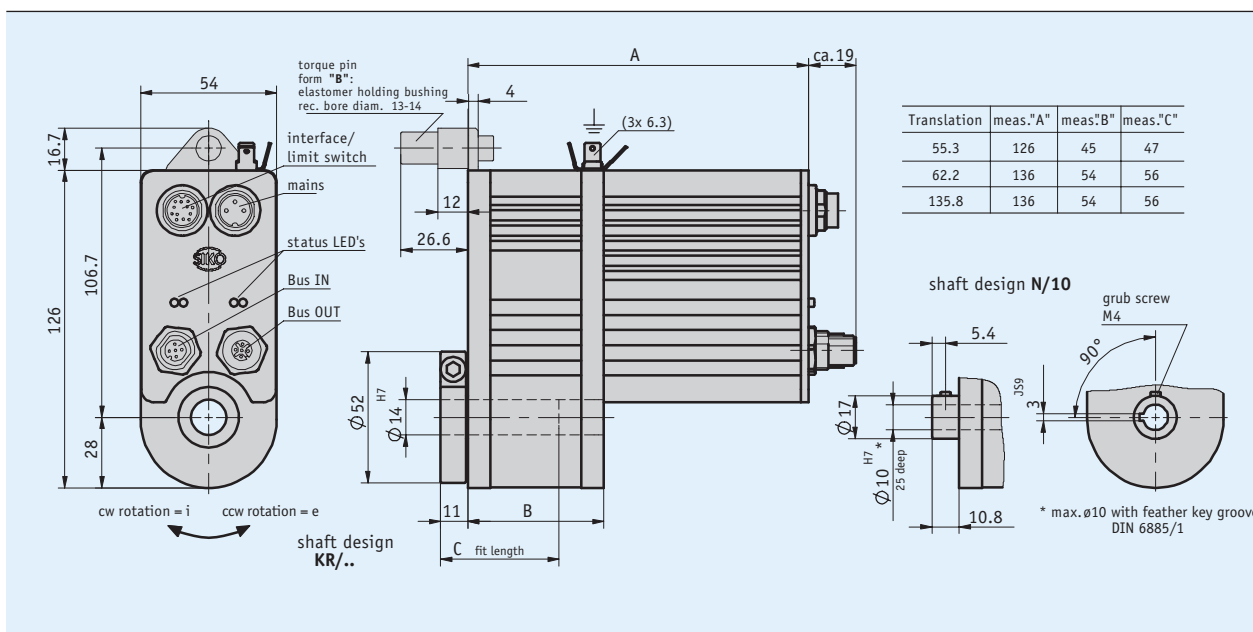

Mechanical data

Feature	Technical data	Additional information
Shaft	black-finished steel	
Housing	aluminum	
Nominal torque/rated speed	5 Nm at 80 rpm 6 Nm at 70 rpm 9 Nm at 35 rpm	i = 55.3 (70 W-M motor) i = 62.2 (70 W-M motor) i = 135.8 (70 W-M motor)
Operating mode	S3 intermittent operation: 25 % DC, 10 min.	EN 60034-1
Weight	~1.2 kg	(Fieldbus)

Electrical data

Motor

Feature	Technical data	Additional information
Operating voltage	24 V DC ± 10 %	reverse polarity protected, fieldbus
Power input	70 W	
Rated current	2.9 A ± 4 % (70 W-M motor) 2.1 A ± 4 % (70 W-M motor)	max. load current i = 55.3 / i = 62.2 max. load current i = 135.8
Type of connection	2x M16 plug connectors -2x M12 plug connectors (A-coded) 2x M12 plug connectors (B-coded)	3-pole, 1x pin; 12-pole, 1x pin 5-pole, 1x pin; 5-pole, 1x socket (CAN) 5-pole, 1x pin; 5-polig, 1x socket (PB)

System data

Feature	Technical data	Additional information
Resolution	1600 intervals/revolution	ABM P10 position encoder
Travel range	±6250 revolution(s) (multiturn)	ABM position encoder

Ambient conditions

Feature	Technical data	Additional information
Ambient temperature	0 ... 50 °C	
Storage temperature	-20 ... 60 °C	
Relative humidity		condensation inadmissible
EMC	EN 61800-3, second environment EN 61800-3, C3	interference resistance / immission emitted interference / emission
Protection category	IP50	EN 60529, mating connectors mounted
Shock resistance	500 m/s ² , 11 ms	EN 60068-2-27
Vibration resistance	100 m/s ² , 5 ... 150 Hz	EN 60068-2-6

Pin assignment

■ Voltage supply

Signal	PIN
+Ub	1
N.C.	2
-Ub	3

■ Fieldbus

Profibus-DP	CANopen	PIN
+5 V DC	N.C.	1
BUS A	N.C.	2
GND	CAN_GND	3
BUS B	CAN_H	4
N.C.	CAN_L	5

■ Interface/limit switch

Signal	PIN
ES1	A
ES2	B
Enable (24 V DC)	C
nc	D
+24 V DC	E
nc	F
RXD/DÜA	G
TXD/DÜB	H
GND/serial interface	J
GND (ES1, ES2, Emergency-off, CAL)	K
CAL	L
GND	M

4.1

Performance curve

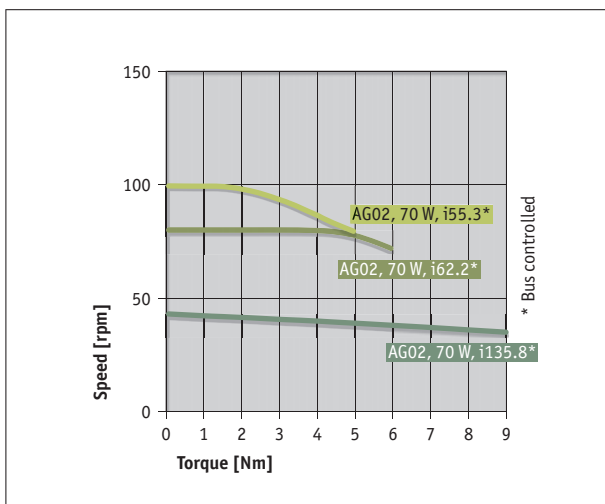

Order

Ordering table

Feature	Ordering data	Specification	Additional information
Gear ratio	55.3	i = 55.3	
	62.2	i = 62.2	
	135.8	i = 135.8	
Shaft design	KR/14	clamping ring, ø14 mm	
	N/10	keyway, ø10 mm	with i=55.3, other transmissions on request
Torque pin	B	lug	incl. elastomer bushing
	OD	without	
Interface	S1/00	RS232, standard, electronic control unit	
	S3/00	RS485, standard, electronic control unit	
Fieldbus	OFB	without fieldbus	
	PB	Profibus-DP	
	CAN	CANopen	

Order key

AG02 Fieldbus - A - 70W-M - B - D - C - LA - ABM - OMS - D - E - SW

Scope of delivery: AG02 Fieldbus, Mounting instructions, Documentation on CD

Accessories:

Cable extension KV02S0	page 60
Cable extension KV12S0	page 78
Programming Tool PT232	www.siko-global.com
Cable adaptor KA232	www.siko-global.com
Programming Tool PT485	www.siko-global.com
Cable adaptor KA485	www.siko-global.com
Programming software ProTool DL	www.siko-global.com
Mating Connector Overview	page 58
Mating connector, motor/voltage supply, 3-pole, socket	Order key 82182
Mating connector, motor/voltage supply, 3-pole, angle socket	Order key 81363
Mating connector, encoder, 12-pole, socket	Order key 76572
Mating connector, encoder, 12-pole, angle socket	Order key 79666
Mating connector, Profibus IN, 5-pole, socket	Order key 83991
Mating connector, Profibus IN, 5-pole, angle socket	Order key 82804
Mating connector, Profibus OUT, 5-pole, pin	Order key 83992
Mating connector, Profibus OUT, 5-pole, angular pin	Order key 82805
Mating connector, CANopen IN, 5-pole, socket	Order key 84109
Mating connector, CANopen IN, 5-pole, angle socket	Order key 83006
Mating connector, CANopen OUT, 5-pole, pin	Order key 84732
Mating connector, CANopen OUT, 5-pole, angular pin	Order key 83007
Bus terminating connector, Profibus, 5-pole, pin	Order key 82816
Bus terminating connector, CANopen, 5-pole, pin	Order key 82815

Additional information:

General information and areas of application page 10

Profile

- Easy mounting
- Optional through hollow shafts up to max. \varnothing 14 mm
- Integrated analog absolute position encoder

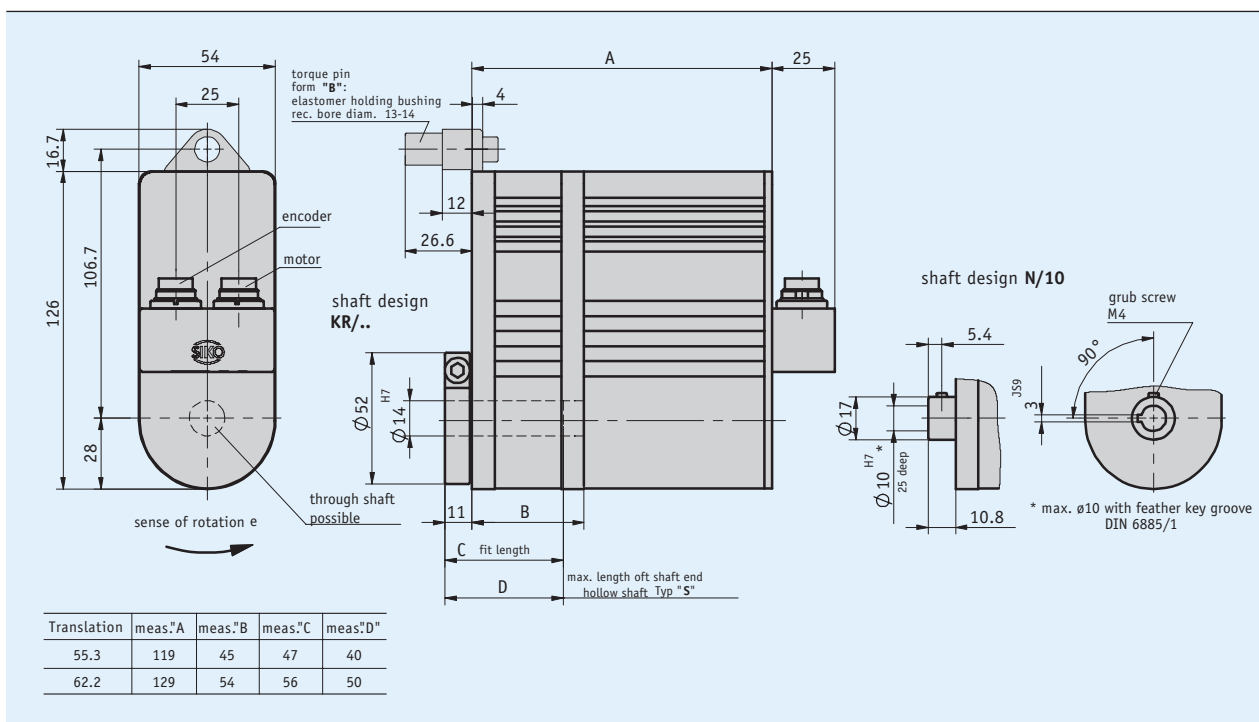

4.1

Mechanical data

Feature	Technical data	Additional information
Shaft	black-finished steel	
Housing	aluminum	
Nominal torque/rated speed	8 Nm at 120 rpm 9 Nm at 110 rpm	i = 55.3 (150 W motor) i = 62.2 (150 W motor)
Operating mode	S3 intermittent operation: 25 % DC, 10 min.	EN 60034-1
Weight	~1.8 kg	(analog)

Electrical data

■ Motor

Feature	Technical data	Additional information
Operating voltage	0 ... 24 V DC	reverse polarity protected
Power input	150 W	
Rated current	5.8 A \pm 4 % (150 W motor)	max. load current i = 55.3 / i = 62.2
Type of connection	2x M16 plug connectors	3-pole, 1x pin; 7-pole, 1x pin

Encoder potentiometer

Feature	Technical data	Additional information
Power rating	2 W at 70 °C	P10 position encoder
Resistance tolerance	±5 %	P10 position encoder
Standard terminal resistance	0.2 % or 1 Ω	P10 position encoder (always the higher value)
Linearity tolerance	±0.25 %	P10 position encoder

Transducer, power output

Feature	Technical data	Additional information
Operating voltage	24 V DC ±20 %	at ≤500 Ω load, reverse polarity protected

Transducer, voltage output

Feature	Technical data	Additional information
Operating voltage	24 V DC ±20 %	$I_{load} \leq 10$ mA, reverse polarity protected

Ambient conditions

Feature	Technical data	Additional information
Ambient temperature	0 ... 70 °C	
Storage temperature	-20 ... 80 °C	
Relative humidity		condensation inadmissible
EMC	EN 61800-3, second environment	interference resistance / immission
	EN 61800-3, C3	emitted interference / emission
Protection category	IP50	EN 60529, mating connectors mounted
Shock resistance	500 m/s ² , 11 ms	EN 60068-2-27
Vibration resistance	100 m/s ² , 5 ... 150 Hz	EN 60068-2-6

Pin assignment

Motor

Signal	PIN
Motor +	1
N.C.	2
Motor -	3

Potentiometer

P01/P10	MWI	MWU	PIN
Pe	I-	GND	1
Po	I+	+24 V DC	2
S	N.C.	Uout	3
N.C.	N.C.	N.C.	4-7

Performance curve

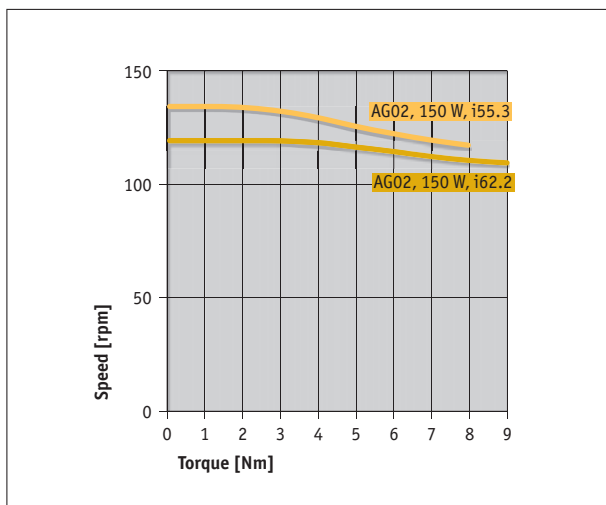

Order

Ordering table

Feature	Ordering data	Specification	Additional information
Gear ratio	55.3	i = 55.3	
	62.2	i = 62.2	
Shaft design/diameter	KR/14	clamping ring, ø14 mm	
	N/10	keyway, ø10 mm	with i=55.3, other transmissions on request
Hollow shaft type	S	blind hole	for the max. length of the stub shaft refer to the table of dimensions
	D	through	
Torque pin	B	lug	incl. elastomer bushing
	OD	without	
Position encoder	MWI	transducer 4 ... 20 mA	10-turn potentiometer
	MWU	transducer 0 ... 10 V	10-turn potentiometer
	P01	potentiometer 1 kΩ	10-turn potentiometer
	P10	potentiometer 10 kΩ	10-turn potentiometer
		others on request	
Potentiometer transmission	...	1 ... 128 max.	
Sense of rotation	i	clockwise ascending values	only with MWI and MWU encoders
	e	counter-clockwise ascending values	only with MWI and MWU encoders

* Calculation of potentiometer gear ratio: For example, if 120 revolutions are required for one adjustment, then a gear ratio of 12 should be indicated for the 10-turn potentiometer. To be precise: number of revolutions required/10 (10-turn potentiometer) = potentiometer gear ratio

Order key

AG02 Analog - - 150W - - - - LR - - - - - OMS - XX/XX - OFB

A
B
C
D
E
F
G

Scope of delivery: AG02 Analog, Mounting instructions

Accessories:

Cable extension KV02S0

page 60

Cable extension KV07S0

page 72

Motor control module MS02

page 56

Electronic display MA50

www.siko-global.com

Mating Connector Overview

page 58

Mating connector, motor/voltage supply, 3-pole, socket

Order key 82182

Mating connector, motor/voltage supply, 3-pole, angle socket

Order key 81363

Mating connector, encoder/digital inputs, 7-pole, socket

Order key 76141

Mating connector, encoder/digital inputs, 7-pole, angle socket

Order key 78088

Additional information:

General information and areas of application

page 10

Profile

- Easy mounting
- Through hollow shafts up to max. $\varnothing 14$ mm
- Integrated magnetic position encoder on output shaft
- Integrated motor control (option)



4.1

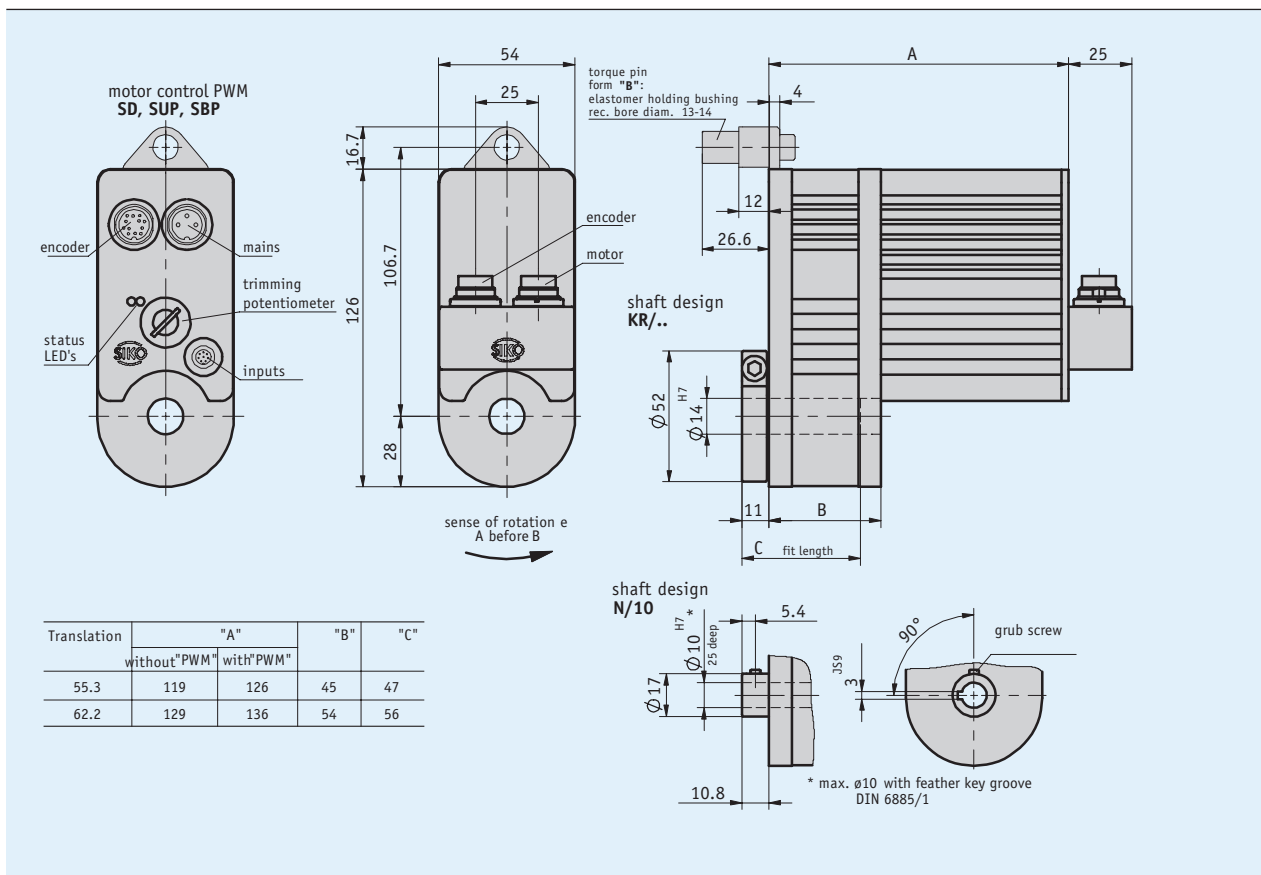

Mechanical data

Feature	Technical data	Additional information
Shaft	black-finished steel	
Housing	aluminum	
Nominal torque/rated speed	5 Nm at 80 rpm	i = 55.3 (70 W-M motor)
	8 Nm at 120 rpm	i = 55.3 (150 W motor)
	6 Nm at 70 rpm	i = 62.2 (70 W-M motor)
	9 Nm at 110 rpm	i = 62.2 (150 W motor)
Operating mode	S3 intermittent operation: 25 % DC, 10 min.	EN 60034-1
Weight	~1.6 kg	(incremental)

Electrical data

Motor

Feature	Technical data	Additional information
Operating voltage	0 ... 24 V DC	reverse polarity protected
	24 V DC $\pm 10\%$	reverse polarity protected, with PWM motor control
Power input	70 W	
	150 W	
Rated current	5.8 A $\pm 4\%$ (150 W motor)	max. load current $i = 55.3 / i = 62.2$
	2.9 A $\pm 4\%$ (70 W-M motor)	max. load current $i = 55.3 / i = 62.2$
Type of connection	2x M16 plug connectors	3-pole, 1x pin; 12-pole, 1x pin

PWM motor control

Feature	Technical data	Additional information
Operating voltage	24 V DC $\pm 20\%$ controlled, with LED indicator	reverse polarity protected
Inputs	digital with LED indicator / analog	
Analog inputs	0 ... 10 V	impedance $> 1.3\text{ M}\Omega$
	-10 ... 10 V	impedance $> 1.3\text{ M}\Omega$
Digital inputs	15 ... 30 V, typical 10 mA	
PWM (Pulse width modulation) input	$\sim 16\text{ kHz}$, continuously variable, 0 ... 100 %	soft start

Encoder

Feature	Technical data	Additional information
Operating voltage	5 V DC $\pm 5\%$	LD5 position encoder, no reverse polarity protection
	24 V DC $\pm 20\%$	LD24 + OP, position encoder, reverse polarity protected
Current consumption	$< 50\text{ mA}$	LD5 position encoder
	$< 25\text{ mA}$	LD24 + OP position encoders
Output circuit	Line Driver (RS422)	LD5 + LD24 position encoders
	Push Pull (OP)	OP position encoder
Output signals	A, B, I, /A, /B, /I	
Pulse frequency	$\leq 20\text{ kHz}$	

4.1

Ambient conditions

Feature	Technical data	Additional information
Ambient temperature	0 ... 50 °C	
	0 ... 70 °C	without motor control, with position encoder
	0 ... 80 °C	without motor control, without position encoder
Storage temperature	-20 ... 80 °C	
Relative humidity		condensation inadmissible
EMC	EN 61800-3, second environment	interference resistance / immission
	EN 61800-3, C3	emitted interference / emission
Protection category	IP50	EN 60529, mating connectors mounted
Shock resistance	500 m/s ² , 11 ms	EN 60068-2-27
Vibration resistance	100 m/s ² , 5 ... 150 Hz	EN 60068-2-6

Pin assignment

Motor/voltage supply

Signal	PIN
Motor+ / +Ub	1
N.C.	2
Motor- / 0 V	3

Encoder

LD24	LD5	PIN
/B	/B	A
nc	+SUB (sensor)	B
/I	/I	C
I	I	D
A	A	E
nc	nc	G
/A	/A	F
B	B	H
nc	nc	J
GND	GND	K
nc	SGND (sensor)	L
+Ub	+Ub	M

PWM motor control

digital	analog unipolar	analog bipolar	PIN
Clockwise rotation plus	Enable plus	Enable plus	1
Clockwise rotation ground	Enable ground	Enable ground	2
Counter-clockwise rotation plus	cw/ccw plus	nc	3
Counter-clockwise rotation ground	cw/ccw ground	nc	4
Fast/creep plus	Analog 0 ... +10 V	Analog 0 ... +10 V	5
Fast/creep ground	Analog ground	Analog ground	6
nc	nc	nc	7
nc	nc	nc	8

Performance curve

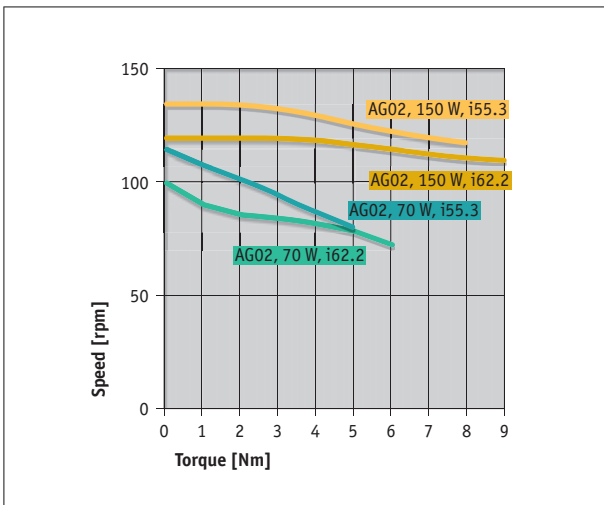

4.1

Order

Ordering table

Feature	Ordering data	Specification	Additional information
Gear ratio	55.3	i = 55.3	
	62.2	i = 62.2	
Motor performance	150W	150 W	
	70W-M	70 W	only with SD, SUP or SBP motor control
Shaft design/diameter	KR/14	clamping ring, ø14 mm	
	N/10	keyway, ø10 mm	with i=55.3, other transmissions on request
Torque pin	B	lug	incl. elastomer bushing
	OD	without	
Position of electrical connection	LR	radial	with external motor control
	LA	axial	with integrated motor control
Position encoder	LD24	incremental 1000 Impulse	+10 ... +30 V DC
	LD5	incremental 1000 Impulse	+5 V DC ±5 %
	OP	push-pull with inverting	+10 ... +30 V DC
	0	without	only with LR "Position of electrical connection"
Motor control pwm	OMS	without	only with 150 W motor power
	SD	digital input	
	SUP	analog input, unipolar 0 ... +10 V	
	SBP	analog input, bipolar -10 ... +10 V	

4.1

Order key

AG02 Incremental - - - - D - - - - - - XX/XX - OFB

A
 B
 C
 D
 E
 F
 G

Scope of delivery: AG02 Incremental, Mounting instructions

Accessories:

Cable extension KV0250	page 60
Cable extension KV0850	page 74
Cable extension KV1250	page 78
Motor control module MS02	page 56
Electronic display MA55	www.siko-global.com
Electronic display MA48	www.siko-global.com
Electronic display MA10/4	www.siko-global.com
Mating Connector Overview	page 58
Mating connector, motor/voltage supply, 3-pole, socket	Order key 82182
Mating connector, motor/voltage supply, 3-pole, angle socket	Order key 81363
Mating connector, encoder, 12-pole, socket	Order key 76572
Mating connector, encoder, 12-pole, angle socket	Order key 79666
Mating connector, motor control, 8-pole, socket	Order key 81351

Additional information:

General information and areas of application page 10

Profile

- Easy mounting
- Through hollow shafts up to max. $\varnothing 14$ mm possible
- Integrated analog absolute position encoder
- Electrical connection via cable or connector

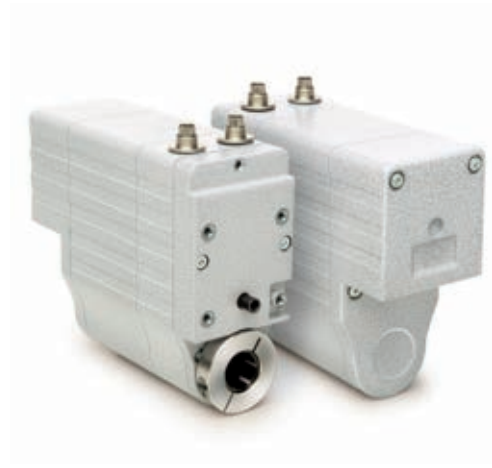

4.1

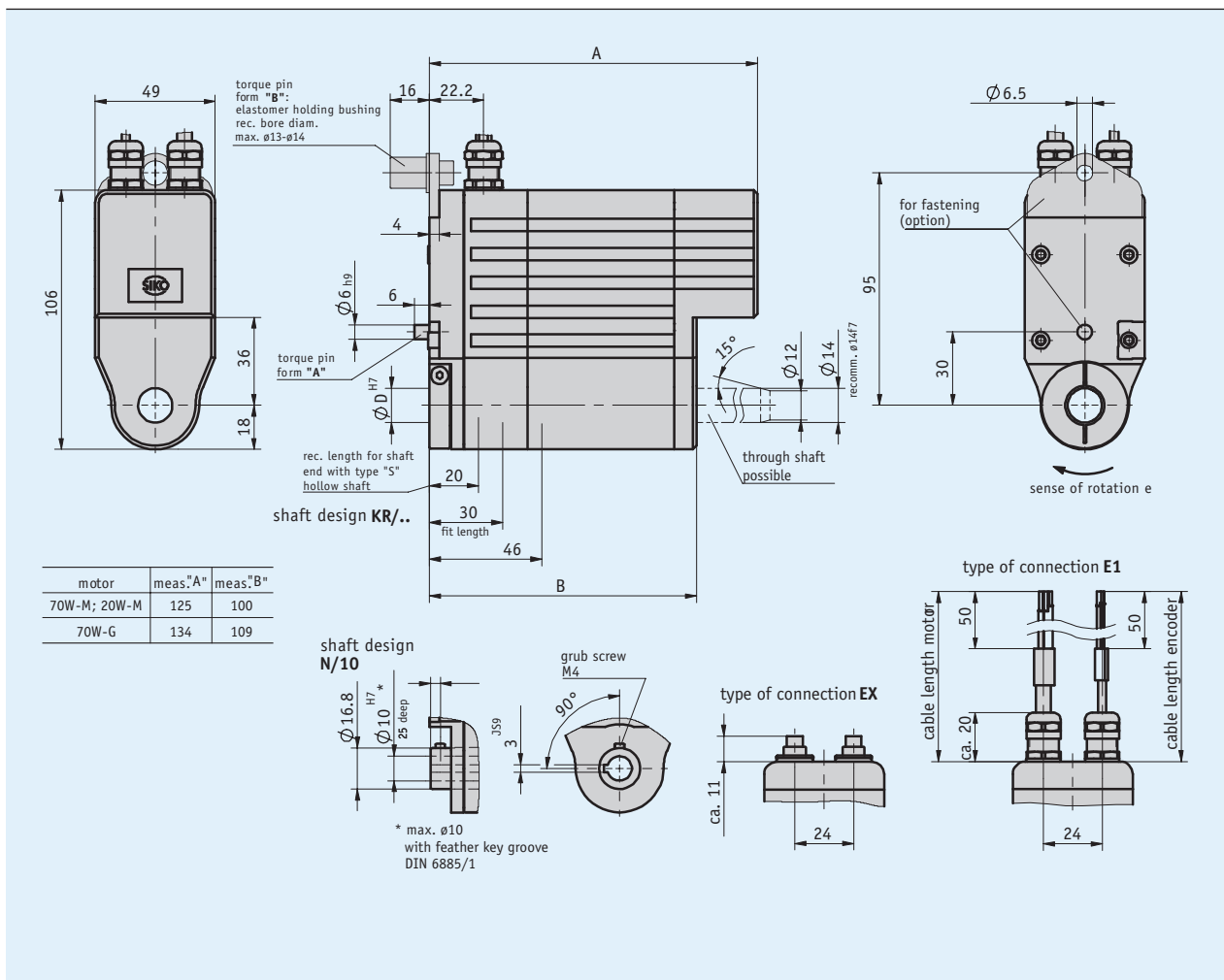

Mechanical data

Feature	Technical data	Additional information
Shaft	black-finished steel	
Housing	aluminum, powder coated zinc die cast	
Nominal torque/rated speed	1.1 Nm, 430 rpm	i = 12.4 (70 W motors)
	2.1 Nm, 225 rpm	i = 24 (70 W motors)
	4.2 Nm, 110 rpm	i = 48 (70 W motors)
Operating mode	S3 intermittent operation: 25 % DC, 10 min.	EN 60034-1
Weight	~1.5 kg	

Electrical data

Motor

Feature	Technical data	Additional information
Operating voltage	0 ... 24 V DC	70 W motors
Power input	70 W	
Rated current	2.9 A ±10 % (70W-M)	3.2 A max. load current
	4.1 A ±10 % (70W-G)	4.5 A max. load current
Type of connection	2x M9 plug connectors	4-pole, 1x pin; 3-pole, 1x pin

Encoder potentiometer

Feature	Technical data	Additional information
Power rating	2 W at 70 °C	P10 position encoder
Resistance tolerance	±5 %	P10 position encoder
Standard terminal resistance	0.2 % or 1 Ω	P10 position encoder (always the higher value)
Linearity tolerance	±0.25 %	P10 position encoder

Transducer, power output

Feature	Technical data	Additional information
Operating voltage	24 V DC ±20 %	at ≤500 Ω load

Transducer, voltage output

Feature	Technical data	Additional information
Operating voltage	24 V DC ±20 %	$I_{load} \leq 10$ mA

Ambient conditions

Feature	Technical data	Additional information
Ambient temperature	0 ... 70 °C	
Storage temperature	-20 ... 80 °C	
Relative humidity		condensation inadmissible
EMC	EN 61800-3, second environment	interference resistance / immission
	EN 61800-3, C3	emitted interference / emission
Protection category	IP63	EN 60529, with mating connectors mounted
Shock resistance	500 m/s ² , 11 ms	EN 60068-2-27
Vibration resistance	100 m/s ² , 50 Hz	EN 60068-2-6

Pin assignment

■ Motor

Signal	EX	E1
+	1	M1, white imprinted
+	2	
-	3	M2, white imprinted
-	4	

■ Potentiometer

Signal	MWU	MWI	EX	E1
Po	+24 V DC	I+	1	brown
S	Uout		2	green
Pe	GND	I-	3	white

Performance curve

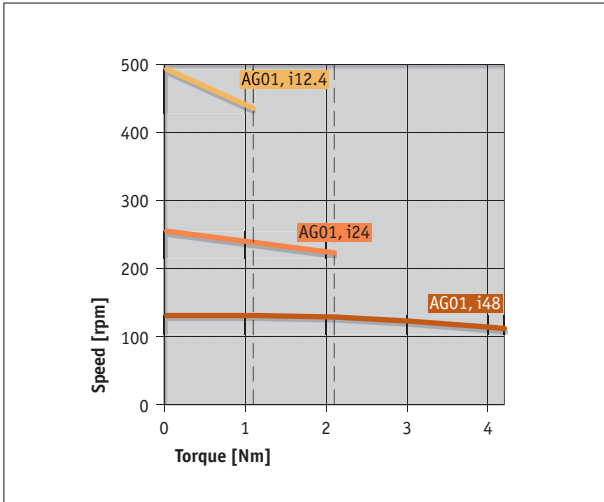

4.1

Order

Ordering table

Feature	Ordering data	Specification	Additional information
Gear ratio	48	i = 48	
	24	i = 24	
	12.4	i = 12.4	
Motor performance	70W-M	24 V DC	
	70W-G	24 V DC	
		others on request	
Shaft design/diameter	KR/14	clamping ring, ø14 mm	
	KR/12	clamping ring, ø12 mm	
	N/10	keyway	only for type S hollow shaft
Hollow shaft type	S	blind hole	
	D	full-length	
Torque pin	A	bolt, ø6 mm	
	B	lug I	incl. elastomer bushing
Type of connection	E1	open cable	
	EX	socket on the device	
Motor cable length	02.0	in m	
		others on request	
Encoder cable length	02.0	in m	
		others on request	
Position encoder	P10	potentiometer 10 kΩ	10 helipot potentiometer
	MWI	transducer 4 ... 20 mA	10 helipot potentiometer
	MWU	transducer 0 ... 10 V	10 helipot potentiometer
		others on request	
Potentiometer transmission	...	1 ... 128 max.	only for P10, MWI and MWU encoders
		others on request	
Sense of rotation	i	clockwise ascending values	only for MWI or MWU encoders
	e	counter-clockwise ascending values	only for MWI or MWU encoders

* Calculation of potentiometer transmission ratio: for instance, if 120 revolutions are required for one adjustment, then the transmission ratio of 12 must be indicated for the 10 helipot potentiometer. In practice: number of necessary revolutions/10 (10 helipot potentiometer) = potentiometer transmission ratio

Order key

AG01 Analog - - - - - - - - - - - -

A B C D E F G H I J K

Scope of delivery: AG01 Analog, Mounting instructions

Accessories:

Cable extension KV0350	page 62
Cable extension KV0450	page 66
Motor control module MS02	page 56
Electronic display MA50	www.siko-global.com
Mating Connector Overview	page 58
Mating connector, motor, 4-pole, socket	Order key 83447
Mating connector, potentiometer, 3-pole, socket	Order key 81487
Mating connector, potentiometer, 3-pole, angle socket	Order key 82366

Additional information:

General information and areas of application	page 10
--	---------

Profile

- Easy mounting
- Through hollow shafts up to max. $\varnothing 14$ mm possible
- Integrated magnetic position encoder on output shaft
- Electrical connection via cable or connector

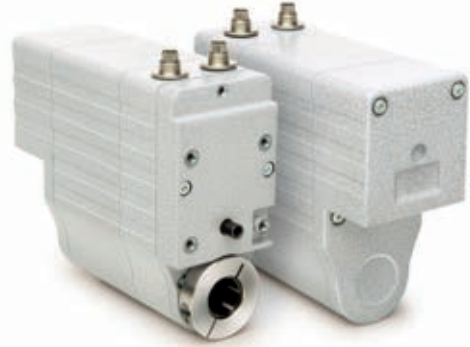

4.1

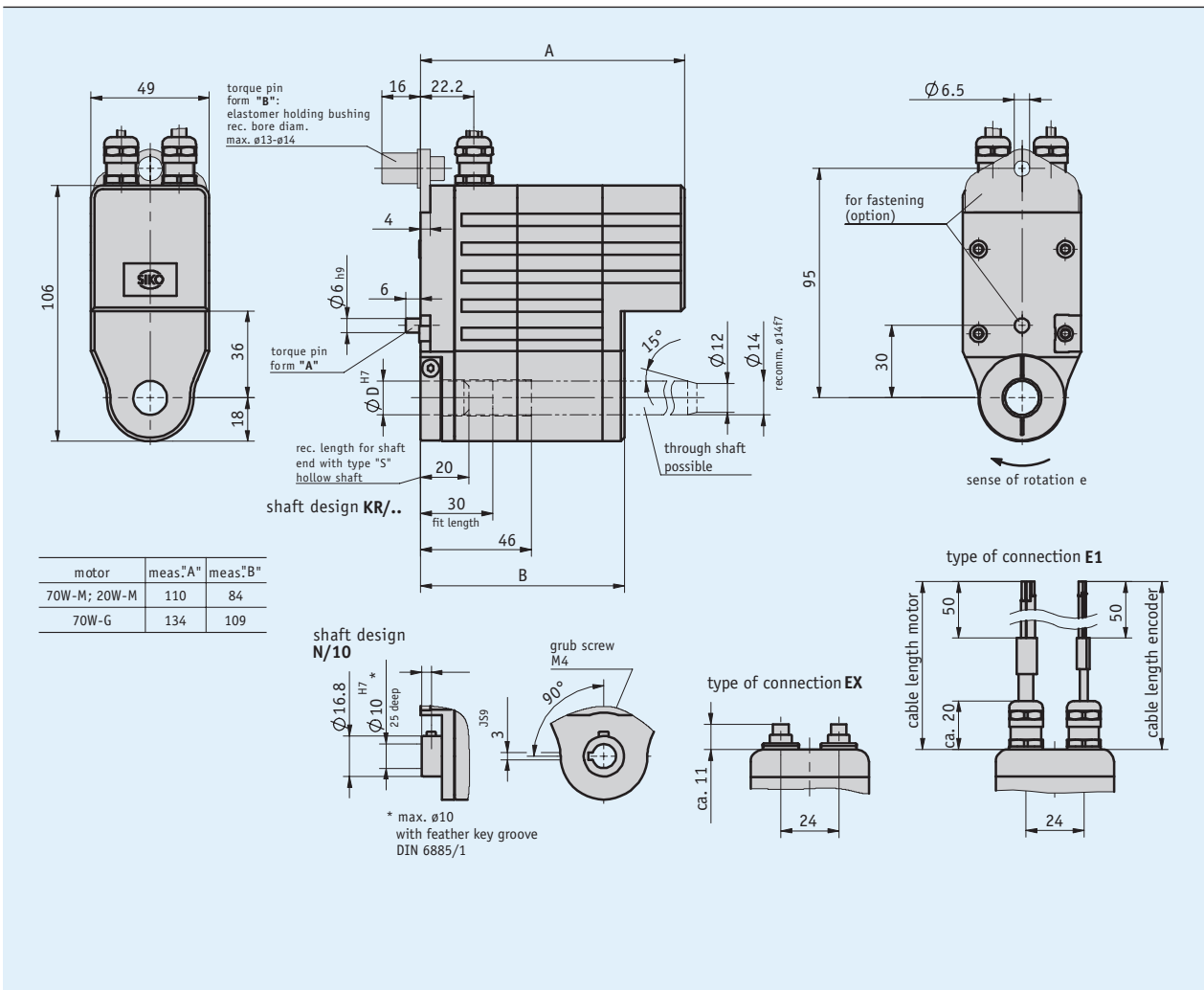

Mechanical data

Feature	Technical data	Additional information
Shaft	black-finished steel	
Housing	aluminum, powder coated zinc die cast	
Nominal torque/rated speed	1.1 Nm, 430 rpm	i = 12.4 (70 W motors)
	2.1 Nm, 225 rpm	i = 24 (70 W motors)
	4.2 Nm, 110 rpm	i = 48 (70 W motors)
Operating mode	S3 intermittent operation: 25 % DC, 10 min.	EN 60034-1
Weight	~1.5 kg	

Electrical data

Motor

Feature	Technical data	Additional information
Operating voltage	0 ... 24 V DC	70 W motors
Power input	70 W	
Rated current	2.9 A ±10 % (70W-M)	3.2 A max. load current
	4.1 A ±10 % (70W-G)	4.5 A max. load current
Type of connection	2x M9 plug connectors	4-pole, 1x pin; 8-pole, 1x pin

Encoder

Feature	Technical data	Additional information
Operating voltage	5 V DC ±5 %	LD5 position encoder
	24 V DC ±20 %	LD24 + OP position encoder
Current consumption	≤35 mA	
Output circuit	Line Driver (RS422)	LD5 + LD24 position encoders
	Push Pull (OP)	OP position encoder
Output signals	A, B, 0, /A, /B, I	
Pulse frequency	≤20 kHz	

4.1

Ambient conditions

Feature	Technical data	Additional information
Ambient temperature	0 ... 70 °C	
	0 ... 80 °C	without position encoder
Storage temperature	-20 ... 80 °C	
Relative humidity		condensation inadmissible
EMC	EN 61800-3, second environment	interference resistance / immission
	EN 61800-3, C3	emitted interference / emission
Protection category	IP63	EN 60529, with mating connectors mounted
Shock resistance	500 m/s ² , 11 ms	EN 60068-2-27
Vibration resistance	100 m/s ² , 50 Hz	EN 60068-2-6

Pin assignment

■ Motor

Signal	EX	E1
+	1	M1, white imprinted
+	2	
-	3	M2, white imprinted
-	4	

■ Encoder

Signal	EX	E1
B	1	white
+UB	2	brown
0	3	green
A	4	yellow
GND	5	gray
/A	6	pink
/B	7	blue
I	8	red

Performance curve

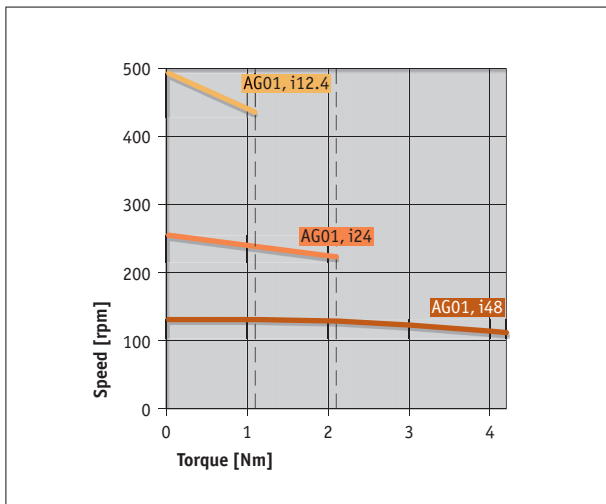

4.1

Order

Ordering table

Feature	Ordering data	Specification	Additional information
Gear ratio	48	i = 48	
	24	i = 24	
	12.4	i = 12.4	
Motor performance	70W-M	24 V DC	
	70W-G	24 V DC	
		others on request	
Shaft design/diameter	KR/14	clamping ring, ø14 mm	
	KR/12	clamping ring, ø12 mm	
	N/10	keyway	only for type S hollow shaft
Hollow shaft type	S	blind hole	
	D	full-length	
Torque pin	A	bolt, ø6 mm	
	B	lug I	incl. elastomer bushing
Type of connection	E1	open cable	
	EX	socket on the device	
Motor cable length	02.0	in m	
		others on request	
Encoder cable length	02.0	in m	
		others on request	
Position encoder	LD24	incremental encoder 1024 pulses	
	LD5	incremental encoder 1024 pulses	
	OP	Push-pull with inverting	
	0	without	

4.1

Order key



Scope of delivery: AG01 Incremental, Mounting instructions

Accessories:

- Cable extension KV04S0 page 66
- Cable extension KV08S0 page 74
- Motor control module MS02 page 56
- Electronic display MA55 www.siko-global.com
- Electronic display MA48 www.siko-global.com
- Electronic display MA10/4 www.siko-global.com
- Mating Connector Overview page 58
- Mating connector, motor, 4-pole, socket Order key 83447
- Mating connector, encoder, 8-pole, socket Order key 81351

Additional information:

General information and areas of application page 10

4.2



4.0 | Overview 3
4.1 | Actuators 9

4.2 | Accessories

Products		
	Motor control module MS02	56
	Mating Connector Overview	58
	Cable extension KV02S0	60
	Cable extension KV03S0	62
	Cable extension KV03S1	64
	Cable extension KV04S0	66
	Cable extension KV04S1	68
	Cable extension KV04S2	70
	Cable extension KV07S0	72
	Cable extension KV08S0	74
	Cable extension KV08S2	76
	Cable extension KV12S0	78

4.3 | Appendix 81
4.4 | Product index, contact information 85

4.0

4.1

4.2

4.3

4.4

Profile

- Easy mounting (top-hat rail)
- Variable control variants
- Use with different positioning controls
- Fast or creep motion continuously variable
- Pulse width modulation (PWM) for 24 V DC actuators

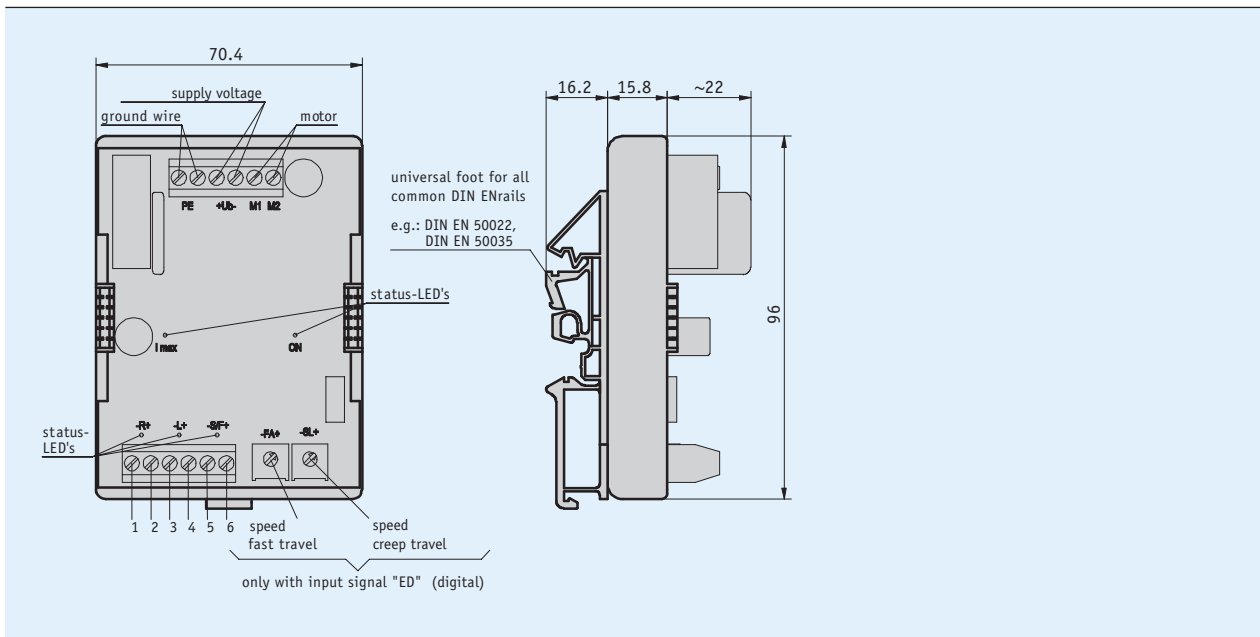

Electrical data

Feature	Technical data	Additional information
Operating voltage	24 V DC ±20 % (controlled)	with LED indicator, reverse polarity protected
Motor current	3/5/6 A (≤12 A peak)	overcurrent protection with multifuse
Inputs	digital with LED indicator/ analog	
Analog inputs	0 ... 10 V -10 ... 10 V	impedance >1.3 MΩ impedance >1.3 MΩ
Digital inputs	15 ... 30 V, typical 10 mA	
Status display	overcurrent protection, input state, operating voltage	
PWM (Pulse width modulation) output	~16 kHz, stepless, 0 ... 100 %	soft start

Ambient conditions

Feature	Technical data	Additional information
Ambient temperature	0 ... 50 °C	
Relative humidity	≤95 %	condensation inadmissible

4.2

Pin assignment

Terminal board

Digital	Analog unipolar	Analog bipolar	PIN
Clockwise ground	enable ground	enable ground	1
Clockwise plus	enable plus	enable plus	2
Counter-clockwise ground	cw/ccw ground	N.C.	3
Counter-clockwise plus	cw/ccw plus	N.C.	4
Fast/creep ground	analog ground	analog ground	5
Fast/creep plus	analog 0 ... +10 V	analog 0 ... +10 V	6

Functional diagram

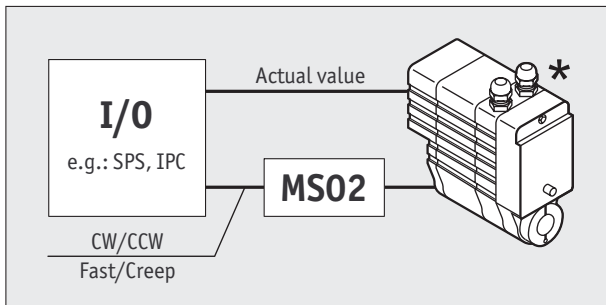

* possible field of application with AG01, AG02

4.2

Order

Ordering table

Feature	Ordering data	Specification	Additional information
Load current	3A	3 A	others on request, max. 12 A
	5A	5 A	
	6A	6 A	
Input signal	ED	digital	
	EUP	analog unipolar	0 ... +10 V, impedance >1.3 MΩ
	EBP	analog bipolar	-10 ... +10 V, Impedanz >1.3 MΩ

Order key

MS02 - -

Scope of delivery: MS02, Mounting instructions

Profile

- Mating connector, straight
- Mating connector, offset
- D-SUB connector
- Bus terminator, straight

 When screwed, the distance to the device will increase by approx. 3 mm.



4.2

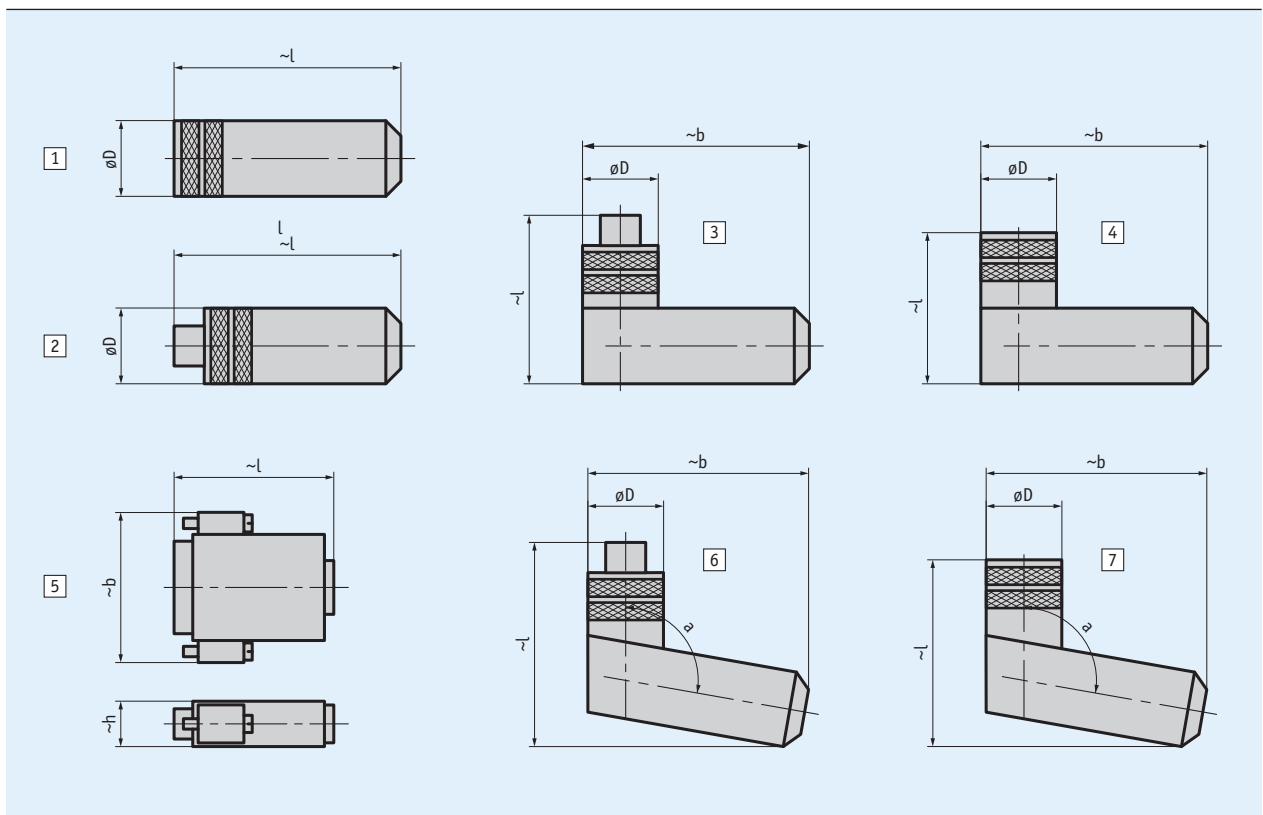

Order

■ Overview of orders

Order key	Picture	Type	PIN	Name	ø Cable	øD	l	b	h	a
71364+71365	5	D-SUB	9	pin+shell	≤8.5		35	31	15.5	
71366+71365	5	D-SUB	9	socket+shell	≤8.5		35	31	15.5	
73947+73946	5	D-SUB	15	socket+shel	≤8.5		42	40	15.2	
76141	1	M16	7	socket	4 ... 6	18.5	61			
76572	1	M16	12	socket	6 ... 8	18.5	62			
77087	1	M16	7	socket	6 ... 8	18.5	62			
78088	4	M16	7	angle socket	4 ... 6	20	38	54		
79665	4	M16	7	angle socket	6 ... 8	20	38	54		
79666	4	M16	12	angle socket	6 ... 8	20	38	54		
81351	1	M9	8	socket	3.5 ... 5	14	38			
81363	4	M16	3	angle socket	4 ... 6	20	38	54		
81487	1	M9	3	socket	3.5 ... 5	14	38			
81935	1	M23	12	socket	≤8.5	26	51.1			
82182	1	M16	3	socket	4 ... 6	18.5	61			
82247	4	M9	4	angle socket	3.5 ... 5	14	30	30.5		
82366	4	M9	3	angle socket	3.5 ... 5	14	30	30.5		
82804	7	M12 B-Cod.	5	angle socket	4 ... 8	19	48	41		100°
82805	6	M12 B-Cod.	5	angular pin	4 ... 8	19	50	41		100°
82815	2	M12 A-Cod.	5	bus terminating plug (CAN)		14.5	55			
82816	2	M12 B-Cod.	5	bus terminating plug (PB)		14.2	44			
83006	7	M12 A-Cod.	5	angle socket	4 ... 8	19	48	41		100°
83007	6	M12 A-Cod.	5	angular pin	4 ... 8	19	50	41		100°
83091	7	M12 A-Cod.	4	angle socket	4 ... 8	19	48	41		100°
83419	1	M12 A-Cod.	4	socket	4 ... 6	20	54			
83447	1	M9	4	socket	3.5 ... 5	14	38			
83525	1	M12 A-Cod.	8	socket	6 ... 8	20	57			
83526	1	M12 A-Cod.	4	socket	6 ... 8	20	57			
83527	2	M12 A-Cod.	8	pin	6 ... 8	20	62			
83991	1	M12 B-Cod.	5	socket	6 ... 8	20	57			
83992	2	M12 B-Cod.	5	pin	6 ... 8	20	62			
84109	1	M12 A-Cod.	5	socket	6 ... 8	20	57			
84209	1	M8	4	socket	3.5 ... 5	12	43			
84210	2	M8	4	pin	3.5 ... 5	12	50			
84732	2	M12 A-Cod.	5	pin	6 ... 8	20	62			
85057	1	M16	3	socket	6 ... 8	18.5	62			
85058	4	M16	3	angle socket	6 ... 8	20	38	54		
85277	1	M12 A-Cod.	12	socket	6 ... 8	20	57			
85278	4	M12 A-Cod.	12	angle socket	6 ... 8	20	38	54		
87599	7	M12 A-Cod.	8	angle socket	4 ... 8	19	48	41		100°
87600	3	M12 D-Cod.	4	angular pin	6 ... 8	20	42	54		
87601	2	M12 D-Cod.	4	pin	6 ... 8	20	63			
BAS-0005	2	M8	4	bus terminating plug		12	45			

■ Order key



Scope of delivery: mating connector

Profile

- Ready-to-use cable connection
- Cable lengths up to 20 m
- Connection technology M16, 3-pole

 Voltage drop should be envisaged with increasing cable length. This should be taken into account for the electrical design.

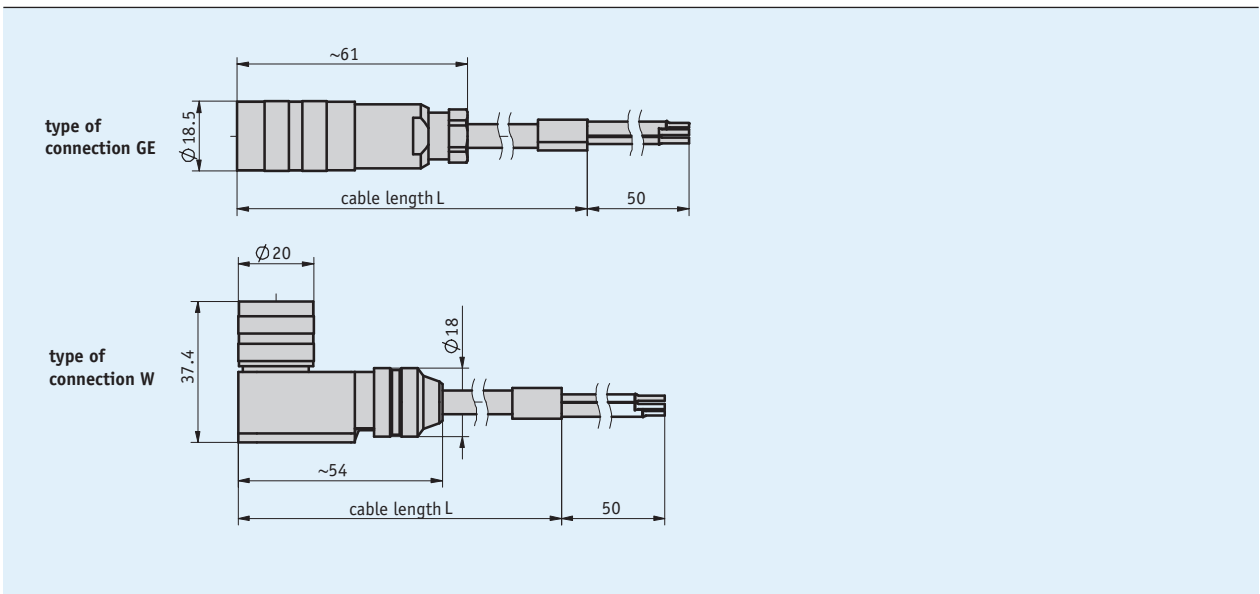

Mechanical data

Feature	Technical data	Additional information
Cable sheath	PVC	2x 0.75 mm ² , ø6.3 mm

Ambient conditions

Feature	Technical data	Additional information
Ambient temperature	-5 ... 80 °C	

Pin assignment

■ KV02S0

Cable number	PIN
1 (black)	1
	2
2 (black)	3

Order

■ Ordering table

Feature	Ordering data	Specification	Additional information
Type of connection	GE	straight connector	
	W	right angle plug	
Cable length	... B	01.0 ... 20.0 m, in steps of 1 m	

■ Order key



Scope of delivery: KV02S0

Profile

- Ready-to-use cable connection
- Cable lengths up to 20 m
- Connection technology M9, 3-pole

 Voltage drop should be envisaged with increasing cable length. This should be taken into account for the electrical design.



4.2

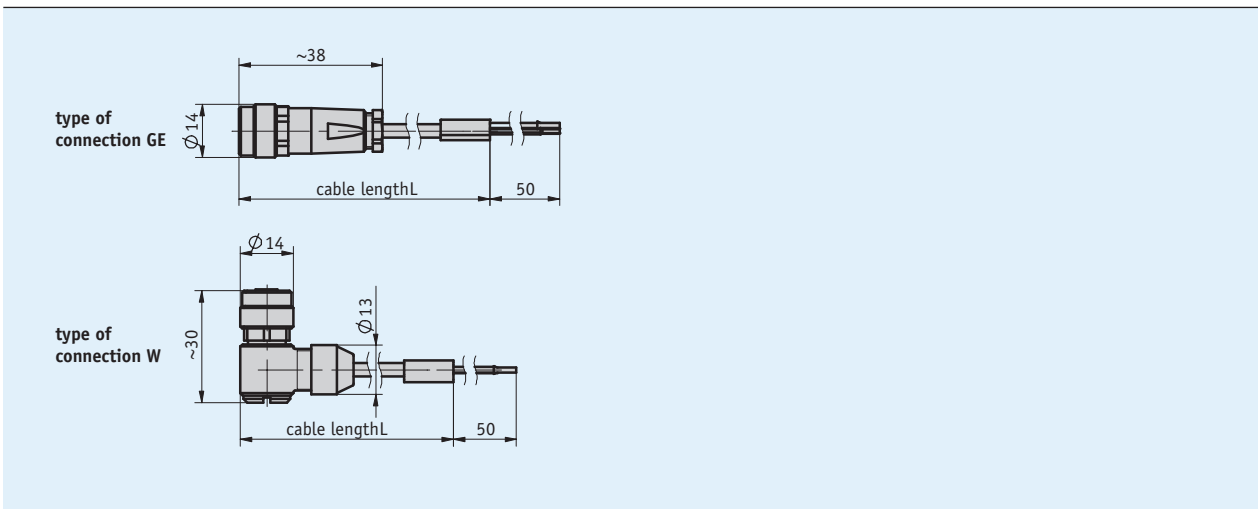

Mechanical data

Feature	Technical data	Additional information
Cable sheath	PUR	3x 0.15 mm ² , $\varnothing 3.5$ mm

Ambient conditions

Feature	Technical data	Additional information
Ambient temperature	-30 ... 85 °C	

Pin assignment

■ KV03S0

Cable color	PIN
brown	1
green	2
white	3

Order

■ Ordering table

Feature	Ordering data	Specification	Additional information
Type of connection	GE	straight connector	
	W	right angle plug	
Cable length	...	01.0 ... 20.0 m, in steps of 1 m	

■ Order key

KV03S0 - -

Scope of delivery: KV03S0

Profile

- Ready-to-use cable connection
- Cable lengths up to 10 m
- Connection technology M16, 3-pole

! Voltage drop should be envisaged with increasing cable length. This should be taken into account for the electrical design.



4.2

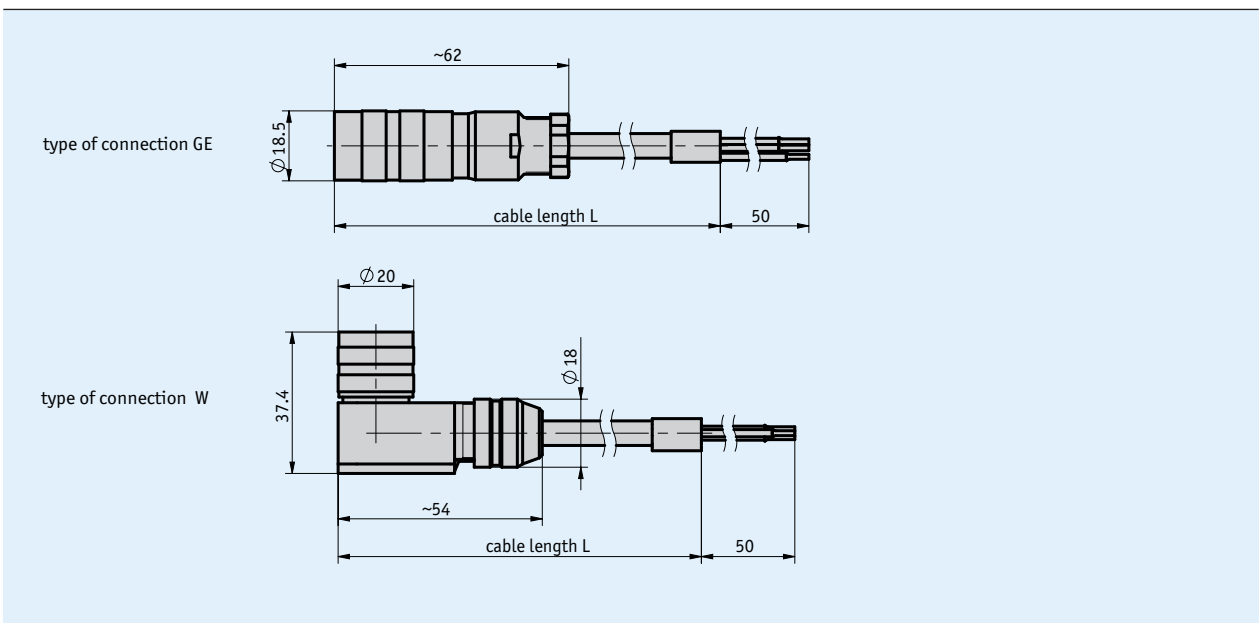

Mechanical data

Feature	Technical data	Additional information
Cable sheath	PUR	3x 0.75 mm ² , ø7.5 mm

Ambient conditions

Feature	Technical data	Additional information
Ambient temperature	-5 ... 70 °C	

Pin assignment

■ KV03S1

Cable number	PIN
1 (black)	1
2 (black)	2
3 (black)	3

Order

■ Ordering table

Feature	Ordering data	Specification	Additional information
Type of connection	GE	straight connector	
	W	right angle plug	
Cable length	...	01.0 ... 10.0 m, in steps of 1 m	

■ Order key

KV03S1 - -

Scope of delivery: KV03S1

Profile

- Ready-to-use cable connection
- Cable lengths up to 20 m
- Connection technology M9, 4-pole



Voltage drop should be envisaged with increasing cable length. This should be taken into account for the electrical design.

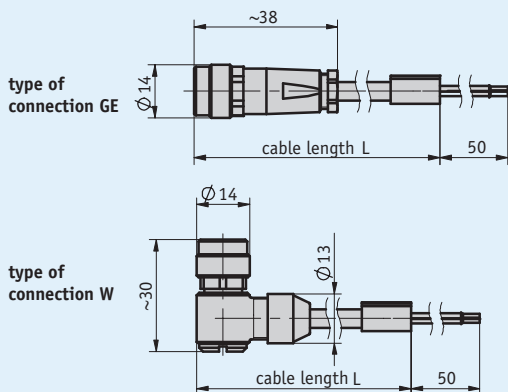

Mechanical data

Feature	Technical data	Additional information
Cable sheath	PVC	4x 0.15 mm ² , Ø4.8 mm

Ambient conditions

Feature	Technical data	Additional information
Ambient temperature	-5 ... 70 °C	

Pin assignment

■ KV04S0

Cable color	PIN
white	1
brown	2
green	3
yellow	4

Order

■ Ordering table

Feature	Ordering data	Specification	Additional information
Type of connection	GE	straight connector	
	W	right angle plug	
Cable length	...	01.0 ... 20.0 m, in steps of 1 m	

■ Order key

KV04S0 - -

Scope of delivery: KV04S0

Profile

- Ready-to-use cable connection
- Cable lengths up to 10 m
- Connection technology M8, 4-pole

! Voltage drop should be envisaged with increasing cable length. This should be taken into account for the electrical design.

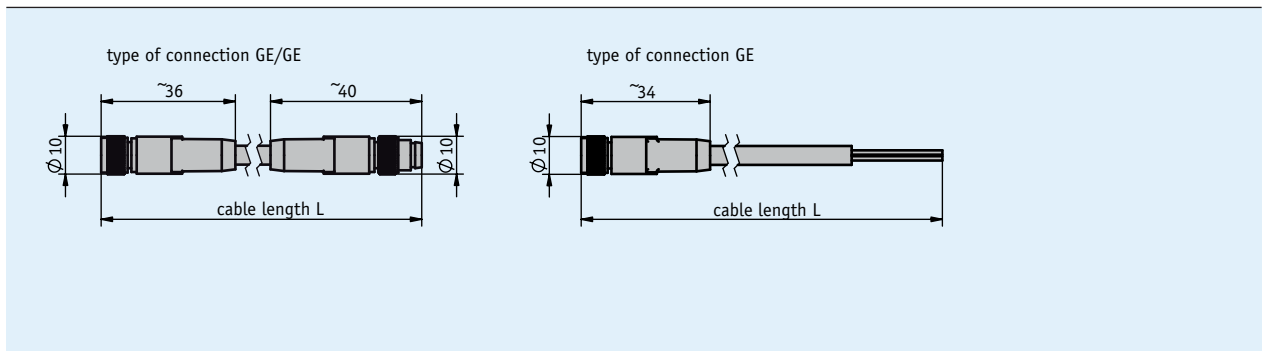

Mechanical data

Feature	Technical data	Additional information
Cable sheath	PUR	ø4.5 mm

Ambient conditions

Feature	Technical data	Additional information
Ambient temperature	-25 ... 80 °C	

Pin assignment

■ KV04S1

Cable color	PIN
brown	1
white	2
blue	3
black	4

Order

■ Ordering table

Feature	Ordering data	Specification	Additional information
Type of connection	GE	straight connector	only with cable length 03.0 or 10.0 m
	GE/GE	2x straight connector	
Cable length	...	00.5, 01.0, 03.0, 05.0, 10.0 m	
		others on request	

■ Order key

KV04S1 - -

Scope of delivery: KV04S1

Profile

- Ready-to-use cable connection
- Cable lengths up to 10 m
- Connection technology M12 (A-coded), 4-pole

! Voltage drop should be envisaged with increasing cable length. This should be taken into account for the electrical design.



4.2

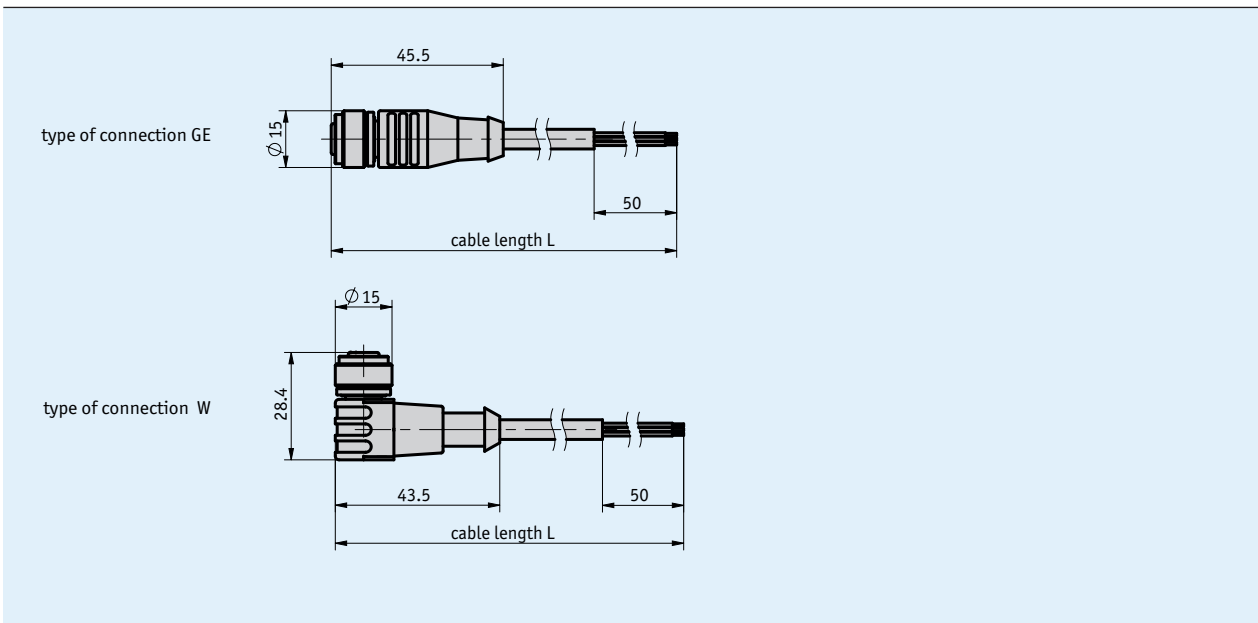

Mechanical data

Feature	Technical data	Additional information
Cable sheath	PUR	4x 0.34 mm ² , ø5.2 mm

Ambient conditions

Feature	Technical data	Additional information
Ambient temperature	-30 ... 90 °C	PUR

Pin assignment

Cable color	PIN
brown	1
white	2
blue	3
black	4

Order

Ordering table

Feature	Ordering data	Specification	Additional information
Type of connection	GE	straight connector	
	W	angular connector	
Cable length	...	02.0, 05.0, 10.0 m	

Order key

KV04S2 - -

Scope of delivery: KV04S2

Profile

- Ready-to-use cable connection
- Cable lengths up to 20 m
- Connection technology M16, 7-pole



Voltage drop should be envisaged with increasing cable length. This should be taken into account for the electrical design.



type of connection GE

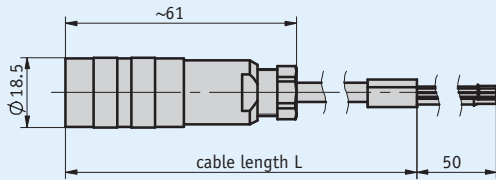

type of connection W

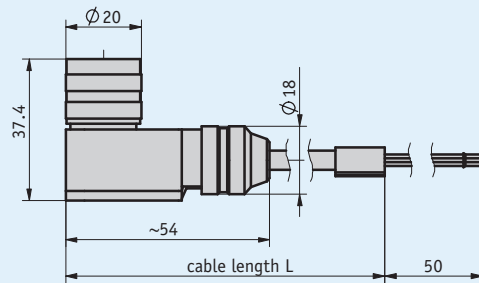

Mechanical data

Feature	Technical data	Additional information
Cable sheath	PUR	7x 0.14 mm ² , ø5.1 mm

Ambient conditions

Feature	Technical data	Additional information
Ambient temperature	-5 ... 50 °C	

Pin assignment

■ KV07S0

Cable color	PIN
white	1
brown	2
green	3
yellow	4
gray	5
pink	6
blue	7

Order

■ Ordering table

Feature	Ordering data	Specification	Additional information
	...	00.2 ... 20.0 m, in steps of 1 m	

■ Order key

KV07S0 - GE/GE -

Scope of delivery: KV07S0

Profile

- Ready-to-use cable connection
- Cable lengths up to 15 m
- Connection technology M9, 8-pole



Voltage drop should be envisaged with increasing cable length. This should be taken into account for the electrical design.

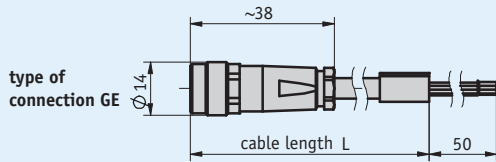

Mechanical data

Feature	Technical data	Additional information
Cable sheath	PVC	8x 0.14 mm ² , ø5.4 mm

Ambient conditions

Feature	Technical data	Additional information
Ambient temperature	-5 ... 50 °C	

4.2

Pin assignment

■ KV08S0

Cable color	PIN
white	1
brown	2
green	3
yellow	4
gray	5
pink	6
blue	7
red	8

Order

■ Ordering table

Feature	Ordering data	Specification	Additional information
	...	01.0 ... 10.0 m, in steps of 1 m	
	...	12.0, 14.0, 15.0 m	

■ Order key

KV08S0 - GE -

Scope of delivery: KV08S0

Profile

- Ready-to-use cable connection
- Cable lengths up to 20 m
- Connection technology M12 (A-coded), 8-pole

 *Voltage drop should be envisaged with increasing cable length. This should be taken into account for the electrical design.*



type of connection GE

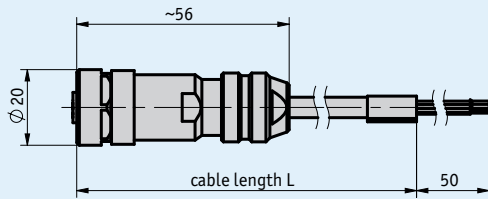

Mechanical data

Feature	Technical data	Additional information
Cable sheath	PUR	8x 0.14 mm ² , ø5.4 mm

Ambient conditions

Feature	Technical data	Additional information
Ambient temperature	-25 ... 85 °C	

Pin assignment

Cable color	PIN
white	1
brown	2
green	3
yellow	4
gray	5
pink	6
blue	7
red	8

Order

Ordering table

Feature	Ordering data	Specification	Additional information
Cable length	... A	1 ... 20 m, in steps of 1 m	

Order key

KV08S2 - GE -

Scope of delivery: KV08S2

Profile

- Ready-to-use cable connection
- Cable lengths up to 20 m
- Connection technology M16, 12-pole



Voltage drop should be envisaged with increasing cable length. This should be taken into account for the electrical design.



type of connection GE

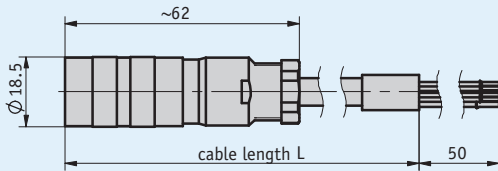

type of connection W

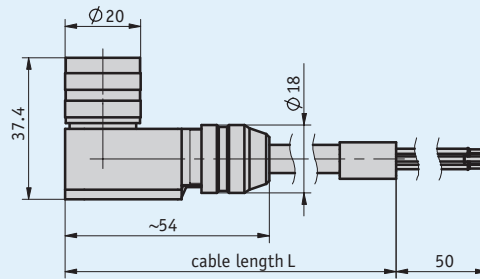

Mechanical data

Feature	Technical data	Additional information
Cable sheath	PUR	12x 0.25 mm ² , ø7.3 mm

Ambient conditions

Feature	Technical data	Additional information
Ambient temperature	-5 ... 50 °C	

Pin assignment

■ KV12S0

Cable color	PIN
blue	A
violet	B
green	C
red	D
yellow	E
pink	F

Cable color	PIN
red-blue	G
white	H
gray-pink	J
gray	K
black	L
brown	M

Order

■ Ordering table

Feature	Ordering data	Specification	Additional information
Type of connection	GE	straight connector	
	W	right angle plug	
Cable length	...	01.0 ... 20.0 m, in steps of 1 m	

■ Order key

KV12S0 - -

Scope of delivery: KV12S0

4.3

[mm]

tolérance

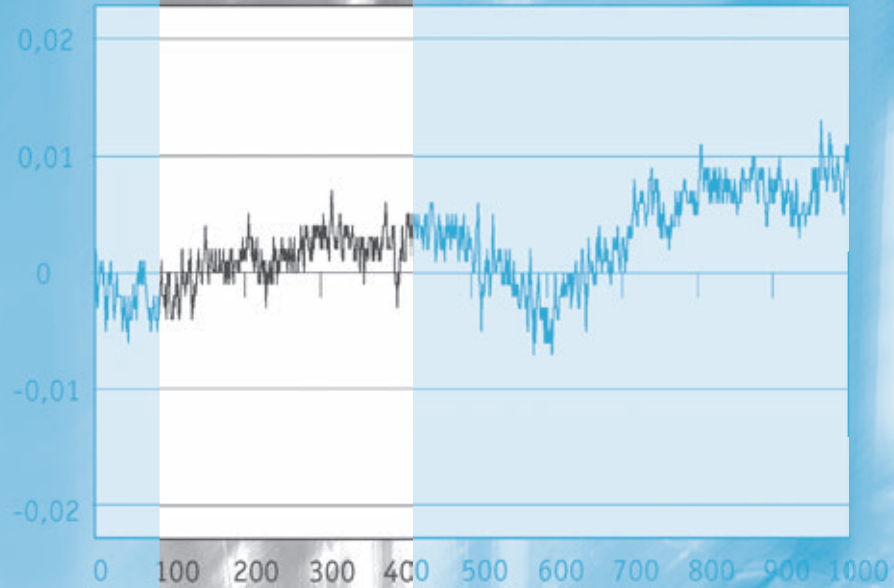

longueur L [mm]



4.0 Overview	3
4.1 Actuators	9
4.2 Accessories	55

4.3 | Appendix

Overview of IP protection classes	82
--	-----------

4.4 Product index, contact information	85
--	----

4.0

4.1

4.2

4.3

4.4

Protection classes according to DIN EN 60529

IP ..

Touch and foreign bodies protection

Icon	Class	Description
	0	No protection.
	1	Protected against access with the back of the hand. Protection against solid foreign bodies with $\varnothing > 50$ mm.
	2	Protected against contact with a finger. Protected against solid foreign bodies with diameters > 12.5 mm.
	3	Protected against access with a tool. Protected against solid foreign bodies with diameters > 2.5 mm.
	4	Protected against access with a wire. Protected against solid foreign bodies with diameters > 1.0 mm.
	5	Full protection against contact. Protection against harmful quantities of dust.
	6	Full protection against contact. Dust-proof.

Water protection

Icon	Class	Description
	0	No protection.
	1	Protection against vertical water drips.
	2	Protection against vertical water drips if the housing is tilted up to $\pm 15^\circ$.
	3	Protection against spray up to $\pm 60^\circ$ towards verticality.
	4	Protection against splash water coming from any angle.
	5	Protection against hose water (nozzle) coming from any angle.
	6	Protection against strong hose water coming from any angle.
	7	Protection against temporary immersion.
	8	Protection against continuous immersion.
	9k*	Protection against ingress of water during high pressure or steam-jet cleaning, specific for road vehicles.

The standards deal with the protection of electric equipment by means of housings, covers and so forth. For purely mechanical devices, the information is used figuratively.

The two numbers are not indicative of the protection against ingress of oils or similar liquids. The second figure indicates the protection class exclusively for water.

* IPx9k is not part of DIN EN 60 529, rather it is contained in DIN 40 050

4.3

4.44



4.0 Overview	3
4.1 Actuators	9
4.2 Accessories	55
4.3 Appendix	81

4.4 | Product index, contact information

Product index	86
contact information	87

4.0

4.1

4.2

4.3

4.4

KV04S2

AG04B

AG26

MS02

device	type	page
A		
AG01 Analog	Actuator	46
AG01 Incremental	Actuator	50
AG02 Analog	Actuator	39
AG02 Fieldbus	Actuator	36
AG02 Incremental	Actuator	42
AG03/1 Fieldbus	Actuator	32
AG04B Fieldbus	Actuator	28
AG05 Fieldbus	Actuator	25
AG06 Fieldbus	Actuator	22
AG25 Fieldbus/IE	Actuator	19
AG26 Fieldbus/IE	Actuator	16
K		
KV02S0	Cable extension	60
KV03S0	Cable extension	62
KV03S1	Cable extension	64
KV04S0	Cable extension	66
KV04S2	Cable extension	70
KV07S0	Cable extension	72
KV08S0	Cable extension	74
KV08S2	Cable extension	76
KV12S0	Cable extension	78
M		
Mating Connector Overview		58
MS02	Motor control module	56

4.4

Do you want to contact an agency near you?

Visit our website www.siko-global.com, and go to the „Contact“ menu item to access all the latest contact data of our agencies.

Africa

Egypt
South Africa

Asia

Canada
China
India
Indonesia
Iraq
Iran
Israel
Japan
Malaysia
Singapore
South Korea
Taiwan
Thailand
United Arab Emirates
Vietnam

Australia

Australia
New Zealand

Europe

Austria
Belarus
Belgium
Bulgaria
Croatia
Cyprus
Czech Republic
Denmark
Estonia
Finland
France
Germany
Great Britain
Greece
Hungary
Italy
Latvia
Lichtenstein
Lithuania
Luxembourg
Montenegro
Netherlands
Norway
Poland
Portugal
Romania
Russia
Serbia
Slovakia
Slovenia
Spain
Sweden
Switzerland
Turkey
Ukraine

America

Argentina
Brazil
Canada
Ecuador
Mexico
USA





Headquarters:

 **SIKO GmbH**
Weihermattenweg 2
D-79256 Buchenbach

Phon

+49 7661 394-0

Fax

+49 7661 394-388

E-Mail

info@siko.de

Subsidiaries:

 **SIKO Products Inc**

 **SIKO Italia S.r.l.**

 **SIKO Magline AG**

 **SIKO International Trading (Shanghai) CO., Ltd.**

 **SIKO Products Asia Pte. Ltd.**

www.siko-global.com