

Made in Germany

ATEK

ANTRIEBSTECHNIK

Das Winkelgetriebe



Hypoid gearboxes
Type H

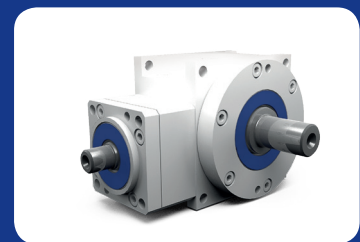

Miniature
bevel gearboxes

Bevel
gearboxes

Hygiene-design
gearboxes

Hypoid
gearboxes

Worm
gearboxes

Gearbox
motors

Servo gearboxes
(precision gearboxes)

Special
gearboxes

ATEX
gearboxes

Gear sets

Service

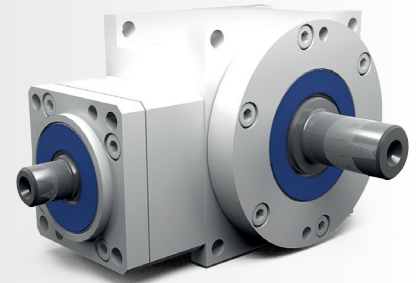

8.1 Type overview

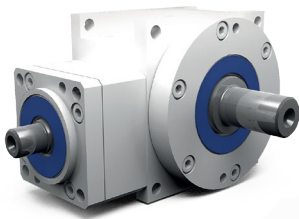

Type H – Hypoid gearboxes

Gear ratios: $i = 3:1$ to $15:1$
Maximum output torque: 1450 Nm
6 gearbox sizes with edge lengths of 090 to 260 mm
Low-backlash construction < 4 angular minutes possible
Housing made of aluminium

8.2 General construction

The axles intersect in the gearbox at the distance A in an angle of 90°.

Gearbox size	090	115	140	170	215	260
A [mm]	9	14	18	23	32	42

The edge length of the housing is reflected in the gearbox size (example: H 090: the housing edge length is 90 mm, with the viewing direction towards the output side of the gearbox). The housings are made of aluminium, the shaft suspension units are made of steel or casting.

8.2.1 Toothing

ATEK hypoid gearboxes have gear sets with high-quality hypoid toothing made of hardened carburised steel. A gear set comprises one pinion shaft (small number of teeth / small diameter) and one bevel gear (large number of teeth / large diameter).

Gear sets with spiral toothing offer the advantage of very favourable engagement factors (high meshing ratio). Therefore they are predestined for usage with high loads. On hypoid gear sets, the axial offset between pinion shaft and gear results in higher sliding motion rates in the tooth contact. This makes it possible to achieve especially great running smoothness and a high transmission accuracy.

8.2.2 Construction types

Due to the modular system, different gearbox construction types can be configured. The construction types vary in

Construction type	consists of:
B0 through E0	1 gear set

Table 8.2.2-1

The variants differ in the type of the shafts, the rotational direction thereof, and the possibility to use a robot flange interface (BOR and COR).

8.2.3 Threaded mounting holes

The sides 1 and 2 of the gearboxes are machined and may be used as mounting surfaces. The flange on side 3 has also threaded mounting holes. On the sides 5 and 6, fastening can be made via through bores.

You have the following available ordering options:

Order code	Threaded mounting holes are in the housing surfaces on the gearbox side	Threaded mounting holes are in the flanges on the gearbox side
0	-	3
9	1, 2	3

Table 8.2.3-1

Please enquire other mounting options.

The standard version of the mounting / fastening has the order code 9.

Example of order code: H 090 12:1 D0 9.1

8.2.4 Installation position

The gearboxes can be used in all installation positions. The recommended installation position is the position in which the shafts are horizontal.

These are the installation positions 1 and 2. The installation position is defined by the gearbox side directed downwards during operation and will be indicated by the corresponding gearbox side. Example of order code for the installation position 1: H 090 12:1 D0 9.1

8.2.5 Shaft designation – allocation to the gearbox sides

The fast-rotating shaft has the speed n_1 and is identified by N_1 . The hypoid pinion is located on this shaft. The slowly rotating shaft has the speed n_2 and is identified by N_2 . The hypoid gear is located on this shaft. The gearbox sides are identified by the numerals 1 to 6. (See Figure 4.3.1-1; Gearbox sides)

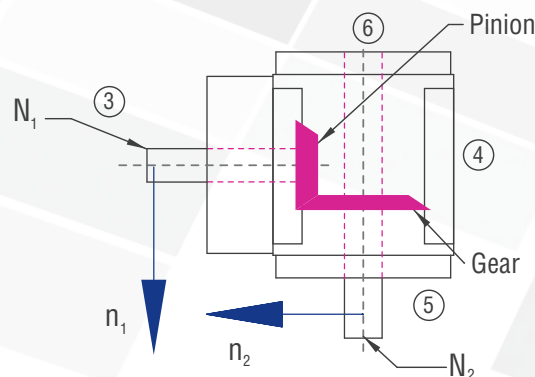

Figure 8.2.5-1; Shaft designations

8.2.6 Preferred direction of rotation

If the clockwise (CW) direction of rotation (viewing direction from shaft end face of the fast-rotating shaft towards the gearbox centre) is selected, a lower noise level is generated.

8.2.7 Efficiency

The achievable efficiency depends on rotational speed, torque, installation position, sealing, and lubricant type. The efficiency is about 95%. The efficiency specified relates to the permissible nominal load and is a guidance value for run-in gearboxes at operating temperature with standard sealing.

8.2.8 Lubrication

The H-series gearboxes have lifetime lubrication.

8.2.9 Vent filter

If venting is required (B1 or C1) the gearboxes will be delivered with a vent filter. The vent bores will be equipped with screw plugs for transport. The vent filter will be enclosed as a separate item and must be mounted in the intended position prior to commissioning. An elbow may be required. Please adhere to the operating instructions!

8.2.10 Low-backlash construction

For low-friction running, the tooth space in the gear set is manufactured larger than the tooth. When the direction of rotation is changed, this results in a rotation angle until the counter-rotating tooth flanks contact each other. This rotation angle is called circumferential backlash.

Circumferential backlash, measuring method

The circumferential backlash is measured after the drive shaft (N_1) has been fixed. A force of around 2% of the nominal torque is applied to the output shaft (N_2) in both rotational directions. A tooth backlash will result between the two final positions. This can be measured as rotation angle and is indicated in minutes of arc [arcmin].

Circumferential backlash, type

Ordering option	Gear set	090 - 115	140 - 260
/0000	Standard	≤ 5 arcmin	≤ 4 arcmin
/S2	Standard	-	-
/S1	Standard	-	-
/S0	Special gear set	≤ 3 arcmin	≤ 2 arcmin

Table 8.2.10-1

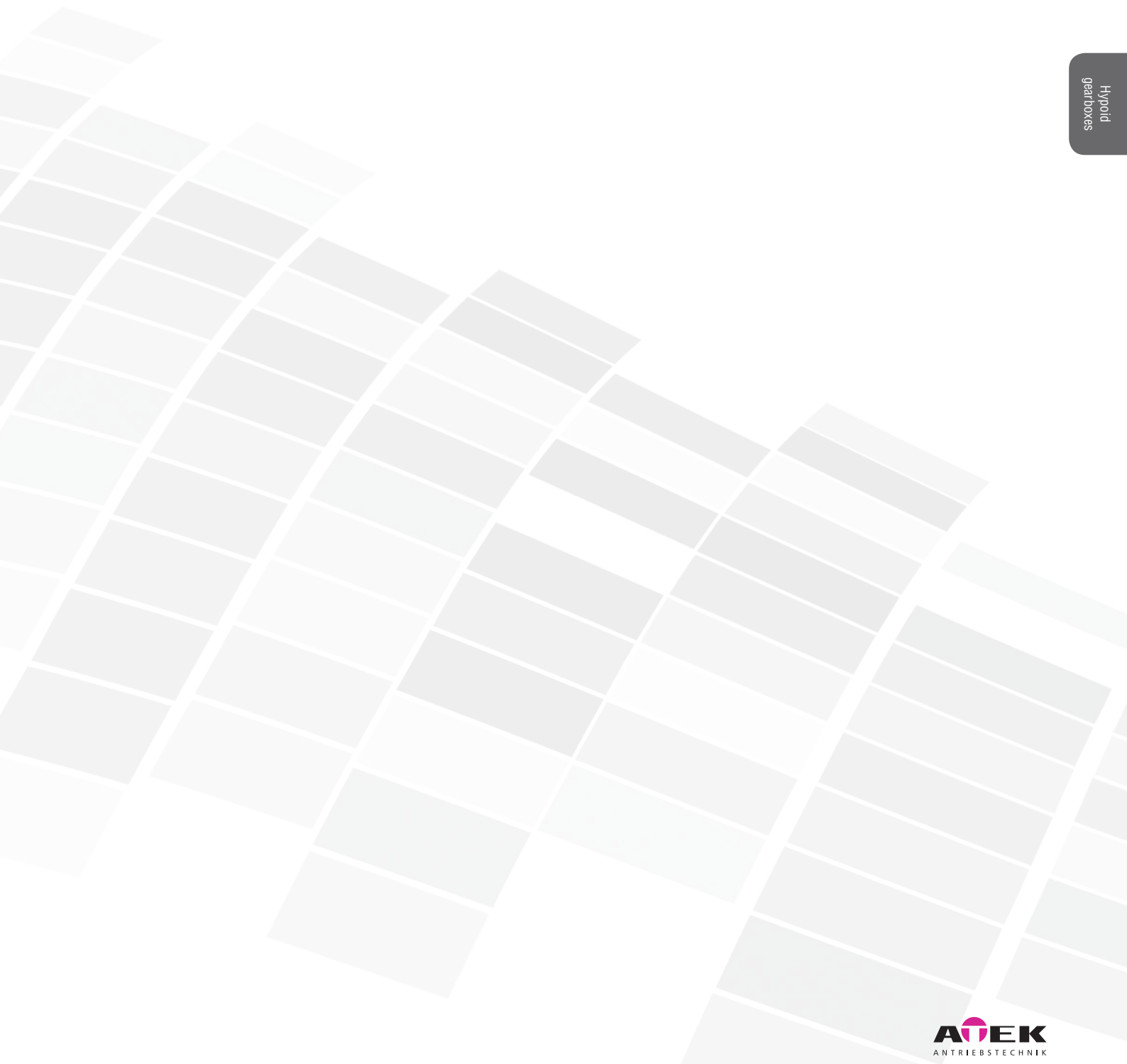

8.3 Type H – Standard hypoid gearboxes

8.3.1 Features

Gear ratios: $i = 3:1$ to $15:1$
 Maximum output torque: 1450 Nm
 6 gearbox sizes with edge lengths of 090 to 260 mm
 Low-backlash construction < 4 angular minutes possible
 Housing made of aluminium

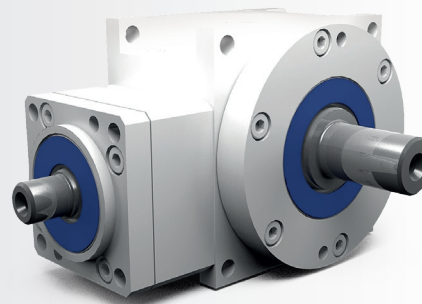

8.3.2 Models

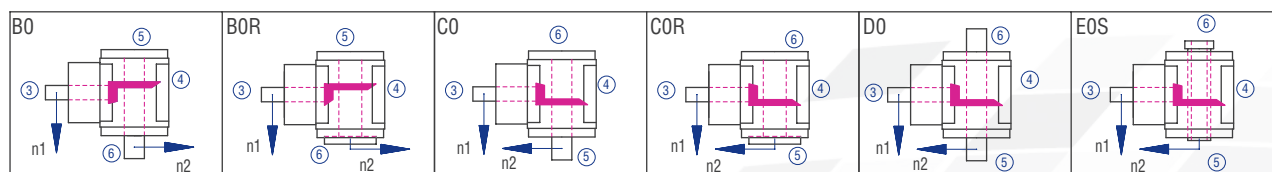

Figure 8.3.2-1; Models

8.3.3 Gearbox sides

The example shows the Model C0

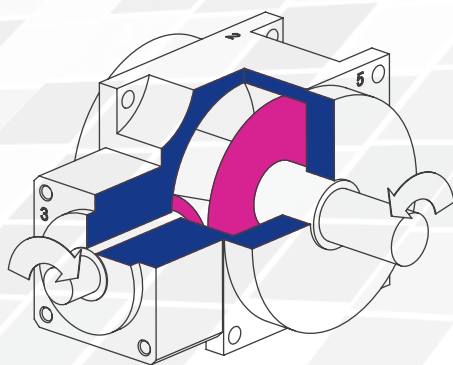

Figure 8.3.3-2; Gearbox sides

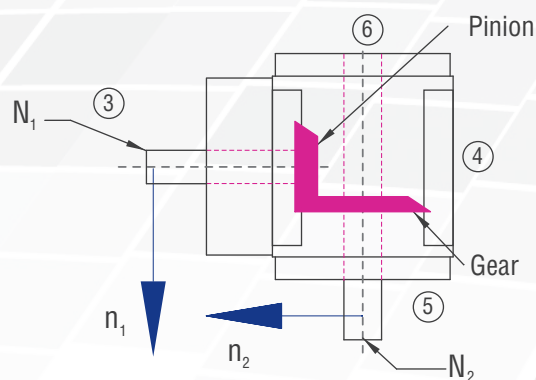

Figure 8.3.3-1; Shaft designations

8.3.4 Order code

The order code reflects the customer specifications. Example:

Type	Size	Gear ratio	Model	Fixing side	Installation position	Speed n_2	Design
H	090	12:1	C0-	1.	1-	200	/S1
Description	Size; Table 8.3.5-1	Table 8.3.5-1	Figure 8.3.2-1; Models	Side on which fixing is made; Table 8.2.3- 1; Figure 4.3.1-1 Gearbox sides	Side directed downwards; Figure 4.3.1-1 Gearbox sides	Slowly rotating shaft	S1 Standard

8.3.5 Overview of performance data

Selection table: gearbox size; gear ratio; rotational speed

size	N ₁ MAX [rpm]	N ₁ [rpm]	3:1			4:1			5:1			6:1			8:1			10:1			12:1			15:1				
			T _{2N} [Nm]	T _{2B} [Nm]	T _{2NOT} [Nm]	T _{2N} [Nm]	T _{2B} [Nm]	T _{2NOT} [Nm]	T _{2N} [Nm]	T _{2B} [Nm]	T _{2NOT} [Nm]	T _{2N} [Nm]	T _{2B} [Nm]	T _{2NOT} [Nm]	T _{2N} [Nm]	T _{2B} [Nm]	T _{2NOT} [Nm]	T _{2N} [Nm]	T _{2B} [Nm]	T _{2NOT} [Nm]	T _{2N} [Nm]	T _{2B} [Nm]	T _{2NOT} [Nm]	T _{2N} [Nm]	T _{2B} [Nm]	T _{2NOT} [Nm]		
090	8000	3900																			25	39	51	25	39	51		
		3200											36	54	72	36	54	72	36	54	72							
		2100	36	54	72	36	54	72	36	54	72																	
115	8000	3300																				51	77	102	51	77	102	
		2700											71	107	143	71	107	143	71	107	143							
		1800	71	107	143	71	107	143	71	107	143																	
140	7000	2800																				97	145	193	97	145	193	
		2200												142	215	286	142	215	286	142	215	286						
		1500	142	215	286	142	215	286	142	215	286																	
170	6000	2300																				182	275	365	182	275	365	
		1800												266	398	528	266	398	528	266	398	528						
		1150	266	398	528	266	398	528	266	398	528																	
215	5000	1600																				512	767	1022	512	767	1022	
		1200												723	1084	1450	723	1084	1450	723	1084	1450						
		700	723	1084	1450	723	1084	1450	723	1084	1450																	
260	4500	1300																				1023	1533	2044	1023	1533	2044	
		1000													1444	2165	2880	1444	2165	2880	1444	2165	2880					
		550	1444	2165	2880	1444	2165	2880	1444	2165	2880																	

Table 8.3.5-1

Hybrid gearboxes

8.3.6 Type H 090 – Standard hypoid gearboxes

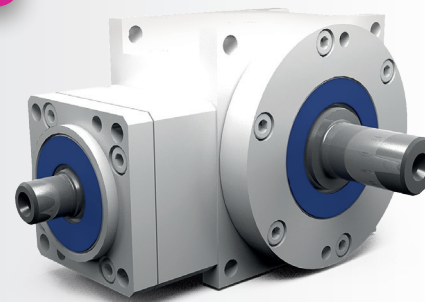

Characteristics

Characteristic	Standard	Option
Toothing	Spiral-toothed, hardened hypoid bevel gears	See chapter 8.2.1
Gear ratio	3:1 to 15:1	
Housing / Flanges	Aluminium / steel or casting	
Threaded mounting holes	On the sides 1, 2 and 3	See chapter 8.2.3
Shaft	Material 1 C45, shaft ends greased Fit with ISO 6 tolerance	See chapter 4.6.2
Hollow shaft	Material 1 C45, shafts greased Fit with ISO 6 tolerance	See chapter 4.6.3
Radial shaft seal ring	NBR, form A	See chapter 4.8
Ambient temperature	-10°C to +90°C. The values of the performance tables are valid for +20°C	See chapter 4.9.3
Circumferential backlash	< 5 arcmin	See chapter 8.2.10
Protection class	IP 64	See chapter 4.5
Corrosion protection	Prime coat; layer thickness >40 µm	See chapter 4.4
Bearing life L10h	more than 30,000h in S5 operation	See chapter 4.9.1
Oil change intervals	Not required if the oil temperature is kept < 90°C. The lifetime of the bearings can be increased by the factor 1.5 if the oil is changed after the first 500 service hours and then every 5000 service hours.	See chapter 8.2.8
Lubricants	Synthetic lubricants	See chapter 8.2.8

Performance data

N ₁ [rpm]	N ₁ MAX [rpm]	3:1			4:1			5:1			6:1			8:1			10:1			12:1			15:1		
		T _{2N} [Nm]	T _{2B} [Nm]	T _{2NOT} [Nm]	T _{2N} [Nm]	T _{2B} [Nm]	T _{2NOT} [Nm]	T _{2N} [Nm]	T _{2B} [Nm]	T _{2NOT} [Nm]	T _{2N} [Nm]	T _{2B} [Nm]	T _{2NOT} [Nm]	T _{2N} [Nm]	T _{2B} [Nm]	T _{2NOT} [Nm]	T _{2N} [Nm]	T _{2B} [Nm]	T _{2NOT} [Nm]	T _{2N} [Nm]	T _{2B} [Nm]	T _{2NOT} [Nm]	T _{2N} [Nm]	T _{2B} [Nm]	T _{2NOT} [Nm]
3900	8000	0	0	0	0	0	0	0	0	0	0	0	0	0	0	0	0	0	0	25	39	51	25	39	51
3200	8000	0	0	0	0	0	0	0	0	0	36	54	72	36	54	72	36	54	72	0	0	0	0	0	0
2100	8000	36	54	72	36	54	72	36	54	72	0	0	0	0	0	0	0	0	0	0	0	0	0	0	0

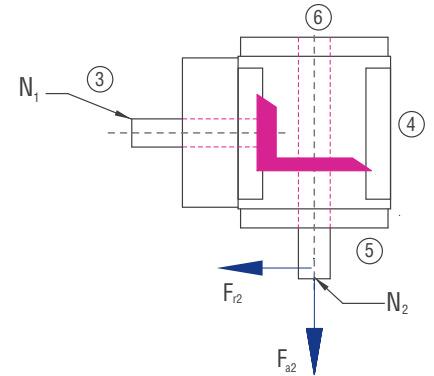

Permissible radial force F_{r2} and axial force F_{a2} on shaft N_2

3:1		4:1		5:1		6:1		8:1		10:1		12:1		15:1	
F_{r2} [N]	F_{a2} [N]	F_{r2} [N]	F_{a2} [N]	F_{r2} [N]	F_{a2} [N]	F_{r2} [N]	F_{a2} [N]	F_{r2} [N]	F_{a2} [N]	F_{r2} [N]	F_{a2} [N]	F_{r2} [N]	F_{a2} [N]	F_{r2} [N]	F_{a2} [N]
3300	1650	3300	1650	3300	1650	3300	1650	3300	1650	3300	1650	3300	1650	3300	1650

Gearbox inertia moments/mass

Inertia moment J_1 related to the fast-rotating shaft (N_1)

Inertia moment [kgcm ²]								Mass ca. [kg]
3:1	4:1	5:1	6:1	8:1	10:1	12:1	15:1	
0,3900	0,3000	0,2300	0,2200	0,1700	0,1500	0,1400	0,1300	3.5

The mass of the gearbox may deviate depending on the type and the gear ratio.

8.3.6 Type H 090 – Standard hypoid gearboxes

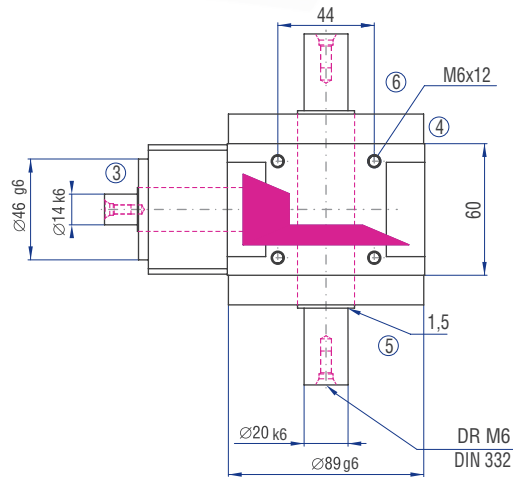
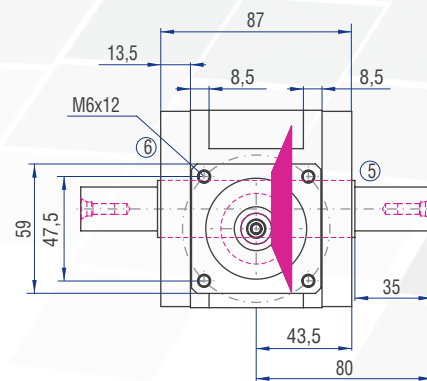
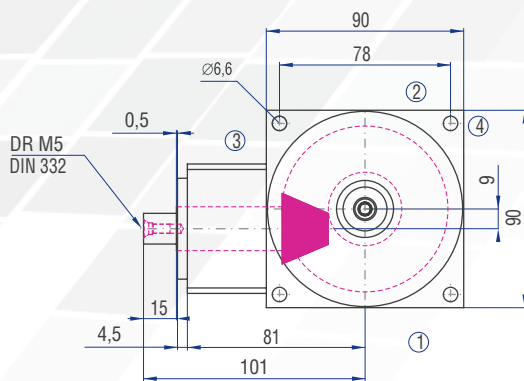
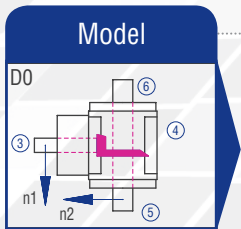
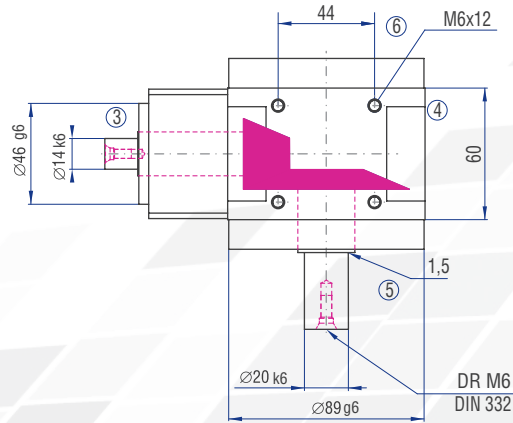
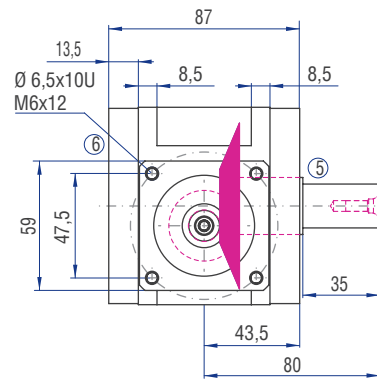
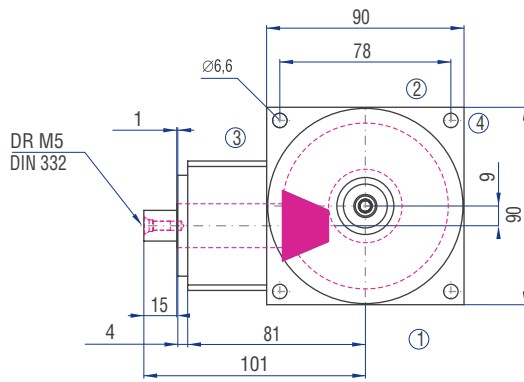
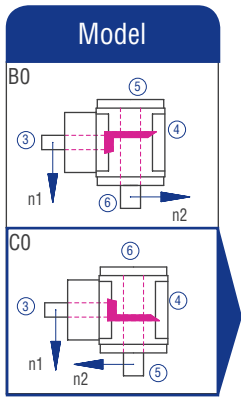

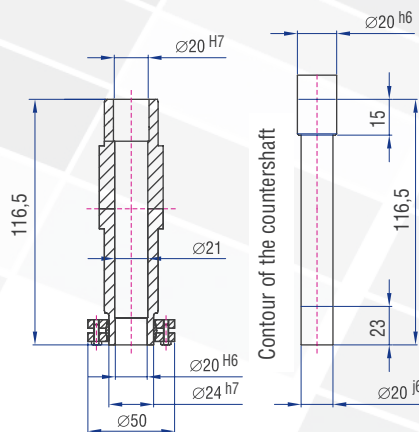
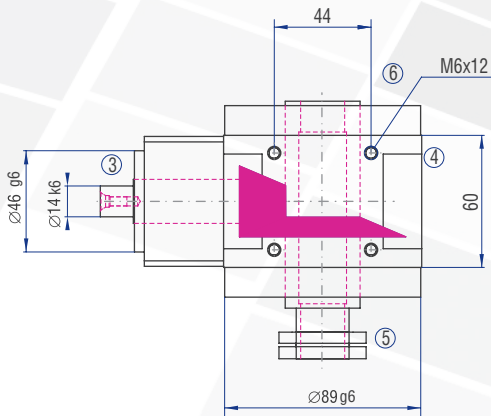
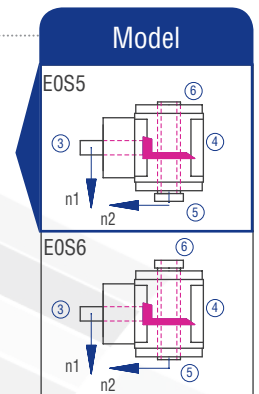
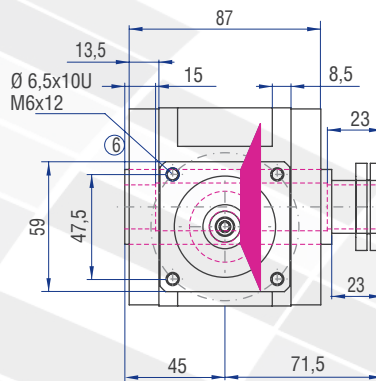
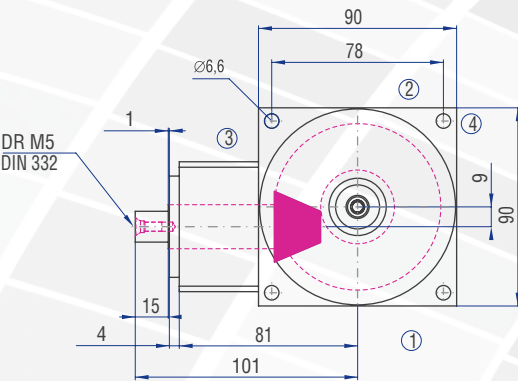
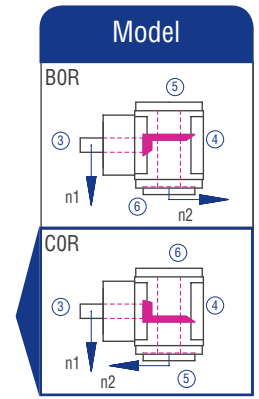
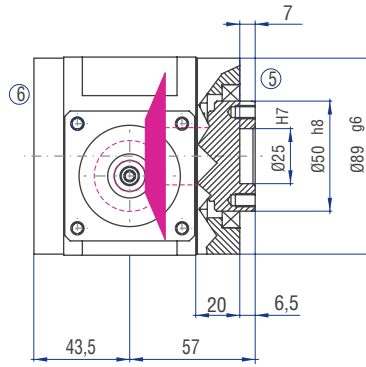
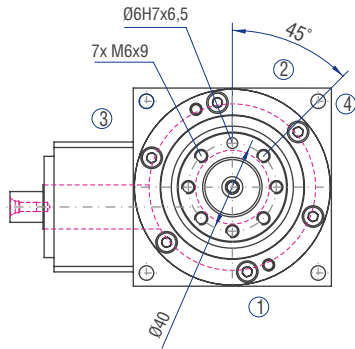

8.3.7 Type H 115 – Standard hypoid gearboxes

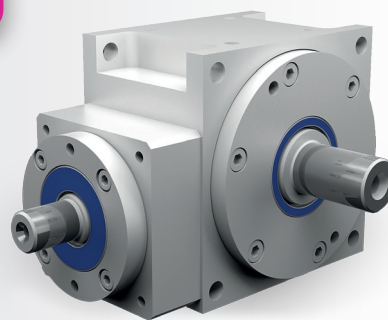

Characteristics

Characteristic	Standard	Option
Toothing	Spiral-toothed, hardened hypoid bevel gears	See chapter 8.2.1
Gear ratio	3:1 to 15:1	
Housing / Flanges	Aluminium / steel or casting	
Threaded mounting holes	On the sides 1, 2 and 3	See chapter 8.2.3
Shaft	Material 1 C45, shaft ends greased Fit with ISO 6 tolerance	See chapter 4.6.2
Hollow shaft	Material 1 C45, shafts greased Fit with ISO 6 tolerance	See chapter 4.6.3
Radial shaft seal ring	NBR, form A	See chapter 4.8
Ambient temperature	-10°C to +90°C. The values of the performance tables are valid for +20°C	See chapter 4.9.3
Circumferential backlash	< 5 arcmin	See chapter 8.2.10
Protection class	IP 64	See chapter 4.5
Corrosion protection	Prime coat; layer thickness >40 µm	See chapter 4.4
Bearing life L10h	more than 30,000h in S5 operation	See chapter 4.9.1
Oil change intervals	Not required if the oil temperature is kept < 90°C. The lifetime of the bearings can be increased by the factor 1.5 if the oil is changed after the first 500 service hours and then every 5000 service hours.	See chapter 8.2.8
Lubricants	Synthetic lubricants	See chapter 8.2.8

Performance data

N ₁ [rpm]	N ₁ MAX [rpm]	3:1			4:1			5:1			6:1			8:1			10:1			12:1			15:1		
		T _{2N} [Nm]	T _{2B} [Nm]	T _{2NOT} [Nm]	T _{2N} [Nm]	T _{2B} [Nm]	T _{2NOT} [Nm]	T _{2N} [Nm]	T _{2B} [Nm]	T _{2NOT} [Nm]	T _{2N} [Nm]	T _{2B} [Nm]	T _{2NOT} [Nm]	T _{2N} [Nm]	T _{2B} [Nm]	T _{2NOT} [Nm]	T _{2N} [Nm]	T _{2B} [Nm]	T _{2NOT} [Nm]	T _{2N} [Nm]	T _{2B} [Nm]	T _{2NOT} [Nm]	T _{2N} [Nm]	T _{2B} [Nm]	T _{2NOT} [Nm]
3300	8000	0	0	0	0	0	0	0	0	0	0	0	0	0	0	0	0	0	0	51	77	102	51	77	102
2700	8000	0	0	0	0	0	0	0	0	0	71	107	143	71	107	143	71	107	143	0	0	0	0	0	0
1800	8000	71	107	143	71	107	143	71	107	143	0	0	0	0	0	0	0	0	0	0	0	0	0	0	0

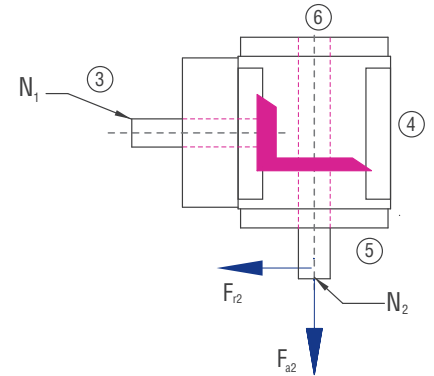

Permissible radial force F_{r2} and axial force F_{a2} on shaft N_2

3:1		4:1		5:1		6:1		8:1		10:1		12:1		15:1	
F_{r2} [N]	F_{a2} [N]	F_{r2} [N]	F_{a2} [N]	F_{r2} [N]	F_{a2} [N]	F_{r2} [N]	F_{a2} [N]	F_{r2} [N]	F_{a2} [N]	F_{r2} [N]	F_{a2} [N]	F_{r2} [N]	F_{a2} [N]	F_{r2} [N]	F_{a2} [N]
4900	2450	4900	2450	4900	2450	4900	2450	4900	2450	4900	2450	4900	2450	4900	2450

Gearbox inertia moments/mass

Inertia moment J_1 related to the fast-rotating shaft (N_1)

Inertia moment [kgcm ²]								Mass ca. [kg]
3:1	4:1	5:1	6:1	8:1	10:1	12:1	15:1	
0,9800	0,7300	0,5800	0,5200	0,4300	0,3800	0,3600	0,3400	5.5

The mass of the gearbox may deviate depending on the type and the gear ratio.

8.3.7 Type H 115 – Standard hypoid gearboxes

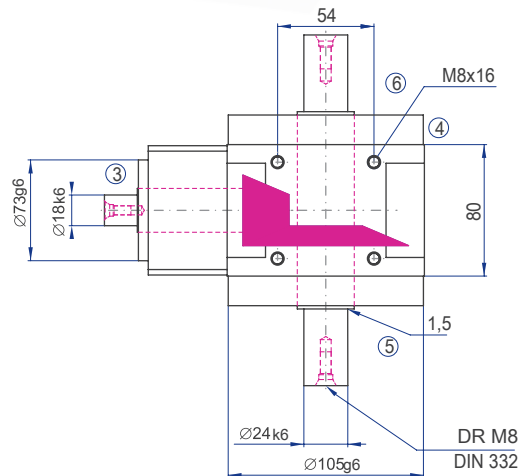
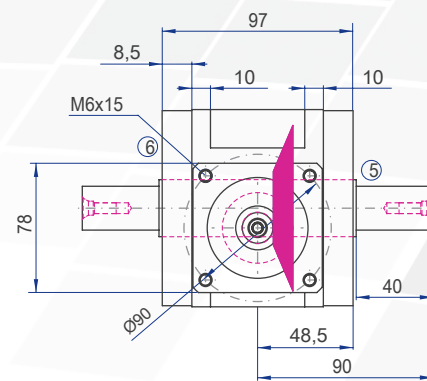
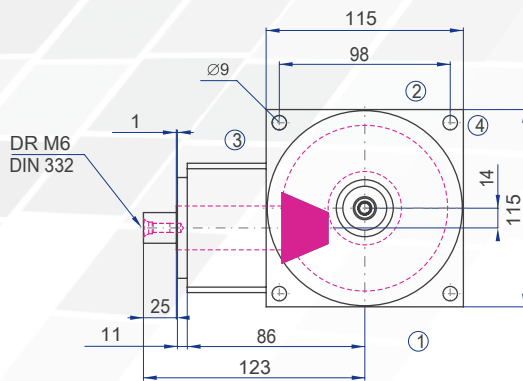
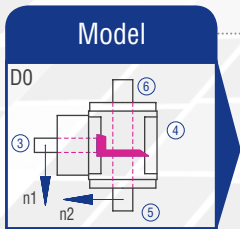
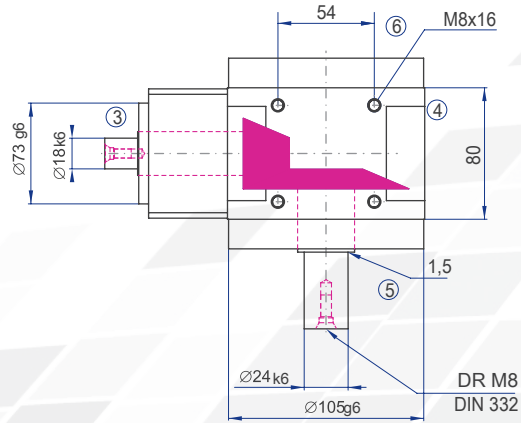
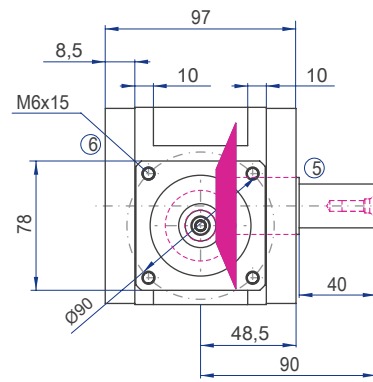
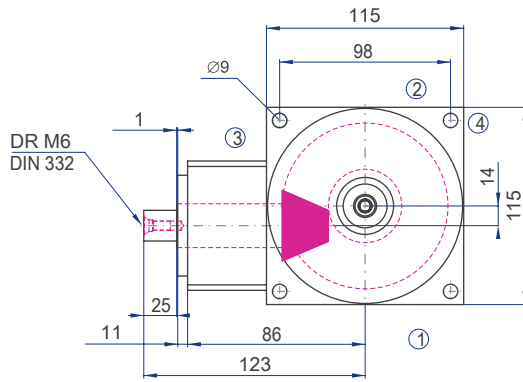
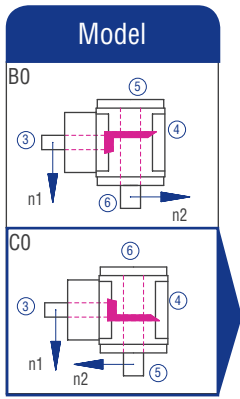

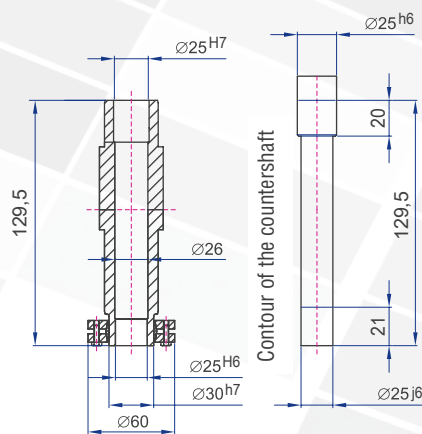
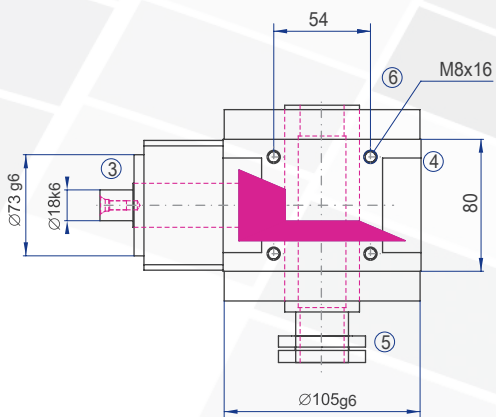
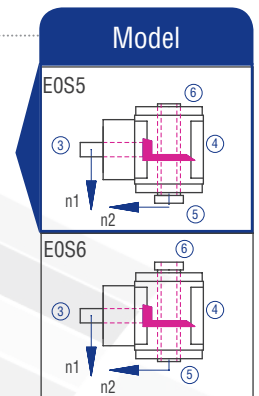
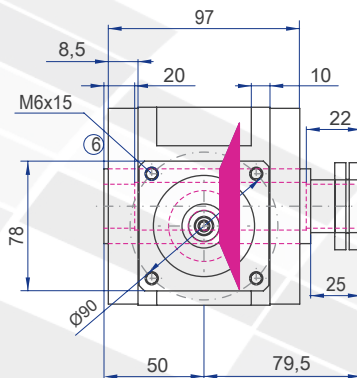
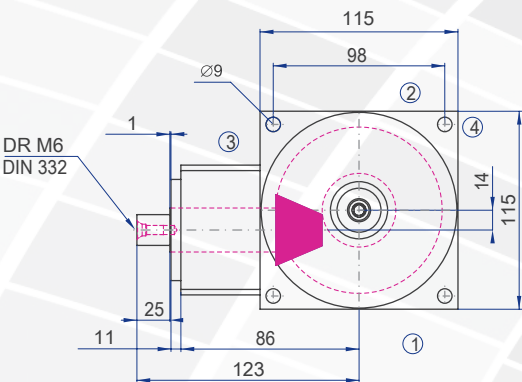
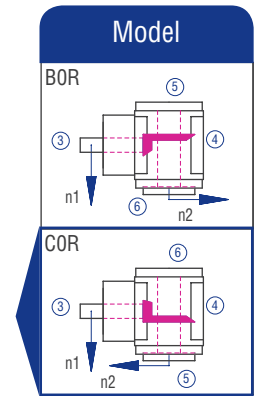
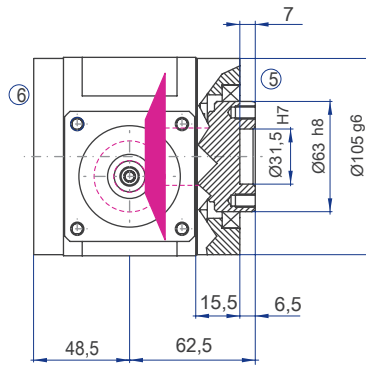
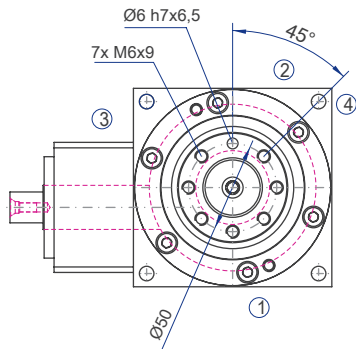

8.3.8 Type H 140 – Standard hypoid gearboxes

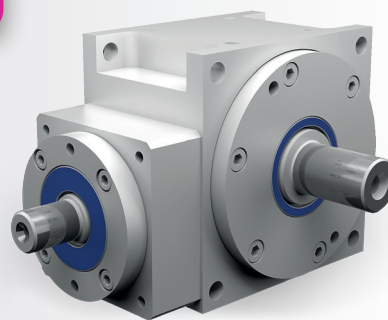

Characteristics

Characteristic	Standard	Option
Toothing	Spiral-toothed, hardened hypoid bevel gears	See chapter 8.2.1
Gear ratio	3:1 to 15:1	
Housing / Flanges	Aluminium / steel or casting	
Threaded mounting holes	On the sides 1, 2 and 3	See chapter 8.2.3
Shaft	Material 1 C45, shaft ends greased Fit with ISO 6 tolerance	See chapter 4.6.2
Hollow shaft	Material 1 C45, shafts greased Fit with ISO 6 tolerance	See chapter 4.6.3
Radial shaft seal ring	NBR, form A	See chapter 4.8
Ambient temperature	-10°C to +90°C. The values of the performance tables are valid for +20°C	See chapter 4.9.3
Circumferential backlash	< 4 arcmin	See chapter 8.2.10
Protection class	IP 64	See chapter 4.5
Corrosion protection	Prime coat; layer thickness >40 µm	See chapter 4.4
Bearing life L10h	more than 30,000h in S5 operation	See chapter 4.9.1
Oil change intervals	Not required if the oil temperature is kept < 90°C. The lifetime of the bearings can be increased by the factor 1.5 if the oil is changed after the first 500 service hours and then every 5000 service hours.	See chapter 8.2.8
Lubricants	Synthetic lubricants	See chapter 8.2.8

Performance data

N ₁ [rpm]	N ₁ MAX [rpm]	3:1			4:1			5:1			6:1			8:1			10:1			12:1			15:1		
		T _{2N} [Nm]	T _{2B} [Nm]	T _{2NOT} [Nm]	T _{2N} [Nm]	T _{2B} [Nm]	T _{2NOT} [Nm]	T _{2N} [Nm]	T _{2B} [Nm]	T _{2NOT} [Nm]	T _{2N} [Nm]	T _{2B} [Nm]	T _{2NOT} [Nm]	T _{2N} [Nm]	T _{2B} [Nm]	T _{2NOT} [Nm]	T _{2N} [Nm]	T _{2B} [Nm]	T _{2NOT} [Nm]	T _{2N} [Nm]	T _{2B} [Nm]	T _{2NOT} [Nm]	T _{2N} [Nm]	T _{2B} [Nm]	T _{2NOT} [Nm]
2800	7000	0	0	0	0	0	0	0	0	0	0	0	0	0	0	0	0	0	0	97	145	193	97	145	193
2200	7000	0	0	0	0	0	0	0	0	0	142	215	286	142	215	286	142	215	286	0	0	0	0	0	0
1500	7000	142	215	286	142	215	286	142	215	286	0	0	0	0	0	0	0	0	0	0	0	0	0	0	0

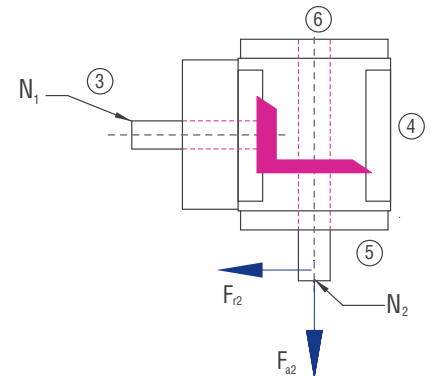

Permissible radial force F_{r2} and axial force F_{a2} on shaft N_2

3:1		4:1		5:1		6:1		8:1		10:1		12:1		15:1	
F_{r2} [N]	F_{a2} [N]	F_{r2} [N]	F_{a2} [N]	F_{r2} [N]	F_{a2} [N]	F_{r2} [N]	F_{a2} [N]	F_{r2} [N]	F_{a2} [N]	F_{r2} [N]	F_{a2} [N]	F_{r2} [N]	F_{a2} [N]	F_{r2} [N]	F_{a2} [N]
7200	3600	7200	3600	7200	3600	7200	3600	7200	3600	7200	3600	7200	3600	7200	3600

Gearbox inertia moments/mass

Inertia moment J_1 related to the fast-rotating shaft (N_1)

Inertia moment [kgcm ²]								Mass ca. [kg]
3:1	4:1	5:1	6:1	8:1	10:1	12:1	15:1	
2,4200	1,7700	1,4100	1,4100	1,1200	1,0000	0,8800	0,8100	9.5

The mass of the gearbox may deviate depending on the type and the gear ratio.

8.3.8 Type H 140 – Standard hypoid gearboxes

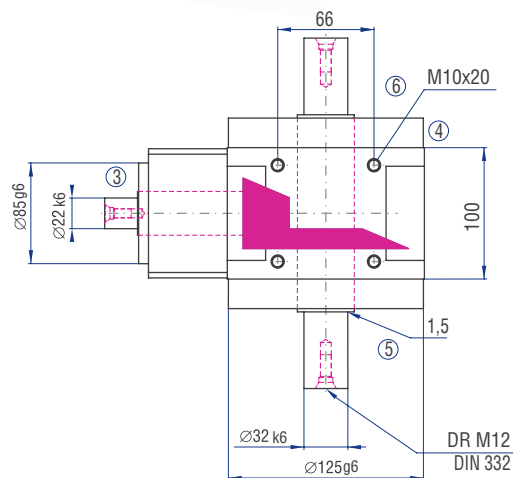
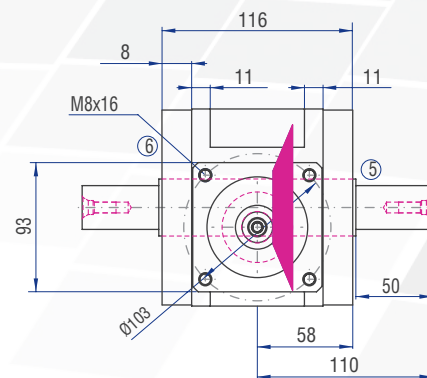
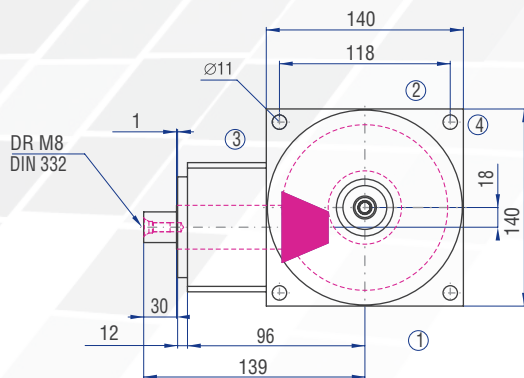
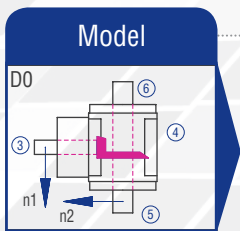
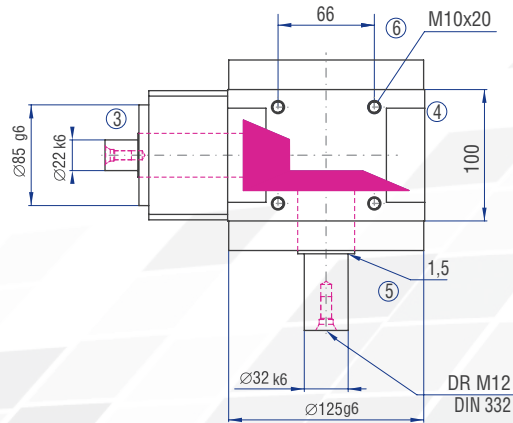
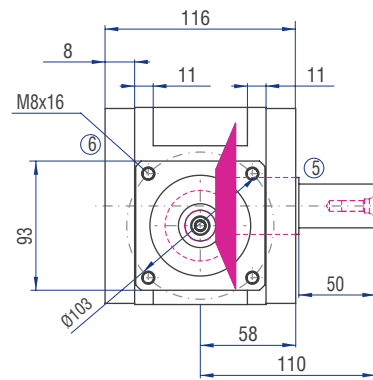
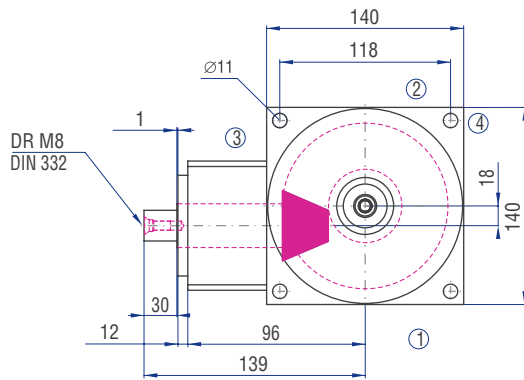
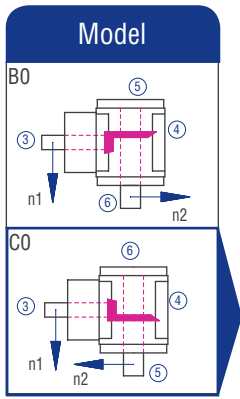

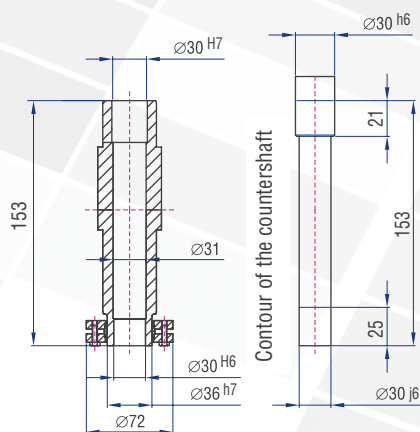
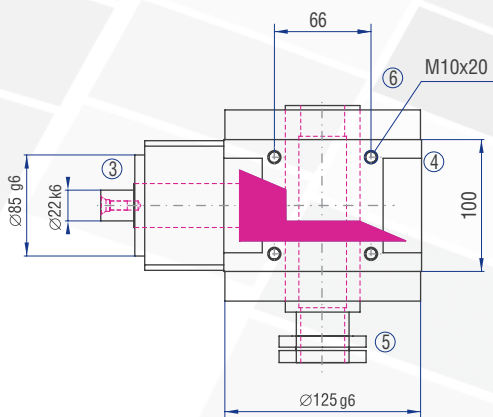
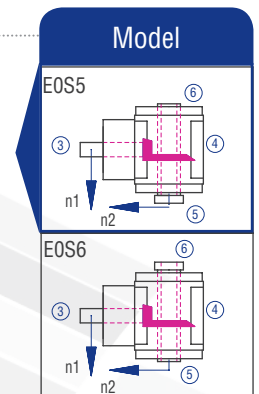
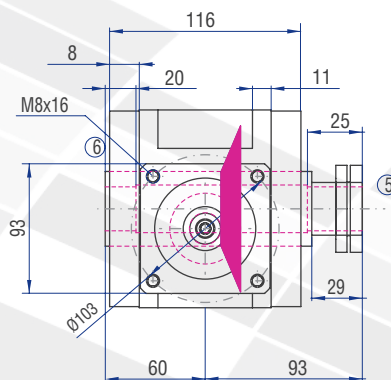
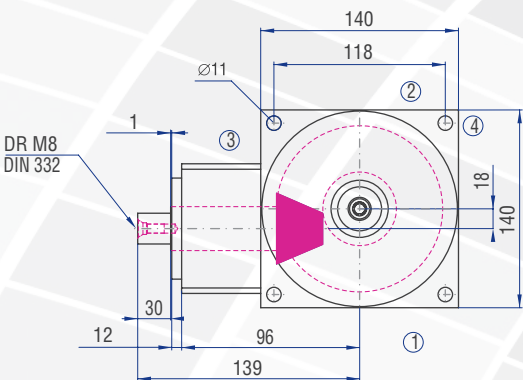
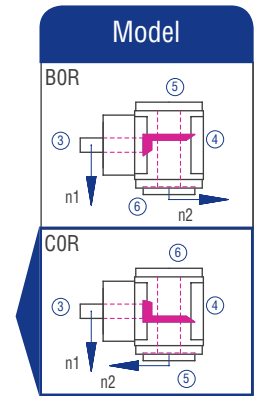
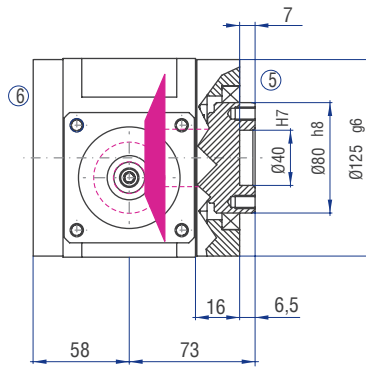
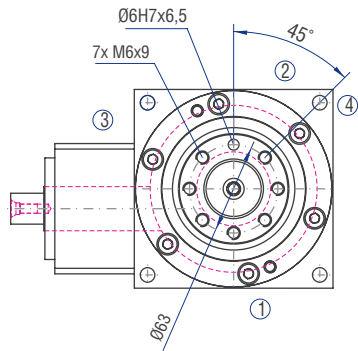

Contour of the countershaft

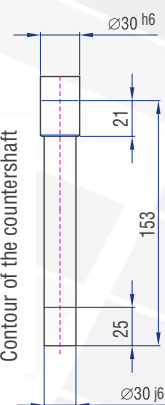

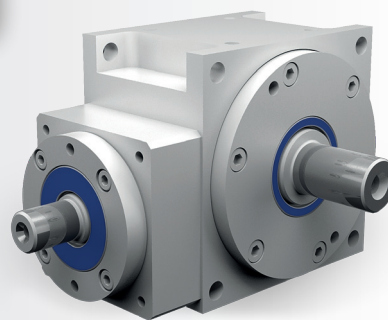

Characteristics

Characteristic	Standard	Option
Toothing	Spiral-toothed, hardened hypoid bevel gears	See chapter 8.2.1
Gear ratio	3:1 to 15:1	
Housing / Flanges	Aluminium / steel or casting	
Threaded mounting holes	On the sides 1, 2 and 3	See chapter 8.2.3
Shaft	Material 1 C45, shaft ends greased Fit with ISO 6 tolerance	See chapter 4.6.2
Hollow shaft	Material 1 C45, shafts greased Fit with ISO 6 tolerance	See chapter 4.6.3
Radial shaft seal ring	NBR, form A	See chapter 4.8
Ambient temperature	-10°C to +90°C. The values of the performance tables are valid for +20°C	See chapter 4.9.3
Circumferential backlash	< 4 arcmin	See chapter 8.2.10
Protection class	IP 64	See chapter 4.5
Corrosion protection	Prime coat; layer thickness >40 µm	See chapter 4.4
Bearing life L10h	more than 30,000h in S5 operation	See chapter 4.9.1
Oil change intervals	Not required if the oil temperature is kept < 90°C. The lifetime of the bearings can be increased by the factor 1.5 if the oil is changed after the first 500 service hours and then every 5000 service hours.	See chapter 8.2.8
Lubricants	Synthetic lubricants	See chapter 8.2.8

Performance data

N ₁ [rpm]	N ₁ MAX [rpm]	3:1			4:1			5:1			6:1			8:1			10:1			12:1			15:1		
		T _{2N} [Nm]	T _{2B} [Nm]	T _{2NOT} [Nm]	T _{2N} [Nm]	T _{2B} [Nm]	T _{2NOT} [Nm]	T _{2N} [Nm]	T _{2B} [Nm]	T _{2NOT} [Nm]	T _{2N} [Nm]	T _{2B} [Nm]	T _{2NOT} [Nm]	T _{2N} [Nm]	T _{2B} [Nm]	T _{2NOT} [Nm]	T _{2N} [Nm]	T _{2B} [Nm]	T _{2NOT} [Nm]	T _{2N} [Nm]	T _{2B} [Nm]	T _{2NOT} [Nm]	T _{2N} [Nm]	T _{2B} [Nm]	T _{2NOT} [Nm]
2300	6000	0	0	0	0	0	0	0	0	0	0	0	0	0	0	0	0	0	0	182	275	365	182	275	365
1800	6000	0	0	0	0	0	0	0	0	0	266	398	528	266	398	528	266	398	528	0	0	0	0	0	0
1150	6000	266	398	528	266	398	528	266	398	528	0	0	0	0	0	0	0	0	0	0	0	0	0	0	0

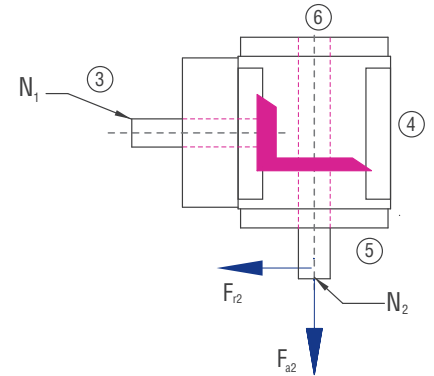

Permissible radial force F_{r2} and axial force F_{a2} on shaft N_2

3:1		4:1		5:1		6:1		8:1		10:1		12:1		15:1	
F_{r2} [N]	F_{a2} [N]	F_{r2} [N]	F_{a2} [N]	F_{r2} [N]	F_{a2} [N]	F_{r2} [N]	F_{a2} [N]	F_{r2} [N]	F_{a2} [N]	F_{r2} [N]	F_{a2} [N]	F_{r2} [N]	F_{a2} [N]	F_{r2} [N]	F_{a2} [N]
10000	5000	10000	5000	10000	5000	10000	5000	10000	5000	10000	5000	10000	5000	10000	5000

Gearbox inertia moments/mass

Inertia moment J_1 related to the fast-rotating shaft (N_1)

Inertia moment [kgcm ²]								Mass ca. [kg]
3:1	4:1	5:1	6:1	8:1	10:1	12:1	15:1	
7,1200	5,0900	4,0000	3,6500	2,8500	2,4600	2,2500	2,0700	15.5

The mass of the gearbox may deviate depending on the type and the gear ratio.

Hybrid
gearboxes

8.3.9 Type H 170 – Standard hypoid gearboxes

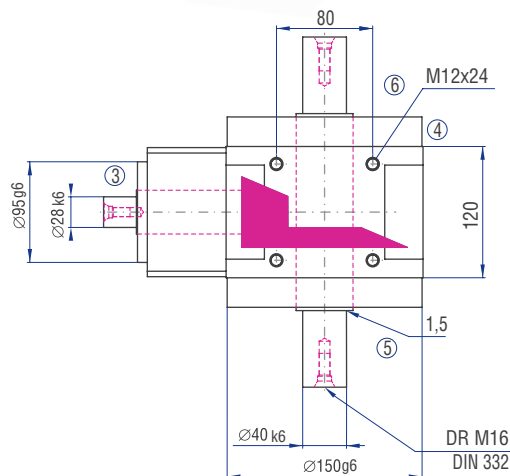
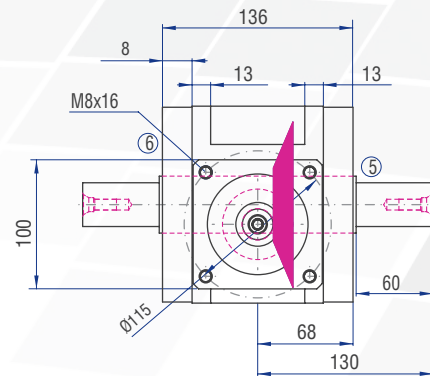
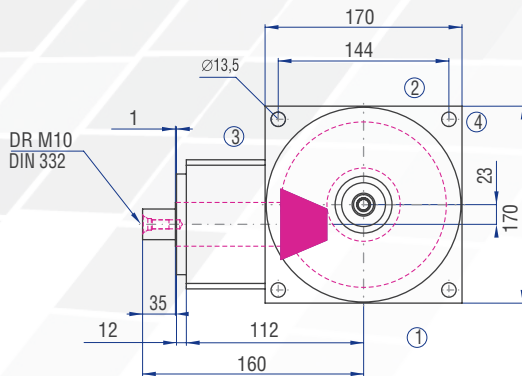
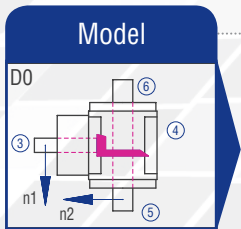
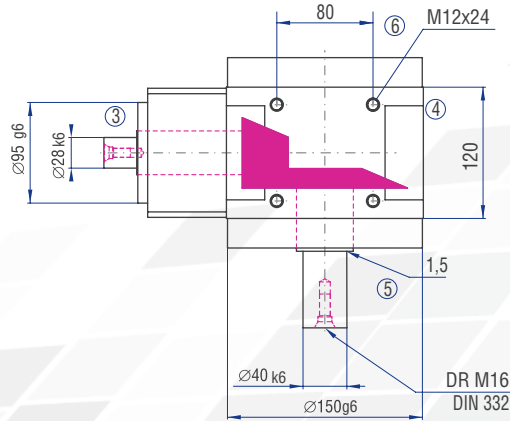
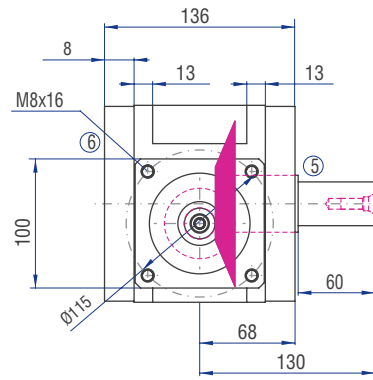
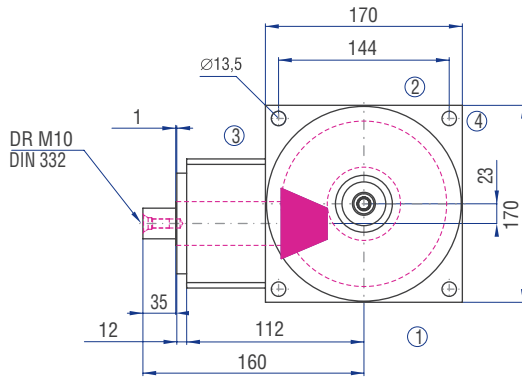
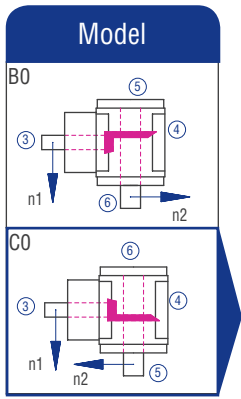

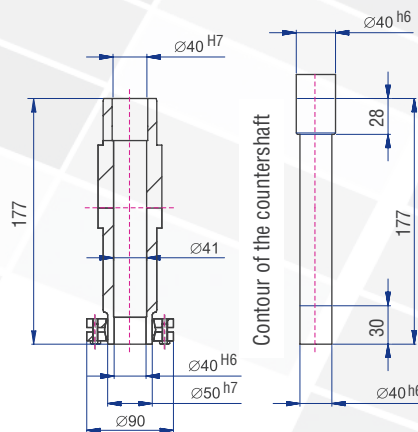
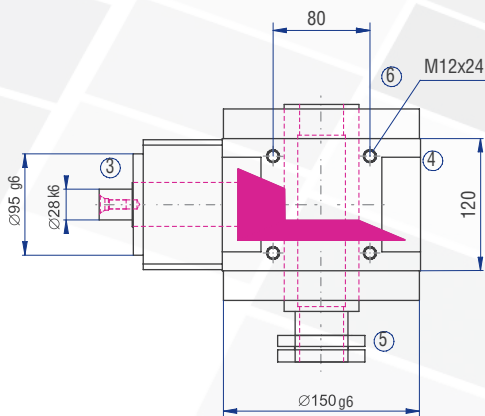
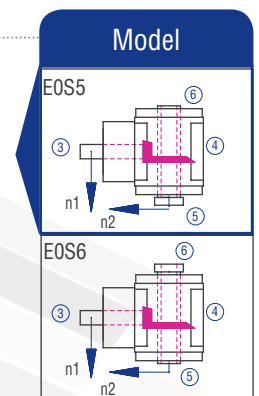
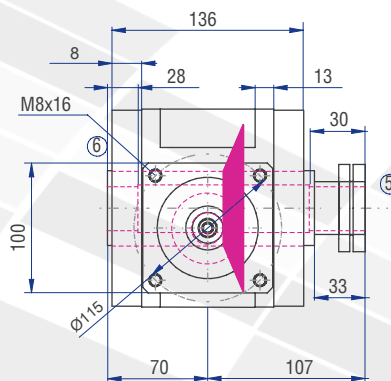
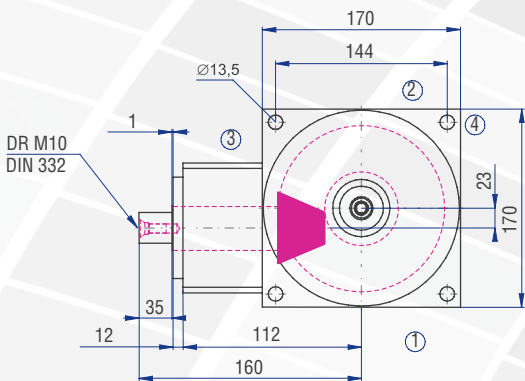
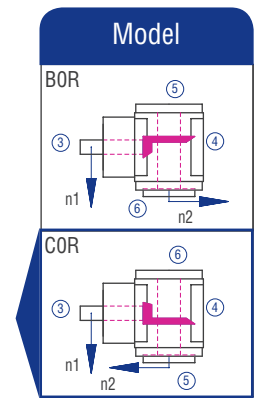
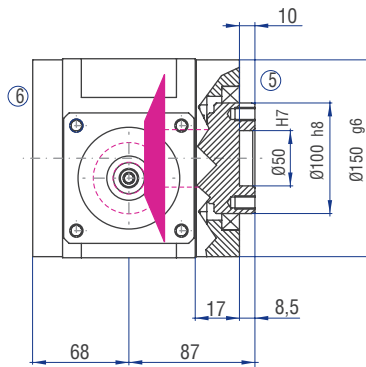
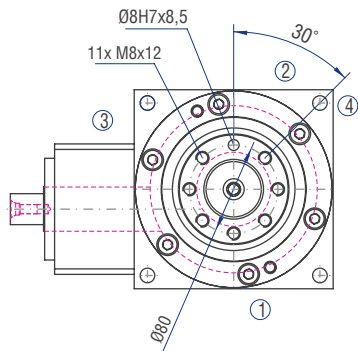

8.3.10 Type H 215 – Standard hypoid gearboxes

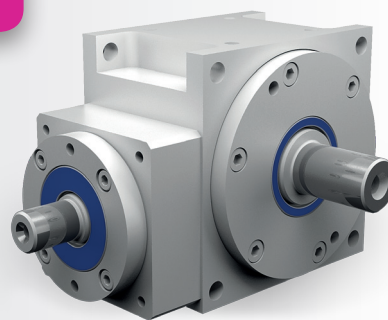

Characteristics

Characteristic	Standard	Option
Toothing	Spiral-toothed, hardened hypoid bevel gears	See chapter 8.2.1
Gear ratio	3:1 to 15:1	
Housing / Flanges	Aluminium / steel or casting	
Threaded mounting holes	On the sides 1, 2 and 3	See chapter 8.2.3
Shaft	Material 1 C45, shaft ends greased Fit with ISO 6 tolerance	See chapter 4.6.2
Hollow shaft	Material 1 C45, shafts greased Fit with ISO 6 tolerance	See chapter 4.6.3
Radial shaft seal ring	NBR, form A	See chapter 4.8
Ambient temperature	-10°C to +90°C. The values of the performance tables are valid for +20°C	See chapter 4.9.3
Circumferential backlash	< 4 arcmin	See chapter 8.2.10
Protection class	IP 64	See chapter 4.5
Corrosion protection	Prime coat; layer thickness >40 µm	See chapter 4.4
Bearing life L10h	more than 30,000h in S5 operation	See chapter 4.9.1
Oil change intervals	Not required if the oil temperature is kept < 90°C. The lifetime of the bearings can be increased by the factor 1.5 if the oil is changed after the first 500 service hours and then every 5000 service hours.	See chapter 8.2.8
Lubricants	Synthetic lubricants	See chapter 8.2.8

Performance data

N ₁ [rpm]	N ₁ MAX [rpm]	3:1			4:1			5:1			6:1			8:1			10:1			12:1			15:1		
		T _{2N} [Nm]	T _{2B} [Nm]	T _{2NOT} [Nm]	T _{2N} [Nm]	T _{2B} [Nm]	T _{2NOT} [Nm]	T _{2N} [Nm]	T _{2B} [Nm]	T _{2NOT} [Nm]	T _{2N} [Nm]	T _{2B} [Nm]	T _{2NOT} [Nm]	T _{2N} [Nm]	T _{2B} [Nm]	T _{2NOT} [Nm]	T _{2N} [Nm]	T _{2B} [Nm]	T _{2NOT} [Nm]	T _{2N} [Nm]	T _{2B} [Nm]	T _{2NOT} [Nm]	T _{2N} [Nm]	T _{2B} [Nm]	T _{2NOT} [Nm]
1600	5000	0	0	0	0	0	0	0	0	0	0	0	0	0	0	0	0	0	0	512	767	1022	512	767	1022
1200	5000	0	0	0	0	0	0	0	0	0	723	1084	1450	723	1084	1450	723	1084	1450	0	0	0	0	0	0
700	5000	723	1084	1450	723	1084	1450	723	1084	1450	0	0	0	0	0	0	0	0	0	0	0	0	0	0	0

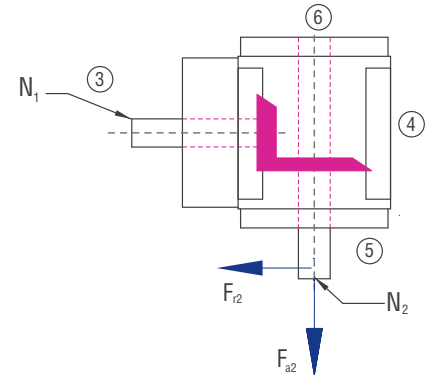

Permissible radial force F_{r2} and axial force F_{a2} on shaft N_2

3:1		4:1		5:1		6:1		8:1		10:1		12:1		15:1	
F_{r2} [N]	F_{a2} [N]	F_{r2} [N]	F_{a2} [N]	F_{r2} [N]	F_{a2} [N]	F_{r2} [N]	F_{a2} [N]	F_{r2} [N]	F_{a2} [N]	F_{r2} [N]	F_{a2} [N]	F_{r2} [N]	F_{a2} [N]	F_{r2} [N]	F_{a2} [N]
15000	7500	15000	7500	15000	7500	15000	7500	15000	7500	15000	7500	15000	7500	15000	7500

Gearbox inertia moments/mass

Inertia moment J_1 related to the fast-rotating shaft (N_1)

Inertia moment [kgcm ²]								Mass ca. [kg]
3:1	4:1	5:1	6:1	8:1	10:1	12:1	15:1	
26,9600	17,4400	13,5300	12,2500	8,9500	7,3800	6,4700	5,7600	32.5

The mass of the gearbox may deviate depending on the type and the gear ratio.

8.3.10 Type H 215 – Standard hypoid gearboxes

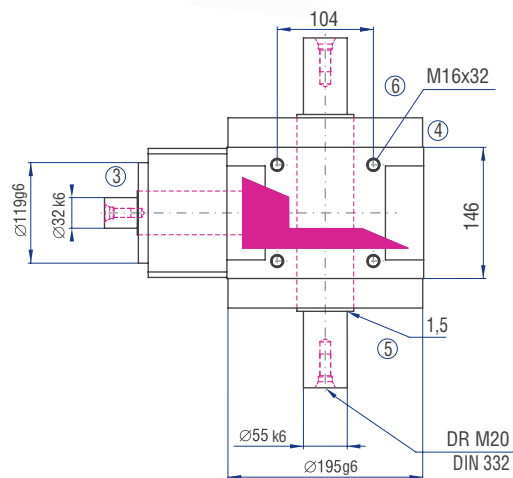
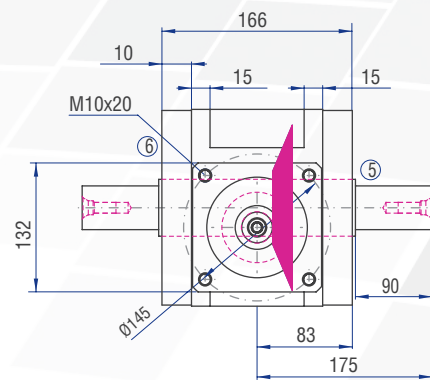
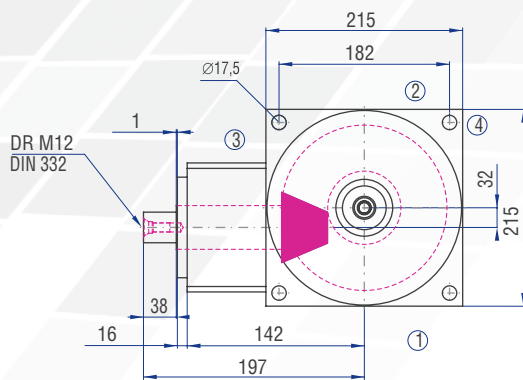
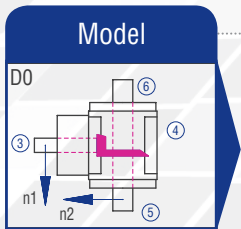
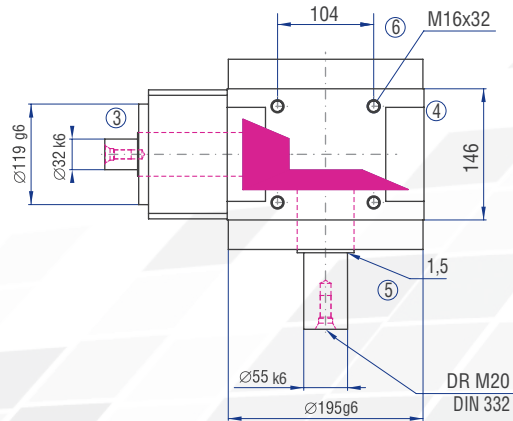
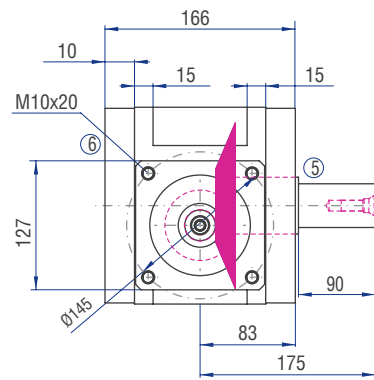
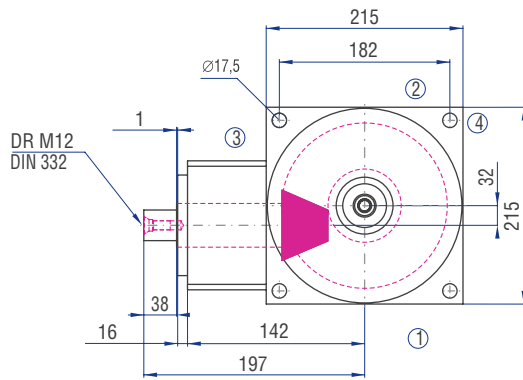
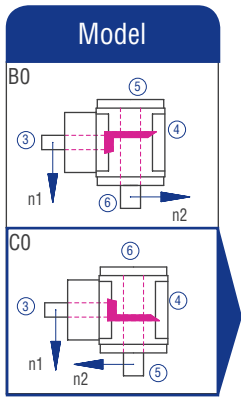

The dimensions of the Models not shown can be figured by mirroring available dimensions.

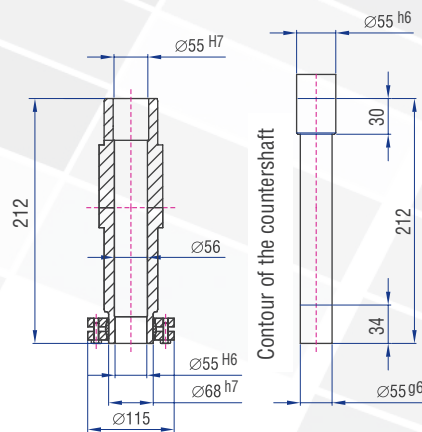
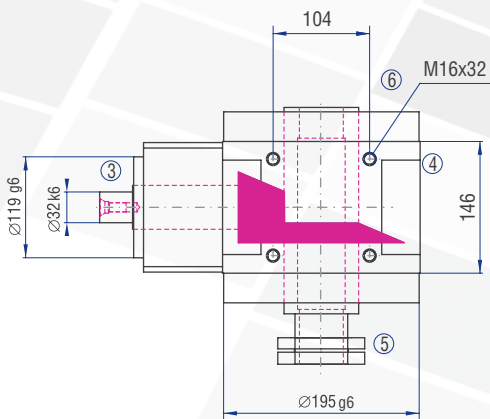
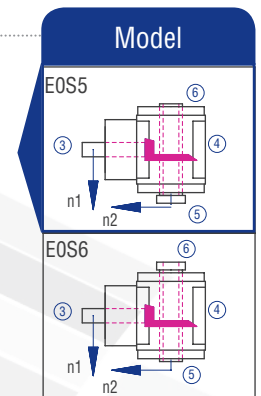
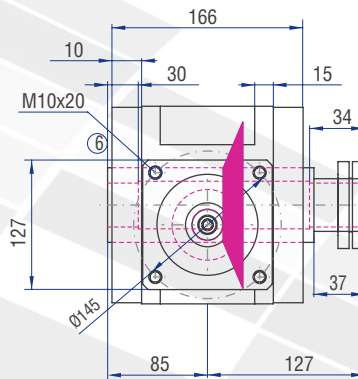
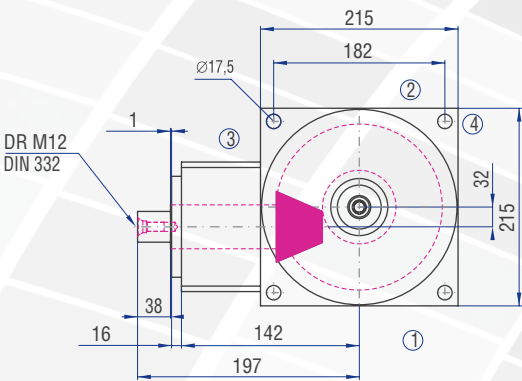
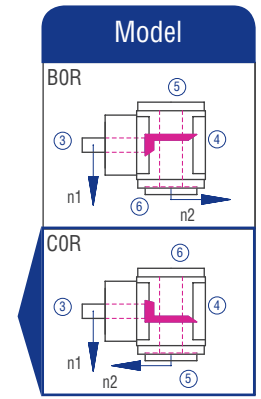
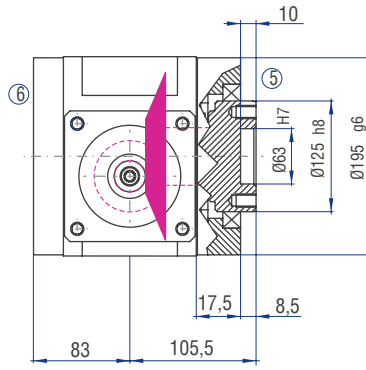
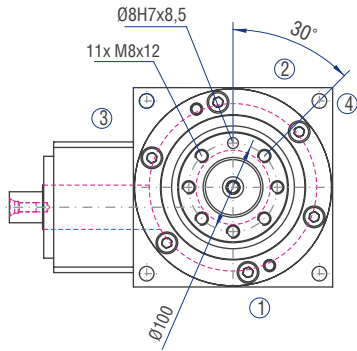

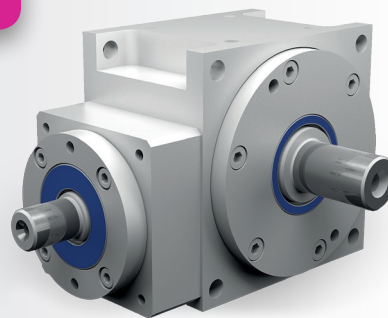

Characteristics

Characteristic	Standard	Option
Toothing	Spiral-toothed, hardened hypoid bevel gears	See chapter 8.2.1
Gear ratio	3:1 to 15:1	
Housing / Flanges	Aluminium / steel or casting	
Threaded mounting holes	On the sides 1, 2 and 3	See chapter 8.2.3
Shaft	Material 1 C45, shaft ends greased Fit with ISO 6 tolerance	See chapter 4.6.2
Hollow shaft	Material 1 C45, shafts greased Fit with ISO 6 tolerance	See chapter 4.6.3
Radial shaft seal ring	NBR, form A	See chapter 4.8
Ambient temperature	-10°C to +90°C. The values of the performance tables are valid for +20°C	See chapter 4.9.3
Circumferential backlash	< 4 arcmin	See chapter 8.2.10
Protection class	IP 64	See chapter 4.5
Corrosion protection	Prime coat; layer thickness >40 µm	See chapter 4.4
Bearing life L10h	more than 30,000h in S5 operation	See chapter 4.9.1
Oil change intervals	Not required if the oil temperature is kept < 90°C. The lifetime of the bearings can be increased by the factor 1.5 if the oil is changed after the first 500 service hours and then every 5000 service hours.	See chapter 8.2.8
Lubricants	Synthetic lubricants	See chapter 8.2.8

Performance data

N ₁ [rpm]	N ₁ MAX [rpm]	3:1			4:1			5:1			6:1			8:1			10:1			12:1			15:1		
		T _{2N} [Nm]	T _{2B} [Nm]	T _{2NOT} [Nm]	T _{2N} [Nm]	T _{2B} [Nm]	T _{2NOT} [Nm]	T _{2N} [Nm]	T _{2B} [Nm]	T _{2NOT} [Nm]	T _{2N} [Nm]	T _{2B} [Nm]	T _{2NOT} [Nm]	T _{2N} [Nm]	T _{2B} [Nm]	T _{2NOT} [Nm]	T _{2N} [Nm]	T _{2B} [Nm]	T _{2NOT} [Nm]	T _{2N} [Nm]	T _{2B} [Nm]	T _{2NOT} [Nm]	T _{2N} [Nm]	T _{2B} [Nm]	T _{2NOT} [Nm]
1300	4500	0	0	0	0	0	0	0	0	0	0	0	0	0	0	0	0	0	0	1023	1533	2044	1023	1533	2044
1000	4500	0	0	0	0	0	0	0	0	0	0	1444	2165	2880	1444	2165	2880	1444	2165	2880	0	0	0	0	0
550	4500	1444	2165	2880	1444	2165	2880	1444	2165	2880	0	0	0	0	0	0	0	0	0	0	0	0	0	0	0

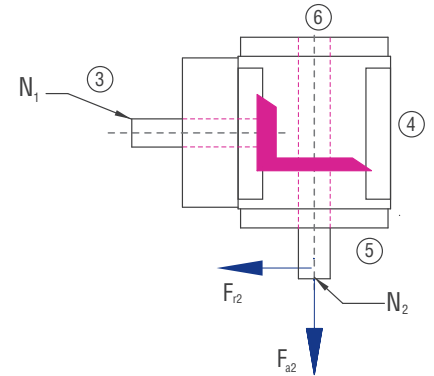

Permissible radial force F_{r2} and axial force F_{a2} on shaft N₂

3:1		4:1		5:1		6:1		8:1		10:1		12:1		15:1	
F_{r2} [N]	F_{a2} [N]	F_{r2} [N]	F_{a2} [N]	F_{r2} [N]	F_{a2} [N]	F_{r2} [N]	F_{a2} [N]	F_{r2} [N]	F_{a2} [N]	F_{r2} [N]	F_{a2} [N]	F_{r2} [N]	F_{a2} [N]	F_{r2} [N]	F_{a2} [N]
22500	11250	22500	11250	22500	11250	22500	11250	22500	11250	22500	11250	22500	11250	22500	11250

Gearbox inertia moments/mass

Inertia moment J_1 related to the fast-rotating shaft (N₁)

Inertia moment [kgcm ²]								Mass ca. [kg]
3:1	4:1	5:1	6:1	8:1	10:1	12:1	15:1	
91,4700	62,4300	44,2900	39,5500	27,0700	21,4300	18,1400	15,5300	60

The mass of the gearbox may deviate depending on the type and the gear ratio.

8.3.11 Type H 260 – Standard hypoid gearboxes

