

Made in Germany

ATEK

ANTRIEBSTECHNIK

Das Winkelgetriebe



Hygiene-design
gearboxes

Type: HDV



Miniature
bevel gearboxes

Bevel
gearboxes

Hygiene-design
gearboxes

Hybrid
gearboxes

Worm
gearboxes

Gearbox
motors

Servo gearboxes
(precision gearboxes)

Special
gearboxes

ATEX
gearboxes

Gear sets

Service

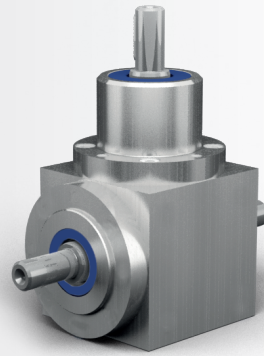

7.1 Type overview

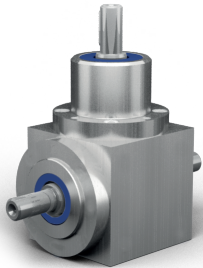

Type HDV – Hygiene-design bevel gearboxes

Gear ratios: $i = 1:1$ to $6:1$
Maximum output torque: 430 Nm
4 gearbox sizes with edge lengths of 065 to 140 mm
Low-backlash construction < 10 angular minutes possible
All outside parts made of VA steel

7.2 Type HDV – Hygiene-design bevel gearboxes

The HDV-series gearboxes are intended for the use in food and pharmaceutical industries (including offshore and rough conditions). They are based on our proven standard gearboxes from the range of single-stage bevel gearboxes (V series) and have therefore the same external dimensions.

They vary in the following features:

- All outside parts are made of high-quality stainless steel.
- The shaft seal rings installed in the type have an additional dust lip.
- The housing and the flanges do not contain any bores or other dust pockets.
- Required mounting bores will be drilled application-specifically according to your specifications.
- The dimensions of the gearboxes are identical to those of the type-V gearboxes.
- Etched type plate
- No vent filters
- Surface roughness < Ra 0.8
- NOTOX lubrication

7.2.1 General construction

The axles intersect in the gearbox in an angle of 90°. Housing, cover(s) and shafts are made of stainless steel. The edge length of the housing is reflected in the gearbox size (example: HDV 065 – housing edge length 65 mm).

7.2.2 Toothing

ATEK bevel gearboxes have gear sets with high-quality spiral tothing made of hardened carburised steel. A gear set comprises one bevel pinion (small number of teeth / small diameter) and one bevel gear (large number of teeth / large diameter).

Gear sets with spiral tothing offer the advantage of very favourable engagement factors (high meshing ratio). Therefore they are predestined for usage with high loads, combined with optimal running smoothness and high transmission accuracy.

7.2.3 Construction types

Due to the modular system, different gearbox construction types can be configured. The construction types vary in

Construction type	consists of:	
A0 through E0	1 gear set	
F0 through K0	1 gear set	+ 1 bevel pinion or bevel gear

Table 7.2.3-1

The variants differ in type and number of the shafts, the rotational direction of the shafts and their support by bearings.

7.2.4 Threaded mounting holes

All 6 sides of the gearboxes are machined and may be used as mounting surfaces. The standard version has no threaded mounting holes. Threaded mounting holes will be drilled according to your requirements.

You have the following available ordering options:

Order code	Threaded mounting holes are in the housing surfaces on the gearbox side	Threaded mounting holes are in the flanges on the gearbox side
0	-	-
1	1	
2	2	
3		3
4	4	
5		5
6		6

Table 7.2.4-1

7 Hygiene-design gearboxes

The standard version of the mounting / fastening has the order code 0.

Example of order code: HDV 090 1:1D0 1.1 500/0000

The size and the position of the threaded mounting holes correspond to those of the type V (page 29 and following)

	HDV 065	HDV 090	HDV 120	HDV 140
Thread size	M6 x 12	M8 x 14	M10 x 16	M10 x 20
Grid spacing (mm)	45	70	100	110

Tabelle 7.2.4-2

7.2.5 Installation position

The gearboxes can be used in all installation positions. The recommended installation position is the position in which the shafts are horizontal. These are the installation positions 1 and 2. The installation position is defined by the gearbox side directed downwards during operation and will be indicated by the corresponding gearbox side. Please contact us for consultation if the angle of the gearbox side directed downwards deviates more than 15° from the horizontal position.

7.2.6 Shaft designation – allocation to the gearbox sides

The fast-rotating shaft has the speed n_1 and is identified by N_1 . The bevel pinion is located on this shaft.

The slowly rotating shaft has the speed n_2 and is identified by N_2 . The bevel gear is located on this shaft. The gearbox sides are identified by the numerals 1 to 6 (see Figure 4.3.1-1 Gearbox sides)

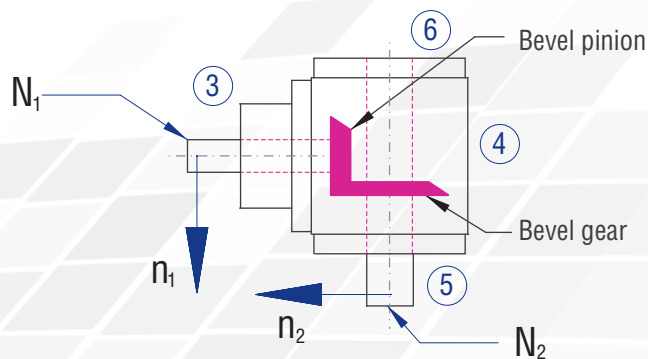

Figure 7.2.6-1; Shaft designations

7.2.7 Preferred direction of rotation

If the clockwise (CW) direction of rotation (viewing direction from shaft end face of the fast-rotating shaft towards the gearbox centre) is selected, a 1 to 2 dB(A) lower noise level is generated.

7.2.8 Efficiency

The achievable efficiency depends on rotational speed, torque, installation position, sealing, and lubricant type.

With gearboxes having only one gear set, an efficiency of 97% can be achieved. With gearboxes having several gear meshings, an efficiency of 94% can be achieved. The efficiencies specified in the tables relate to the permissible nominal load and are guidance values for run-in gearboxes at operating temperature with standard sealing and filled with oil of viscosity grade 220.

7.2.9 Lubrication

The HDV-series gearboxes have lifetime NOTOX lubrication.

7.2.10 Vent filter

No venting is provided.

7.2.11 Low-backlash construction

For low-friction running, the tooth space in the gear set is manufactured larger than the tooth. When the direction of rotation is changed, this results in a rotation angle until the counter-rotating tooth flanks contact each other. This rotation angle is called circumferential backlash.

Circumferential backlash, measuring method

The circumferential backlash is measured after the drive shaft (N1) has been fixed. A force of around 2% of the nominal torque is applied to the output shaft (N2) in both rotational directions. A tooth backlash will result between the two final positions. This can be measured as rotation angle and is indicated in minutes of arc [arcmin].

Circumferential backlash, type

Ordering option	Gear set	1:1 2:1	3:1 4:1 5:1 6:1
/0000	Standard	≤ 30 arcmin	≤ 30 arcmin
/S2	Standard	≤ 10 arcmin	≤ 10 arcmin
/S1	Standard	≤ 6 arcmin	u.r.
/S0	Special gear set	≤ 4 arcmin	u.r.

Abbreviations: ✓ - yes, is possible

7.2.12 Corrosion protection

Housing, flanges and shafts are made of rust-proof stainless steel.

7.2 Type HDV – Hygiene-design bevel gearboxes

7.2.13 Features

Gear ratios: $i = 1:1$ to $6:1$
 Maximum output torque: 430 Nm
 4 gearbox sizes with edge lengths of 065 to 140 mm
 Low-backlash construction < 10 angular minutes possible
 All outside parts made of VA steel

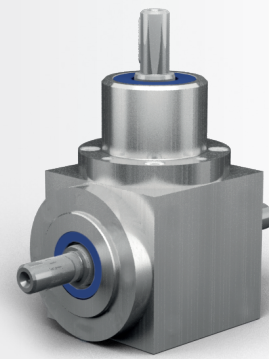

7.2.14 Models

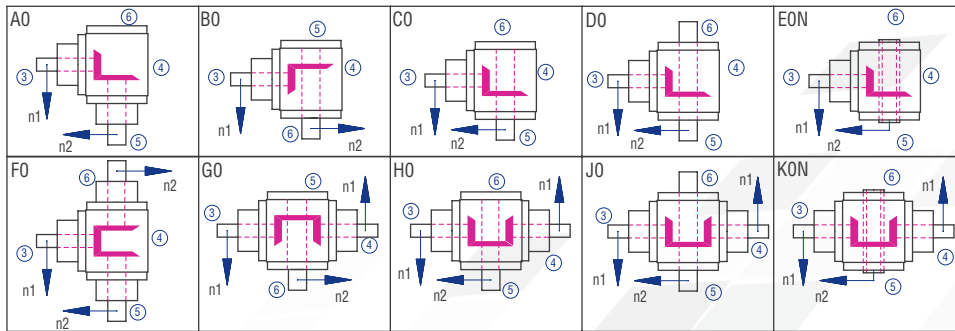

Figure 7.2.14-1; Models

7.2.15 Gearbox sides

The example shows the Model C0

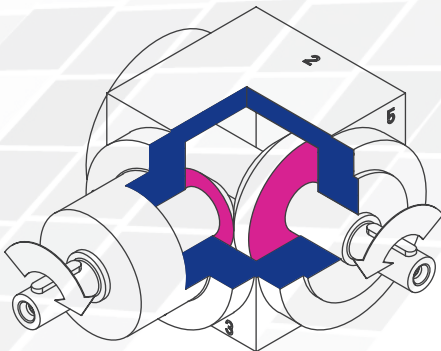

Figure 7.2.15-1; Gearbox sides

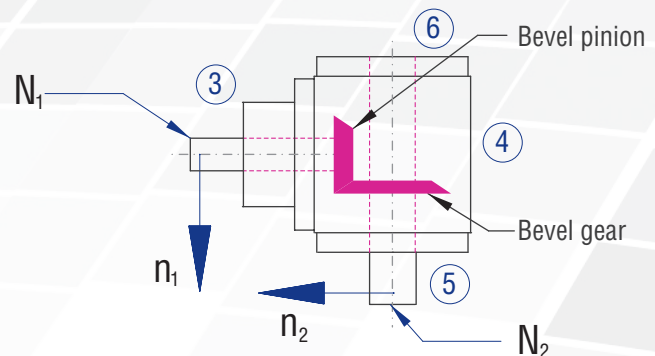

Figure 7.2.15-2; Shaft designations

7.2.16 Order code

The order code reflects the customer specifications. Example:

Type	Size	Gear ratio	Model	Fixing side	Installation position	Speed n_2	Design
HDV	065	1:1	C0-	1.	1-	500	/0000
Description	Housing edge length; Table 7.2.17-1	Table 7.2.17-1	Figure 7.2.14-1; Models	Side on which fixing is made; Table 7.2.4-1; Figure 4.3.1-1 Gearbox sides	Side directed downwards; Figure 4.3.1-1 Gearbox sides	Slowly rotating shaft; Table 7.2.17-1	S1 Standard

7.2.17 Overview of performance data

Size	n ₁ [rpm]	1:1			1.5:1			2:1			3:1			4:1			5:1			6:1			
		n ₂ [rpm]	P _{1N} [kW]	T _{2N} [Nm]	n ₂ [rpm]	P _{1N} [kW]	T _{2N} [Nm]	n ₂ [rpm]	P _{1N} [kW]	T _{2N} [Nm]	n ₂ [rpm]	P _{1N} [kW]	T _{2N} [Nm]	n ₂ [rpm]	P _{1N} [kW]	T _{2N} [Nm]	n ₂ [rpm]	P _{1N} [kW]	T _{2N} [Nm]	n ₂ [rpm]	P _{1N} [kW]	T _{2N} [Nm]	
065	3000	3.31	10	2000	2.20	10	1500	1.65	10	1000	1.10	10											
	2400	2.65	10	1600	1.76	10	1200	1.32	10	800	0.88	10											
	1500	1.82	11	1000	1.21	11	750	0.91	11	500	0.61	11											
	1000	1.32	12	667	0.88	12	500	0.66	12	333	0.44	12											
	750	1.07	13	500	0.72	13	375	0.54	13	250	0.33	12											
	500	0.83	15	333	0.55	15	250	0.41	15	167	0.24	13											
	250	0.47	17	167	0.31	17	125	0.23	17	83	0.12	13											
	50	0.10	18	33	0.07	18	25	0.05	18	17	0.03	14											
090	3000	8.93	27	2000	5.51	25	1500	3.80	23	1000	2.54	23	750	1.90	23	600	1.52	23	500	1.25	23	23	
	2400	7.41	28	1600	4.59	26	1200	3.17	24	800	2.12	24	600	1.65	25	480	1.32	25	400	1.09	25	25	
	1500	5.29	32	1000	3.20	29	750	2.23	27	500	1.49	27	375	1.12	27	300	0.89	27	250	0.74	27	27	
	1000	3.75	34	667	2.35	32	500	1.71	31	333	1.14	31	250	0.85	31	200	0.68	31	167	0.53	29	29	
	750	3.06	37	500	1.93	35	375	1.32	32	250	0.88	32	188	0.66	32	150	0.53	32	125	0.40	29	29	
	500	2.20	40	333	1.36	37	250	0.94	34	167	0.63	34	125	0.47	34	100	0.37	34	83	0.27	29	29	
	250	1.21	44	167	0.74	40	125	0.50	36	83	0.33	36	63	0.25	36	50	0.20	36	42	0.14	30	30	
	50	0.28	50	33	0.16	45	25	0.10	37	17	0.07	37	13	0.05	37	10	0.04	37	8	0.03	33	33	
120	3000	21.82	66	2000	13.45	61	1500	9.26	56	1000	6.39	58	750	4.96	60	600	3.97	60	500	2.95	54	54	
	2400	18.52	70	1600	11.46	65	1200	8.07	61	800	5.56	63	600	4.43	67	480	3.44	65	400	2.53	57	57	
	1500	13.56	82	1000	8.60	78	750	6.03	73	500	4.08	74	375	3.06	74	300	2.38	72	250	1.75	64	64	
	1000	10.14	92	667	6.32	86	500	4.46	81	333	3.01	82	250	2.18	79	200	1.76	80	167	1.22	66	66	
	750	8.51	103	500	5.18	94	375	3.55	86	250	2.40	87	188	1.69	82	150	1.42	86	125	0.94	68	68	
	500	6.34	115	333	3.85	100	250	2.54	92	167	1.66	90	125	1.16	84	100	0.98	89	83	0.63	69	69	
	250	3.39	123	167	1.99	100	125	1.35	98	83	0.87	95	63	0.60	87	50	0.51	92	42	0.33	71	71	
	50	0.72	130	33	0.41	100	25	0.29	107	17	0.21	110	13	0.12	90	10	0.10	95	8	0.06	66	66	
140	3000	39.68	120	2000	24.91	113	1500	16.53	100	1000	12.12	110	750	8.51	103	600	6.61	100	500	5.18	94	94	
	2400	37.04	140	1600	22.22	126	1200	14.68	111	800	11.46	130	600	7.34	111	480	5.56	105	400	4.58	104	104	
	1500	26.78	162	1000	17.08	155	750	11.41	138	500	8.05	146	375	4.96	120	300	3.80	115	250	2.95	107	107	
	1000	20.28	184	667	12.87	175	500	8.38	152	333	5.87	160	250	3.75	136	200	2.73	124	167	2.06	112	112	
	750	16.20	196	500	10.47	190	375	6.86	166	250	4.60	167	188	3.06	148	150	2.15	130	125	1.61	117	117	
	500	11.46	208	333	7.34	200	250	4.96	180	167	3.20	174	125	2.12	154	100	1.50	136	83	1.09	119	119	
	250	5.92	215	167	3.76	204	125	2.62	190	83	1.62	177	63	1.12	162	50	0.79	143	42	0.56	121	121	
	50	1.21	220	33	0.76	210	25	0.55	200	17	0.34	180	13	0.23	170	10	0.17	150	8	0.11	120	120	

Table 7.2.17-1

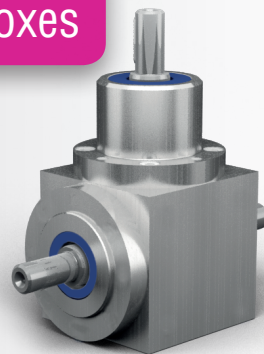

Characteristics

Characteristic	Standard	Option
Toothing	Spiral toothed bevel gear set	See chapter 7.2.2
Gear ratios	1:1 to 3:1	
Housing / Flanges	1.4581 / 1.4305	See chapter 7.2.1
Threaded mounting holes	Customer-specific	See chapter 7.2.4
Shaft	1.4305, shaft ends greased Fit with ISO 6 tolerance with parallel keyway: according to DIN 6885 Sheet 1	See chapter 4.6.2
Hollow shaft	1.4305, shafts greased Fit with ISO 7 tolerance with parallel keyway: according to DIN 6885 Sheet 1	See chapter 4.6.3
Radial shaft seal ring:	NBR, form A	See chapter 4.8
Ambient temperature	-10°C to +90°C. The values of the performance tables are valid for +20°C	See chapter 4.9.3
Circumferential backlash	< 30 arcmin	See chapter 7.2.11
Protection class	IP 56	See chapter 4.5
Corrosion protection	-	See chapter 7.2.12
Bearing life L10h:	more than 15,000h	See chapter 4.9.1
Oil change intervals	Not required	See chapter 7.2.9
Lubricants	Synthetic lubricant, NSF-approved (NOTOX)	See chapter 7.2.9
Type plate	Etched	

Performance data

n_1 [rpm]	1:1			1.5:1			2:1			3:1			4:1			5:1			6:1			
	n_2 [rpm]	P_{1N} [kW]	T_{2N} [Nm]	n_2 [rpm]	P_{1N} [kW]	T_{2N} [Nm]	n_2 [rpm]	P_{1N} [kW]	T_{2N} [Nm]	n_2 [rpm]	P_{1N} [kW]	T_{2N} [Nm]	n_2 [rpm]	P_{1N} [kW]	T_{2N} [Nm]	n_2 [rpm]	P_{1N} [kW]	T_{2N} [Nm]	n_2 [rpm]	P_{1N} [kW]	T_{2N} [Nm]	
3000	3000	3.31	10	2000	2.20	10	1500	1.65	10	1000	1.10	10										
2400	2400	2.65	10	1600	1.76	10	1200	1.32	10	800	0.88	10										
1500	1500	1.82	11	1000	1.21	11	750	0.91	11	500	0.61	11										
1000	1000	1.32	12	667	0.88	12	500	0.66	12	333	0.44	12										
750	750	1.07	13	500	0.72	13	375	0.54	13	250	0.33	12										
500	500	0.83	15	333	0.55	15	250	0.41	15	167	0.24	13										
250	250	0.47	17	167	0.31	17	125	0.23	17	83	0.12	13										
50	50	0.10	18	33	0.07	18	25	0.05	18	17	0.03	14										
P_{1Nt} [kW]	1.4			1.4			1.4			1.4												
T_{2max} [Nm]	25			25			25			23												

The mass of the gearbox may deviate depending on the gear ratio.

Permissible radial force F_{r1} and axial force F_{a1} on shaft N_1

The permissible radial forces depend on torque, rotational speed and direction.

They must be calculated for the respective case of application. Please enquire these.

n_1 [rpm]	3000		1000		500		250		100		50	
T_2 [Nm]	F_r [N]	F_a [N]	F_r [N]	F_a [N]	F_r [N]	F_a [N]	F_r [N]	F_a [N]	F_r [N]	F_a [N]	F_r [N]	F_a [N]
< 12	180	90	250	125	300	150	350	175	450	225	550	275
> 12	150	75	210	105	250	125	290	145	380	190	460	230

Permissible radial force F_{r2} and axial force F_{a2} on shaft N_2

n_2 [rpm]	3000		1000		500		250		100		50	
T_2 [Nm]	F_r [N]	F_a [N]	F_r [N]	F_a [N]	F_r [N]	F_a [N]	F_r [N]	F_a [N]	F_r [N]	F_a [N]	F_r [N]	F_a [N]
< 12	300	150	400	200	500	250	650	325	750	375	900	450
> 12	250	125	330	165	420	210	540	270	630	315	750	375

Inertia moments/mass

The mass of the gearbox may deviate depending on the gear ratio.

Model	Inertia moment [kgcm ²]						
	1:1	1.5:1	2:1	3:1	4:1	5:1	6:1
AO	0.3888	0.2406	0.1839	0.1036			
BO	0.4231	0.3111	0.2330	0.1001			
CO	0.4231	0.3111	0.2330	0.1001			
DO	0.4330	0.3155	0.2355	0.1012			
EON	0.4754	0.3634	0.2853	0.1524			
EOS	0.6012	0.4892	0.4111	0.2782			
FO	0.5832	0.3270	0.2325	0.1252			
GO	0.6175	0.4653	0.3683	0.1821			
HO	0.6175	0.4653	0.3683	0.1821			
JO	0.6274	0.4697	0.3708	0.1832			
KON	0.6698	0.5176	0.4206	0.2344			
KOS	0.7956	0.6434	0.5464	0.3602			

Mass [kg]
2.3
2.2
2.2
2.3
2.1
2.1
2.7
2.6
2.6
2.7
2.5
2.5

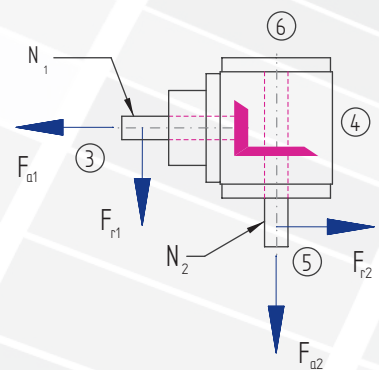

7.2.18 Type HDV 065 – Hygiene-design bevel gearboxes

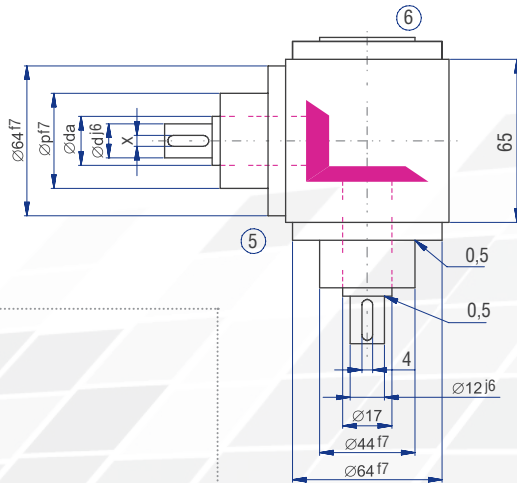
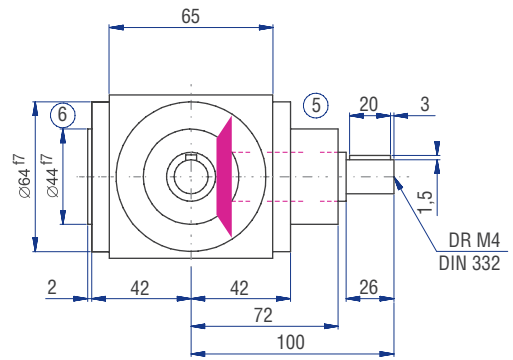
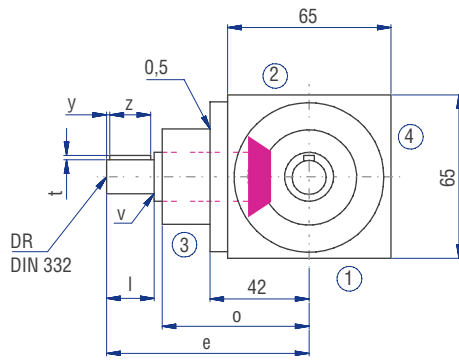
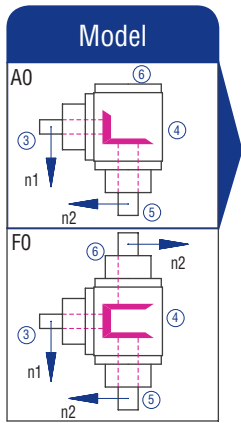

	Gear ratio						
	1:1	1.5:1	2:1	3:1	4:1	5:1	6:1
d [mm]	17	17	17	17			
da [mm]	12	12	12	12			
l [mm]	100	100	100	100			
v [mm]	26	26	26	26			
x [mm]	72	72	72	72			
y [mm]	44	44	44	44			
z [mm]	1.5	1.5	1.5	1.5			
t [mm]	0.5	0.5	0.5	0.5			
e [mm]	4	4	4	4			
o [mm]	3	3	3	3			
p [mm]	20	20	20	20			
DR M	4	4	4	4			

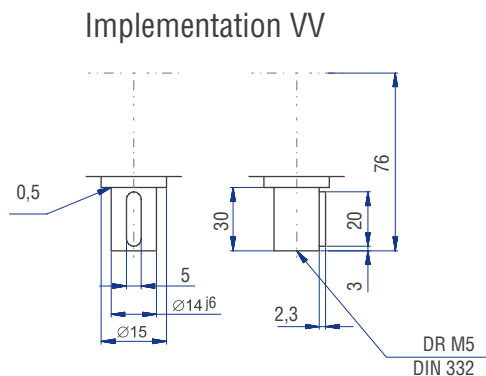
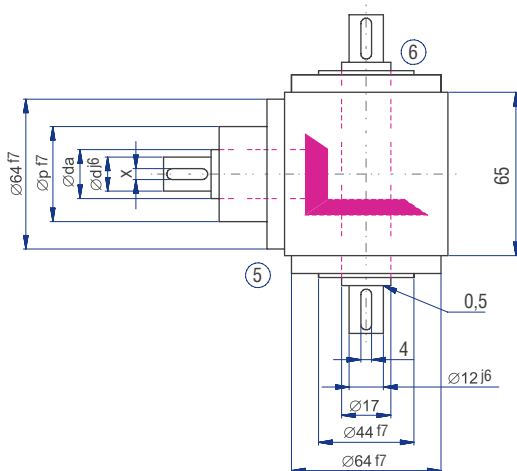
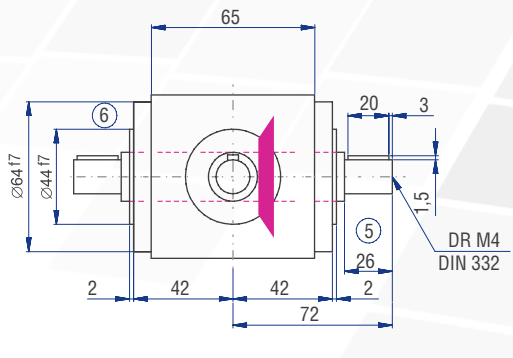
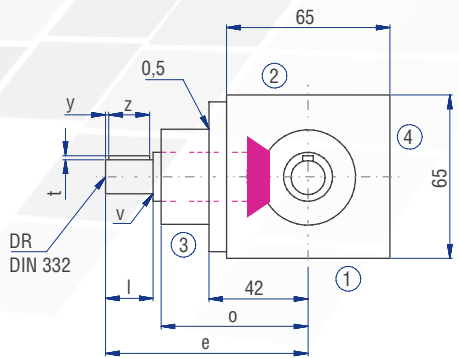
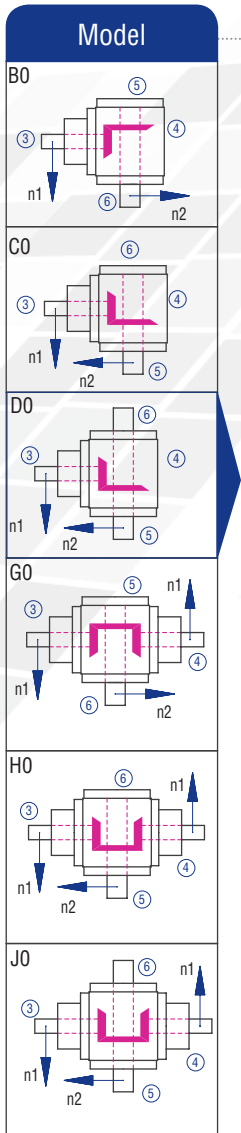

The dimensions of the Models not shown can be figured by mirroring available dimensions.

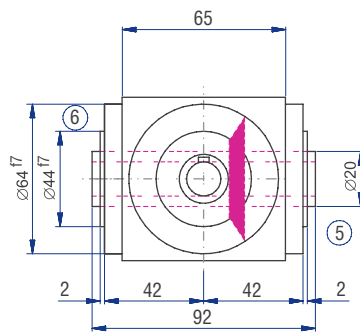
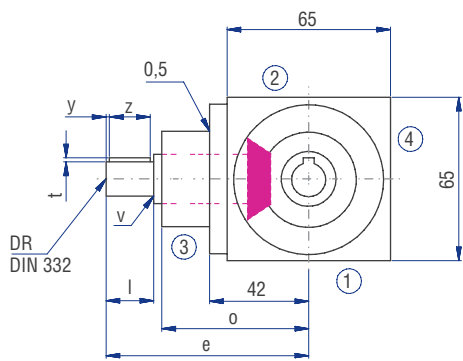

Implementation

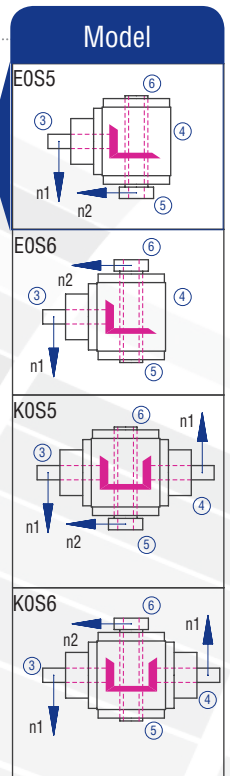
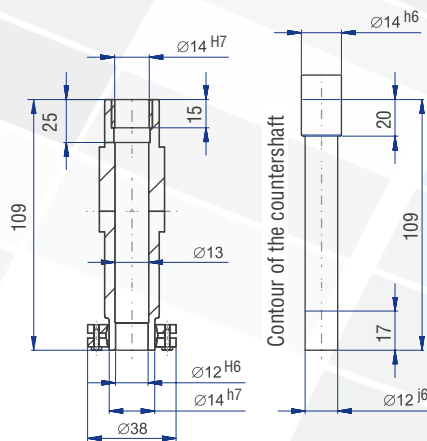
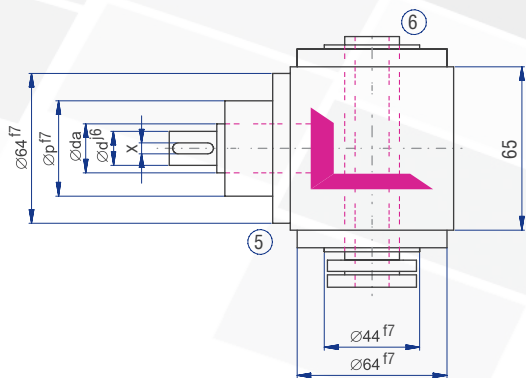
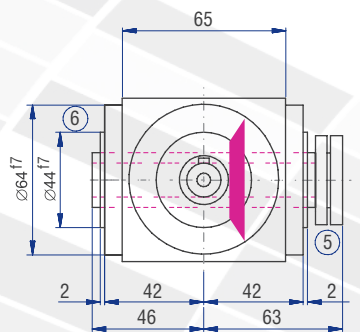
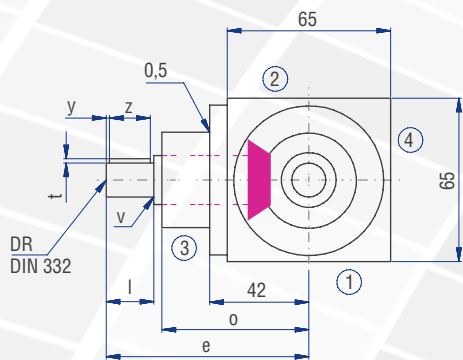
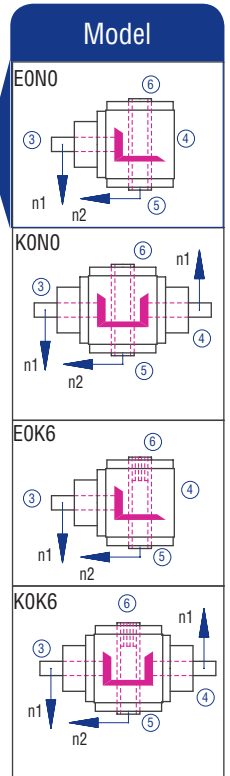
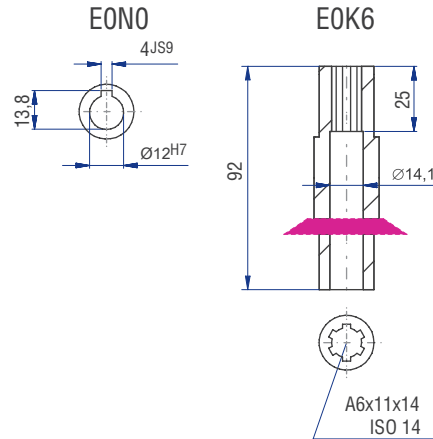
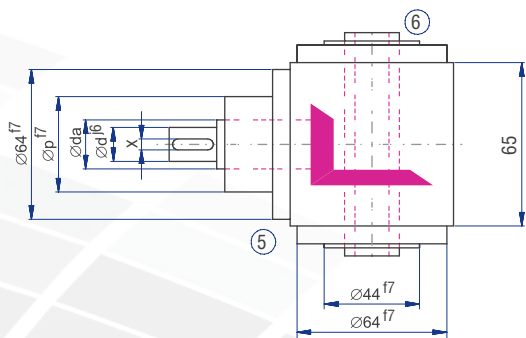

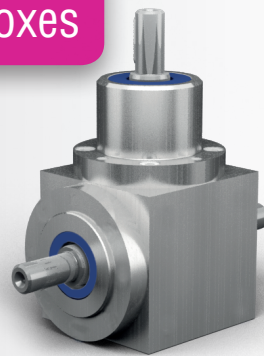

Characteristics

Characteristic	Standard	Option
Toothing	Spiral toothed bevel gear set	See chapter 7.2.2
Gear ratios	1:1 to 6:1	
Housing / Flanges	1.4581 / 1.4305	See chapter 7.2.1
Threaded mounting holes	Customer-specific	See chapter 7.2.4
Shaft	1.4305, shaft ends greased Fit with ISO 6 tolerance with parallel keyway: according to DIN 6885 Sheet 1	See chapter 4.6.2
Hollow shaft	1.4305, shafts greased Fit with ISO 7 tolerance with parallel keyway: according to DIN 6885 Sheet 1	See chapter 4.6.3
Radial shaft seal ring:	NBR, form A	See chapter 4.8
Ambient temperature	-10°C to +90°C. The values of the performance tables are valid for +20°C	See chapter 4.9.3
Circumferential backlash	< 30 arcmin	See chapter 7.2.11
Protection class	IP 56	See chapter 4.5
Corrosion protection	-	See chapter 7.2.12
Bearing life L10h:	more than 15,000h	See chapter 4.9.1
Oil change intervals	Not required	See chapter 7.2.9
Lubricants	Synthetic lubricant, NSF-approved (NOTOX)	See chapter 7.2.9
Type plate	Etched	

Performance data

n_1 [rpm]	1:1			1.5:1			2:1			3:1			4:1			5:1			6:1		
	n_2 [rpm]	P_{1N} [kW]	T_{2N} [Nm]	n_2 [rpm]	P_{1N} [kW]	T_{2N} [Nm]	n_2 [rpm]	P_{1N} [kW]	T_{2N} [Nm]	n_2 [rpm]	P_{1N} [kW]	T_{2N} [Nm]	n_2 [rpm]	P_{1N} [kW]	T_{2N} [Nm]	n_2 [rpm]	P_{1N} [kW]	T_{2N} [Nm]	n_2 [rpm]	P_{1N} [kW]	T_{2N} [Nm]
3000	3000	8.93	27	2000	5.51	25	1500	3.80	23	1000	2.54	23	750	1.90	23	600	1.52	23	500	1.25	23
2400	2400	7.41	28	1600	4.59	26	1200	3.17	24	800	2.12	24	600	1.65	25	480	1.32	25	400	1.09	25
1500	1500	5.29	32	1000	3.20	29	750	2.23	27	500	1.49	27	375	1.12	27	300	0.89	27	250	0.74	27
1000	1000	3.75	34	667	2.35	32	500	1.71	31	333	1.14	31	250	0.85	31	200	0.68	31	167	0.53	29
750	750	3.06	37	500	1.93	35	375	1.32	32	250	0.88	32	188	0.66	32	150	0.53	32	125	0.40	29
500	500	2.20	40	333	1.36	37	250	0.94	34	167	0.63	34	125	0.47	34	100	0.37	34	83	0.27	29
250	250	1.21	44	167	0.74	40	125	0.50	36	83	0.33	36	63	0.25	36	50	0.20	36	42	0.14	30
50	50	0.28	50	33	0.16	45	25	0.10	37	17	0.07	37	13	0.05	37	10	0.04	37	8	0.03	33
P_{1Nt} [kW]	3.4			3.4			3.4			3.4			3.4			3.4			3.4		
T_{2max} [Nm]	105			45			80			70			70			60			50		

The mass of the gearbox may deviate depending on the gear ratio.

Permissible radial force F_{r1} and axial force F_{a1} on shaft N_1

The permissible radial forces depend on torque, rotational speed and direction.

They must be calculated for the respective case of application. Please enquire these.

n_1 [rpm]	3000		1000		500		250		100		50	
T_2 [Nm]	F_r [N]	F_a [N]	F_r [N]	F_a [N]	F_r [N]	F_a [N]	F_r [N]	F_a [N]	F_r [N]	F_a [N]	F_r [N]	F_a [N]
< 30	300	150	400	200	470	235	580	290	700	350	800	400
> 30	250	125	330	165	390	195	490	245	590	295	670	335

Permissible radial force F_{r2} and axial force F_{a2} on shaft N_2

n_2 [rpm]	3000		1000		500		250		100		50	
T_2 [Nm]	F_r [N]	F_a [N]	F_r [N]	F_a [N]	F_r [N]	F_a [N]	F_r [N]	F_a [N]	F_r [N]	F_a [N]	F_r [N]	F_a [N]
< 30	500	250	660	330	800	400	950	475	1250	625	1500	750
> 30	420	210	550	275	670	335	790	395	1040	520	1250	625

Inertia moments/mass

The mass of the gearbox may deviate depending on the gear ratio.

Model	Inertia moment [kgcm ²]						
	1:1	1.5:1	2:1	3:1	4:1	5:1	6:1
AO	2.5590	1.4822	1.1437	0.8884	0.3631	0.3248	0.3062
BO	3.3543	2.1833	1.3652	1.0465	0.4607	0.3933	0.3502
CO	3.3543	2.1833	1.3652	1.0465	0.4607	0.3933	0.3502
DO	3.3827	2.1959	1.3723	1.0496	0.4625	0.3945	0.3510
EON	3.2507	2.1372	1.3393	1.0350	0.4542	0.3892	0.3473
EOS	3.9213	2.4353	1.5069	1.1095	0.4961	0.4160	0.3660
FO	3.8385	2.0508	1.4636	1.0305	0.4430	0.3760	0.3418
GO	4.6338	3.0968	2.1890	1.7927	0.7438	0.6669	0.6209
HO	4.6338	3.0968	2.1890	1.7927	0.7438	0.6669	0.6209
JO	4.6622	3.1094	2.1961	1.7958	0.7456	0.6681	0.6217
KON	4.5302	3.0507	2.1631	1.7812	0.7373	0.6628	0.6180
KOS	5.2008	3.3488	2.3307	1.8557	0.7792	0.6896	0.6367

Mass
[kg]

5.1
5.4
5.4
5.5
5.0
5.2
6.3
6.9
6.9
7.0
6.5
6.7

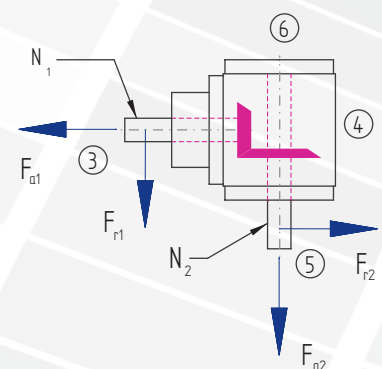

7.2.19 Type HDV 090 – Hygiene-design bevel gearboxes

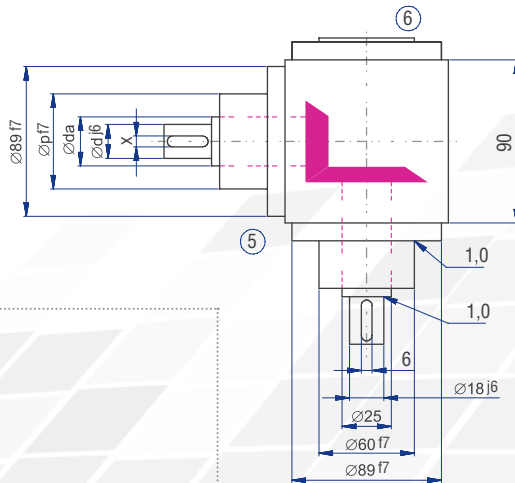
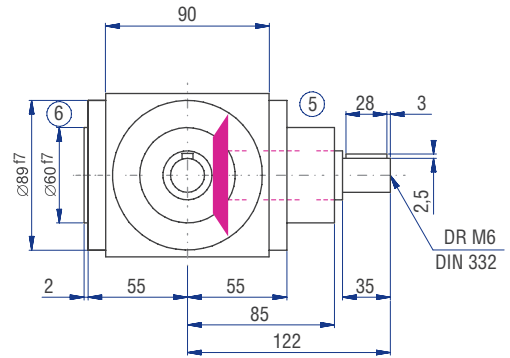
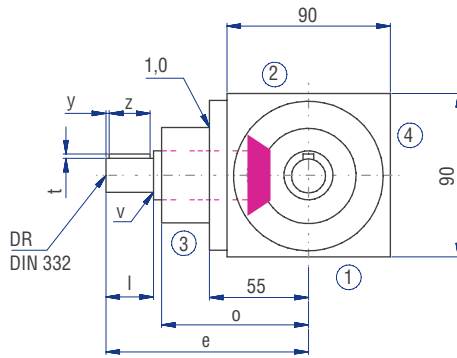
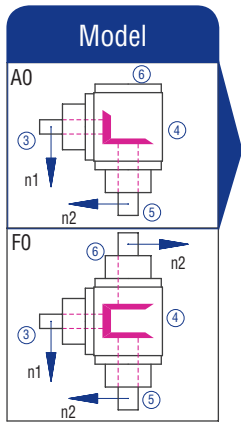

	Gear ratio						
	1:1	1.5:1	2:1	3:1	4:1	5:1	6:1
d [mm]	25	25	25	20	20	20	20
da [mm]	18	18	18	12	12	12	12
l [mm]	122	122	122	122	132	132	132
v [mm]	35	35	35	35	35	35	35
x [mm]	85	85	85	85	95	95	95
y [mm]	60	60	60	60	60	60	60
z [mm]	2.5	2.5	2.5	1.5	1.5	1.5	1.5
t [mm]	1	1	1	0.5	0.5	0.5	0.5
e [mm]	6	6	6	4	4	4	4
o [mm]	3	3	3	3	3	3	3
p [mm]	28	28	28	28	28	28	28
DR M	6	6	6	4	4	4	4

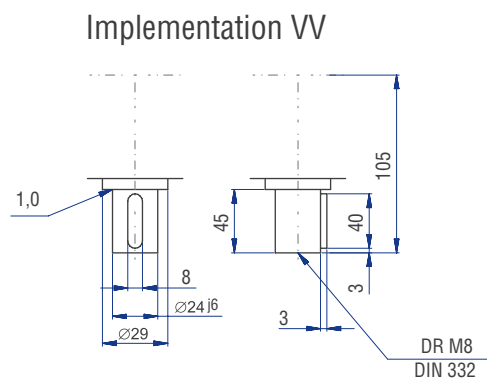
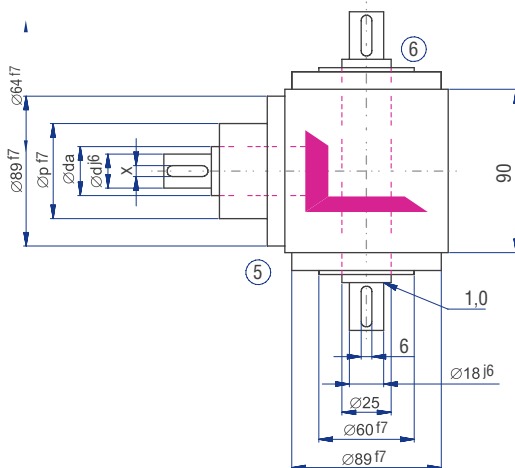
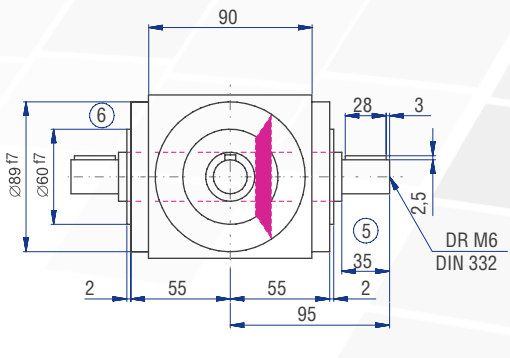
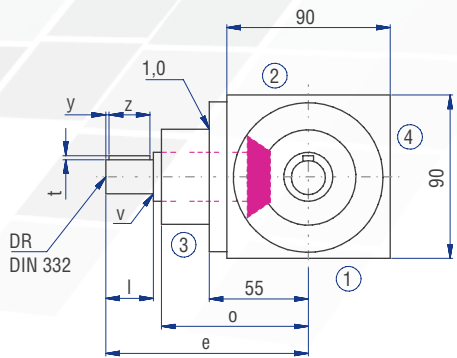
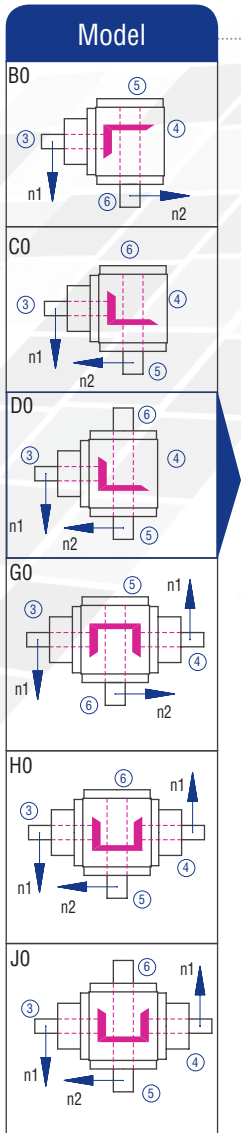

Implementation VV

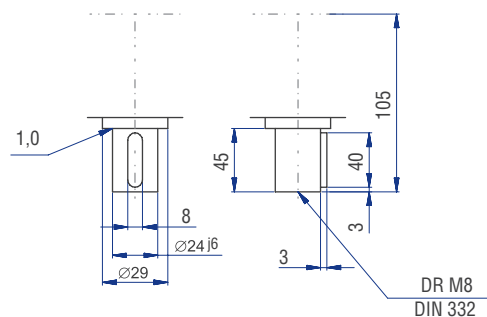

The dimensions of the Models not shown can be figured by mirroring available dimensions.

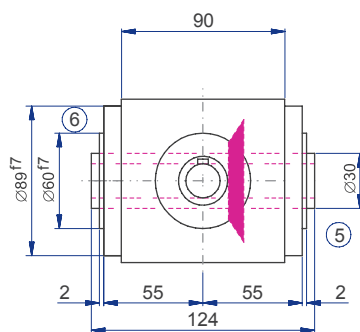
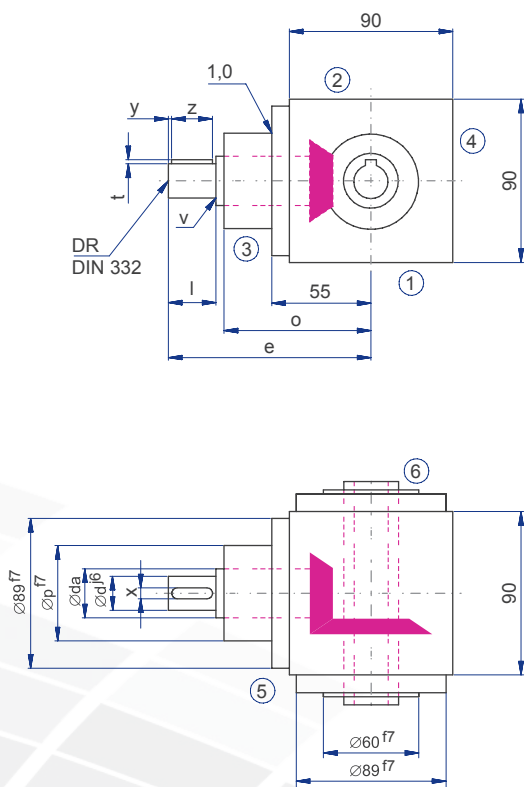

Implementation

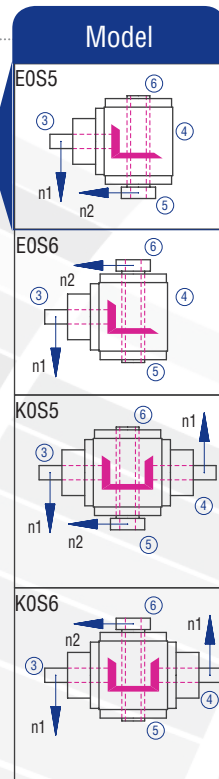
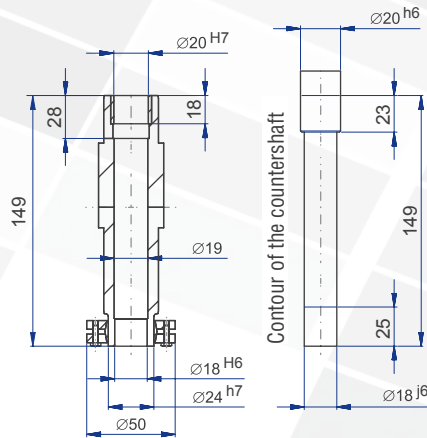
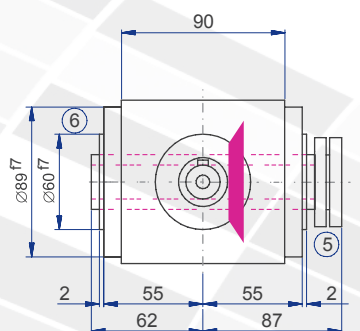
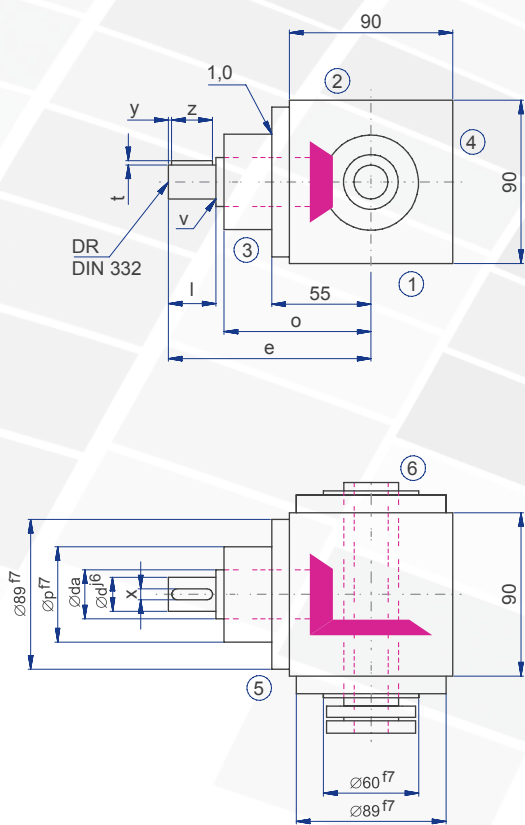
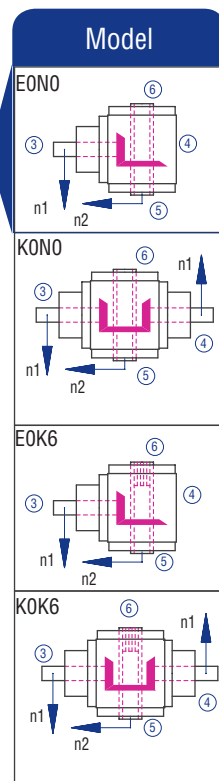
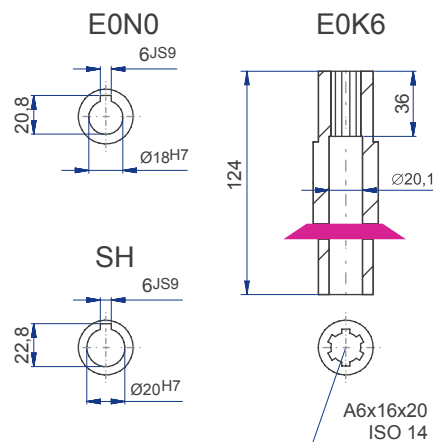

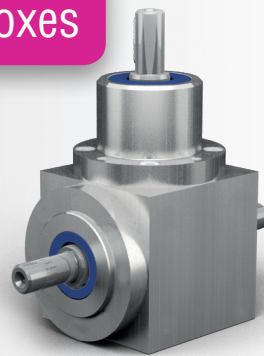

Characteristics

Characteristic	Standard	Option
Toothing	Spiral toothed bevel gear set	See chapter 7.2.2
Gear ratios	1:1 to 6:1	
Housing / Flanges	1.4581 / 1.4305	See chapter 7.2.1
Threaded mounting holes	Customer-specific	See chapter 7.2.4
Shaft	1.4305, shaft ends greased Fit with ISO 6 tolerance with parallel keyway: according to DIN 6885 Sheet 1	See chapter 4.6.2
Hollow shaft	1.4305, shafts greased Fit with ISO 7 tolerance with parallel keyway: according to DIN 6885 Sheet 1	See chapter 4.6.3
Radial shaft seal ring:	NBR, form A	See chapter 4.8
Ambient temperature	-10°C to +90°C. The values of the performance tables are valid for +20°C	See chapter 4.9.3
Circumferential backlash	< 30 arcmin	See chapter 7.2.11
Protection class	IP 56	See chapter 4.5
Corrosion protection	-	See chapter 7.2.12
Bearing life L10h:	more than 15,000h	See chapter 4.9.1
Oil change intervals	Not required	See chapter 7.2.9
Lubricants	Synthetic lubricant, NSF-approved (NOTOX)	See chapter 7.2.9
Type plate	Etched	

Performance data

n_1 [rpm]	1:1			1.5:1			2:1			3:1			4:1			5:1			6:1		
	n_2 [rpm]	P_{1N} [kW]	T_{2N} [Nm]	n_2 [rpm]	P_{1N} [kW]	T_{2N} [Nm]	n_2 [rpm]	P_{1N} [kW]	T_{2N} [Nm]	n_2 [rpm]	P_{1N} [kW]	T_{2N} [Nm]	n_2 [rpm]	P_{1N} [kW]	T_{2N} [Nm]	n_2 [rpm]	P_{1N} [kW]	T_{2N} [Nm]	n_2 [rpm]	P_{1N} [kW]	T_{2N} [Nm]
3000	3000	21.82	66	2000	13.45	61	1500	9.26	56	1000	6.39	58	750	4.96	60	600	3.97	60	500	2.95	54
2400	2400	18.52	70	1600	11.46	65	1200	8.07	61	800	5.56	63	600	4.43	67	480	3.44	65	400	2.53	57
1500	1500	13.56	82	1000	8.60	78	750	6.03	73	500	4.08	74	375	3.06	74	300	2.38	72	250	1.75	64
1000	1000	10.14	92	667	6.32	86	500	4.46	81	333	3.01	82	250	2.18	79	200	1.76	80	167	1.22	66
750	750	8.51	103	500	5.18	94	375	3.55	86	250	2.40	87	188	1.69	82	150	1.42	86	125	0.94	68
500	500	6.34	115	333	3.85	100	250	2.54	92	167	1.66	90	125	1.16	84	100	0.98	89	83	0.63	69
250	250	3.39	123	167	1.99	100	125	1.35	98	83	0.87	95	63	0.60	87	50	0.51	92	42	0.33	71
50	50	0.72	130	33	0.41	100	25	0.29	107	17	0.21	110	13	0.12	90	10	0.10	95	8	0.06	66
P_{1Nt} [kW]	5.6			5.6			5.6			5.6			5.6			5.6			5.6		
T_{2max} [Nm]	220			100			169			155			155			140			120		

The mass of the gearbox may deviate depending on the gear ratio.

Permissible radial force F_{r1} and axial force F_{a1} on shaft N_1

The permissible radial forces depend on torque, rotational speed and direction.

They must be calculated for the respective case of application. Please enquire these.

n_1 [rpm]	3000		1000		500		250		100		50	
T_2 [Nm]	F_r [N]	F_a [N]	F_r [N]	F_a [N]	F_r [N]	F_a [N]	F_r [N]	F_a [N]	F_r [N]	F_a [N]	F_r [N]	F_a [N]
< 80	470	235	620	310	720	360	900	450	1150	575	1400	700
> 80	390	195	520	260	600	300	750	375	960	480	1170	585

Permissible radial force F_{r2} and axial force F_{a2} on shaft N_2

n_2 [rpm]	3000		1000		500		250		100		50	
T_2 [Nm]	F_r [N]	F_a [N]	F_r [N]	F_a [N]	F_r [N]	F_a [N]	F_r [N]	F_a [N]	F_r [N]	F_a [N]	F_r [N]	F_a [N]
< 80	750	375	1000	500	1250	625	1500	750	1900	950	2200	1100
> 80	630	315	830	415	1040	520	1250	625	1580	790	1830	915

Inertia moments/mass

The mass of the gearbox may deviate depending on the gear ratio.

Model	Inertia moment [kgcm ²]						
	1:1	1.5:1	2:1	3:1	4:1	5:1	6:1
AO	10.4976	4.8409	3.6465	2.3159	1.2164	0.7516	0.6766
BO	15.3022	7.4441	4.9747	3.0123	1.6729	1.0593	0.8982
CO	15.3022	7.4441	4.9747	3.0123	1.6729	1.0593	0.8982
DO	15.5996	7.5762	5.0490	3.0453	1.6915	1.0712	0.9065
EON	15.1939	7.3959	4.9476	3.0003	1.6661	1.0550	0.8952
EOS	16.9812	8.1903	5.3944	3.1988	1.7778	1.1265	0.9449
FO	15.7464	7.1737	4.9587	2.8991	1.5444	0.9615	0.8224
GO	20.5510	9.9522	7.3090	4.7450	2.5612	1.6009	1.4290
HO	20.5510	9.9522	7.3090	4.7450	2.5612	1.6009	1.4290
JO	20.8484	10.0843	7.3833	4.7780	2.5798	1.6128	1.4373
KON	20.4427	9.9040	7.2819	4.7330	2.5544	1.5966	1.4260
KOS	22.2300	10.6984	7.7287	4.9315	2.6661	1.6681	1.4757

Mass
[kg]

12.6
12.3
12.3
12.5
12.0
12.3
15.0
14.7
14.7
14.9
14.4
14.7

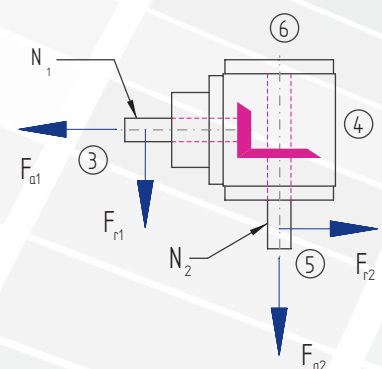

7.2.20 Type HDV 120 – Hygiene-design bevel gearboxes

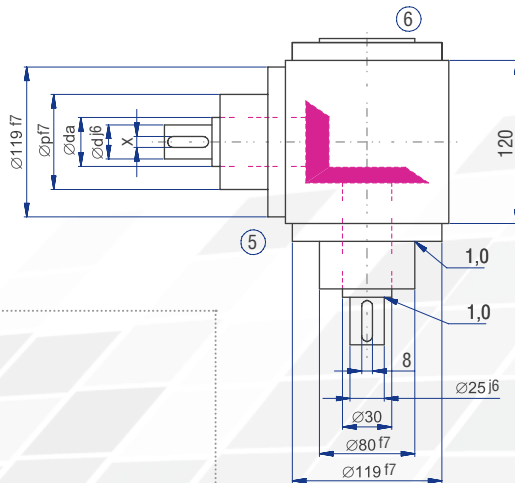
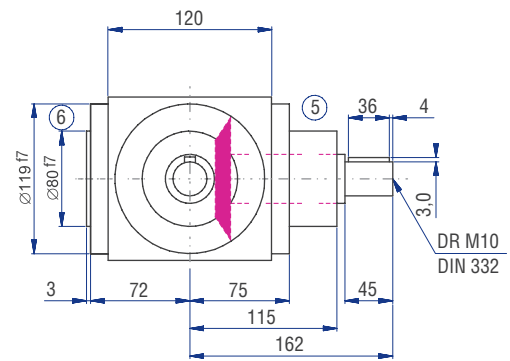
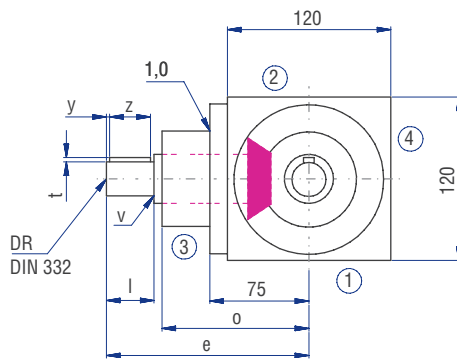
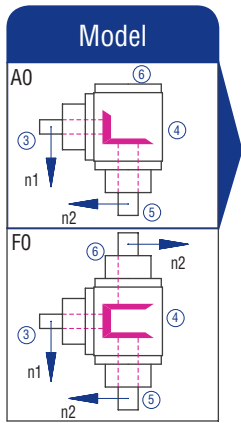

	Gear ratio						
	1:1	1.5:1	2:1	3:1	4:1	5:1	6:1
d [mm]	30	30	30	25	25	20	20
da [mm]	25	25	25	20	20	15	15
l [mm]	162	162	162	162	172	162	162
v [mm]	45	45	45	45	45	35	35
x [mm]	115	115	115	115	125	125	125
y [mm]	80	80	80	80	80	70	70
z [mm]	3	3	3	2.5	2.5	2	2
t [mm]	1	1	1	1	1	0.5	0.5
e [mm]	8	8	8	6	6	5	5
o [mm]	4	4	4	4	4	4	4
p [mm]	36	36	36	36	36	28	28
DR M	10	10	10	6	6	5	5

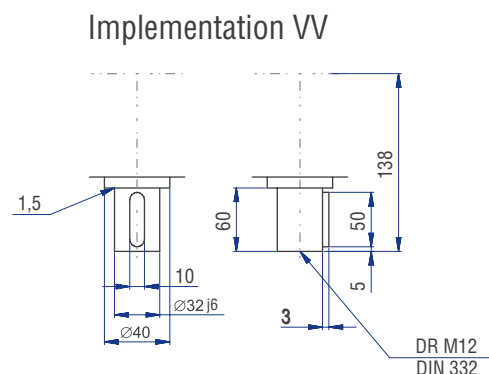
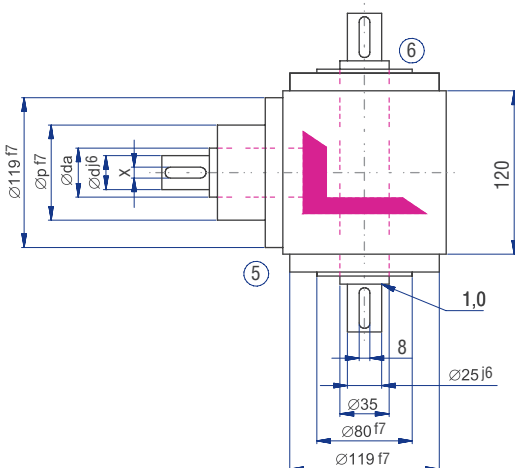
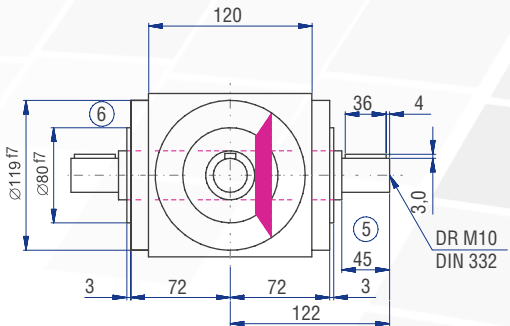
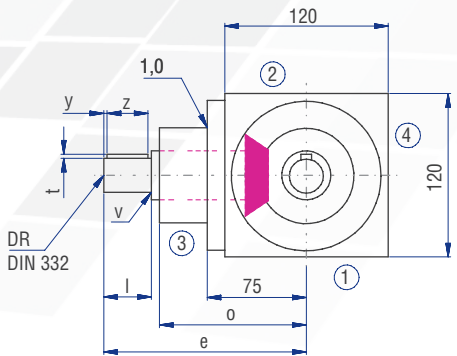
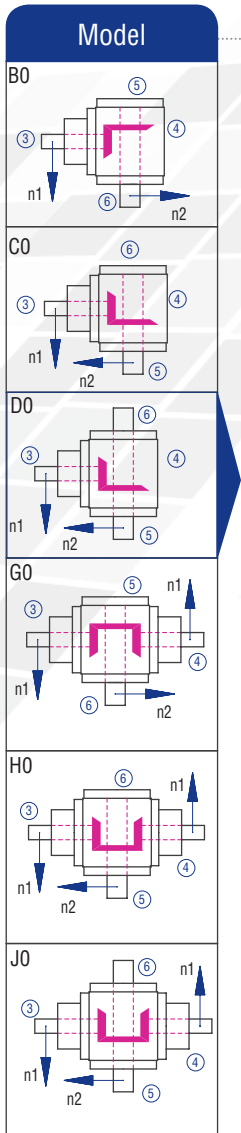

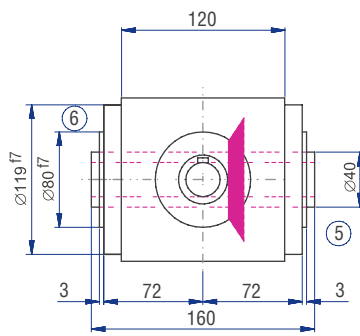
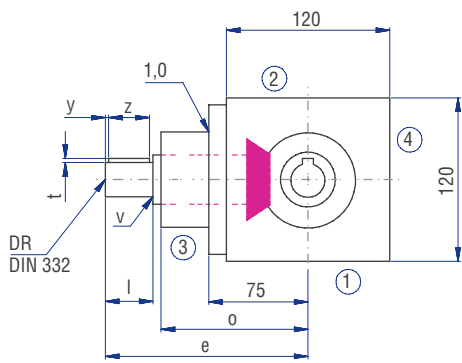

Implementation

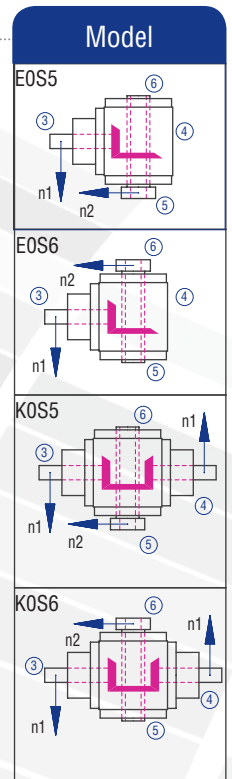
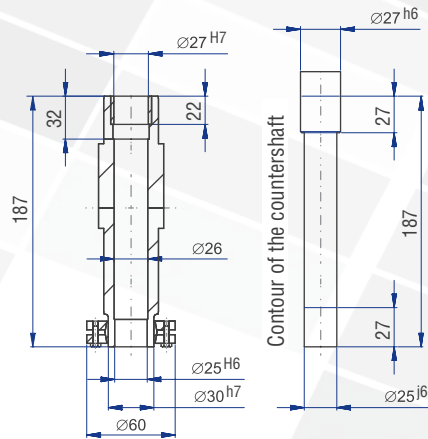
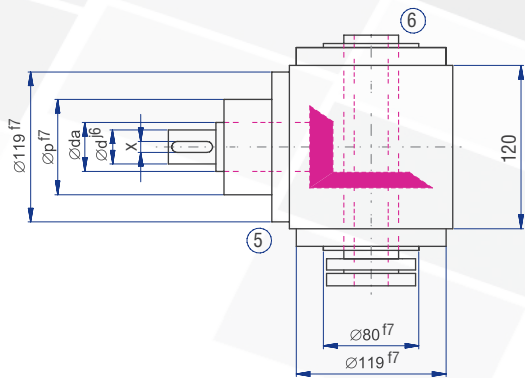
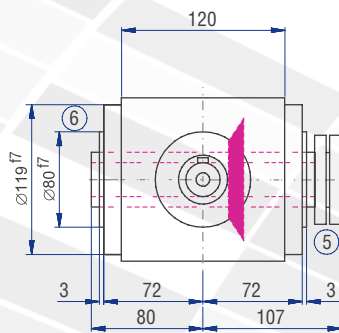
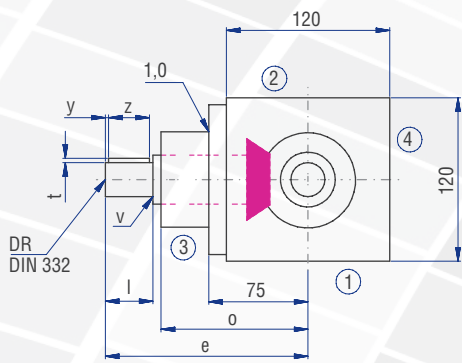
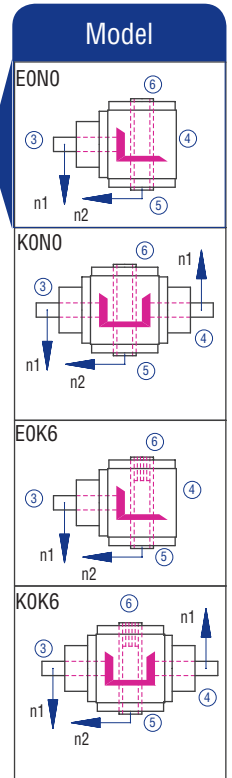
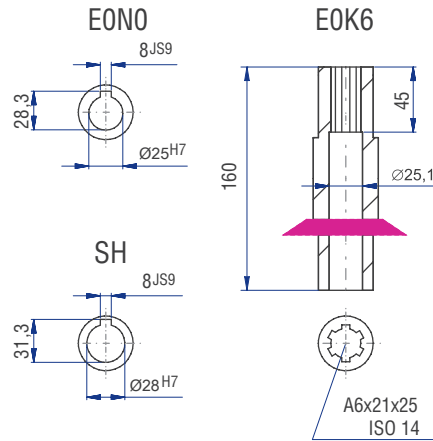
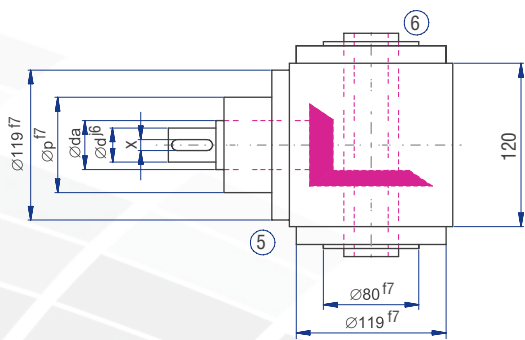

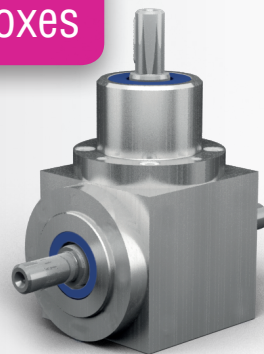

Characteristics

Characteristic	Standard	Option
Toothing	Spiral toothed bevel gear set	See chapter 7.2.2
Gear ratios	1:1 to 6:1	
Housing / Flanges	1.4581 / 1.4305	See chapter 7.2.1
Threaded mounting holes	Customer-specific	See chapter 7.2.4
Shaft	1.4305, shaft ends greased Fit with ISO 6 tolerance with parallel keyway: according to DIN 6885 Sheet 1	See chapter 4.6.2
Hollow shaft	1.4305, shafts greased Fit with ISO 7 tolerance with parallel keyway: according to DIN 6885 Sheet 1	See chapter 4.6.3
Radial shaft seal ring:	NBR, form A	See chapter 4.8
Ambient temperature	-10°C to +90°C. The values of the performance tables are valid for +20°C	See chapter 4.9.3
Circumferential backlash	< 30 arcmin	See chapter 7.2.11
Protection class	IP 56	See chapter 4.5
Corrosion protection	-	See chapter 7.2.12
Bearing life L10h:	more than 15,000h	See chapter 4.9.1
Oil change intervals	Not required	See chapter 7.2.9
Lubricants	Synthetic lubricant, NSF-approved (NOTOX)	See chapter 7.2.9
Type plate	Etched	

Performance data

n_1 [rpm]	1:1			1.5:1			2:1			3:1			4:1			5:1			6:1		
	n_2 [rpm]	P_{1N} [kW]	T_{2N} [Nm]	n_2 [rpm]	P_{1N} [kW]	T_{2N} [Nm]	n_2 [rpm]	P_{1N} [kW]	T_{2N} [Nm]	n_2 [rpm]	P_{1N} [kW]	T_{2N} [Nm]	n_2 [rpm]	P_{1N} [kW]	T_{2N} [Nm]	n_2 [rpm]	P_{1N} [kW]	T_{2N} [Nm]	n_2 [rpm]	P_{1N} [kW]	T_{2N} [Nm]
3000	3000	39.68	120	2000	24.91	113	1500	16.53	100	1000	12.12	110	750	8.51	103	600	6.61	100	500	5.18	94
2400	2400	37.04	140	1600	22.22	126	1200	14.68	111	800	11.46	130	600	7.34	111	480	5.56	105	400	4.58	104
1500	1500	26.78	162	1000	17.08	155	750	11.41	138	500	8.05	146	375	4.96	120	300	3.80	115	250	2.95	107
1000	1000	20.28	184	667	12.87	175	500	8.38	152	333	5.87	160	250	3.75	136	200	2.73	124	167	2.06	112
750	750	16.20	196	500	10.47	190	375	6.86	166	250	4.60	167	188	3.06	148	150	2.15	130	125	1.61	117
500	500	11.46	208	333	7.34	200	250	4.96	180	167	3.20	174	125	2.12	154	100	1.50	136	83	1.09	119
250	250	5.92	215	167	3.76	204	125	2.62	190	83	1.62	177	63	1.12	162	50	0.79	143	42	0.56	121
50	50	1.21	220	33	0.76	210	25	0.55	200	17	0.34	180	13	0.23	170	10	0.17	150	8	0.11	120
P_{1Nt} [kW]	9.0			9.0			9.0			9.0			9.0			9.0			9.0		
T_{2max} [Nm]	430			210			320			280			280			250			200		

The mass of the gearbox may deviate depending on the gear ratio.

Permissible radial force F_{r1} and axial force F_{a1} on shaft N_1

The permissible radial forces depend on torque, rotational speed and direction.

They must be calculated for the respective case of application. Please enquire these.

n_1 [rpm]	3000		1000		500		250		100		50	
T_2 [Nm]	F_r [N]	F_a [N]	F_r [N]	F_a [N]	F_r [N]	F_a [N]	F_r [N]	F_a [N]	F_r [N]	F_a [N]	F_r [N]	F_a [N]
< 140	700	350	870	435	1150	575	1370	685	1700	850	2000	1000
> 140	590	295	730	365	960	480	1140	570	1420	710	1670	835

Permissible radial force F_{r2} and axial force F_{a2} on shaft N_2

n_2 [rpm]	3000		1000		500		250		100		50	
T_2 [Nm]	F_r [N]	F_a [N]	F_r [N]	F_a [N]	F_r [N]	F_a [N]	F_r [N]	F_a [N]	F_r [N]	F_a [N]	F_r [N]	F_a [N]
< 140	1300	650	1700	850	2000	1000	2500	1250	3000	1500	3800	1900
> 140	1082	541	1420	710	1670	835	2080	1040	2500	1250	3170	1585

Inertia moments/mass

The mass of the gearbox may deviate depending on the gear ratio.

Model	Inertia moment [kgcm ²]						
	1:1	1.5:1	2:1	3:1	4:1	5:1	6:1
AO	26.2670	11.8569	8.6762	6.4356	1.8432	1.5320	1.3708
BO	36.0994	18.7513	12.2785	7.9547	2.6978	2.2113	1.8426
CO	36.0994	18.7513	12.2785	7.9547	2.6978	2.2113	1.8426
DO	37.0815	19.1878	12.5241	8.0639	2.7592	2.2506	1.8698
EON	32.6630	17.2240	11.4194	7.5729	2.4830	2.0739	1.7471
EOS	39.0643	20.0691	13.0198	8.2842	2.8831	2.3299	1.9249
FO	39.4005	17.6940	11.9596	7.8949	2.6641	2.0574	1.7356
GO	49.2329	24.7711	17.6713	12.9310	3.7202	3.2180	2.8486
HO	49.2329	24.7711	17.6713	12.9310	3.7202	3.2180	2.8486
JO	50.2150	25.2076	17.9169	13.0402	3.7816	3.2573	2.8758
KON	45.7965	23.2438	16.8122	12.5492	3.5054	3.0806	2.7531
KOS	52.1978	26.0889	18.4126	13.2605	3.9055	3.3366	2.9309

Mass
[kg]

19.0
18.5
18.5
19.0
18.0
18.7
23.0
22.7
22.7
23.2
22.2
22.9

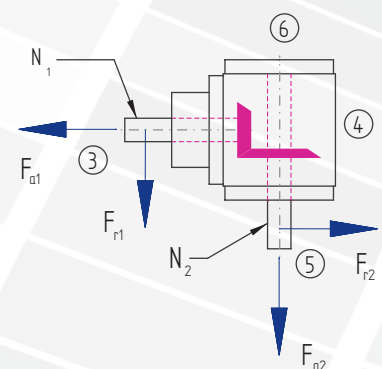

7.2.21 Type HDV 140 – Hygiene-design bevel gearboxes

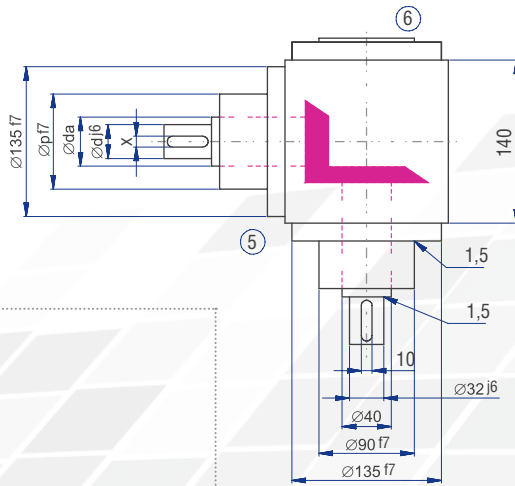
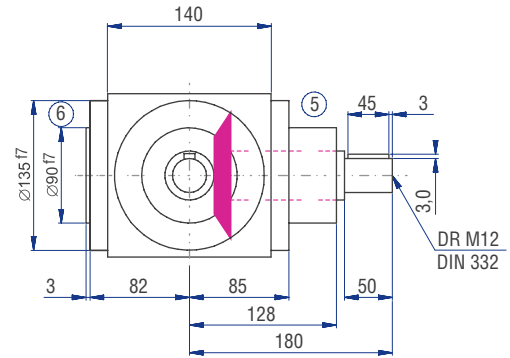
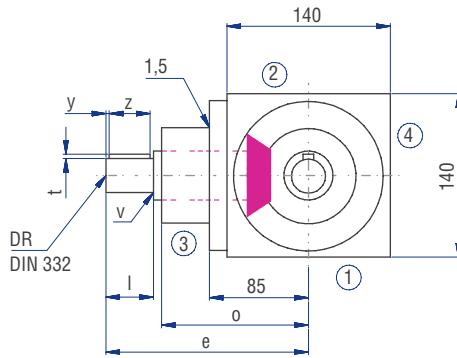
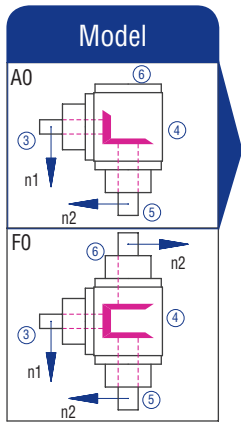

	Gear ratio						
	1:1	1.5:1	2:1	3:1	4:1	5:1	6:1
d [mm]	40	40	40	40	40	40	40
da [mm]	32	32	32	28	24	24	24
l [mm]	180	180	180	180	195	195	195
v [mm]	50	50	50	50	50	50	50
x [mm]	128	128	128	128	143	143	143
y [mm]	90	90	90	90	85	85	85
z [mm]	3	3	3	3	3	3	3
t [mm]	1.5	1.5	1.5	1	1	1	1
e [mm]	10	10	10	8	8	8	8
o [mm]	3	3	3	3	3	3	3
p [mm]	45	45	45	45	45	45	45
DR M	12	12	12	10	8	8	8

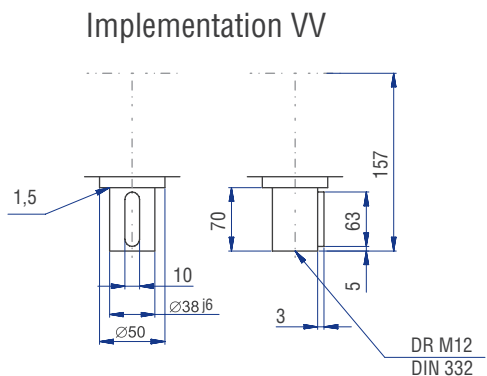
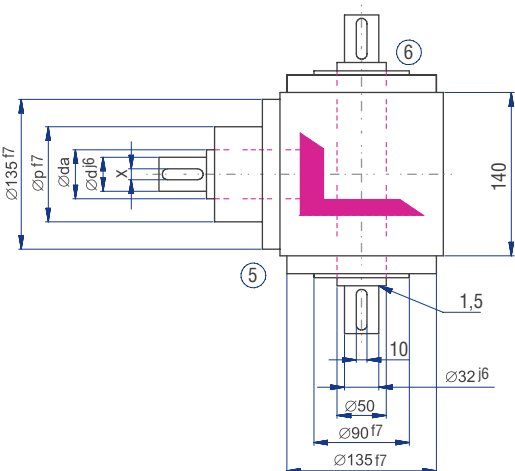
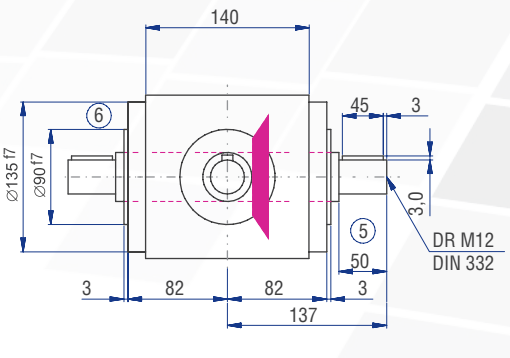
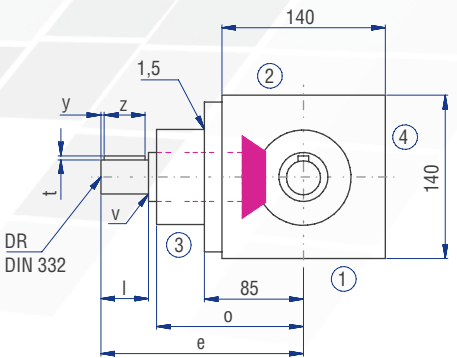
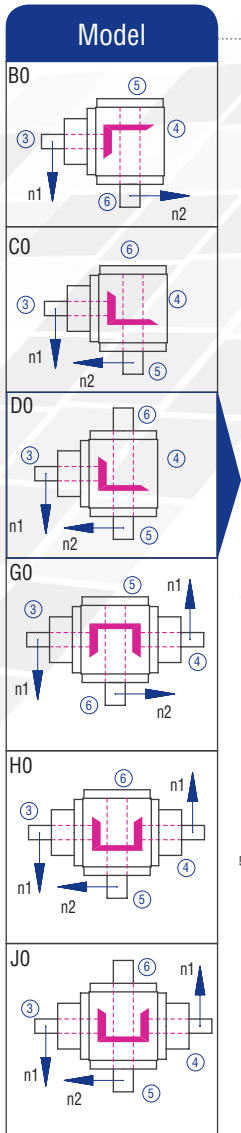

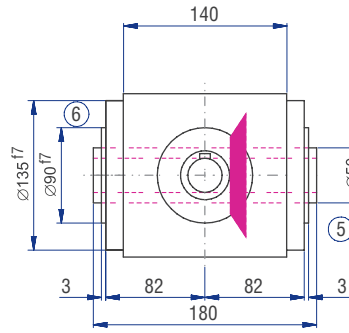
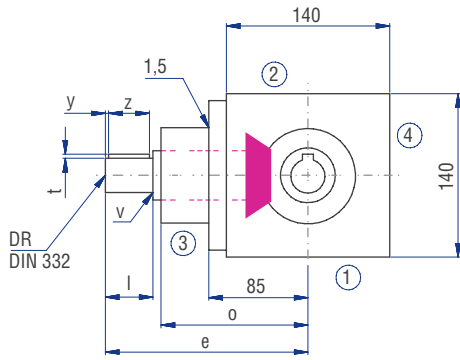

Implementation

