

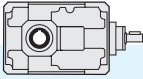

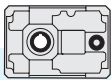

INDICE
INDEX
INHALTSVERZEICHNIS

1.0	GENERALITA'	GENERAL INFORMATION	ALLGEMEINES	2
1.1	Unità di misura	<i>Measurement units</i>	Maßeinheiten	2
1.2	Fattore di servizio	<i>Service factor</i>	Betriebsfaktor	2
1.3	Selezione	<i>Selection</i>	Wahl	4
1.4	Potenza termica	<i>Thermal power</i>	Thermische Leistung	5
1.5	Verifica del dispositivo antiritorno	<i>Check out of the backstop device</i>	Prüfung der Rücklauf Sperre	6
1.6	Lubrificazione	<i>Lubrication</i>	Ölschmierung	8
1.7	Installazione	<i>Installation</i>	Einbau	9
1.8	Rodaggio	<i>Running-in</i>	Einfahren	10
1.9	Manutenzione	<i>Maintenance</i>	Wartung	10
				
2.0	RIDUTTORI AD ASSI ORTOGONALI T	BEVEL HELICAL GEARBOX T	KEGELSTIRNRADGETRIEBE T	11
				
3.0	RIDUTTORI AD ASSI PARALLELI Z	PARALLEL SHAFT GEARBOX Z	PARALLELENGETRIEBE Z	45
				
4.0	RIDUTTORI PENDOLARI P	SHAFT-MOUNTED GEARBOX P	AUFSTECKGETRIEBE P	69
				
5.0	RIDUTTORI PENDOLARI M	SHAFT-MOUNTED GEARBOX M	AUFSTECKGETRIEBE M	85
				
6.0	RINVII ANGOLARI R	RIGHT ANGLE GEARBOX R	WINKELGETRIEBE R	95
				
7.0	RINVII ANGOLARI L	RIGHT ANGLE GEARBOX L	WINKELGETRIEBE L	111
				
8.0	RINVII ANGOLARI RL	RIGHT ANGLE GEARBOX RL	WINKELGETRIEBE RL	127
				
9.0	VARIATORI N	VARIATORS N	VERSTELLGETRIEBE N	135
				
10.0	VARIATORI UDL	VARIATORS UDL	VERSTELLGETRIEBE UDL	147
11.0	MOTORI ELETTRICI	ELECTRIC MOTORS	ELEKTROMOTOREN	153
12.0	CONDIZIONI GENERALI DI VENDITA	TERM AND CONDITIONS OF SALE	ALLGEMEINE VERKAUFSBEDINGUNGEN	157

1.0 GENERALITA'
1.0 GENERAL INFORMATION
1.0 ALLGEMEINES
1.1 Unità di misura
1.1 Measurement units
1.1 Maßeinheiten

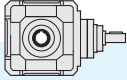
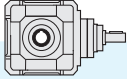
Tab. 1

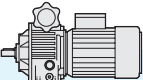
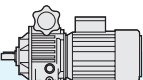
SIMBOLO SYMBOL SYMBOL	DEFINIZIONE	DEFINITION	BEZEICHNUNG	UNITA' DI MISURA MEASUREMENT UNIT MAßEINHEIT
Fr 1-2	Carico Radiale	<i>Radial load</i>	Radialbelastung	N
Fa 1-2	Carico Assiale	<i>Axial load</i>	Axialbelastung	N
	Dimensioni	<i>Dimensions</i>	Abmessungen	mm
FS	Fattore di servizio	<i>Service factor</i>	Betriebsfaktor	
kg	Massa	<i>Mass</i>	Masse	kg
T_{2M}	Momento torcente riduttore	<i>Gearbox torque</i>	Getriebe Drehmoment	Nm
T₂	Momento torcente motorid.	<i>Gearmotor torque</i>	Getriebemotor Drehmoment	Nm
P	Potenza motore	<i>Motor power</i>	Motor Leistung	kW
Pc	Potenza corretta	<i>Corrected power</i>	Verbesserte Leistung	kW
P1	Potenza motoriduttore	<i>Gearmotor power</i>	Getriebemotor Leistung	kW
P₁₀	Potenza termica	<i>Thermal power</i>	Thermische Leistung	kW
P'	Potenza richiesta in uscita	<i>Output power</i>	Erforderliche Abtriebsleistung	kW
RD	Rendimento dinamico	<i>Dynamic efficiency</i>	Dynamischer Wirkungsgrad	
in	Rapp. di trasm. nominale	<i>Rated reduction ratio</i>	Nennuntersetzung	
ir	Rapporto di trasmissione reale	<i>Actual reduction ratio</i>	Reelle Untersetzung	
n₁	Velocità albero entrata	<i>Input speed</i>	Antriebsdrehzahl	min⁻¹
n₂	Velocità albero uscita	<i>Output speed</i>	Abtriebsdrehzahl	min⁻¹
Tc	Temperatura ambiente	<i>Ambient temperature</i>	Umgebungstemperatur	°C
η	Rendimento	<i>Efficiency</i>	Wirkungsgrad	
IEC	Motori accoppiabili	<i>Motor options</i>	Passende Motoren	

1.2 Fattore di servizio
1.2 Service factor
1.2 Betriebsfaktor

Il fattore di servizio **FS** permette di qualificare, in prima approssimazione, la tipologia dell'applicazione tenendo conto della natura del carico (A, B, C), della durata di funzionamento h/gg (ore giornaliere) e del numero di avviamenti/ora. Il coefficiente così trovato dovrà essere uguale o inferiore al fattore di servizio del riduttore **FS'** dato dal rapporto fra la coppia nominale del riduttore **T_{2M}** indicata a catalogo e la coppia **T₂'** richiesta dall'applicazione.

*Service factor **FS** enables approximate qualification of the type of application, taking into account type of load (A,B,C), length of operation h/d (hours/day) and the number of starts-up/hour. The coefficient thus calculated must be equal to or lower than the gear unit service factor **FS'** which equals the ratio between **T_{2M}** (gear unit rated torque reported in the catalogue) and **T₂'** (torque required by the application).*

Der **FS** Betriebsfaktor ermöglicht die annähernde Bestimmung der Anwendungsart. Dabei werden Art der Last (A, B, C), Betriebsstunden pro Tag (S/T) und Anzahl der Starts pro Stunde berücksichtigt. Der so ermittelte Koeffizient sollte dem Betriebsfaktor **FS'**, der sich aus dem Verhältnis zwischen Nenndrehmoment des Getriebes **T_{2M}** (s. Katalog) und dem für die Anwendung erforderlichen Drehmoment **T₂'** ergibt, entweder entsprechen oder niedriger liegen.

$$FS' = \frac{T_{2M}}{T_2'} > FS$$

I valori di **FS** indicati nella tab. 2, sono relativi all'azionamento con motore elettrico; se utilizzato un motore a scoppio, si dovrà tenere conto di un fattore di moltiplicazione 1.3 se a più cilindri e 1.5 se monocilindro.

Se il motore elettrico applicato è autofrenante, considerare un numero di avviamenti doppio di quello effettivamente richiesto.

***FS** values reported in table 2 refer to a drive unit equipped with an electric motor. If an internal combustion engine is used, a multiplication factor of 1.3 must be applied for a several-cylinder engine, 1.5 for a single-cylinder engine.*

If the electric motor is self-braking, consider twice the number of starts-up than those actually required.

Die **FS** Werte, die in Tabelle 2 angegeben werden, beziehen sich auf den Antrieb mit Elektromotor; falls ein Explosionsmotor verwendet wird, ist ein Multiplikationsfaktor von 1.3 für Mehrzylindermotor und von 1.5 für Einzylindermotor zu berücksichtigen.

Falls der verwendete Elektromotor ein Bremsmotor ist, so ist die Zahl der tatsächlich erforderlichen Startvorgänge doppelt zu zählen.

Tab. 2

Classe di carico <i>Load class</i> Lastklasse	h/gg <i>h/d</i> St./Tag	N. AVVIAMENTI/ORA / N. START-UP/HOUR / ANZAHL DER STARTVORGÄNGE PRO STUNDE								
		2	4	8	16	32	63	125	250	500
A	4	0.8	0.8	0.9	0.9	1.0	1.1	1.1	1.2	1.2
	8	1.0	1.0	1.1	1.1	1.3	1.3	1.3	1.3	1.3
	16	1.3	1.3	1.3	1.3	1.5	1.5	1.5	1.5	1.5
	24	1.5	1.5	1.5	1.5	1.8	1.8	1.8	1.8	1.8
APPLICAZIONI / APPLICATIONS / ANWENDUNGEN										
Agitatori per liquidi puri Alimentatori per fornaci Alimentatori a disco Filtri di lavaggio con aria Generatori Pompe centrifughe Trasportatori con carico uniforme			<i>Pure liquid agitators</i> <i>Furnace feeders</i> <i>Disc feeders</i> <i>Air laundry filters</i> <i>Generators</i> <i>Centrifugal pumps</i> <i>Uniform load conveyors</i>			Rührwerke für reine Flüssigkeiten Beschickungsvorrichtungen für Brennöfen Telleraufgeber Spülluftfilter Generatoren Kreiselpumpen Förderer mit gleichmäßig verteilter Last				

Classe di carico <i>Load class</i> Lastklasse	h/gg <i>h/d</i> St./Tag	N. AVVIAMENTI/ORA / N. START-UP/HOUR / ANZAHL DER STARTVORGÄNGE PRO STUNDE								
		2	4	8	16	32	63	125	250	500
B	4	1.0	1.0	1.0	1.0	1.3	1.3	1.3	1.3	1.3
	8	1.3	1.3	1.3	1.3	1.5	1.5	1.5	1.5	1.5
	16	1.5	1.5	1.5	1.5	1.8	1.8	1.8	1.8	1.8
	24	1.8	1.8	1.8	1.8	2.2	2.2	2.2	2.2	2.2
APPLICAZIONI / APPLICATIONS / ANWENDUNGEN										
Agitatori per liquidi e solidi Alimentatori a nastro Argani con medio servizio Filtri con pietre e ghiaia Viti per espulsione acqua Flocculatori Filtri a vuoto Elevatori a tazze Gru			<i>Liquid and solid agitators</i> <i>Belt conveyors</i> <i>Medium service winches</i> <i>Stone and gravel filters</i> <i>Dewatering screws</i> <i>Flocculator</i> <i>Vacuum filters</i> <i>Bucket elevators</i> <i>Cranes</i>			Rührwerke für Flüssigkeiten und Feststoffe Bandförderer Mittlere Winden Filter mit Steinen/Kies Abwasserschnecken Flockvorrichtungen Vakuumfilter Becherwerke Kräne				

Classe di carico <i>Load class</i> Lastklasse	h/gg <i>h/d</i> St./Tag	N. AVVIAMENTI/ORA / N. START-UP/HOUR / ANZAHL DER STARTVORGÄNGE PRO STUNDE								
		2	4	8	16	32	63	125	250	500
C	4	1.3	1.3	1.3	1.3	1.5	1.5	1.5	1.5	1.5
	8	1.5	1.5	1.5	1.5	1.8	1.8	1.8	1.8	1.8
	16	1.8	1.8	1.8	1.8	2.2	2.2	2.2	2.2	2.2
	24	2.2	2.2	2.2	2.2	2.5	2.5	2.5	2.5	2.5
APPLICAZIONI / APPLICATIONS / ANWENDUNGEN										
Argani per servizio pesante Estrusori Calandre per gomma Presse per mattoni Piallatrici Mulini a sfera			<i>Heavy duty hoists</i> <i>Extruders</i> <i>Crusher rubber calenders</i> <i>Brick presses</i> <i>Planing machine</i> <i>Ball mills</i>			Winden für schwere Lasten Extruder Gummikalander Ziegelpressen Hobelmaschinen Kugelmühle				

1.3 Selezione

Determinare la potenza in entrata P' (in base alla coppia T_2 richiesta dall'applicazione) con la seguente formula:

1.3 Selection

Calculate input power P' (on the basis of the torque T_2 required by the application), using the following formula:

$$P' = \frac{T_2' \cdot n_2}{9550 \cdot \eta} \quad [\text{kW}]$$

1.3 Wahl

Bestimmen Sie die Antriebsleistung P' (je nach dem bei der Anwendung erforderlichen Drehmoment T_2) mit Hilfe der folgenden Formel:

Calcolare il rapporto di trasmissione con la relazione:

Calculate the transmission ratio with the following equation:

$$i_n = \frac{n_1}{n_2}$$

Berechnen Sie das Untersetzungsverhältnis mit Hilfe der Gleichung:

Scegliere il fattore di servizio FS dell'applicazione nella Tab. 2.

Select the service factor FS of the application in Table 2.

Wählen Sie den Betriebsfaktor FS der Anwendung aus der Tabelle 2 aus.

Scelta riduttore

A) $n_1 = 1400 \text{ min}^{-1}$

Si sceglierà nelle tabelle delle prestazioni dei riduttori un gruppo che in corrispondenza di un rapporto prossimo a quello calcolato ammetta una potenza:

Selecting a gearbox

A) $n_1 = 1400 \text{ min}^{-1}$

Consult the gear unit efficiency table; select a group whose ratio is close to the calculated ratio and which permits power:

Wahl des Getriebes

A) $n_1 = 1400 \text{ min}^{-1}$

Aus der Tabelle der Leistungen der Untersetzungsgetriebe wählt man eine Baugruppe aus, die ein ähnliches Untersetzungsverhältnis zu dem berechneten Wert aufweist und die die folgende Leistung zulässt:

$$P \geq P' \times \text{FS}$$

B) $n_1 \neq 1400 \text{ min}^{-1}$

Si dovrà effettuare la scelta come nel caso precedente però in base ad una potenza P_c corretta con i coefficienti riportati nelle tabelle relative ad ogni tipologia di riduttore verificando la relazione:

B) $n_1 \neq 1400 \text{ min}^{-1}$

Make the selection as described above but on the basis of power P_c corrected by the coefficients reported in the tables. The following equation should be checked out:

B) $n_1 \neq 1400 \text{ min}^{-1}$

Die Wahl wird wie im obigen Fall ausgeführt, allerdings auf der Basis einer Leistung P_c , die mit den Koeffizienten korrigiert wurde. Dabei ist das folgende Verhältnis zu überprüfen:

$$P_c \geq P' \times \text{FS}$$

Scelta del motoriduttore

C) $n_1 = 1400 \text{ min}^{-1}$ e $\text{FS} = 1$

Si cercherà nelle tabelle delle prestazioni dei motoriduttori un gruppo la cui potenza P_1 corrisponda alla P' calcolata.

D) $n_1 \neq 1400 \text{ min}^{-1}$ o se il fattore $\text{FS} \neq 1$

La scelta dovrà essere effettuata come al punto A) verificando che la grandezza del motore da installare sia compatibile con quelle ammesse dal riduttore (IEC); ovviamente la potenza installata dovrà corrispondere al valore P' richiesto.

Selecting a gearmotor

C) $n_1 = 1400 \text{ min}^{-1}$ and $\text{FS} = 1$

Consult the gear motor efficiency table and select a group having power P_1 corresponding to calculated P' .

D) $n_1 \neq 1400 \text{ min}^{-1}$ or $\text{FS} \neq 1$

Follow the instructions at point A), checking that the size of the motor to be installed is compatible with the gear unit (IEC); obviously, installed power must correspond to the required P' value.

Wahl des Getriebemotors

C) $n_1 = 1400 \text{ min}^{-1}$ und $\text{FS} = 1$

In den Leistungstabellen der Getriebemotoren sucht man eine Baugruppe, deren Leistung P_1 der berechneten Leistung P' entspricht.

D) $n_1 \neq 1400 \text{ min}^{-1}$ oder $\text{FS} \neq 1$

Die Auswahl wird wie unter A) getroffen, wobei zu überprüfen ist, ob die Größe des zu installierenden Motors mit dem Untersetzungsgetriebe kompatibel ist (IEC); selbstverständlich muß die Einbauleistung dem erforderlichen Wert P' entsprechen.

Verifiche

Verificare che i carichi radiali agenti sugli alberi rientrino nei valori ammissibili riportati nelle relative tabelle.

Tali valori (F_{R2}) si riferiscono a carichi che agiscono a metà sporgenza dell'albero, per cui se il punto di applicazione è diverso, è necessario effettuare il calcolo dei nuovi valori ammissibili alla distanza (y) desiderata.

Analogamente a quanto precisato sopra, anche i carichi assiali dovranno essere oggetto di verifica confrontandoli con i valori delle relative tabelle.

Sovraccarichi

Durante il normale funzionamento del riduttore è ammesso un sovraccarico istantaneo di emergenza pari al 100% della coppia indicata T_2 .

Se si temono sovraccarichi frequenti o superiori è indispensabile prevedere degli opportuni dispositivi per la limitazione della coppia.

Ingranaggi

Il calcolo a durata ed a fatica degli ingranaggi viene eseguito secondo la norma ISO 6336 e ISO 10300, considerando l'impiego di olio sintetico.

Check-list

Check that the radial loads on the shafts fall within to the admissible values reported in the relative tables.

Reported values (F_{R2} refer to loads which affect the shaft at the half-way point of its projection; if the point of application is different, it is necessary to calculate the new admissible values at the desired distance (y).

In keeping with the above guidelines, axial loads should also be checked against the values reported in the relative tables.

Overloads

An emergency momentary overload up to 100% of T_2 torque is allowed during standard operation of the gearbox.

Should frequent or higher overloads be expected, it is necessary to install torque limiting devices.

Gears

Life and fatigue of the gears are calculated in compliance with ISO 6336 and ISO 10300. Calculations refer to utilization of synthetic oil

Überprüfungen

Es ist zu ueberpruefen, ob die, dass die auf die Wellen wirkenden Radiallasten unter den in der Tabellen angegebenen zulässigen Werten fallen.

Werte beziehen sich auf Lasten, die in der F_{R2} Mitte der herausragenden Welle wirken; bei verschiedenem Ansatzpunkt ist es daher erforderlich, die neuen, beim gewünschten Abstand (y) zulässigen Werte zu berechnen.

Ähnlich wie oben, müssen auch Axialbelastungen überprüft werden, indem man sie mit den Werten der jeweiligen Tabellen vergleicht.

Überbelastungen

Eine augenblickliche Notfall-Überbelastung zu 100% des T_2 Drehmoments darf während Getriebestandardbetrieb eintreten.

Falls häufige und höhere Überlastungen erwartet werden, sind die entsprechenden Vorrichtungen zur Begrenzung des Drehmoments anzubringen.

Räderwerk

Dauer und Belastung werden gemäß ISO 6336 und ISO 10300 berechnet. Dabei wird die Anwendung von synthetischem Oel berücksichtigt

1.4 Potenza Termica

Nelle tabelle riportate nelle sezioni relative ad ogni tipologia di riduttore sono indicati i valori della potenza termica nominale P_{t0} (kW). Tale valore rappresenta la potenza massima applicabile all'entrata del riduttore, in servizio continuo a temperatura ambiente di 30°C, così che la temperatura dell'olio non oltrepassi il valore di 95°C, valore massimo ammesso nel caso di prodotti standard.

Il valore di P_{t0} non deve essere preso in considerazione se il funzionamento è continuo per un massimo di 1.5 ore seguito da pause di durata sufficiente (circa 1 – 2 ore) a ristabilire nel riduttore la temperatura ambiente.

I valori di P_{t0} devono essere corretti tramite i seguenti coefficienti, così da considerare le reali condizioni di funzionamento, ottenendo i valori di potenza termica corretta P_{tc} .

1.4 Thermal power

The different sections dedicated to each type of gearbox contain tables reporting the values of rated thermal power P_{t0} (kW). Reported values correspond to the maximum admissible power at gearbox input, on continuous duty and with ambient temperature of 30°C, so that oil temperature does not exceed 95°C, which is the max. admissible value for standard products.

P_{t0} value should not be taken into account in case of continuous duty for max. 1.5 hours followed by pauses which are long enough to bring the gearbox back to ambient temperature (roughly 1 – 2 hours).

In order to comply with the actual operating conditions, P_{t0} values should be corrected with the following coefficients, thus obtaining the values of corrected thermal power P_{tc} .

1.4 Thermische Leistung

Für jeden Getriebetyp gibt es Tabellen, die die Nennwerte der thermischen Leistung P_{t0} (kW) angeben. Die angegebenen Werte stellen die max. anwendbare Antriebsleistung der Getriebe im Dauerbetrieb mit einer Umgebungstemperatur von max. 30°C dar, sodass die Öltemperatur unter 95°C bleibt (max. Wert für Standardprodukte).

P_{t0} Wert darf nicht betrachtet werden, falls Dauerbetrieb max. 1.5 Stunden dauert und von Stillstand gefolgt wird, der lang genug ist, damit das Getriebe zur Umgebungstemperatur zurück kommt. (ungefähr 1 – 2 Stunden).

P_{t0} Werte sollen durch die folgenden Koeffizienten verbessert werden, Damit die realen Betriebsbedingungen wirklich in Betracht gezogen werden. Mit der folgenden Formel erhält man die Werte der korrekten thermischen Leistung P_{tc} .

$$P_{tc} = P_{t0} \cdot ft \cdot fv \cdot fu \text{ (kW)}$$

Dove:
ft = coefficiente di temperatura (v. tab. 3)

Where:
ft = temperature coefficient (see table 3)

Dabei ist:
ft = Temperaturkoeffizient (siehe Tabelle 3)

Tab. 3

Tc (°C)	0	5	10	15	20	25	30	35	40	45	50
ft	1.46	1.38	1.31	1.23	1.15	1.1	1	0.92	0.85	0.77	0.69

(Dove Tc (°C) è la temperatura ambiente)

(Tc (°C) is the ambient temperature)

(Tc (°C) ist die Umgebungstemperatur)

fv = coefficiente di ventilazione
fv = 1.45 con ventilazione forzata efficace con ventola dedicata
fv = 1.25 con ventilazione forzata secondaria ad altri dispositivi (pulegge, ventole motore, ecc.)
fv = 1 refrigerazione naturale (situazione standard)
fv = 0.5 in ambiente chiuso e ristretto (carter)

fv = cooling coefficient
fv = 1.45 forced cooling with specific fan
fv = 1.25 forced cooling secondary to other devices (pulleys, motor fans, etc)
fv = 1 natural cooling (standard)
fv = 0.5 in a closed and narrow environment

fv = Luftkühlungskoeffizient
fv = 1.45 Drucklüftung mit Sonderlüfterrad
fv = 1.25 Drucklüftung nebensächlich zu anderen Vorrichtungen (Scheiben, Motorlüfterräder, usw.)
fv = 1 natürliche Lüftung (Standard)
fv = 0.5 in engem und geschlossenem Raum

fu = coefficiente di utilizzo (v. tab. 4)

fu = utilization coefficient (see table 4)

fu = Verwendungskoeffizient (siehe Tabelle 4)

Tab. 4

Dt (min)	10	20	30	40	50	60
fu	1.6	1.35	1.2	1.1	1.05	1

Dove Dt sono i minuti di funzionamento in un'ora

Dt is minutes of operation per hour

Dt steht für Betriebsminuten pro Stunde

1.5 Verifica del dispositivo antiritorno

Dopo aver correttamente selezionato il riduttore, occorre verificare se il valore del momento torcente T_{2M} max garantito all'asse uscita del riduttore dal dispositivo antiritorno, considerate le reali condizioni di esercizio, è sufficiente a garantire il buon funzionamento dell'applicazione. Deve pertanto essere verificata la seguente relazione:

1.5 Check of back stop device

After having selected the gearbox it is necessary to check whether the max. output torque T_{2M} max guaranteed by the backstop device, in view of the actual operating conditions, is sufficient to ensure the good functioning of the application. The following equation has to be checked out:

1.5 Prüfung der Rücklaufsperr

Nach der Wahl des Getriebes muss sichergestellt werden, dass das von der Rücklaufsperr garantierte Abtriebsdrehmoment T_{2M} max hoch genug ist, damit der korrekte Ablauf der Applikation unter Berücksichtigung der wirklichen Betriebsbedingungen gewährleistet wird. Die folgende Relation ist festzustellen:

$$T_{2M} \max = T_{2NOM} \cdot fc \cdot fa \cdot ft \quad (1)$$

Dove:
 T_{2NOM} [Nm]: è il momento torcente che deve essere garantito all'asse uscita del riduttore, nell'istante in cui viene interrotta la trasmissione del moto, affinché sia soddisfatta la condizione di irreversibilità del moto. T_{2NOM} dipende dalle specifiche dell'applicazione e deve essere valutato volta per volta.

fc: fattore di carico
fc=1 in caso di funzionamento regolare
fc=1.3 in caso di funzionamento con urti moderati
fc=1.8 in caso di funzionamento con forti urti

Where:
 T_{2NOM} [Nm]: is the torque that must be guaranteed at gearbox output when motion transmission is stopped, in order that motion irreversibility is ensured. T_{2NOM} depends on application features and should be assessed each time.

fc: load factor
fc=1 in case of standard operation
fc=1.3 in case of operation with moderate shocks
fc=1.8 in case of operation with heavy shocks

Dabei ist:
 T_{2NOM} [Nm]: Drehmoment, das am Getriebebetrieb garantiert werden muss, wenn die Übertragung der Bewegung stoppt, damit Irreversibilität gewährleistet wird. T_{2NOM} hängt ab von den Merkmalen der Applikation, d. h. T_{2NOM} muss jeweils bewertet werden.

fc: Last-Faktor
fc=1 bei Standardbetrieb
fc=1.3 bei Betrieb mit mäßigen Stößen
fc=1.8 bei Betrieb mit starken Stößen

NOTA:

Per funzionamento regolare si intende il caso in cui il dispositivo antiritorno, in attesa della ripresa della normale attività del riduttore, mantiene la macchina ferma. Se invece, nel momento in cui il dispositivo antiritorno è azionato (quindi il riduttore è fermo), il carico in uscita aumenta di intensità si possono avere degli urti (moderati o forti).

NOTE:

By standard running we mean that the back stop device keeps the machine stationary, whilst awaiting the restart of the gearbox operation. On the contrary in case the back stop device is enabled (motionless gearbox) and the output load gets heavier, moderate or heavy shocks might occur.

ANMERKUNG:

Im Standardbetrieb wird der Abtrieb bei einem Maschinenstopp durch die Rücklaufsperr blockiert. Ein erneuter Start löst die Rücklaufsperr wieder. Treten im Stillstand mässige oder starke Laststösse auf, müssen diese bei der Getriebeauslegung berücksichtigt werden.

fa: fattore di applicazione, ricavabile dalla seguente tabella (tab. 5) in funzione del numero di inserzioni/ora e dal numero di ore di funzionamento al giorno del riduttore

fa: application factor, as shown in the following table (tab. 5), depending on the number of backstop device insertions per hour and the number of gearbox operating hours per day.

fa: Anwendungsfaktor, wie es in der folgenden Tabelle (Tab.5) angegeben wird. Der Anwendungsfaktor hängt von der Zahl der Einschaltungen der Rücklaufsperrung pro Stunde und von Betriebsstunden des Getriebes pro Tag ab.

Tab. 5

h/gg - h/d - St./Tag	n° INSERZIONI / h - INSERTIONS / H - NR. EINSCHALTUNGEN / STUNDE					
	2	4	8	16	32	63
8	1	1	1.1	1.2	1.3	1.4
16	1.3	1.3	1.4	1.5	1.6	1.7
24	1.5	1.5	1.6	1.7	1.8	1.9

ft: fattore di temperatura ricavabile dalla seguente tabella (tab.6) in funzione della temperatura ambiente di funzionamento.

ft: temperature factor, as shown in the following table (tab. 6) depending on ambient temperature during gearbox operation.

ft: Temperaturfaktor, wie es in der folgenden Tabelle (Tab.6) angegeben wird. Der Temperaturfaktor hängt von der Umgebungstemperatur während des Getriebebetriebs ab.

Tab. 6

Tamb (°C)	-20°	-10°	0°	10°	20°	30°	40°	50°
ft	1.2	1.15	1.1	1.05	1	1.03	1.05	1.10

Se la relazione (1) a pag. 6 non risulta essere verificata si prenda in considerazione la possibilità o di variare il rapporto di riduzione, individuando una alternativa migliore, o di passare alle grandezze di riduttori successive.

If the result of the calculation does not correspond to the equation (1) at page 6, either the ratio has to be modified or a bigger size of gearbox has to be selected.

Falls das Resultat nicht der Relation (1) entspricht (Seite 6), muss entweder das Untersetzungsverhältnis oder die Größe des Getriebes geändert werden.

Nel caso in cui il riduttore, provvisto di dispositivo antiritorno, si trovi ad operare ad una temperatura ambiente minore di 0°C il riduttore può essere fornito, a seconda del rapporto di riduzione, in esecuzione speciale (con camera stagna) così da migliorare il funzionamento del dispositivo. Per quanto riguarda quest'ultima soluzione si contatti il servizio tecnico Tramec.

If the ambient temperature is below 0°C, the gearbox with backstop device can be supplied in the special execution (with tight chamber) which improves the functioning of the backstop device. Please contact Tramec Technical Dept. for further information.

Liegt die Umgebungstemperatur unter 0°C, wird empfohlen, die Sonderausführung des Getriebes (mit Dichtkammer) zu benutzen, damit die Rücklaufsperrung am besten funktioniert. Für weitere Auskünfte darüber soll man sich mit Tramec technischen Büro in Verbindung setzen.

1.6 Lubrificazione

I cuscinetti dell'albero veloce vengono sempre lubrificati con grasso a base sintetica; altri cuscinetti vengono lubrificati solo se la posizione di montaggio non ne garantisce la corretta lubrificazione.

Una scelta oculata del tipo di lubrificante, in funzione delle condizioni operative e ambientali, consente ai riduttori di raggiungere le prestazioni ottimali. Le prestazioni dei riduttori indicate nelle tabelle dei dati tecnici sono state calcolate considerando l'impiego di olio sintetico.

VISCOSITA'

E'uno dei parametri più importanti da considerare nella scelta di un olio ed è influenzabile da diversi parametri quali velocità, temperatura. Riportiamo sinteticamente le valutazioni generali per la scelta della giusta viscosità:

Viscosità alta

Usare per basse velocità di rotazione e/o temperature alte. (Una viscosità troppo bassa in queste condizioni operative causa una usura precoce).

Viscosità bassa

Usare per alte velocità di rotazione e/o temperature basse. (Una viscosità troppo elevata provoca diminuzione del rendimento e surriscaldamento).

ADDITIVI

In tutti gli oli minerali sono contenuti degli additivi antiusura, EP (più o meno energici), antiossidanti ed antischiuma. E' opportuno assicurarsi che essi siano blandi e non aggressivi nei confronti delle guarnizioni.

BASE DELL'OLIO

Può essere minerale o sintetica. L'olio sintetico, compensa il costo più elevato con una serie di vantaggi:

- a) minor coefficiente d'attrito (quindi migliore rendimento)
- b) migliore stabilità nel tempo (possibile lubrificazione a vita)
- c) migliore indice di viscosità (migliore adattabilità alle varie temperature).

L'olio a base minerale come vantaggi ha il minore costo e un migliore comportamento in rodaggio.

1.6 Lubrication

The bearings mounted on the input shaft are supplied with grease, synthetic base; the other bearings are lubricated only if the mounting position does not assure a correct lubrication.

Choose the lubricant according to operating and ambient conditions in order to ensure high gear unit performance. Performance data, as shown in the specifications tables, refer to utilization of synthetic oil.

VISCOSITY

It is the most important parameter to be considered when selecting an oil; it depends on various factors such as speed and temperature. Following are general guidelines for choosing the correct viscosity:

High viscosity

To be used for low rotation speed and/or high temperatures. (Under these operating conditions a low viscosity causes premature wear).

Low viscosity

To be used for high rotation speed and/or low temperatures. (High viscosity reduces efficiency and causes overheating).

ADDITIVES

All mineral oils contain additives to protect against wear, EP (more or less strong), anti-oxidizing and anti-frothing. It is advisable to make sure that the action of such additives is bland and not too aggressive on the seals.

OIL BASE

May be mineral or synthetic. Synthetic oil compensates for the higher cost with a series of advantages :

- a) *lower friction coefficient (consequently improved efficiency)*
- b) *better stability over time (possible life lubrication)*
- c) *better viscosity index (more adaptable to various temperatures).*

Mineral-base oils offer the advantages of costing less and performing better during the running-in period.

1.6 Ölschmierung

Die Kugellager auf der Eingangswelle werden immer mit synthetischem Fett geliefert. Falls die Montage keine korrekte Schmierung gewährleistet, dann werden die restlichen Lager mit Schmiermittel geliefert.

Das Untersetzungsgetriebe wird optimal arbeiten, wenn das richtige Schmiermittel je nach Betriebs- und Umgebungsbedingungen sorgfältig ausgewählt wird. Daten über Getriebeleistung, wie es in den Tabellen der technischen Daten angegeben wird, beziehen sich auf Schmierung mit synthetischem Öl.

VISKOSITÄT

Die Viskosität ist eines der wichtigsten Merkmale, die bei der Auswahl des richtigen Öls zu beachten sind; sie wird von verschiedenen Parametern wie Geschwindigkeit und Temperatur beeinflusst. Im folgenden fassen wir die wichtigsten allgemeinen Hinweise für die Wahl der richtigen Viskosität zusammen:

Hohe Viskosität

Geeignet für niedrige Drehzahlen bzw. hohe Temperaturen. (Eine zu geringe Viskosität verursacht unter diesen Betriebsbedingungen frühen Verschleiß).

Geringe Viskosität

Geeignet für hohe Drehzahlen bzw. niedrige Temperaturen. (Eine zu hohe Viskosität führt in diesem Fall zu einer Verringerung des Wirkungsgrades und zur Überhitzung).

ZUSAETZE















Alle Mineralöle enthalten Antiverschleiß-Zusätze, EP (mehr oder weniger stark), Oxydationsschutzmittel und Mittel gegen Schaumbildung. Es soll sichergestellt werden, daß diese Zusätze schwach sind und die Dichtungen nicht angreifen.

ÖLGRUNDLAGE

Es kann sich dabei um Mineralöl oder synthetisches Öl handeln. Synthetisches Öl ist kostenintensiver, bietet jedoch viele Vorteile:

- a) geringerer Reibungskoeffizient (besserer Wirkungsgrad)
- b) höhere Stabilität über lange Zeit (lebenslange Schmierung möglich)
- c) besserer Viskositätsindex (passt sich besser an Temperaturschwankungen an).

Die Vorteile von Mineralöl sind die niedrigeren Kosten und das bessere Einfahrverhalten.

ISO VG	OLIO MINERALE / MINERAL OIL / MINERALE			OLIO SINTETICO / SYNTHETIC OIL / SYNTETISCHES ÖL					
	460	320	220	460	320	220	150		
Temperatura ambiente Amb. Temp. Tc (°C) Umgebungstemperatur	5° a 45°	0° a 40°	-5° a 35°	-15° a 60°	-20 a 50°	-25° a 45°	-30° a 40°		
FORNITORE / MANUFACTURER / HERSTELLER	MINERALE / MINERAL / MINERAL								
	SHELL		Omala OIL 460	Omala OIL 320	Omala OIL 220				
	BP		Energol GRXP 460	Energol GRXP 320	Energol GRXP 220				
	TEXACO		Meropa 460	Meropa 320	Meropa 220				
	CASTROL		Alpha SP 460	Alpha SP 320	Alpha SP 220				
	KLUBER		Lamora 460	Lamora 320	Lamora 220				
	MOBIL		Mobilgear 634	Mobilgear 632	Mobilgear 630				
	Tecnologia PAG (polialcoliglicoli) / PAG Technology (polyalkyleneglycol) / PAG (Polyalkylglikole)								
	SHELL					Omala S4 WE 460	Omala S4 WE 320	Omala S4 WE 220	Omala S4 WE 150
	BP					Energol SGXP460	Energol SGXP320	Energol SGXP220	Enersyn SG 150
	TEXACO					Synlube CLP 460	Synlube CLP 320	Synlube CLP 220	
	AGIP						Agip Blasias S 320	Agip Blasias S 220	Agip Blasias S 150
	Tecnologia PAO (polialcoliolefini) / PAO Technology (polialphaolefin) / PAO (Polyalphaolefine)								
	SHELL					Omala OIL RL/HD 460	Omala OIL RL/HD 320	Omala OIL RL/HD 220	Omala OIL RL/HD 150
	CASTROL					Alpha Synt 460	Alpha Synt 320	Alpha Synt 220	Alpha Synt 150
	KLUBER					Synteso D460 EP	Synteso D320 EP	Synteso D220 EP	Synteso D150 EP
MOBIL					SHC 634	SHC 632	SHC 630	SHC 629	

1.7 Installazione

Montare il riduttore in modo tale da eliminare qualsiasi vibrazione.

Curare particolarmente l'allineamento del riduttore con il motore e la macchina da comandare interponendo dove è possibile giunti elastici od autoallineanti.

Quando il riduttore è sottoposto a sovraccarichi prolungati, urti o pericoli di bloccaggio, installare salvamotori, limitatori di coppia, giunti idraulici od altri dispositivi similari.

Fare attenzione a non superare i valori consentiti di carico radiale ed assiale che agiscono sugli alberi veloce e lento.

Assicurarsi che gli organi da montare sui riduttori siano lavorati con tolleranza **ALBERO ISO h6 FORO ISO H7.**

1.7 Installation

Install the gearbox so that any vibration is eliminated.

Take special care with the alignment between the gear units, the motor and the driven machine, fitting flexible or self adjusting couplings wherever possible.

If the gearbox is subject to prolonged overloads, shocks or possible jamming, fit overload cutouts, torque limiters, hydraulic couplings or other similar devices.

Do not exceed allowed radial and axial loads on the input and output shafts.

*Ensure that the components to be fitted on the gear units are machined with tolerance **SHAFT ISO h6 HOLE ISO H7.***

1.7 Einbau

Das Getriebe ist so zu montieren, daß Schwingungen ausgeschaltet werden.

Insbesondere ist auf die Fluchtung des Getriebes zum Motor und zur Maschine zu achten, wo möglich sind elastische oder selbstfluchtende Kupplungen anzubringen.

Wenn das Getriebe anhaltenden Überlasten, Schlägen oder Blockierungsgefahr ausgesetzt ist, sind Motorschalter, Drehmomentbegrenzer, hydraulische Kupplungen oder ähnliche Vorrichtungen anzubringen. Achten sie darauf, dass die zulässigen Radial- und Axialbelastungen an Antriebs- und Abtriebswelle nicht überschritten werden.

Achten Sie darauf, dass die am Getriebe montierten Elemente mit folgenden Toleranzen bearbeitet sind: **WELLE ISO h6, BOHRUNG ISO H7.**

Prima di effettuare il montaggio pulire e lubrificare le superfici al fine di evitare il pericolo di grippaggio e l'ossidazione da contatto.

Before assembling, clean and lubricate the surfaces to prevent seizure and contact oxidation.

Vor der Montage sind die Flächen zu reinigen und zu schmieren, um Festfressen bzw. Kontaktoxidation zu vermeiden.

Il montaggio va effettuato con l'ausilio di tiranti ed estrattori utilizzando il foro filettato posto in testa alle estremità degli alberi.

Assembly is to be carried out with the aid of tie-rods and extractors, using the threaded hole at the shaft ends.

Die Montage erfolgt mit Hilfe von Zugstangen und Ausziehvorrichtungen unter Verwendung der Gewindebohrung vorn an den Wellenenden.

Durante la verniciatura si consiglia di proteggere il bordo esterno degli anelli di tenuta per evitare che la vernice ne essichi la gomma pregiudicando la tenuta del paraolio stesso.

When painting, protect the outside edge of the oil seals to prevent the paint from drying the rubber and impairing sealing properties.

Während des Lackierens sollte der Außenrand der Dichtungsringe geschützt werden, um zu vermeiden, daß der Lack den Gummi austrocknet, was die Dichtungen beeinträchtigen könnte.

Prima della messa in funzione della macchina accertarsi che la quantità di lubrificante e la posizione dei tappi di livello e sfiato siano conformi alla posizione di montaggio del riduttore e che la viscosità del lubrificante sia adeguata al tipo di carico.

Before starting up the machine, check that the amount of lubricant and the position of filler and breather plugs are correct for the gear unit mounting position and that the lubricant viscosity is appropriate for the type of load.

Bevor die Maschine in Betrieb genommen wird, ist sicherzustellen, daß sowohl die Schmiermittelmenge als auch die Position der Ölstand- und der Entlüftungsschraube der Montageposition des Getriebes entsprechen und daß die Schmiermittelviskosität der Belastungsart entspricht.

Se il riduttore viene installato all'aperto si consiglia l'utilizzo del tappo di sfiato con valvola.

If the gearbox is installed outdoors, we recommend the use of the breather plug with valve.

Die Anwendung einer Entlüftungsschraube mit Ventil wird empfohlen, wenn das Getriebe im Freien eingebaut wird.

Tutti i riduttori e motoriduttori citati nel presente manuale sono destinati ad un impiego industriale con temperatura ambiente da -20°C a +40°C ad una altitudine max di 1000 m slm.

All reducers and gear motors mentioned in this catalog are intended for industrial use and operation at a ambient temperature between -20°C and +40°C, at an altitude of max. 1000 m above sea level.

Alle im vorliegenden Katalog angegebenen Getriebe und Getriebemotoren sind für industriellen Einsatz in einer Umgebungstemperatur von -20°C bis +40°C und in einer max. Höhe von 1000 m über dem Meeresspiegel vorgesehen.

Per tutte le altre avvertenze consultare il manuale di "uso e manutenzione" scaricabile dal sito www.tramec.it

For all other instructions check the "Use and Maintenance Manual" which can be downloaded from our web site www.tramec.it

Für weitere Anweisungen laden Sie die "Betriebs- und Instandhaltungsanweisung" aus unsere Webseite www.tramec.it herunter.

1.8 Rodaggio

1.8 Running-in

1.8 Einfahren

Si consiglia di incrementare gradualmente nel tempo la potenza trasmessa oppure limitare il momento torcente resistente della macchina da comandare per le prime ore di funzionamento.

Increase the transmitted power gradually or limit the resistant torque of the driven machine for the first few operating hours.

Es ist ratsam, die Leistung nur allmählich zu steigern oder das Widerstandsdrehmoment der Maschine in den ersten Betriebsstunden zu begrenzen.

1.9 Manutenzione

1.9 Maintenance

1.9 Wartung

Per i riduttori lubrificati con olio minerale dopo le prime 500 - 1000 ore di funzionamento sostituire l'olio effettuando, se possibile, un accurato lavaggio interno del riduttore.

Gear units lubricated with mineral oil, change the oil after the first 500 - 1000 operating hours and if possible thoroughly flush the inside of the gearbox.

Bei mit Mineralöl geschmierten Getrieben ist nach den ersten 500 bis 1000 Betriebsstunden ein Ölwechsel durchzuführen, dabei sollte das Getriebeinnere möglichst ausgespült werden.

Controllare periodicamente il livello del lubrificante ed effettuare il cambio dopo 4000 ore di funzionamento.

Check the lubricant level regularly and change after 4000 operating hours. If synthetic oil is used the oil change may take place after 12500 running hours.

Von Zeit zu Zeit ist der Ölstand zu prüfen, alle 4000 Betriebsstunden sollte ein Ölwechsel stattfinden.

Se è utilizzato olio sintetico il cambio può essere effettuato dopo 12500 ore di funzionamento.

When the gearbox is left unused in a highly humid environment fill it completely with oil.

Bei Verwendung von Synthetiköl kann der Ölwechsel alle 12500 Betriebsstunden erfolgen.

Quando il riduttore resta per lungo tempo inattivo in un ambiente con una elevata percentuale di umidità si consiglia di riempirlo completamente di olio.

Importantly the oil must be returned to the operating level before the unit is used again.

Wenn das Getriebe lange Zeit in einem Raum mit hoher Luftfeuchtigkeit stillliegt, ist es ratsam, es ganz mit Öl zu füllen.

Naturalmente al momento della successiva messa in funzione sarà necessario ripristinare il livello del lubrificante.

Wird es danach wieder in Betrieb genommen, so ist natürlich vorher der richtige Ölstand wiederherzustellen.

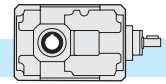

2.0

RIDUTTORE AD ASSI ORTOGONALI

BEVEL HELICAL GEARBOX

KEGELSTIRNRADGETRIEBE

2.1	Caratteristiche	<i>Characteristics</i>	Merkmale	12
2.2	Designazione	<i>Designation</i>	Bezeichnung	13
2.3	Sensi di rotazione alberi	<i>Direction of shaft rotation</i>	Drehrichtungen der Wellen	14
2.4	Entrata supplementare	<i>Additional input</i>	Zusatzantrieb	14
2.5	Rendimento	<i>Efficiency</i>	Wirkungsgrad	14
2.6	Velocità in entrata	<i>Input speed</i>	Antriebsdrehzahl	15
2.7	Potenza termica	<i>Thermal power</i>	Thermische Leistung	15
2.8	Dati tecnici	<i>Technical data</i>	Technische Daten	16
2.9	Momenti d'inerzia	<i>Moments of inertia</i>	Trägheitsmoment	18
2.10	Dimensioni	<i>Dimensions</i>	Abmessungen	25
2.11	Accessori	<i>Accessories</i>	Zubehör	32
2.12	Giochi angolari	<i>Angular backlash</i>	Winkelspiel	36
2.13	Lubrificazione	<i>Lubrication</i>	Schmierung	36
2.14	Carichi radiali e assiali	<i>Radial and axial loads</i>	Radial- und Axialbelastungen	38
2.15	Lista parti di ricambio	<i>Spare parts list</i>	Ersatzteilliste	40

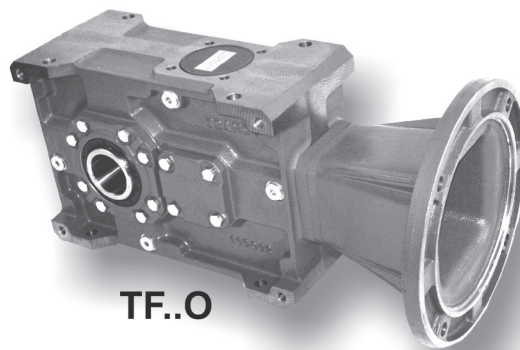

TF..O

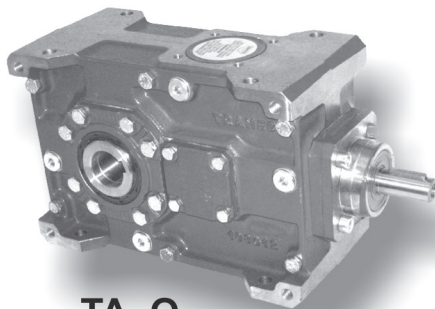

TA..O

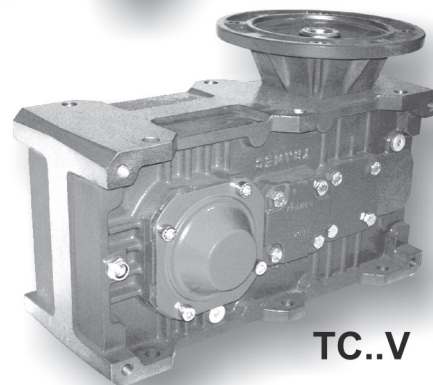

TC..V

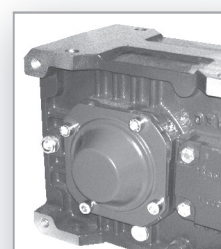
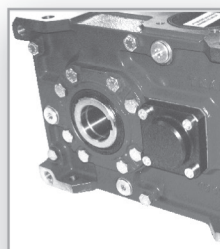
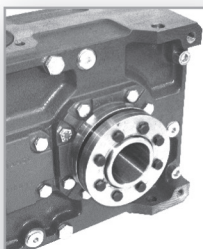

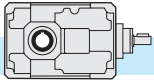

2.1 Caratteristiche

- Costruiti in 10 grandezze a 2 riduzioni e in 9 grandezze a 3 riduzioni.
- Sono previsti tre tipi di entrata: con albero entrata sporgente, con predisposizione attacco motore (campana e giunto) e predisposizione attacco motore COMPATTA, escluse grandezze 56, 63 e 75. I tre tipi di entrata possono essere montati indifferentemente nelle esecuzioni verticale e/o orizzontale.
- Il corpo riduttore in lega di alluminio, EN AL - AlSi9Cu - AL - AlSi7 UNI EN 1706 (56-63-75), in ghisa meccanica EN GJL 200 UNI EN 1561 (71-180) o in ghisa sferoidale EN GJS 400-15U UNI EN 1563 (200-225), abbondantemente nervato all'interno e all'esterno per garantire la rigidità, è lavorato su tutti i piani per consentire un facile posizionamento; inoltre un'unica camera di lubrificazione garantisce una maggiore dissipazione termica e una migliore lubrificazione di tutti gli organi interni.
- Gli ingranaggi sono costruiti in acciaio legato da cementazione e sottoposti a trattamento di cementazione e tempra. In particolare, la prima riduzione è costituita da due ingranaggi conici a dentatura spiroidale GLEASON con profilo accuratamente rodato, in acciaio 16NiCr4 o 18NiCrMo5 cementati e temprati. Gli ingranaggi cilindrici, a dentatura elicoidale, sono costruiti in acciaio 16NiCr4, 18NiCrMo5 o 20MnCr5 UNI EN 10084 cementati e temprati, rettificati entro la classe di qualità 6 della DIN 3962.
- L'utilizzo dei cuscinetti a rulli conici di qualità su tutti gli assi (ad eccezione del manicotto in entrata nella predisposizione attacco motore compatta, il quale è sostenuto da cuscinetti obliqui a sfere) consente al riduttore di ottenere delle durate molto elevate e di sopportare dei carichi radiali e assiali esterni molto elevati.
- L'albero lento cavo di serie in acciaio (disponibile a richiesta con calettatore), la possibilità di montare una flangia uscita su uno o entrambi i fianchi laterali e la predisposizione per il montaggio del dispositivo antiritorno esaltano la versatilità di questi riduttori facilitandone l'installazione.
- Il corpo riduttore, le flange, le campane ed i coperchi vengono verniciati esternamente di colore BLU RAL 5010, ad eccezione dei riduttori ortogonali delle grandezze 56, 63 e 75 realizzati in alluminio.

2.1 Characteristics

- *Built in 10 sizes with 2 reduction stages and in 9 sizes with 3 reduction stages.*
- *Three input types are available : projecting input shaft, pre-engineered motor coupling (bell and joint) and pre-engineered COMPACT motor coupling. (Size 56, 63 and 75 excluded). The 3 input types can be mounted either vertically and/or horizontally.*
- *Gear unit casing in aluminium alloy EN AL - AlSi9Cu - AL - AlSi7 UNI EN 1706 (56-63-75), in engineering cast iron, EN GJL 200 UNI EN 1561 (71-180) or spheroidal graphite cast iron EN GJS 400-15U UNI EN 1563 (200-225), is ribbed internally and externally to guarantee rigidity. It is machined on all surfaces for easy positioning. The single lubrication chamber guarantees improved heat dissipation and improved lubrication of all the internal components.*
- *The gears are built in casehardened compound steel and have undergone case-hardening and quench-hardening treatments. In particular, the first reduction stage consists of two GLEASON spiral bevel gears with precision ground profile, in 16CrNi4 or 18NiCrMo5 case-hardened and quench-hardened steel. The helical spur gears are built in 16NiCr4, 18NiCrMo5 or 20MnCr5 UNI EN 10084 quench-hardened and case-hardened steel, grinded in quality 6 DIN 3962.*
- *The use of high-quality tapered roller bearings on all shafts (except for the input sleeve on the pre-engineered compact motor coupling, which is supported by angular ball bearings) ensures long life and enables very high external radial and axial loads.*
- *The standard hollow output shaft made of steel (shrink disc available on request), the option of mounting an output flange on one or both sides and the possibility of mounting a backstop device make these gear units extremely versatile and easy to install.*
- *Gearbox housing, flanges, bells and covers are externally painted with BLUE RAL 5010, except for bevel helical gearboxes size 56, 63 and size 75 which are made in aluminium.*

2.1 Merkmale

- Erhältlich in 10 Größen zu je 2 Untersetzungsstufen und in 9 Größen zu je 3 Untersetzungsstufen.
- Vorgesehen sind drei Antriebsarten: mit vorstehender Antriebswelle, mit Auslegung für Motoranschluß (Glocke und Kupplung), mit Kompaktauslegung für Motoranschluß (Baugröße 56, 63 und 75 ausgenommen). Die drei Antriebstypen können alle sowohl in der vertikalen als auch in der horizontalen Ausführung verwendet werden.
- Die Getriebegehäuse ist aus Aluminiumlegierung EN AL - AlSi9Cu - AL - AlSi7 UNI EN 1706 (56-63-75), Maschinenguß EN GJL 200 UNI EN 1561 (71-180) oder aus Sphäroguß EN GJS 400-15U UNI EN 1563 (200-225) und mit Rippen versehen, die die Steifheit gewährleisten; die Bearbeitung aller Flächen ermöglicht eine leichte Positionierung; eine einzige Schmierkammer gewährleistet eine höhere Wärmedissipation und eine bessere Schmierung aller inneren Elemente.
- Die Zahnräder bestehen aus legiertem Einsatzstahl, sie wurden einsatz- und abschreckgehärtet. Insbesondere, die erste Untersetzungsstufe besteht aus zwei spiralverzahnten GLEASON – Kegelrädern mit sorgfältig eingelaufenem Profil aus einsatz- und abschreckgehärtetem 16CrNi4- oder 18NiCrMo5. Die Schrägstirnräder bestehen aus einsatz- und abschreckgehärtetem 16NiCr4, 18NiCrMo5- oder 20MnCr5-Stahl UNI EN 10084, geschliffen innerhalb Qualitätsklasse 6 der Spez. DIN 3962.
- An allen Achsen werden Qualitäts-Kegelrollenlager eingebaut. Diese gewährleisten eine hohe Lebensdauer und das Aushalten von sehr hohen Radial- und Axialbelastungen. (Ausnahme: Muffe am Antrieb bei Kompaktauslegung die von Schrägkugellagern gehalten wird)
- Die serienmäßige Abtriebshohlwelle aus Stahl (auf Wunsch mit Schrumpfscheibe erhältlich), die Möglichkeit der Montage eines Abtriebsflansches an einer oder an beiden Seiten und die Auslegung für die Montage der Rücklauf Sperre heben die Vielseitigkeit dieser Untersetzungsgetriebe hervor und erleichtern ihren Einbau.
- Getriebegehäuse, Flansche, Glocken und Deckel werden in BLAU RAL 5010 lackiert (mit Ausnahme von Kegelstirnradgetriebe Größe 56, 63 und 75 die aus Aluminium bestehen).

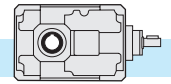

2.2 Designazione

2.2 Designation

2.2 Bezeichnung

Riduttore Gearbox Getriebe	Tipo entrata Input type Antriebsart	Grandezza Size Größe	Rotismo Gearing Räderwerk	Rapporto rid. Ratio Untersetzungsverhältnis	Predisposiz. Motor coupling Motoranschluss	Esecuzione Execution Ausführung	Posizione di montaggio Mounting position Baulage	Albero uscita cavo Hollow output shaft Abtriebshohlwelle	Flangia uscita Output flange Abtriebsflansch	Antiritorno Back-stop device Rücklauf Sperre	Calettatore Shrink disk Schrumpfscheibe	Entrata supplementare Additional input Zusatzantrieb
T	A	112	B	10	P.A.M.	O	B3	-	FLS	CW	C.S.	S.e.A.
Riduttore ad assi ortogonali Bevel/helical gearbox Kegelstirradgetriebe	A	56 63 71 75 90 112 140 180 200 225	B	$i_n =$ 5 ... 630	56 ... 225	O	B3 B6 B7 B8 VA VB	(1)	FLS	AW	C.S.	A
	C	56 63 75 80 100 125 160 180 200	C						FLD	CW	C.D.	C
	F					V			FL2			F

(1) Indicare il diametro dell'albero cavo solo se non è standard.
Es.: TA 112 B 10 90 O B3 40

(1) Diameter of the hollow output shaft to be specified only if it is not standard.
Ex.: TA 112 B 10 90 O B3 40

(1) Benennen Sie bitte den Durchmesser der Abtriebshohlwelle, insofern dieser nicht dem Standarddurchmesser entspricht
Beispiel: TA 112 B 10 90 O B3 40

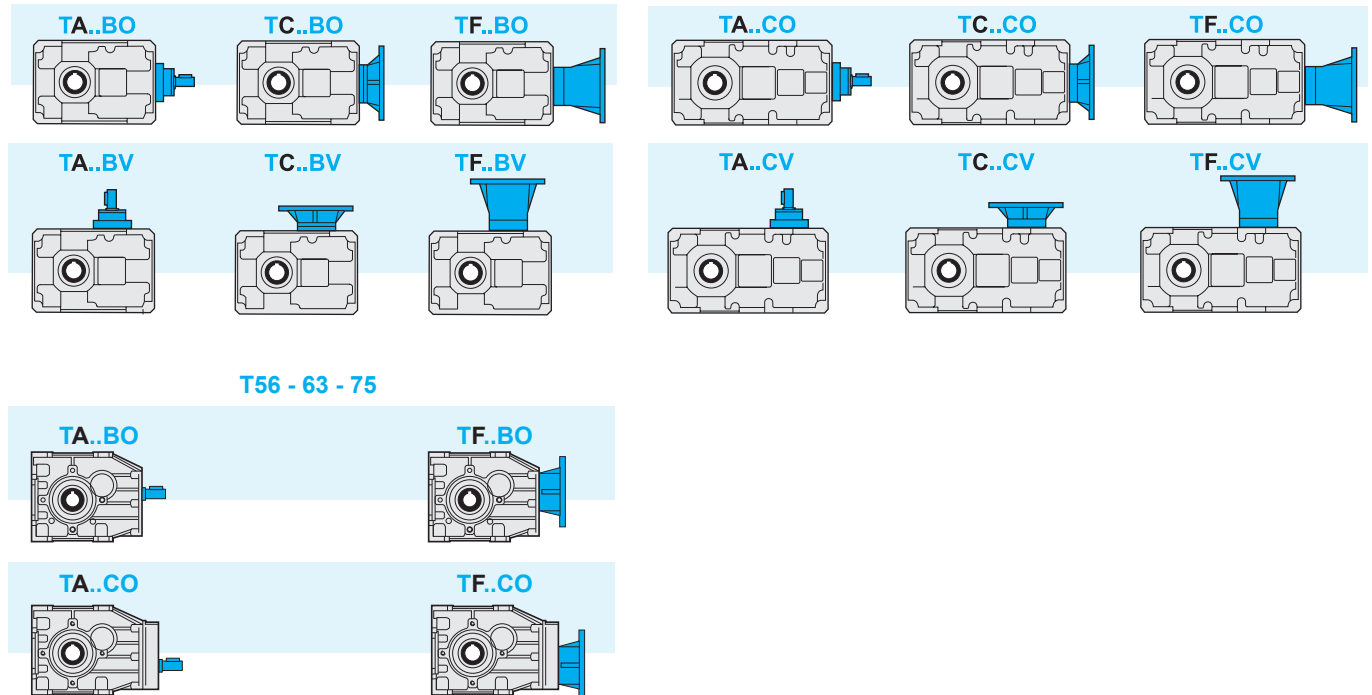

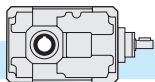

2.3 Sensi di rotazione alberi

Nei riduttori esecuzione orizzontale, per ottenere il senso di rotazione contrario al catalogo dell'albero lento mantenendo invariato il senso di rotazione dell'albero veloce, è sufficiente ruotare il riduttore di 180° attorno all'asse dell'albero veloce, utilizzando in pratica il piano di fissaggio opposto.

Nei riduttori esecuzione verticale è possibile fornire il senso di rotazione contrario al catalogo specificandolo al momento dell'ordine.

2.3 Direction of shaft rotation

With regard to horizontal mounted gearboxes, in order to get output rotation in a direction opposite to that given in the catalogue, nevertheless keeping input rotation direction unchanged, simply turn the gearbox 180° around the input shaft; in practice, mount the other way up.

Vertical units can be supplied with rotation direction opposite to that given in the catalogue; specify when ordering.

2.3 Drehrichtungen der Wellen

Wenn bei Untersetzungsgetrieben in waagerechter Ausführung für die Abtriebswelle eine andere als die im Katalog angegebene Drehrichtung gewünscht wird und die Antriebswelle ihre Drehrichtung beibehalten soll, so genügt es, das Getriebe um 180° um die Achse der Antriebswelle zu drehen, d.h. die gegenüberliegende Anschlußfläche zu verwenden.

Untersetzungsgetrieben in vertikaler Ausführung sind mit gegensätzlicher Drehrichtung lieferbar, deswegen ist es bei der Bestellung anzugeben, falls die umgekehrte Drehrichtung gewünscht wird.

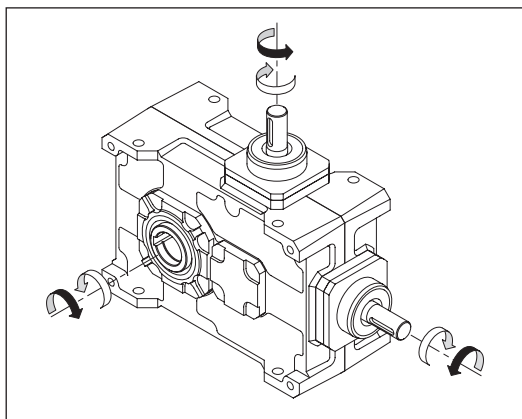

Sensi di rotazione standard
Standard direction of rotation
Standarddrehrichtungen.

2.4 Entrata supplementare

L'albero entrata può essere montato nella posizione orizzontale (O) o verticale (V), eccetto le grandezze 56,63 e 75. Il cambio di versione può essere facilmente realizzato anche successivamente al primo montaggio.

Eccetto le grandezze 56, 63 e 75, esiste la possibilità di montare una seconda entrata scegliendola, in base alle necessità, tra quelle previste: TA, TC, TF.

In questo caso occorre definire la versione del riduttore con l'entrata principale e specificare quindi la seconda entrata.

2.4 Additional input

The input shaft can be mounted either horizontally (O) or vertically (V) on all sizes except for 56, 63 and 75. The version can be easily changed even after the first assembly.

Except for sizes 56, 63 and 75, there is the possibility of mounting a second input; the available options are TA, TC, TF.

Both the main input and the additional second input shall be specified when ordering.

2.4 Zusatzantrieb

Die Antriebswelle kann entweder waagrecht (O) oder senkrecht (V) montiert werden ((Baugröße 56, 63 und 75 ausgenommen). Auch nach der ersten Montage kann die Version leicht geändert werden. Mit Ausnahme von den Größen 56,63 und 75 kann ein zweiter Antrieb TA, TC oder TF montiert werden.

Bei der Bestellung sollte sowohl der hauptsächliche Antrieb als auch der zweite Antrieb angegeben werden.

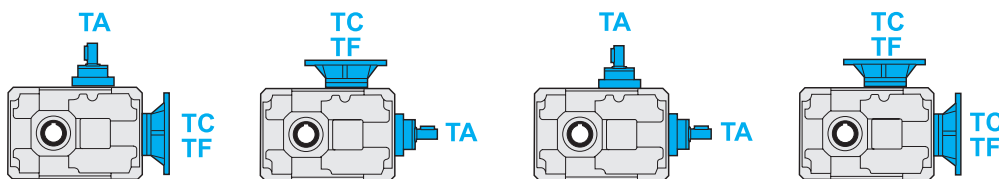

2.5 Rendimento

Il valore del rendimento dei riduttori può essere stimato con sufficiente approssimazione in base al numero di riduzioni, trascurando le variazioni non significative attribuibili alle varie grandezze e rapporti.

2.5 Efficiency

The efficiency value of the gear units can be estimated sufficiently well on the basis of the number of reduction stages, ignoring non-significant variations which can be attributed to the various sizes and ratios.

2.5 Wirkungsgrad

Der Wirkungsgrad des Getriebes kann mit ausreichender Annäherung aufgrund der Anzahl der Untersetzungsstufen ermittelt werden. Dabei können die unwesentlichen Veränderungen, die auf die verschiedenen Größen und Untersetzungsverhältnisse zurückzuführen sind, ausser Acht gelassen werden.

η	T...B	T...C
	0.95	0.93

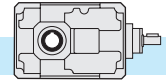

2.6 Velocità in entrata

Tutte le prestazioni dei riduttori sono calcolate in base ad una velocità in entrata di 1400 min⁻¹.

Tutti i riduttori ammettono velocità fino a 3000 min⁻¹ anche se è consigliabile, dove l'applicazione lo permette, utilizzare valori inferiori a 1400 min⁻¹.

Nella tabella sottostante riportiamo i coefficienti correttivi della potenza in entrata P alle varie velocità riferita ad Fs = 1

2.6 Input speed

All calculations of gear unit performance are based on an input speed of 1400 min⁻¹. All gear units permit speed up to 3000 min⁻¹, nevertheless it is advisable to keep below 1400 min⁻¹, depending on application.

The table below reports input power P corrective coefficients at the various speeds, with Fs = 1.

2.6 Antriebsdrehzahl

Bei der Berechnung der Getriebeleistungen wurde eine Antriebsdrehzahl von 1400 min⁻¹ berücksichtigt.

Bei allen Getrieben sind Antriebsdrehzahlen bis 3000 min⁻¹ möglich; es ist jedoch ratsam, die Drehzahlen unter 1400 min⁻¹ zu halten, wenn die Anwendung es ermöglicht.

In der folgenden Tabelle finden Sie die Korrekturkoeffizienten für die Antriebsleistung P bei den verschiedenen Drehzahlen, bezogen auf Fs = 1.

Tab. 1

n ₁ (rpm)	3000	2800	2200	1800	1400	900	700	500
Pc (kW)	P x 1.9	P x 1.8	P x 1.48	P x 1.24	P x 1	P x 0.7	P x 0.56	P x 0.42

2.7 Potenza termica

I valori delle potenze termiche, P₁₀ (kW), sono riportati nella tabella seguente, in funzione di grandezza, rapporto e velocità entrata del riduttore.

I valori sono calcolati considerando l'utilizzo di olio sintetico ISO 320.

Vedere paragrafo 1.4 per la scelta dei fattori correttivi.

2.7 Thermal power

The following table shows the values of thermal power P₁₀ (kW) for each gearbox size on the basis of ratio and input speed.

The values have been calculated considering the utilization of synthetic oil ISO 320. See chapter 1.4 for the corrective coefficients.

2.7 Thermische Leistung

Die folgende Tabelle enthält die Werte P₁₀ der thermischen Leistung (kW) je nach Getriebegröße und abhängig von Untersetzung und von Drehzahlen am Getriebeantrieb. Die angegebenen Werte beziehen sich auf Schmierung mit synthetischen Öl ISO 320.

Im Abschnitt 1.4 finden Sie die Korrekturkoeffizienten.

Potenza Termica / Thermal power / Thermische Leistung																				
P ₁₀ [kW]																				
i _n	T56B		T63B		T75B		T63B		T90B		T112B		T140B		T180B		T200B		T225B	
	1400	2800	1400	2800	1400	2800	1400	2800	1400	2800	1400	2800	1400	2800	1400	2800	1400	2800	1400	2800
8							-	-	-	-	-	-	-	-	-	48.3	45.4	59	48	
10	4	3.4	5.5	4.7	5.6	4.8	4	6.3	10.8	17	32	43.3	42	55	45.8					
12.5							3.7	5.8	10	15.5	28.7	39	38.5	49	41.5					
16							3.3	5.2	9	14	25.8	33.8	37							
18	-	-	-	-	-	-	-	-	-	-	12.9	24.6	-	-						
20							2.8	4.4	7.7	11.8	23.5	30.8	35							
25	4	3.4	5.5	4.7	5.6	4.8	2.7	4.2	7.3	11	21.6	28.6	32.3							
31.5							2.5	3.9	6.8	10.4	20	25.6	27.7							
35	-	-	-	-	-	-	-	-	-	-	10	19	-	-						
40	4	3.4	5.5	4.7	5.6	4.8	2.3	3.6	6.3	9.5	18	23.9	25.8							
50			5.5	4.7			1.9	3	4.7	7.6	11.3	17.4	-							
63							1.8	2.8	4.4	7.3	10.7	16.6	-							
70	-	-	-	-	-	-	-	-	-	-	7	10.3	-	-						
80							1.7	2.6	4.2	6.8	10	-	-							

Potenza Termica / Thermal power / Thermische Leistung																		
P ₁₀ [kW]																		
i _n	T56C		T63C		T75C		T80C		T100C		T125C		T160C		T180C		T200C	
	1400	2800	1400	2800	1400	2800	1400	2800	1400	2800	1400	2800	1400	2800	1400	2800	1400	2800
40					-	-	-	-	-	-	-	-	-	-	-	-	32	34.2
50							3.6	5.8	9.7	16.8	18.2	21	23.3	30.7	32.6			
63							3.4	5.3	9	15.5	17	19.5	21.6	28.5	30			
80							3.2	5	8.6	14.6	16	18.4	20.4	26.4	27.7			
100	3.3	2.8	4.2	3.6	4.3	3.7	2.9	4.5	7.7	13	14	17	18.4	24.8	27			
125							2.7	4.2	7.3	12.3	13.2	15.6	17	23.3	25.3			
160							2.6	4	7	11.7	12.5	14.7	16	21.8	23.5			
200							2.5	4	6.6	11	12	13.6	14.7	16	17.5			
225	-	-	-	-	-	-	-	-	-	6	10.2	11	-	-	-	-		
250	3.3	2.8	4.2	3.6	4.3	3.7	2.2	3.3	5.3	9.3	10	12	12.8	15.3	16.7			
315							2	3.2	5.2	9	9.7	11.4	12.3	14.6	15.8			
400							2	3	5	8.6	9.3	10.7	11.5	-	-			
450							-	-	4.9	8.3	9	-	-	-	-			
500	-	-	-	-	-	-	2	3	4.7	8	8.6	-	-	-	-			
550							-	-	4.7	7.9	8.5	-	-	-	-			
630							2	3	4.6	7.8	8.4	-	-	-	-			

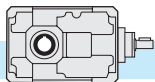

2.8 Dati tecnici

2.8 Technical data

2.8 Technische Daten

T	n ₁ = 1400			TC - TF				TA	
	in	ir	n ₂ rpm	T ₂ Nm	P1 kW	FS'	IEC	T _{2M} Nm	P kW
56B	8	8.06	174	94	1.8	1.2	56	110	2.1
	10	10.17	138	120	1.8	1.0	63	120	1.8
	12.5	12.31	114	120	1.5	1.1	(B5)	130	1.6
	16	15.00	93	107	1.1	1.3	71	140	1.4
	20	20.33	69	140	1.1	1.0	80	140	1.1
	25	24.62	57	140	0.9	1.0	90	140	0.90
	31.5	30.00	47	107	0.55	1.3	(B5) (B14)	140	0.70
	40	39.38	36	140	0.55	1.0	TF	140	0.55
	50	48.00	29	115	0.37	1.2	TF	140	0.45
56C	40	40.28	35	140	0.55	1.0	56	140	0.55
	50	50.83	28	119	0.37	1.2	63	140	0.45
	63	61.54	23	140	0.37	1.0	(B5)	140	0.37
	80	75.00	19	119	0.25	1.2	71	145	0.30
	100	101.67	14	145	0.22	1.0	80	145	0.22
	125	123.08	11	141	0.18	1.0	90	145	0.19
	160	150.00	9	124	0.13	1.2	(B5) (B14)	145	0.15
	200	196.92	7	136	0.11	1.1	TF	145	0.12
	250	240.00	6	135	0.09	1.0	TF	135	0.09
63B	8	7.94	176	93	1.8	1.7	56	155	3.0
	10	10.18	138	119	1.8	1.4	63	170	2.6
	12.5	12.50	112	146	1.8	1.3	(B5)	185	2.3
	16	15.88	88	185	1.8	1.0	71	185	1.8
	20	20.36	69	200	1.5	1.0	80	200	1.5
	25	25.00	56	180	1.1	1.1	90	200	1.2
	31.5	31.00	45	181	0.9	1.1	(B5) (B14)	200	1.0
	40	40.00	35	194	0.75	1.0	TF	200	0.80
	50	49.60	28	177	0.55	1.0	TF	200	0.60
63	60.80	23	146	0.37	1.0	TF	170	0.40	
63C	40	39.71	35	194	0.75	1.0	56	200	0.80
	50	50.89	28	178	0.55	1.2	63	210	0.65
	63	62.50	22	210	0.55	1.0	(B5)	210	0.55
	80	79.41	18	186	0.37	1.1	71	210	0.42
	100	101.79	14	161	0.25	1.3	80	210	0.33
	125	125.00	11	198	0.25	1.0	90	210	0.26
	160	155.00	9	210	0.22	1.0	(B5) (B14)	210	0.22
	200	200.00	7	165	0.13	1.3	TF	210	0.17
	250	248.00	6	200	0.13	1.0	TF	200	0.13
315	304.00	5	180	0.09	1.0	TF	180	0.09	
75B	8	7.87	178	204	4.0	1.2	71	245	4.8
	10	9.82	143	254	4.0	1.1	80	279	4.4
	12.5	12.67	110	330	4.0	1.0	90	330	4.0
	16	15.43	91	299	3.0	1.1	100	329	3.3
	20	19.38	72	277	2.2	1.3	112	360	2.9
	25	25.00	56	356	2.2	1.0	(B5) (B14)	356	2.2
	31.5	30.45	46	355	1.8	1.1	TF	391	2.0
	40	40.00	35	285	1.1	1.3	TF	371	1.4
	50	48.73	29	344	1.1	1.1	TF	378	1.2

T	n ₁ = 1400			TC - TF				TA	
	in	ir	n ₂ rpm	T ₂ Nm	P1 kW	FS'	IEC	T _{2M} Nm	P kW
75C	50	49.08	29	330	1.1	1.0	63	330	1.1
	63	63.33	22	303	0.75	1.1	(B5)	333	0.8
	80	77.15	18	271	0.55	1.3	71	352	0.70
	100	96.88	14	350	0.55	1.0	80	350	0.55
	125	125.00	11	299	0.37	1.2	90	359	0.44
	160	152.27	9	247	0.25	1.4	(B5) (B14)	346	0.35
	200	200.00	7	317	0.25	1.2	TF	380	0.30
	250	243.64	6	370	0.25	1.0	TF	370	0.25
	71B	10	10.25	137	120	1.8	1.9	63	230
12.5		13.05	107	152	1.8	1.6	71	240	2.8
16		15.63	90	182	1.8	1.4	80	250	2.5
20		19.64	71	229	1.8	1.3	90	290	2.3
25		24.99	56	243	1.5	1.2	(B5)	280	1.7
31.5		29.95	47	213	1.1	1.2	TC-TF	260	1.3
40		38.73	36	226	0.9	1.1	80	240	1.0
50		50.18	28	244	0.75	1.1	(B14)	260	0.80
63		60.13	23	214	0.55	1.2	TC	260	0.70
80	77.76	18	186	0.37	1.3	TC	240	0.50	
90B	5*	4.56	307	118	4	1.8	71	210	7.2
	6.3*	6.26	224	162	4	1.8	80	290	7.2
	10	10.25	137	266	4	1.8	90	480	7.2
	12.5	13.05	107	338	4	1.6	100	530	6.3
	16	15.63	90	405	4	1.4	112	550	5.4
	20	19.64	71	509	4	1.2	(B5)	620	4.9
	25	24.99	56	630	4	1.0	TC-TF	630	4.0
	31.5	29.95	47	560	3	1.0	90*	560	3.0
	40	38.73	36	452	1.8	1.1	(B14)	500	2.0
50	50.18	28	488	1.5	1.1	TC	550	1.7	
63	60.13	23	570	1.5	1.0	TC	570	1.5	
80	77.76	18	454	0.9	1.1	TC	505	1.0	
80C	50	52.18	27	596	1.8	1.1	63	660	2.0
	63	62.53	22	595	1.5	1.1	71	680	1.7
	80	79.58	18	555	1.1	1.3	80	710	1.4
	100	99.97	14	698	1.1	1.1	90	740	1.2
	125	119.78	12	684	0.9	1.1	(B5)	740	1.0
	160	152.45	9	532	0.55	1.3	TC-TF	680	0.70
	200	182.67	8	637	0.55	1.1	80	700	0.60
	250	240.51	6	565	0.37	1.3	(B14)	750	0.49
	315	306.11	5	719	0.37	1.0	TC	740	0.38
400	366.78	4	582	0.25	1.2	TC	700	0.30	
500	474.35	3	660	0.22	1.0	TC	660	0.22	
630	613.46	2	506	0.13	1.2	TC	620	0.16	
112B	5*	4.86	288	290	9.2	1.5	80	430	13.9
	10	10.25	137	611	9.2	1.5	90	920	13.9
	12.5	13.05	107	778	9.2	1.3	100	1000	11.8
	16	15.63	90	932	9.2	1.2	112	1100	10.9
	20	19.64	71	1171	9.2	1.0	132	1190	9.4
	25	24.99	56	1215	7.5	1.1	(B5)	1280	7.9
	31.5	29.95	47	1067	5.5	1.1	TC-TF	1220	6.3
	40	38.73	36	1004	4	1.0	TC-TF	1050	4.2
	50	50.18	28	976	3	1.1	TC-TF	1070	3.3
63	60.13	23	857	2.2	1.3	TC-TF	1140	2.9	
80	77.76	18	907	1.8	1.2	TC-TF	1080	2.1	

- Flange quadrate / Square flanges / Viereckige Flansche
- * Rapporti speciali / Special ratios / Sonderverhältnisse
- Verifica termica necessaria / Thermal rating needed / Thermische - Prüfung erforderlich

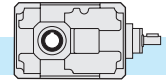

2.8 Dati tecnici

2.8 Technical data

2.8 Technische Daten

T	n ₁ = 1400			TC - TF				TA		
	in	ir	n ₂ rpm	T ₂ Nm	P1 kW	FS'	IEC	T _{2M} Nm	P kW	
100C	50	52.18	27	993	3	1.3		1300	3.9	
	63	62.53	22	1190	3	1.1	71	1350	3.4	
	80	79.58	18	1111	2.2	1.3	80	1410	2.8	
	100	99.97	14	1395	2.2	1.1	90	1470	2.3	
	125	119.78	12	1368	1.8	1.1	100	1480	1.9	
	160	152.45	9	1064	1.1	1.3	112	1360	1.4	
	200	182.67	8	1275	1.1	1.1	(B5)	1400	1.2	
	250	240.51	6	1330	0.90	1.1		1500	1.0	
	315	306.11	5	1456	0.75	1.1	90•	1480	0.80	
	400	366.78	4	1280	0.55	1.1	(B14)	1400	0.60	
	500	474.35	3	1113	0.37	1.3	TC	1360	0.50	
630	613.46	2	973	0.25	1.2		1240	0.30		
140B	7*	6.88	203	983	22	1.3		1200	27.9	
	10	10.25	137	1461	22	1.3		1850	27.9	
	12.5	13.05	107	1860	22	1.1		2050	24.3	
	16	15.63	90	1874	18.5	1.2	80	2200	21.7	
	18	17.43	80	2098	18.5	1.1	90	2300	20.3	
	20	19.64	71	2354	18.5	1.0	100	2400	18.9	
	25	24.99	56	2429	15	1.0	112	2540	15.7	
	31.5	29.95	47	2135	11	1.1	132	2300	11.9	
	35	33.38	42	1620	7.5	1.4	160	2300	10.6	
	40	38.73	36	1882	7.5	1.2	180	2210	8.8	
	50	50.18	28	1789	5.5	1.2	(B5)	TC-TF	2120	6.5
63	60.13	23	2143	5.5	1.1			2350	6.0	
70	67.03	21	2376	5.5	1.0			2400	5.5	
80	77.76	18	2016	4	1.1			2250	4.5	
125C	50	52.18	27	2483	7.5	1.1		2650	8.0	
	63	62.53	22	2182	5.5	1.3		2760	7.0	
	80	79.58	18	2777	5.5	1.0		2880	5.7	
	100	99.97	14	2537	4	1.2		3000	4.7	
	125	119.78	12	3000	4	1.0	80	3000	4.0	
	160	152.45	9	2128	2.2	1.3	90	2720	2.8	
	200	182.67	8	2549	2.2	1.1	100	2800	2.4	
	225	203.63	7	2284	1.8	1.1	112	2580	2.0	
	250	240.51	6	2746	1.8	1.1	132	3050	2.0	
	315	306.11	5	2913	1.5	1.0	(B5)	2960	1.5	
	400	366.78	4	2560	1.1	1.1	TC-TF	2800	1.2	
450	408.87	3	2350	0.90	1.1		2600	1.0		
500	474.35	3	2640	0.90	1.0		2640	0.90		
550	528.78	3	2562	0.75	1.1		2800	0.85		
630	613.46	2	2140	0.55	1.2		2550	0.70		
180B	10	10.25	137	1993	30	2.0		3900	58.7	
	12.5	13.05	107	2536	30	1.7		4300	50.9	
	16	15.63	90	3039	30	1.5		4500	44.4	
	18	17.43	80	3402	30	1.4	100	4800	42.5	
	20	19.64	71	3818	30	1.3	112	5100	40.1	
	25	24.99	56	4859	30	1.1	132	5230	32.3	
	31.5	29.95	47	4269	22	1.1	160	4680	24.1	
	35	33.38	42	3996	18.5	1.2	180	4650	21.5	
	40	38.73	36	3764	15	1.1	200	4300	17.1	
	50	50.18	28	3577	11	1.2	(B5)	TC-TF	4300	13.2
	63	60.13	23	4286	11	1.1		4780	12.3	
70	67.03	21	3975	9.2	1.2		4650	10.7		
80	77.76	18	3779	7.5	1.2		4380	8.7		

• Flange quadrate / Square flanges / Viereckige Flansche

* Rapporti speciali / Special ratios / Sonderverhältnisse

Verifica termica necessaria / Thermal rating needed

Thermische - Prüfung erforderlich

T	n ₁ = 1400			TC - TF				TA		
	in	ir	n ₂ rpm	T ₂ Nm	P1 kW	FS'	IEC	T _{2M} Nm	P kW	
160C	50	52.18	27	4966	15	1.0		5130	15.5	
	63	62.53	22	4363	11	1.2		5350	13.5	
	80	79.58	18	5570	11	1.0		5570	11.0	
	100	99.97	14	5800	9.2	1.0	80	5800	9.2	
	125	119.78	12	5699	7.5	1.0	90	5800	7.6	
	160	152.45	9	5319	5.5	1.0	100	5470	5.7	
	200	182.67	8	4635	4	1.2	112	5560	4.8	
	225	203.63	7	5149	4	1.1	160	5800	4.5	
	250	240.51	6	5890	4	1.0	180	5890	4.0	
	315	306.11	5	5920	3	1.0	(B5)	5826	3.0	
	400	366.78	4	5119	2.2	1.1	TC-TF	5600	2.4	
450	408.87	3	5747	2.2	1.0		5700	2.2		
500	474.35	3	5280	1.8	1.0		5280	1.8		
550	528.78	3	5124	1.5	1.1		5360	1.6		
630	613.46	2	4281	1.1	1.2		4960	1.3		
200B	8	8.14	172	2370	45	2.1		5000	94.8	
	10	10.43	134	3050	45	1.8	112	5500	81.4	
	12.5	12.60	111	3680	45	1.6	132	6000	73.5	
	16	15.63	90	4540	45	1.4	160	6500	64.2	
	20	17.65	79	5170	45	1.3	180	7100	62.1	
	25	24.14	58	7030	45	1.0	200	7150	45.7	
	31.5	29.95	47	7150	37	1.0	(B5)	TC-TF	7250	37.4
	40	33.82	41	6575	30	1.1	225	7300	33.3	
	50	47.93	29	6833	22	1.1	(B5)	TF	7400	23.8
	63	54.13	26	6489	18.5	1.1		7400	21.1	
	180C	50	53.11	26	6234	18.5	1.1		7240	21.0
63		63.64	22	7280	18.5	1.0	80	7280	18.5	
80		76.85	18	7313	15	1.0	90	7420	15.2	
100		99.99	14	6936	11	1.1	100	7500	11.9	
125		122.88	11	7172	9.2	1.0	112	7500	9.6	
160		147.23	10	7005	7.5	1.1	132	7550	8.1	
200		190.41	7	6644	5.5	1.1	160	7600	6.3	
250		246.73	6	6261	4	1.2	180	7650	4.9	
315		295.63	5	7502	4	1.0	(B5)	TC-TF	7700	4.1
400		382.33	4	7276	3	1.1		7950	3.3	
225B		8	8.44	166	2461	45	3.0		7500	137.1
	10	10.13	138	2955	45	2.8	132	8300	126.4	
	12.5	12.45	112	3630	45	2.5	160	9100	112.8	
	16	15.93	88	4644	45	2.2	180	10000	96.9	
	20	19.13	73	5577	45	1.9	200	10700	86.3	
	25	23.49	60	6850	45	1.6	225	11000	72.3	
	31.5	30.29	46	8832	45	1.3	(B5)	TF	11100	56.6
40	37.09	38	10800	45	1.0		10800	45.0		
200C	40	42.62	33	8110	30	1.3		10900	40.3	
	50	51.18	27	9740	30	1.1	100	11000	33.9	
	63	62.86	22	8772	22	1.3	112	11350	28.5	
	80	76.97	18	10742	22	1.0	132	11050	22.6	
	100	98.04	14	11200	18.5	1.0	160	11200	18.5	
	125	120.41	12	11459	15	1.0	180	11500	15.1	
	160	147.45	9	10290	11	1.1	200	11200	12.0	
	200	196.87	7	11400	9.2	1.0	(B5)	TC-TF	11400	9.2
	250	241.79	6	11504	7.5	1.0		11700	7.6	
	315	296.07	5	10330	5.5	1.1		11850	6.3	

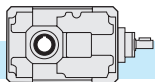

2.9 **Momenti d'inerzia** [Kg·cm²]
(riferiti all'albero veloce in entrata)

2.9 **Moments of inertia** [Kg·cm²]
(referred to input shaft)

2.9 **Trägheitsmoment** [Kg·cm²]
(bez. Antriebswelle)

TA..B - TC..B - TF..B

56B	i _n	TA	TF				
			IEC B5				
			56	63	71	80	90
8	0.25			0.32	0.40	0.60	0.77
10	0.22		0.29	0.29	0.37	0.56	0.74
12.5	0.20		0.27	0.27	0.35	0.54	0.72
16	0.18		0.25	0.26	0.33	0.53	0.71
20	0.08		0.15	0.15	0.22	0.42	0.60
25	0.07		0.14	0.15	0.22	0.42	0.59
31.5	0.07		0.14	0.14	0.21	0.41	0.59
40	0.04		0.11	0.12	0.19	0.39	0.56
50	0.04		0.11	0.11	0.19	0.39	0.56

63B	i _n	TA	TF				
			IEC B5				
			56	63	71	80	90
8	0.40		0.47	0.47	0.55	0.74	0.92
10	0.34		0.41	0.42	0.49	0.69	0.87
12.5	0.31		0.38	0.38	0.45	0.65	0.83
16	0.16		0.23	0.24	0.31	0.51	0.68
20	0.15		0.22	0.22	0.29	0.49	0.67
25	0.14		0.21	0.21	0.29	0.48	0.66
31.5	0.13		0.20	0.21	0.28	0.48	0.65
40	0.07		0.15	0.15	0.22	0.42	0.60
50	0.07		0.14	0.15	0.22	0.42	0.60
63	0.07		0.14	0.15	0.22	0.42	0.59

75B	i _n	TA	TF			
			IEC B5			
			71	80	90	100-112
8	1.35		1.70	2.10	2.01	3.05
10	1.21		1.55	1.96	1.87	2.91
12.5	1.05		1.39	1.80	1.71	2.75
16	0.99		1.34	1.74	1.65	2.69
20	0.36		0.71	1.11	1.02	2.06
25	0.32		0.67	1.07	0.98	2.02
31.5	0.30		0.65	1.06	0.97	2.01
40	0.16		0.51	0.92	0.82	1.86
50	0.15		0.50	0.91	0.82	1.86

71B	i _n	TA	TC				TF			
			IEC B5				IEC B5			
			63	71	80	90	63	71	80	90
10	0.95		1.00	1.14	1.52	1.57	1.20	1.22	1.89	2.96
12.5	0.89		0.94	1.08	1.46	1.51	1.14	1.16	1.83	2.90
16	0.85		0.91	1.05	1.43	1.47	1.11	1.12	1.80	2.87
20	0.38		0.43	0.57	0.94	0.99	0.63	0.65	1.32	2.39
25	0.36		0.41	0.55	0.93	0.98	0.61	0.63	1.31	2.37
31.5	0.35		0.40	0.54	0.92	0.97	0.61	0.62	1.30	2.36
40	0.34		0.39	0.53	0.91	0.96	0.60	0.61	1.29	2.35
50	0.19		0.22	0.36	0.74	0.79	0.44	0.46	1.14	2.20
63	0.19		0.22	0.36	0.74	0.79	0.44	0.46	1.14	2.20
80	0.19		0.22	0.36	0.74	0.79	0.44	0.46	1.13	2.20

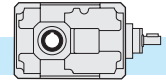







2.9 **Momenti d'inerzia** [Kg·cm²]
(riferiti all'albero veloce in entrata)



2.9 **Moments of inertia** [Kg·cm²]
(referred to input shaft)

2.9 **Trägheitsmoment** [Kg·cm²]
(bez. Antriebswelle)

TA..B - TC..B - TF..B

90B	i _n	TA 	TC 				TF 			
			IEC B5				IEC B5			
			71	80	90	110-112	71	80	90	110-112
5*	4.36	4.77	4.94	5.31	6.15	5.22	5.35	6.53	8.70	
6.3*	3.67	4.07	4.24	4.62	5.46	4.52	4.66	5.84	8.00	
10	2.77	3.18	3.35	3.73	4.57	3.63	3.77	4.94	7.11	
12.5	2.60	3.01	3.18	3.56	4.40	3.46	3.60	4.77	6.94	
16	2.49	2.90	3.07	3.44	4.28	3.35	3.48	4.66	6.82	
20	1.16	1.53	1.70	2.08	2.92	2.02	2.16	3.33	5.50	
25	1.12	1.49	1.66	2.04	2.88	1.98	2.11	3.29	5.45	
31.5	1.09	1.46	1.63	2.00	2.84	1.94	2.08	3.25	5.42	
40	1.06	1.43	1.60	1.98	2.82	1.92	2.05	3.23	5.40	
50	0.65	0.98	1.15	1.53	2.37	1.50	1.64	2.81	4.98	
63	0.64	0.97	1.14	1.52	2.36	1.50	1.63	2.81	4.97	
80	0.63	0.97	1.14	1.51	2.35	1.49	1.62	2.80	4.97	

112B	i _n	TA 	TC 				TF 			
			IEC B5				IEC B5			
			80	90	110-112	132	80	90	110-112	132
5*	12.20	13.70	13.57	14.53	17.67	14.53	14.46	16.78	30.77	
10	8.51	9.44	9.31	10.26	13.40	10.84	10.77	13.09	27.08	
12.5	7.67	8.60	8.47	9.42	12.56	10.00	9.93	12.25	26.24	
16	7.27	8.20	8.07	9.03	12.16	9.61	9.54	11.85	25.85	
20	3.62	4.46	4.33	5.29	8.43	5.96	5.89	8.20	22.20	
25	3.39	4.23	4.10	5.06	8.20	5.73	5.66	7.97	21.97	
31.5	3.29	4.13	4.00	4.95	8.09	5.62	5.55	7.87	21.86	
40	3.21	4.05	3.92	4.87	8.01	5.55	5.47	7.79	21.79	
50	1.79	2.50	2.37	3.32	6.46	4.13	4.05	6.37	20.37	
63	1.77	2.47	2.35	3.30	6.44	4.10	4.03	6.34	20.34	
80	1.75	2.46	2.33	3.28	6.42	4.08	4.01	6.33	20.32	

140B	i _n	TA 	TC 						TF 					
			IEC B5						IEC B5					
			80	90	110-112	132	160	180	80	90	110-112	132	160	180
7*	29.65	30.78	30.65	30.79	33.99	38.41	41.43	31.85	34.23	34.40	49.26	51.44	96.71	
10	25.04	26.17	26.04	26.18	29.38	33.80	36.82	27.23	29.62	29.79	44.65	46.83	92.10	
12.5	22.28	23.41	23.28	23.42	26.62	31.05	34.06	24.48	26.86	27.04	41.90	44.08	89.34	
16	21.26	22.39	22.26	22.40	25.60	30.02	33.04	23.46	25.84	26.01	40.87	43.05	88.32	
18	20.60	21.73	21.60	21.74	24.94	29.36	32.38	22.79	25.18	25.36	40.22	42.40	87.66	
20	9.17	10.13	10.00	10.14	13.34	17.76	20.78	11.37	13.75	13.92	28.78	30.97	76.23	
25	8.42	9.38	9.25	9.39	12.59	17.01	20.03	10.62	13.00	13.17	28.03	30.22	75.48	
31.5	8.14	9.10	8.97	9.11	12.31	16.73	19.75	10.34	12.72	12.90	27.76	29.94	75.20	
35	7.96	8.92	8.79	8.93	12.13	16.55	19.57	10.16	12.54	12.72	24.58	29.76	75.02	
40	7.92	8.87	8.74	8.88	12.08	16.51	19.52	10.11	12.49	12.67	27.53	29.71	74.98	
50	4.28	4.94	4.81	4.95	8.15	12.57	15.59	6.47	8.85	9.03	23.89	26.07	71.34	
63	4.21	4.87	4.74	4.88	8.08	12.50	15.52	6.40	8.79	8.96	23.82	26.00	71.27	
70	4.17	4.82	4.69	4.83	8.03	12.45	15.47	6.36	8.74	8.92	23.78	25.96	71.22	
80	4.15	4.81	4.68	4.82	8.02	12.44	15.46	6.35	8.73	8.91	23.77	25.95	71.21	

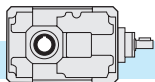







2.9 **Momenti d'inerzia** [Kg·cm²]
(riferiti all'albero veloce in entrata)



2.9 **Moments of inertia** [Kg·cm²]
(referred to input shaft)

2.9 **Trägheitsmoment** [Kg·cm²]
(bez. Antriebswelle)

TA..B - TC..B - TF..B

	i _n	TA 	 TC					 TF				
			IEC B5					IEC B5				
			100-112	132	160	180	200	100-112	132	160	180	200
180B	10	78.24	80.83	86.51	85.51	88.42	98.81	97.86	99.23	101.41	150.52	147.05
	12.5	68.84	71.43	77.11	76.11	79.02	89.41	88.46	89.82	92.01	141.12	137.65
	16	66.22	68.81	74.49	73.49	76.40	86.79	85.84	87.20	89.38	138.50	135.03
	18	64.77	67.36	73.04	72.04	74.95	85.34	84.39	85.75	87.94	137.05	133.58
	20	28.52	31.29	36.97	35.97	38.88	49.27	48.14	49.50	51.68	100.80	97.33
	25	25.96	26.14	31.82	30.82	33.73	44.12	45.58	46.94	49.12	98.24	94.77
	31.5	25.25	28.01	33.69	32.69	35.60	45.99	44.86	46.23	48.41	97.53	94.05
	35	24.85	27.62	33.3	32.30	35.21	45.60	44.47	45.83	48.01	97.13	93.66
	40	24.43	27.19	32.88	31.88	34.79	45.17	44.04	45.41	47.59	96.71	93.23
	50	11.97	14.25	19.93	18.93	21.84	32.23	31.59	32.95	35.13	84.25	80.78
	63	11.80	14.07	19.75	18.75	21.66	32.05	31.41	32.78	34.96	84.08	80.60
70	11.70	13.97	19.66	18.66	21.57	31.95	31.31	32.68	34.86	83.98	80.50	
80	11.59	13.87	19.55	18.55	21.46	31.85	31.21	32.57	34.75	83.87	80.40	

	i _n	TA 	 TC					 TF					
			IEC B5					IEC B5					
			110-112	132	160	180	200	110-112	132	160	180	200	225
200B	8	109.38	110.72	116.40	115.40	118.31	128.70	129.00	130.37	132.55	181.66	178.19	181.78
	10	95.71	97.05	102.73	101.73	104.64	115.03	115.33	116.69	118.87	167.99	164.52	168.11
	12.5	85.34	86.68	92.36	91.36	94.27	104.66	104.96	106.32	108.51	157.62	154.15	157.74
	16	79.58	80.92	86.60	85.60	88.51	98.90	99.20	100.56	102.74	151.86	148.39	151.98
	20	75.15	76.49	82.17	81.17	84.08	94.47	94.77	96.13	98.32	147.43	143.96	147.55
	25	31.37	32.88	38.56	37.56	40.47	50.86	50.98	52.35	54.53	103.65	100.17	103.76
	31.5	29.80	31.31	36.99	35.99	38.90	49.29	49.41	50.78	52.96	102.08	98.60	102.20
	40	28.59	30.11	35.79	34.79	37.70	48.09	48.21	49.57	51.75	100.87	97.40	100.99
	50	20.48	21.49	27.17	26.17	29.08	39.47	40.09	41.46	43.64	92.76	89.28	92.88
	63	20.01	21.02	26.70	25.70	28.61	39.00	39.62	40.99	43.17	92.29	88.81	92.40

	i _n	TA 	 TF				
			IEC B5				
			132	160	150	200	225
225B	8	265.00	337.3	345.3	343.3	339.8	342.6
	10	249.31	321.6	329.6	327.6	324.1	326.9
	12.5	234.27	306.6	314.5	312.5	309.1	311.9
	16	90.92	163.2	171.2	169.2	165.7	168.5
	20	86.52	158.8	166.8	164.8	161.3	164.1
	25	82.29	154.6	162.6	160.6	157.1	159.9
	31.5	68.32	140.6	148.6	146.6	143.1	145.9
	40	64.25	136.5	144.5	142.5	139.0	141.9

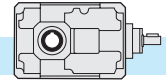





2.9 **Momenti d'inerzia** [Kg·cm²]
(riferiti all'albero veloce in entrata)



2.9 **Moments of inertia** [Kg·cm²]
(referred to input shaft)

2.9 **Trägheitsmoment** [Kg·cm²]
(bez. Antriebswelle)

TA..C - TC..C - TF..C

56C	i _n	TA 	TF 				
			IEC B5				
			56	63	71	80	90
40	0.06	0.136	0.139	0.212	0.410	0.588	
50	0.06	0.134	0.138	0.211	0.409	0.587	
63	0.06	0.134	0.137	0.210	0.408	0.586	
80	0.06	0.133	0.137	0.210	0.408	0.585	
100	0.06	0.129	0.132	0.205	0.403	0.581	
125	0.06	0.129	0.132	0.205	0.403	0.581	
160	0.06	0.128	0.132	0.205	0.403	0.581	
200	0.06	0.127	0.131	0.204	0.402	0.580	
250	0.06	0.127	0.131	0.204	0.402	0.580	

63C	i _n	TA 	TF 				
			IEC B5				
			56	63	71	80	90
40	0.07	0.142	0.145	0.218	0.416	0.594	
50	0.07	0.139	0.143	0.216	0.414	0.592	
63	0.07	0.138	0.142	0.215	0.413	0.590	
80	0.06	0.132	0.136	0.209	0.407	0.585	
100	0.06	0.132	0.135	0.208	0.406	0.584	
125	0.06	0.131	0.135	0.208	0.406	0.584	
160	0.06	0.131	0.135	0.208	0.406	0.583	
200	0.06	0.129	0.132	0.205	0.403	0.581	
250	0.06	0.129	0.132	0.205	0.403	0.581	
315	0.06	0.129	0.132	0.205	0.403	0.581	

75C	i _n	TA 	TF 			
			IEC B5			
			63	71	80	90
50	0.104	0.179	0.252	0.450	0.628	
63	0.098	0.173	0.246	0.444	0.622	
80	0.095	0.171	0.244	0.442	0.619	
100	0.070	0.145	0.219	0.417	0.594	
125	0.069	0.144	0.217	0.415	0.593	
160	0.068	0.143	0.216	0.414	0.592	
200	0.062	0.138	0.211	0.409	0.586	
250	0.062	0.137	0.210	0.408	0.586	

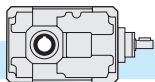







2.9 **Momenti d'inerzia** [Kg·cm²]
(riferiti all'albero veloce in entrata)

2.9 **Moments of inertia** [Kg·cm²]
(referred to input shaft)

2.9 **Trägheitsmoment** [Kg·cm²]
(bez. Antriebswelle)

TA..C - TC..C - TF..C

80C	i _n	TA 	TC 				TF 			
			IEC B5				IEC B5			
			63	71	80	90	63	71	80	90
50	0.90	0.95	1.09	1.47	1.52	1.15	1.17	1.84	2.91	
63	0.86	0.91	1.05	1.43	1.48	1.11	1.13	1.81	2.87	
80	0.86	0.91	1.05	1.43	1.48	1.11	1.13	1.80	2.87	
100	0.36	0.41	0.55	0.93	0.98	0.62	0.63	1.31	2.38	
125	0.35	0.38	0.52	0.90	0.95	0.61	0.62	1.30	2.37	
160	0.35	0.40	0.54	0.92	0.97	0.61	0.62	1.30	2.36	
200	0.35	0.40	0.54	0.92	0.97	0.61	0.62	1.30	2.36	
250	0.19	0.22	0.36	0.74	0.79	0.44	0.46	1.14	2.20	
315	0.19	0.22	0.36	0.74	0.79	0.44	0.46	1.14	2.20	
400	0.19	0.22	0.36	0.74	0.79	0.44	0.46	1.14	2.20	
500	0.19	0.22	0.36	0.74	0.79	0.44	0.46	1.13	2.20	
630	0.19	0.22	0.36	0.74	0.79	0.44	0.46	1.13	2.20	

100C	i _n	TA 	TC 				TF 			
			IEC B5				IEC B5			
			71	80	90	110-112	71	80	90	110-112
50	2.68	3.08	3.25	3.63	4.47	3.53	3.67	4.84	7.01	
63	2.56	2.96	3.13	3.51	4.35	3.41	3.55	4.72	6.89	
80	2.53	2.94	3.11	3.49	4.33	3.39	3.52	4.70	6.87	
100	1.14	1.51	1.68	2.06	2.89	2.00	2.13	3.31	5.47	
125	1.10	1.47	1.64	2.02	2.86	1.96	2.10	3.27	5.44	
160	1.10	1.47	1.64	2.02	2.86	1.96	2.09	3.27	5.44	
200	1.10	1.47	1.64	2.01	2.85	1.95	2.09	3.26	5.43	
250	0.64	0.98	1.15	1.52	2.36	1.50	1.63	2.81	4.98	
315	0.64	0.97	1.14	1.52	2.36	1.50	1.63	2.81	4.98	
400	0.64	0.97	1.14	1.52	2.36	1.50	1.63	2.81	4.98	
500	0.63	0.97	1.14	1.51	2.35	1.49	1.62	2.80	4.97	
630	0.63	0.97	1.14	1.51	2.35	1.49	1.62	2.80	4.97	

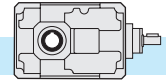







2.9 **Momenti d'inerzia** [Kg·cm²]
(riferiti all'albero veloce in entrata)

2.9 **Moments of inertia** [Kg·cm²]
(referred to input shaft)

2.9 **Trägheitsmoment** [Kg·cm²]
(bez. Antriebswelle)

TA..C - TC..C - TF..C

	i _n	TA 	TC 				TF 			
			IEC B5				IEC B5			
			80	90	110-112	132	80	90	110-112	132
125C	50	7.82	8.75	8.62	9.57	12.71	10.16	10.08	12.40	26.40
	63	7.46	8.39	8.26	9.22	12.36	9.80	9.73	12.04	26.04
	80	7.39	8.32	8.19	9.14	12.28	9.72	9.65	11.97	25.96
	100	3.44	4.28	4.15	5.10	8.24	5.77	5.70	8.02	22.01
	125	3.34	4.18	4.05	5.00	8.14	5.67	5.60	7.92	21.91
	160	3.32	4.16	4.03	4.98	8.12	5.65	5.58	7.90	21.89
	200	3.31	4.15	4.02	4.97	8.11	5.65	5.57	7.89	21.89
	225	3.31	4.15	4.02	4.97	8.11	4.08	4.01	6.33	20.32
	250	1.78	2.49	2.36	3.31	6.45	4.11	4.04	6.36	20.35
	315	1.77	2.48	2.35	3.31	6.45	4.11	4.04	6.35	20.35
	400	1.77	2.48	2.35	3.30	6.44	4.11	4.03	6.35	20.35
	450	1.77	2.48	2.35	3.30	6.44	4.10	4.03	6.35	20.35
	500	1.75	2.46	2.33	3.28	6.42	4.08	4.01	6.33	20.32
	550	1.75	2.46	2.33	3.28	6.42	4.08	4.01	6.33	20.32
630	1.75	2.46	2.33	3.28	6.42	4.08	4.01	6.33	20.32	

	i _n	TA 	TC 						TF 					
			IEC B5						IEC B5					
			80	90	110-112	132	160	180	80	90	110-112	132	160	180
160C	50	23.13	24.26	24.13	24.27	27.47	31.89	34.91	25.33	27.71	27.88	42.74	44.92	90.19
	63	22.01	23.14	23.01	23.15	26.35	30.77	33.79	24.21	26.59	26.77	41.63	43.81	89.07
	80	21.76	22.89	22.76	22.90	26.10	30.52	33.54	23.96	26.34	26.51	41.37	43.56	88.82
	100	8.65	9.61	9.48	9.62	12.82	17.24	20.26	10.85	13.23	13.40	28.26	30.45	75.71
	125	8.35	9.30	9.17	9.31	12.51	16.94	19.95	10.54	12.92	13.10	27.96	30.14	75.41
	160	8.28	9.23	9.10	9.24	12.44	16.87	19.88	10.47	12.86	13.03	27.89	30.07	75.34
	200	8.26	9.21	9.09	9.22	12.42	16.85	19.87	10.46	12.84	13.01	27.87	30.05	75.32
	225	8.25	9.20	9.08	9.21	12.41	16.84	19.86	10.44	12.83	13.00	27.86	30.04	75.31
	250	4.26	4.92	4.79	4.93	8.13	12.55	15.57	6.46	8.84	9.01	23.87	26.05	71.32
	315	4.24	4.90	4.77	4.91	8.11	12.53	15.55	6.44	8.82	9.00	23.86	26.04	71.30
	400	4.24	4.90	4.77	4.91	8.11	12.53	15.55	6.43	8.81	8.99	23.85	26.03	71.30
	450	4.23	4.89	4.76	4.90	8.10	12.52	15.54	6.43	8.81	8.99	23.85	26.03	71.29
	500	4.17	4.83	4.70	4.84	8.03	12.46	15.48	6.36	8.74	8.92	23.78	25.96	71.23
	550	4.16	4.82	4.69	4.83	8.03	12.46	15.47	6.36	8.74	8.92	23.78	25.96	71.22
630	4.16	4.82	4.69	4.83	8.03	12.45	15.47	6.36	8.74	8.92	23.78	25.96	71.22	

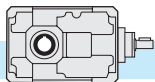

2.9 **Momenti d'inerzia** [Kg·cm²]
(riferiti all'albero veloce in entrata)

2.9 **Moments of inertia** [Kg·cm²]
(referred to input shaft)

2.9 **Trägheitsmoment** [Kg·cm²]
(bez. Antriebswelle)

TA..C - TC..C - TF..C

	i_n	TA	TC						TF					
			IEC B5						IEC B5					
			80	90	110-112	132	160	180	80	90	110-112	132	160	180
			180C	50	23.76	24.89	24.76	24.90	28.10	32.52	35.54	25.95	28.34	28.51
63	22.45	23.58		23.45	23.59	26.79	31.21	34.23	24.65	27.03	27.20	42.06	44.25	89.51
80	22.17	23.30		23.17	23.31	26.51	30.93	33.95	24.37	26.75	26.93	41.79	43.97	89.23
100	20.94	22.07		21.94	22.07	25.27	29.70	32.72	23.13	25.51	25.69	40.55	42.73	88.00
125	8.71	9.67		9.54	9.68	12.88	17.30	20.32	10.91	13.29	13.47	28.33	30.51	75.77
160	8.39	9.35		9.22	9.36	12.56	16.98	20.00	10.59	12.97	13.14	28.00	30.18	75.45
200	8.05	9.01		8.88	9.02	12.22	16.64	19.66	10.25	12.63	12.81	27.67	29.85	75.11
250	4.35	5.01		4.88	5.02	8.22	12.64	15.66	6.55	8.93	9.10	23.96	26.14	71.41
315	4.27	4.93		4.80	4.94	8.14	12.56	15.58	6.47	8.85	9.02	23.88	26.06	71.33
400	4.18	4.84		4.72	4.85	8.05	12.48	15.50	6.38	8.76	8.94	23.80	25.98	71.25

	i_n	TA	TC					TF				
			IEC B5					IEC B5				
			110-112	132	160	180	200	110-112	132	160	180	200
			200C	40	72.31	74.90	80.58	79.58	82.49	92.88	91.93	93.29
50	71.70	74.28		79.97	78.97	81.87	92.26	91.31	92.68	94.86	143.98	140.50
63	71.11	73.69		79.38	78.38	81.28	91.67	90.72	92.09	94.27	143.39	139.91
80	70.63	73.22		78.90	77.90	80.81	91.20	90.24	91.61	93.79	142.91	139.43
100	26.74	29.50		35.19	34.19	37.09	47.48	46.35	47.72	49.90	99.02	95.54
125	26.58	29.34		35.03	34.02	36.93	47.32	46.19	47.56	49.74	98.86	95.38
160	26.45	29.21		34.90	33.89	36.80	47.19	46.06	47.43	49.61	98.73	95.25
200	12.17	14.44		20.12	19.12	22.03	32.42	31.78	33.15	35.33	84.45	80.97
250	12.13	14.40		20.09	19.08	21.99	32.38	31.74	33.11	35.29	84.41	80.93
315	12.09	14.37		20.05	19.05	21.96	32.35	31.71	33.07	35.25	84.37	80.90

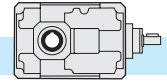

2.10 Dimensioni

2.10 Dimensions

2.10 Abmessungen

TF56B...

2 Riduzioni/Stages/Stufen

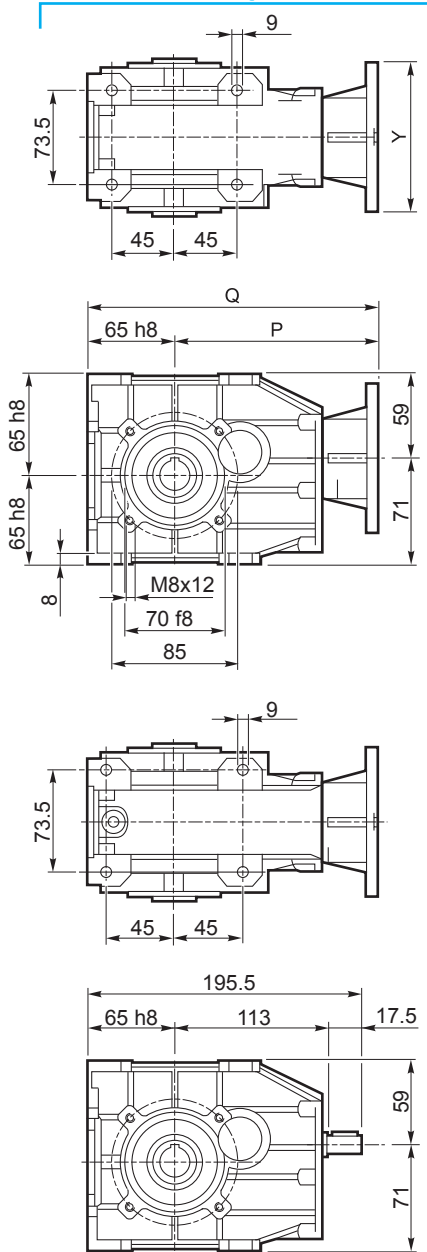

TF56C...

3 Riduzioni/Stages/Stufen

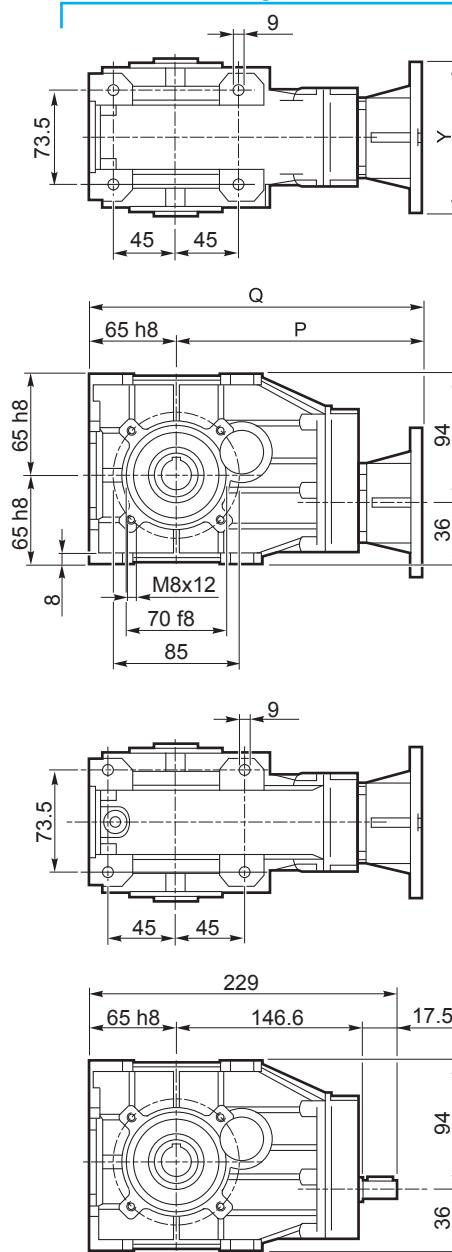

standard

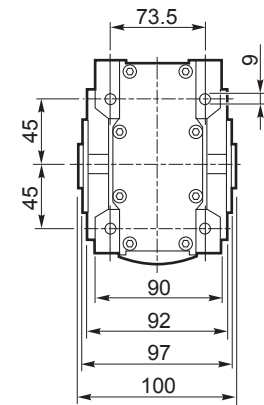
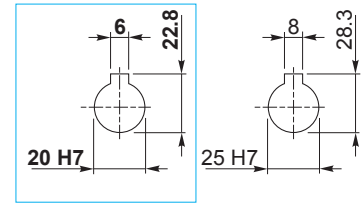

IEC	
	56 B5
	63 B5
	71 B5
	80 B5/B14
	90 B5/B14

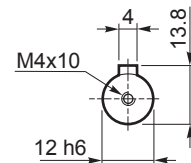

B5

IEC..	TF...									
	56B					56C				
Y	120	140	160	200	200	120	140	160	200	200
P	153	156	163	183	183	187	190	197	217	217
Q	218	221	228	248	248	252	255	262	282	282
kg	4.5	4.5	4.5	4.5	4.5	5.0	5.0	5.0	5.0	5.0

B14

IEC..	TF...									
	56B					56C				
Y	—	—	105	120	140	—	—	105	120	140
P	—	—	163	183	183	—	—	197	217	217
Q	—	—	228	248	248	—	—	262	282	282
kg	—	—	4.5	4.5	4.5	—	—	5.0	5.0	5.0

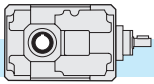

2.10 Dimensioni

2.10 Dimensions

2.10 Abmessungen

TF63B...

2 Riduzioni/Stages/Stufen

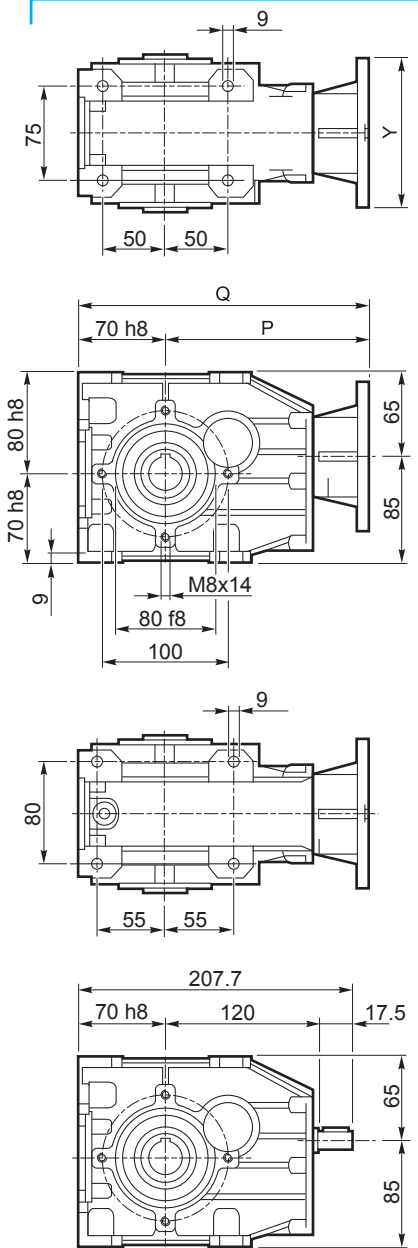

TF63C...

3 Riduzioni/Stages/Stufen

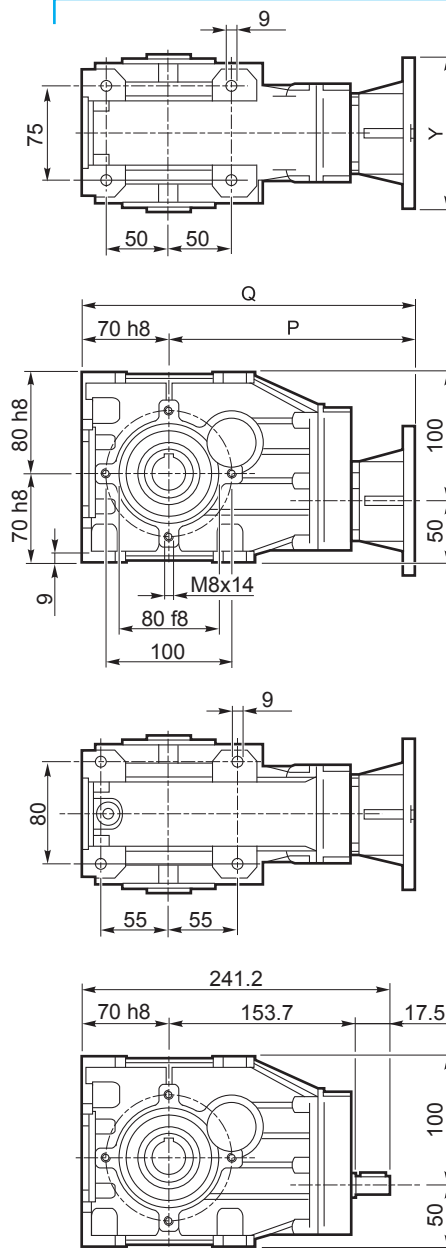

standard

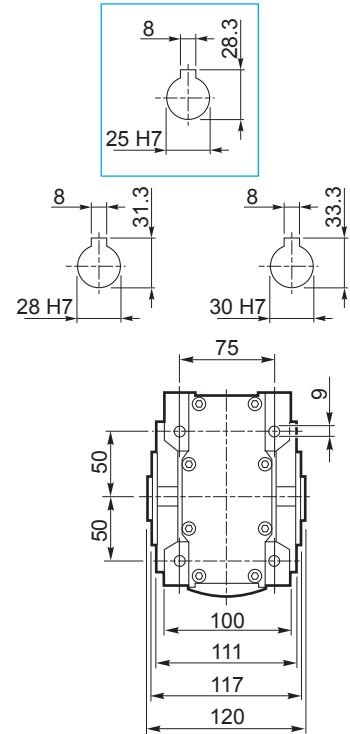

IEC	
	56 B5
	63 B5
	71 B5
	80 B5/B14
	90 B5/B14

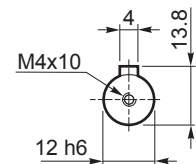

B5	TF...									
	63B					63C				
IEC..	56	63	71	80	90	56	63	71	80	90
Y	120	140	160	200	200	120	140	160	200	200
P	160	163	170	190	190	194	197	204	224	224
Q	230	233	240	260	260	264	267	274	294	294
kg	6.0	6.0	6.0	6.0	6.0	6.5	6.5	6.5	6.5	6.5

B14	TF...									
	63B					63C				
IEC..	56	63	71	80	90	56	63	71	80	90
Y	—	—	105	120	140	—	—	105	120	140
P	—	—	170	190	190	—	—	204	224	224
Q	—	—	240	260	260	—	—	274	294	294
kg	—	—	6.0	6.0	6.0	—	—	6.5	6.5	6.5

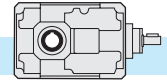

2.10 Dimensioni

2.10 Dimensions

2.10 Abmessungen

TF75B...

2 Riduzioni/Stages/Stufen

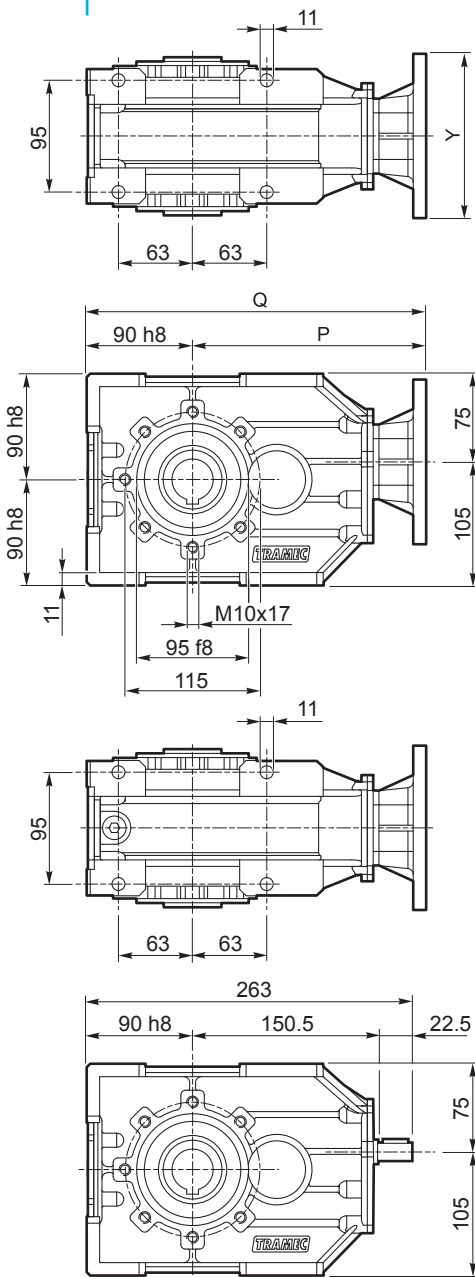

TF75C...

3 Riduzioni/Stages/Stufen

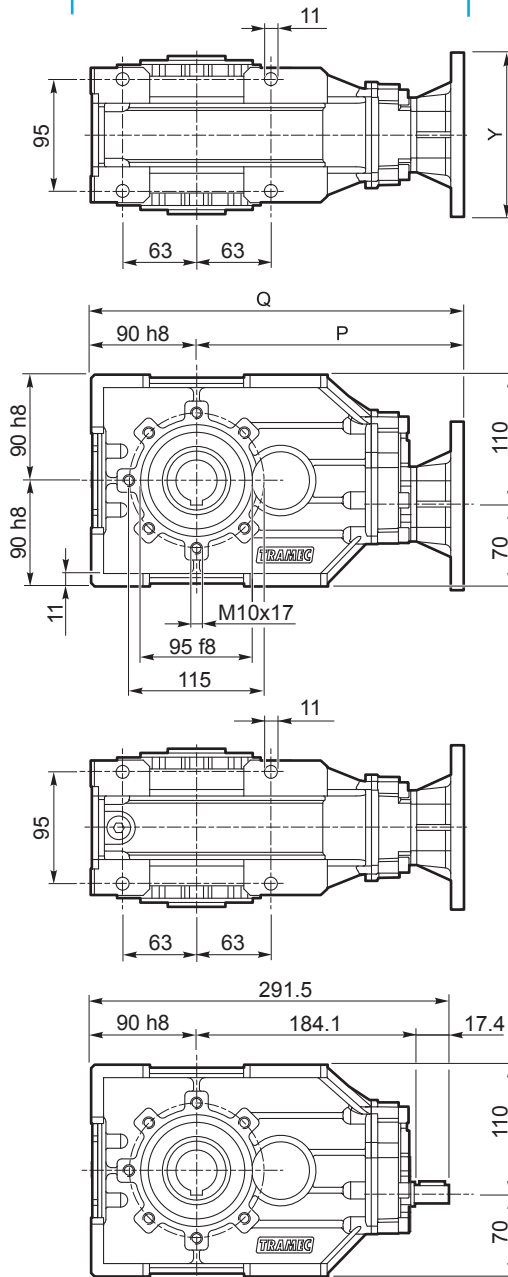

standard

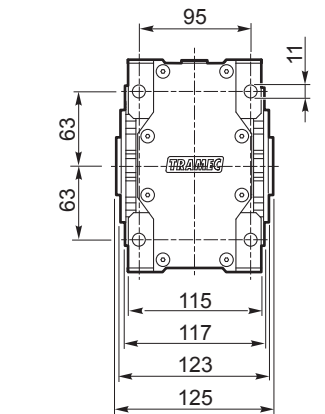
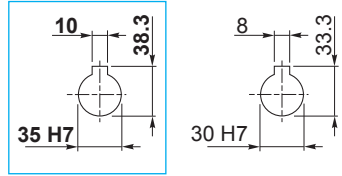

IEC	
	63 B5
71 B14	71 B5
	80 B5/B14
	90 B5/B14
	100 B5/B14

TA75B... TA75C...

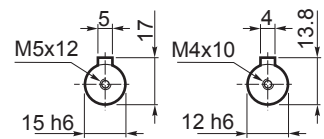

B5	TF...									
	75B					75C				
IEC..	71	80	90	100	112	63	71	80	90	
Y	160	200	200	250	250	140	160	200	200	
P	205.5	225.5	225.5	235.5	235.5	227	234	254	254	
Q	295.5	315.5	315.5	325.5	325.5	317	324	344	344	
kg	6.5	6.5	6.5	6.5	6.5	7	7	7	7	

B14	TF...									
	75B					75C				
IEC..	71	80	90	100	112	63	71	80	90	
Y	105	120	140	160	160	-	105	120	140	
P	205.5	225.5	225.5	235.5	235.5	-	234	254	254	
Q	295.5	315.5	315.5	325.5	325.5	-	324	344	344	
kg	6.5	6.5	6.5	6.5	6.5	7	7	7	7	

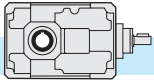

2.10 Dimensioni

2.10 Dimensions

2.10 Abmessungen

TA... - TC... - TF..																	
	71B			90B			112B			140B		180B		200B		225B	
A	142			180			224			280		360		400		450	
a	102			134			166			209		272.5		305		344	
a1	—			—			—			—		—		—		—	
B	112			127			150			175		215		255		290	
b	90			104			125			145		180		210		240	
C2	115			130			155			180		220		260		300	
D1 h6	14			19			24			28		38		38		48	
D2 H7	24	28	30	32	30	35	42	40	45	55	50	70	60	90	80	100	90
E	206			262			326			407		522.5		585		654	
e	38			52			64			82		110		120		140	
F	9			11			13			15		17		19		21	
f	M8x13			M10x16			M12x19			M14x22		M16x25		M18x35		M18x30	
G	122			155			194			244		320		350		400	
g	61			77.5			97			122		160		175		200	
H	71			90			112			140		180		200		225	
h	174			212			262			317		400		422.5		500	
I	110			130			160			190		237.5		237.5		296	
i	125			159.5			199			249		322.5		360		404	
L1	30			40			50			60		80		80		110	
O	64			82			102			127		162.5		185		204	
T	275			342			424			517		660		702.5		835	
t	211			260			322			390		497.5		517.5		631	
Z	9			11			13			16		20		22		25	

TA..														
kg	12.5		20		34		58		116		165		232	

TC... - TF...														
kg	15.5		25		44		75		136		185		270	

TC...												
	71B				90B				112B			
IEC	63 B5	71 B5	80/90 B5	80 B14	71 B5	80/90 B5	*90 B14	100/112 B5	80/90 B5	100/112 B5	132 B5	
Y	140	160	200	120	160	200	□ 120 / R73	250	200	250	300	
P	177	184	204	204	220	240	240	250	286	296	318	
p	113	120	140	140	138	158	158	168	184	194	216	
Q	248	255	275	275	310	330	330	340	398	408	430	
q	184	191	211	211	228	248	248	258	296	306	328	

	140B				180B				200B			
IEC	80/90 B5	100/112 B5	132 B5	160/180 B5	100/112 B5	132 B5	160/180 B5	200 B5	100/112 B5	132 B5	160/180 B5	200 B5
Y	200	250	300	350	250	300	350	400	250	300	350	400
P	331	341	363	393	413 / 423 (i=10-40) / (i=50-80)	433 / 443 (i=10-40) / (i=50-80)	463 / 473 (i=10-40) / (i=50-80)		435 / 445 (i=8-40) / (i=50-63)	455 / 465 (i=8-40) / (i=50-63)	485 / 495 (i=8-40) / (i=50-63)	
p	204	214	236	266	250 / 260 (i=10-40) / (i=50-80)	270 / 280 (i=10-40) / (i=50-80)	300 / 310 (i=10-40) / (i=50-80)		250 / 260 (i=8-40) / (i=50-63)	270 / 280 (i=8-40) / (i=50-63)	300 / 310 (i=8-40) / (i=50-63)	
Q	471	481	503	533	593 / 603 (i=10-40) / (i=50-80)	613 / 623 (i=10-40) / (i=50-80)	643 / 653 (i=10-40) / (i=50-80)		635 / 645 (i=8-40) / (i=50-63)	655 / 665 (i=8-40) / (i=50-63)	685 / 695 (i=8-40) / (i=50-63)	
q	344	354	376	406	430 / 440 (i=10-40) / (i=50-80)	450 / 460 (i=10-40) / (i=50-80)	480 / 490 (i=10-40) / (i=50-80)		450 / 460 (i=8-40) / (i=50-63)	470 / 480 (i=8-40) / (i=50-63)	500 / 510 (i=8-40) / (i=50-63)	

* Flange quadrate / Square flanges / Viereckige Flansche

TF...													
	71B			90B			112B			140B			
IEC	63 B5	71 B5	80/90 B5	71 B5	80/90 B5	100/112 B5	80/90 B5	100/112 B5	132 B5	80/90 B5	100/112 B5	132 B5	160/180 B5
Y	140	160	200	160	200	250	200	250	300	200	250	300	350
P	231	238	259	286	307	317	367	377	398	432	442	463	493
p	167	174	195	204	225	235	265	275	296	305	315	336	366
Q	302	309	330	376	397	407	479	489	510	572	582	603	633
q	238	245	266	294	315	325	377	387	408	445	455	476	506

	180B				200B				225B				
IEC	100/112 B5	132 B5	160/180 B5	200 B5	100/112 B5	132 B5	160/180 B5	200 B5	225 B5	132 B5	160/180 B5	200 B5	225 B5
Y	250	300	350	400	250	300	350	400	450	300	350	400	450
P	546	566	596	596	568.5	588.5	618.5	620.5	648.5	698	728	728	758
p	393.5	403	433	433	383.5	403.5	433.5	435.5	466.5	494	524	524	554
Q	736	746	776	776	768.5	788.5	818.5	820.5	848.5	923	953	953	985
q	573.5	583	613	613	583.5	603.5	633.5	635.5	663.5	774	749	749	779

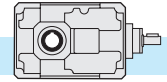

T..71B - T..225B

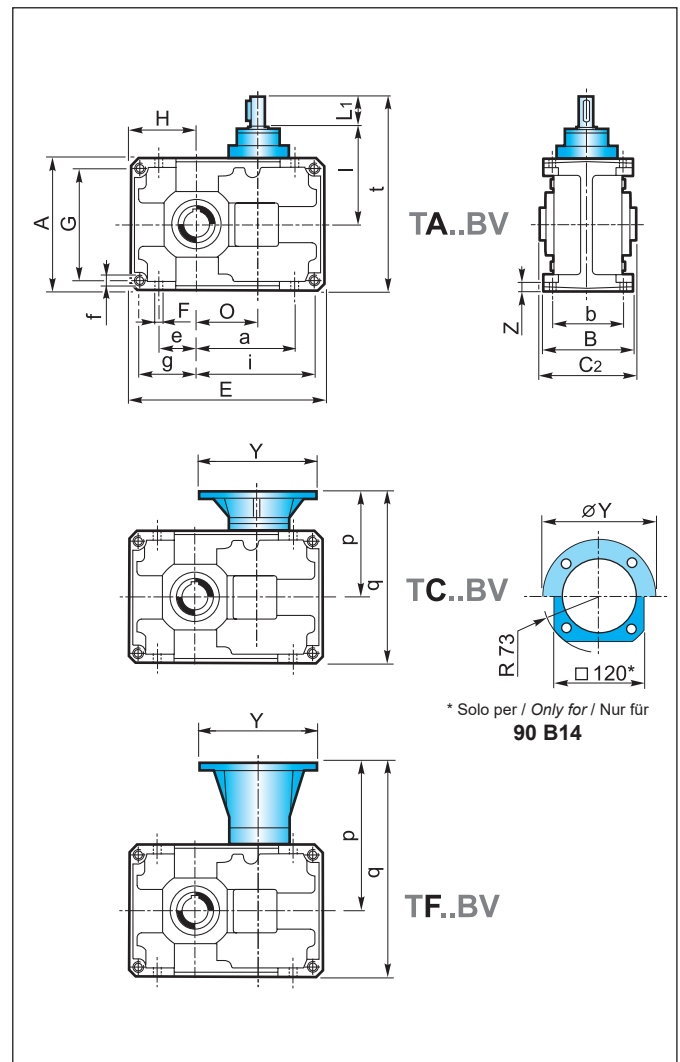
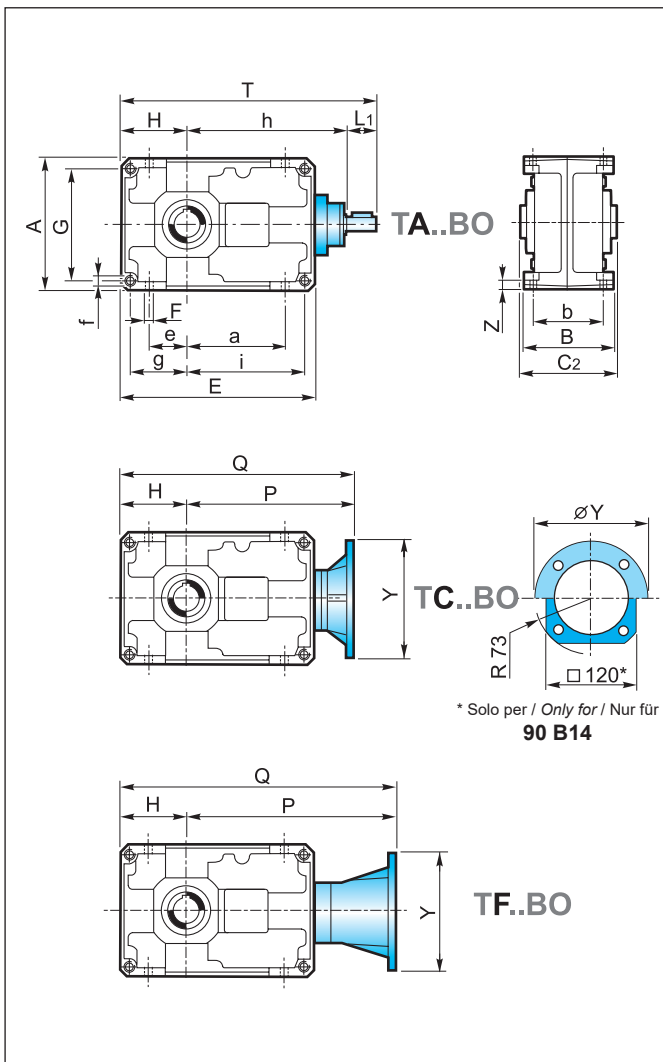

Albero uscita cavo
Hollow output shaft
Abtriebshohlwelle

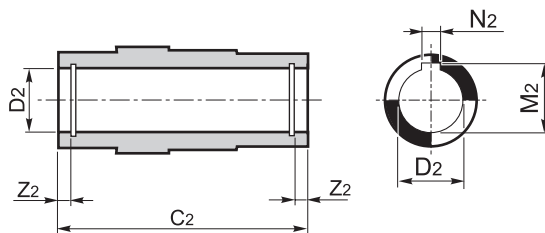

Albero entrata
Input shaft
Antriebswelle

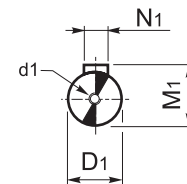

TA... - TC... - TF...

	71B							90B			112B			140B		180B		200B		225B	
D1 h6	14							19			24			28		38		38		48	
d1	M4x15							M8x22			M8x22			M8x22		M10x28		M10x28		M12x34	
M1	16							21.5			27			31		41		41		51.5	
N1	5							6			8			8		10		10		14	
C2	115							130			155			180		220		260		300	
D2 H7	24	28	30	32	30	35	42	40	45	55	50	70	60	90	80	100	90				
M2	27.3	31.3	33.3	35.3	33.3	38.3	45.3	43.3	48.8	59.3	53.8	74.9	64.4	95.4	85.4	106.4	95.4				
N2	8	8	8	10	8	10	12	12	14	16	14	20	18	25	22	28	25				
Z2	—			8.7	8.7	8.4	10.7	10.7	10.7	11.9	11.9	15.4	15.9	18.9	19.4	16.9	-				

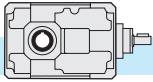

2.10 Dimensioni

2.10 Dimensions

2.10 Abmessungen

TA... - TC... - TF...														
	80C			100C			125C		160C		180C		200C	
A	160			200			250		320		360		400	
a	82			102			127		162.5		185		204	
a1	106			134			169		217		207		277.5	
B	127			150			175		215		255		290	
b	104			125			145		180		210		240	
C2	130			155			180		220		260		300	
D1 h6	14			19			24		28		28		38	
D2 H7	32	30	35	42	40	45	55	50	70	60	90	80	100	90
E	306			384			479		609.5		652		766.5	
e	42			52			67		90		100		115	
F	11			13			15		17		19		21	
f	M10x16			M12x19			M14x22		M16x25		M18x35		M18x30	
G	135			170			214		280		310		350	
g	67.5			85			107		140		155		175	
H	80			100			125		160		180		200	
h	256			314			389		479.5		502		604	
I	110			130			160		190		190		237.5	
i	213.5			269			336		429.5		447		541.5	
L1	30			40			50		60		60		80	
O	146			184			229		289.5		312		366.5	
T	366			454			564		699.5		742		884	
t	220			270			335		410		430		517.5	
Z	11			13			16		20		22		25	

TA..								
kg	19		36		66	120	170	260

TC... - TF...								
kg	22		41		76	137	190	295

TC...												
	80C				100C				125C			
IEC	63 B5	71 B5	80/90 B5	80 B14	71 B5	80/90 B5	*90 B14	100/112 B5	80/90 B5	100/112 B5	132 B5	
Y	140	160	200	120	160	200	□ 120 / R 73	250	200	250	300	
P	259	266	286	286	322	342	342	352	413	423	445	
p	113	120	140	140	138	158	158	168	184	194	216	
Q	339	346	366	366	422	442	442	452	538	548	570	
q	193	200	220	220	238	258	258	268	309	319	341	

	160C				180C				200C			
IEC	80/90 B5	100/112 B5	132 B5	160/180 B5	80/90 B5	100/112 B5	132 B5	160/180 B5	100/112 B5	132 B5	160/180 B5	200 B5
Y	200	250	300	350	200	250	300	350	250	300	350	400
P	493	503	525	555	516	526	548	578	$\frac{617}{(i=40-160)} / \frac{627}{(i=200-315)}$	$\frac{637}{(i=40-160)} / \frac{647}{(i=200-315)}$	$\frac{667}{(i=40-160)} / \frac{677}{(i=200-315)}$	
p	204	214	236	266	204	214	236	266	$\frac{250}{(i=40-160)} / \frac{260}{(i=200-315)}$	$\frac{270}{(i=40-160)} / \frac{280}{(i=200-315)}$	$\frac{300}{(i=40-160)} / \frac{310}{(i=200-315)}$	
Q	653	663	686	715	696	706	728	758	$\frac{617}{(i=40-160)} / \frac{627}{(i=200-315)}$	$\frac{837}{(i=40-160)} / \frac{647}{(i=200-315)}$	$\frac{867}{(i=40-160)} / \frac{877}{(i=200-315)}$	
q	364	374	396	426	384	394	416	446	$\frac{450}{(i=40-160)} / \frac{460}{(i=200-315)}$	$\frac{470}{(i=40-160)} / \frac{480}{(i=200-315)}$	$\frac{500}{(i=40-160)} / \frac{510}{(i=200-315)}$	

* Flange quadrate / Square flanges / Viereckige Flansche

TF...									
	80C			100C			125C		
IEC	63 B5	71 B5	80/90 B5	71 B5	80/90 B5	100/112 B5	80/90 B5	100/112 B5	132 B5
Y	140	160	200	160	200	250	200	250	300
P	313	320	341	388	409	419	494	504	525
p	167	174	195	204	225	235	265	275	296
Q	393	400	421	488	509	519	619	629	650
q	247	254	275	304	325	335	390	400	421

	160C				180C				200C			
IEC	80/90 B5	100/112 B5	132 B5	160/180 B5	80/90 B5	100/112 B5	132 B5	160/180 B5	100/112 B5	132 B5	160/180 B5	200 B5
Y	200	250	300	350	200	250	300	350	250	300	350	400
P	594	604	625	655	617	627	648	678	750	770	800	802
p	305	315	336	366	305	315	336	366	383.5	404	434	436
Q	754	764	785	815	797	807	828	858	950	970	1000	1002
q	465	475	496	526	485	495	516	546	583.5	604	634	636

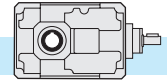

T..80C - T..200C

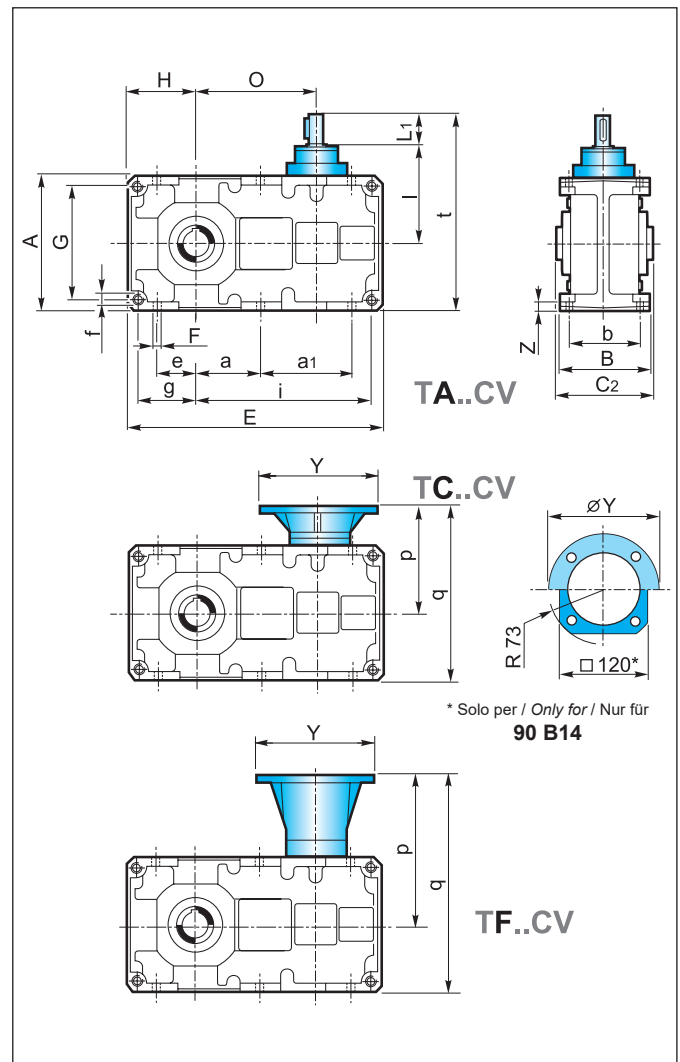
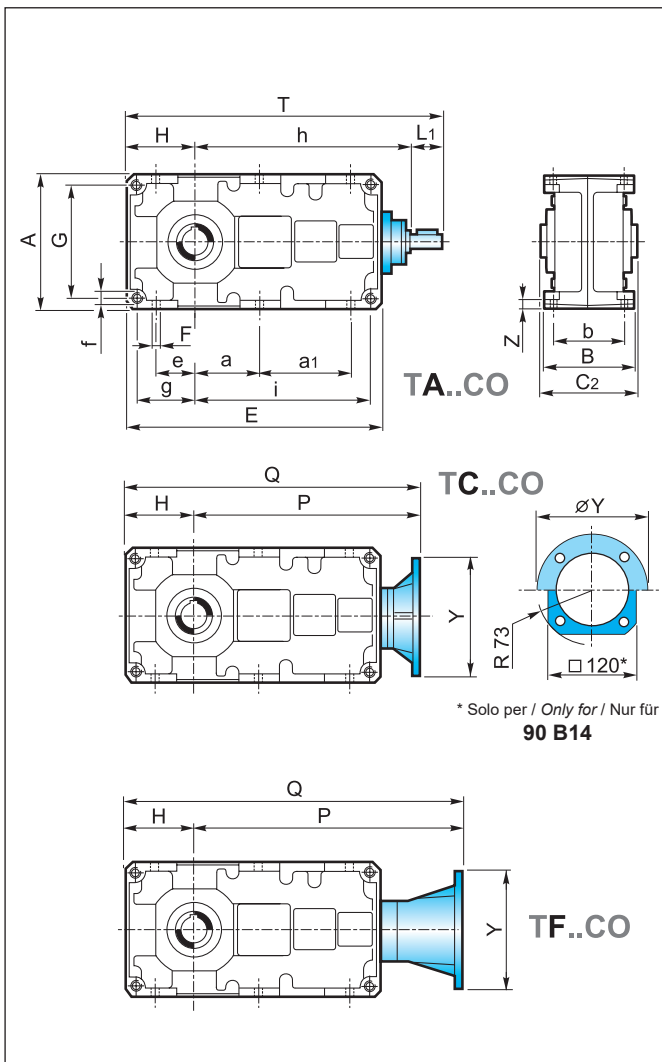

Albero uscita cavo
Hollow output shaft
Abtriebshohlwelle

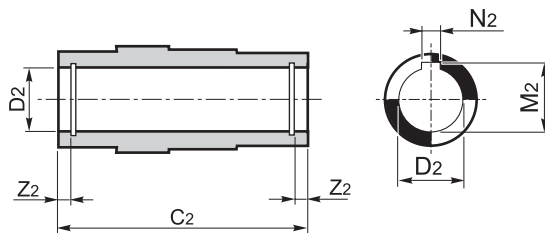

Albero entrata
Input shaft
Antriebswelle

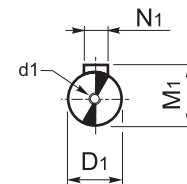

TA... - TC... - TF...

	80C		100C			125C		160C		180C		200C			
D1 h6	14		19			24		28		28		38			
d1	M4x15		M8x22			M8x22		M8x22		M8x22		M10x28			
M1	16		21.5			27		31		31		41			
N1	5		6			8		8		8		10			
C2	130		155			180		220		260		300			
D2 H7	32	30	35	42	40	45	55	50	70	60	90	80	100	90	
M2	35.3	33.3	38.3	45.3	43.3	48.8	59.3	53.8	74.9	64.4	95.4	85.4	106.4	95.4	
N2	10	8	10	12	12	14	16	14	20	18	25	22	28	25	
Z2	8.7		8.4			10.7		11.9		15.4		18.9		19.4	
														-	

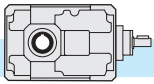

2.11 Accessori

2.11 Accessories

2.11 Zubehör

Albero lento

Output shaft

Abtriebswelle

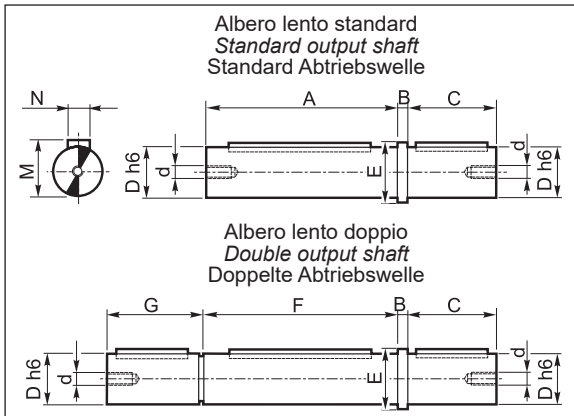

Materiale albero lento: **C45**
Output shaft material: **C45**
Material der Abtriebswelle: **C45**

	T											
	56B 56C	63B 63C	75B 75C	71B	90B 80C	112B 100C	140B 125C	180B 160C	200B 180C	225B 200C		
A	100	120	123	114	129	129	154	154	179	219	259	298
B	5	5	6	5	6	6	8	8	10	12	15	15
C	40	45	60	50	60	60	80	80	100	125	140	180
D _{h6}	20	25	35	24	32	35	42	45	55	70	90	100
d	M8	M8	M10	M8	M8	M8	M10	M10	M10	M12	M16	M18
E	26	32	43	30	40	43	50	53	65	80	110	118
F	100	120	125	115	130	—	155	—	180	220	260	300
G	41	46	60	49	59	—	79	—	99	124	141	178
M	22.5	28	38	27	35	38	45	48.5	59	74.5	95	106
N	6	8	10	8	10	10	12	14	16	20	25	28

**Kit fissaggio e smontaggio
riduttori con albero lento cavo
(escluso T 56, 63, 71 e 75)**

**Kit for the mounting and dismounting
of the gearboxes with hollow output
shaft (except T 56, 63, 71 and 75)**

**Kit für Montage und Ausbau der
Getriebe mit Abtriebshohlwelle
(außer dass T 56, 63, 71 und 75)**

	T												
	90B 80C			112B 100C			140B 125C		180B 160C		200B 180C		225B 200C
C2	130			155			180		220		260		300
D2	32	30	35	42	40	45	55	50	70	60	90	80	100
H	8	7	6.5	10	8		9		12		16	15.5	17
d1	—			—			M10		M12		M16		M18
d2	—			—			M8		M10		M12		M16
d3	M8			M8			—		—		—		—
d4	M12			M12			—		—		—		—
Z2	8.7		8.4	10.7			11.9		15.4	15.9	18.9	19.4	16.9
Lmax	111	112		131	133			156		189		221	262
Lmin	106	107		126	128			149		182		211	252

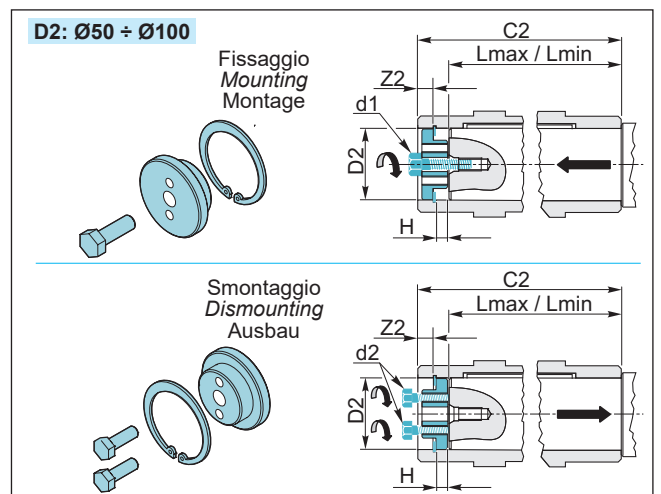
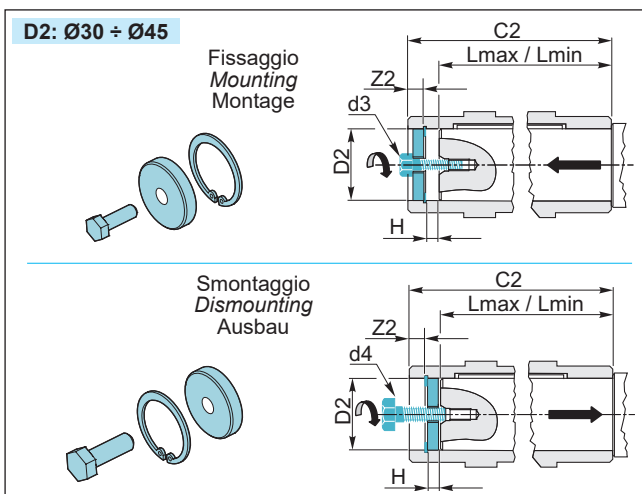

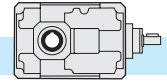

Albero lento cavo con calettatore

Hollow output shaft with shrink disc

Abtriebshohlwelle mit Schrumpfscheibe

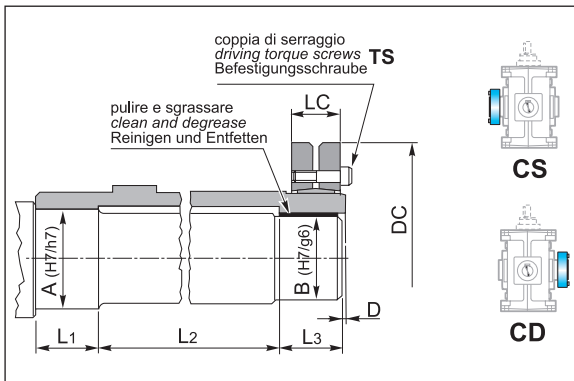

	T									
	56B 56C	63B 63C	75B 75C	71B	90B 80C	112B 100C	140B 125C	180B 160C	200B 180C	225B 200C
A	27	32	37	27	37	47	57	72	92	102
B	25	30	35	25	35	45	55	70	90	100
D	2	2	2	2	2	2	2	2	3	3
DC	60	72	80	60	80	100	115	155	188	215
LC	21.5	23.5	26	22	26	31	31	39	50	54
L ₁	32	36	39	36	39	45	50	60	70	80
L ₂	61	75	82	68	82	100	115	143	175	200
L ₃	32	36	39	36	39	45	50	60	70	80
TS(Nm)	4	12	12	4	12	12	12	30	59	59

Flangia uscita

Output flange

Abtriebsflansch

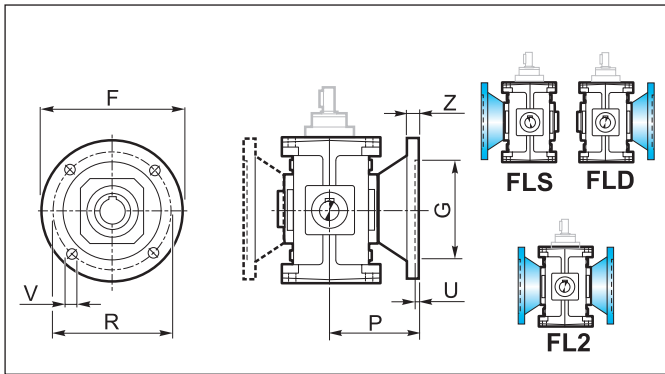

	T								
	56B 56C	63B 63C	75B 75C	71B	90B 80C	112B 100C	140B 125C	180B 160C	200B 180C
F	140	160	200	160	200	250	300	350	400
G _{F7}	95	110	130	110	130	180	230	250	300
R	115	130	165	130	165	215	265	300	350
P	82	91.5	97.5	87	100	125	150	180	215
U	5	5	5	4	4.5	5	5	6	6
V	9	9	12	12	12	14	16	18	20
Z	15	10	15	10	12	16	20	25	30
kg	0.5	0.5	0.9	2	3.2	5	8	12.5	24

Braccio di reazione

Torque arm

Drehmomentstütze

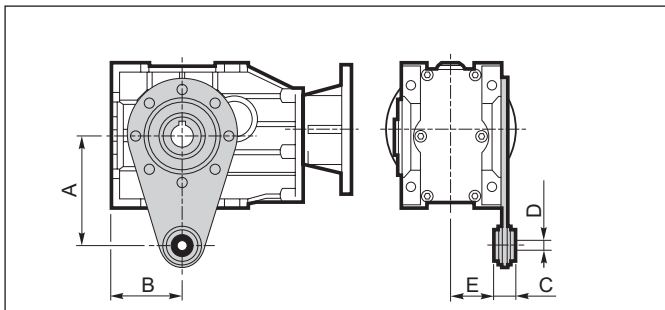

56B - 56C - 63B - 63C - 75B - 75C			
	T		
	56B 56C	63B 63C	75B 75C
A	100	150	200
B	65	70	90
C	20	20	25
D	10	10	20
E	39	48.5	49

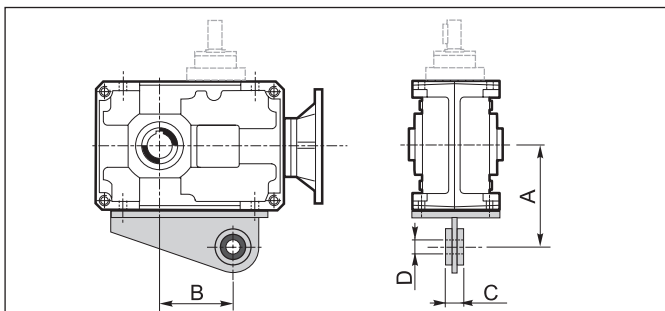

71B - 225B							
	T						
	71B	90B	112B	140B	180B	200B	225B
A	123	140	172	205	260	300	325
B	84	116	144	189	247.5	280	319
C	25	25	30	30	35	45	45
D	20	20	25	25	35	40	40

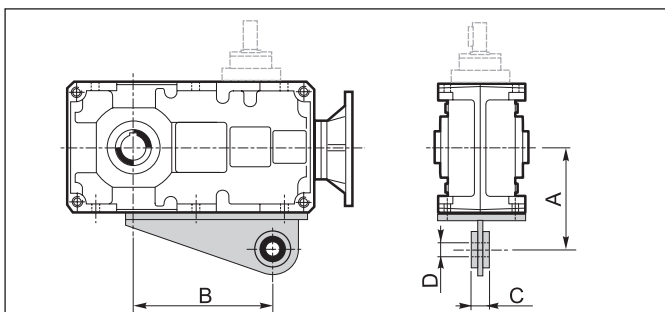

80C - 200C						
	T					
	80C	100C	125C	160C	180C	200C
A	130	160	190	240	280	300
B	170	214	276	354.5	367	456.5
C	25	30	30	35	45	45
D	20	25	25	35	40	40

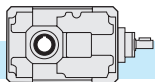

Kit protezione albero cavo

Ad esclusione delle grandezze 56, 63 e 75, a richiesta è possibile predisporre il riduttore con un kit di protezione dell'albero cavo. Tale protezione, essendo dotata di un'opportuna guarnizione, impedisce ad eventuali fluidi, presenti nell'ambiente di lavoro, di venire a contatto con l'albero cavo del riduttore oltre ad impedire il contatto con corpi estranei. Le dimensioni di ingombro sono riportate nella tabella seguente.

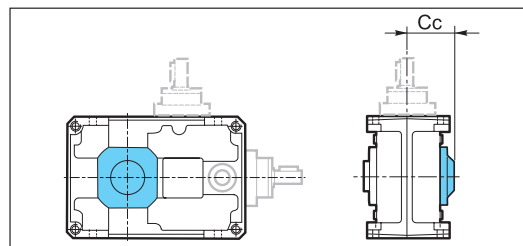

Dispositivo antiritorno

Il riduttore ad assi ortogonali presenta valori di rendimento statico (e dinamico) molto elevati: per questo motivo non è garantita spontaneamente l'irreversibilità statica. L'irreversibilità statica si realizza quando, a riduttore fermo, l'applicazione di un carico all'albero lento non pone in rotazione l'asse entrata. Pertanto, per garantire l'irreversibilità del moto, a riduttore fermo, occorre predisporre il riduttore stesso con un opportuno dispositivo antiritorno, fornibile a richiesta tranne che sulle grandezze T56, T63 e T75. Tale dispositivo permette la rotazione dell'albero lento solo nel senso desiderato, da specificare all'atto dell'ordine.

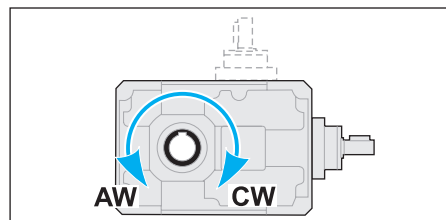

Nel caso in cui sia presente il dispositivo antiritorno è necessario l'utilizzo di olio lubrificante sintetico, classe di viscosità ISO 150.

Nella tabella seguente (tab. 3) sono indicati i valori dei momenti torcenti nominali massimi (T_{2Mmax}), riferiti all'albero uscita, garantiti dal dispositivo di antiritorno, per ogni rapporto di riduzione e per ogni grandezza di riduttore. Se, in corrispondenza dell'albero lento, viene applicata una coppia maggiore di quella indicata, l'irreversibilità del moto non è più garantita. Questi valori di coppia non sono da confondere con quelli riportati nella tabella riguardante i dati tecnici dei riduttori. Infatti, si noti come in tabella siano stati messi in evidenza i valori di coppia garantiti (in uscita) dal dispositivo antiretro che risultano essere minori dei massimi valori di coppia motrice trasmissibili, con fattore di servizio $F_s = 1$, dal riduttore.

Vedere paragrafo 1.5 per la verifica del dispositivo antiritorno.

Hollow shaft protection kit

On request we can supply a hollow shaft protection kit (except for sizes 56, 63 and 75).

The kit features a gasket which prevents any contact between hollow shaft and foreign bodies or fluids existing in the working environment. Over-all dimensions are reported in the following table.

Cc	T						
	71B	90B 80C	112B 100C	140B 125C	180B 160C	200B 180C	225B 200C
Cc	79.5	87	105	120.5	141.5	167.5	191.5

Backstop device

Bevel helical gearboxes feature quite high values of static (and dynamic) efficiency: for this reason spontaneous static irreversibility is not guaranteed. Static irreversibility, with motionless gearbox, occurs when the application of a load on the output shaft does not cause rotation of the input axis. In order to guarantee motion irreversibility, with motionless gearbox, it is necessary to fit a backstop device, which is available on request, except for sizes 56, 63 and 75.

The backstop device enables rotation of the output shaft only in the required direction, which is to be specified when ordering.

CW Rotazione oraria
Clockwise rotation
Im Uhrzeigersinn

AW Rotazione antioraria
Anti-clockwise rotation
Gegen den Uhrzeigersinn

The utilization of synthetic oil, viscosity class ISO 150, is necessary for the gearboxes equipped with back stop device.

The following table (tab.3) shows the max. rated torques (T_{2Mmax}) at gearbox output guaranteed by the backstop device, for each ratio and each gearbox size. If a higher torque is applied at gearbox output, motion irreversibility is no longer guaranteed.

These torque values are not to be confused with the values reported in the gearbox specifications tables.

Please note that the torque values guaranteed (at output) by the backstop device are lower than the max. driving torque values transmissible by the gearbox, with service factor $F_s = 1$.

To check the back stop device pls see paragraph 1.5.

Schutzvorrichtung für die Hohlwelle

Auf Wunsch ist eine Schutzvorrichtung für die Hohlwelle lieferbar (Größen 56, 63 und 75 ausgenommen).

Die Schutzvorrichtung weist eine Dichtung auf, die zur Vermeidung von irgendwelchem Kontakt zwischen Hohlwelle und Fremdkörper oder Flüssigkeiten der Arbeitsumgebung dient. Den Tabelle wird der Raumbedarf angegeben.

Rücklaufsperre

Kegelstirnradgetriebe haben sehr hohen statischen (und dynamischen) Wirkungsgrad: deshalb wird keine spontane statische Irreversibilität garantiert. Statische Irreversibilität bei stillstehenden Getriebe hat man, wenn die Applikation mit einer Last auf die Abtriebswelle keine Drehung der Antriebswelle verursacht. Um Irreversibilität der Bewegung bei stillstehendem Getriebe zu sichern, sollte eine Rücklaufsperre montiert werden. Die Rücklaufsperre wird auf Wunsch geliefert (Größen 56, 63 und 75 ausgenommen). Die Rücklaufsperre ermöglicht, dass die Abtriebswelle nur in der gewünschten Richtung dreht (gewünschte Richtung beim Bestellen angeben).

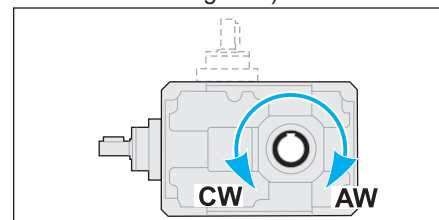

Getriebe mit einer Rücklaufsperre müssen mit synthetischem Öl (Viskosität ISO150) betrieben werden.

In der folgenden Tabelle (Tab. 3) werden die max. Nenndrehmomente am Abtrieb angegeben (T_{2Mmax}), die die Rücklaufsperre je nach Untersetzungsverhältnis und Getriebegröße garantiert. Falls am Abtrieb ein höheres Drehmoment eingesetzt wird, dann ist die Irreversibilität der Bewegung nicht mehr garantiert.

Diese Drehmomente sind nicht mit den Werten zu verwechseln, die in der Tabelle der technischen Daten der Getriebe angegeben werden.

Die von der Rücklaufsperre (am Abtrieb) garantierten Drehmomente sind niedriger als die von den Getrieben übersetzbaren max. Drehmomente, unter Berücksichtigung eines Betriebsfaktors $F_s = 1$.

Überprüfung der Rücklaufsperre siehe Abschnitt 1.5.

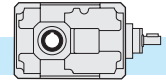

Coppia massima garantita in uscita dal dispositivo antiritorno
Max. output torque guaranteed by the backstop device
Von der Rücklaufsperrre garantierten max. Abtriebsdrehmomente

Tab. 3

T	in																
	5*	6.3*	7*	8	10	12.5	16	18	20	25	31.5	35	40	50	63	70	80
	T_{2M} max [Nm]																
71B	—	—	—	—	213	272	325	—	213	271	325	—	421	272	325	—	421
90B	148	204	—	—	333	424	508	—	333	424	508	—	657	424	508	—	657
112B	326	—	—	—	733	934	1118	—	733	933	1119	—	1446	933	1118	—	1446
140B	—	—	1038	—	1547	1969	2358	2630	1547	1968	2359	2630	3051	1968	2359	2630	3050
180B	—	—	—	—	3009	3831	4588	5115	3009	3829	4589	5115	5935	3829	4589	5115	5934
200B	—	—	—	5937	7607	9189	11399	—	12873	9190	11402	—	12875	11401	12875	—	—
225B	—	—	—	9856	11829	14538	9858	—	11838	14536	14537	—	17800	—	—	—	—

T	in															
	40	50	63	80	100	125	160	200	225	250	315	400	450	500	550	630
	T_{2M} max [Nm]															
80C	—	1086	1301	1656	1086	1301	1656	1985	—	1301	1656	1985	—	2567	—	3319
100C	—	1697	2033	2588	1697	2033	2588	3101	—	2033	2588	3101	—	4010	—	5186
125C	—	3733	4474	5694	3733	4473	5693	6822	7605	4473	5693	6822	7605	8822	9836	11410
160C	—	7874	9435	12008	7873	9435	12008	14388	16042	9434	12008	14388	16042	18607	20747	24064
180C	—	7874	9435	12008	7873	9435	12008	14388	—	9434	12008	14388	—	18607	—	24064
200C	12511	15024	18453	22586	15023	18450	22594	15024	—	18452	22594	—	—	—	—	—

* Rapporti speciali / *Special ratios* / Sonderverhältnisse

Valori di coppia garantiti inferiori alla T_{2M}

Torque values guaranteed lower than T_{2M} value

Zuverlässige Drehmomente unter T_{2M} Wert

Dimensioni riferite alla versione con antiretro

Dimensions of the version with backstop device

Abmessungen der Version mit Rücklaufsperrre

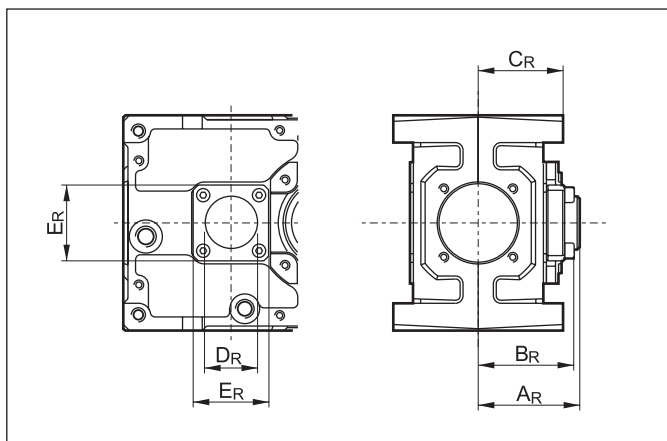

	A _R	B _R	C _R	D _R	E _R
T 71B	67	63	56	35	50
T 80C	67	63	63.5	45	60
T 90B	73	68	63.5	45	60
T 100C	71.5	70	75	55	80
T 112B	90	83	75	55	80
T 125C	86.5	96.5	87.5	60	90
T 140B	108	95	87.5	70	90
T 160C	106.5	101	107.5	70	100
T 180B	122	113	107.5	80	110
T180C	110.5	110	127.5	70	100
T200B	163	137.5	127.5	90	160
T 200C	125	124	145	90	130
T 225B	169	147	145	110	155

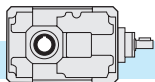

2.12 Giochi angolari

Bloccando l'albero di entrata, il gioco viene misurato sull'albero uscita ruotandolo nelle due direzioni ad applicando la coppia strettamente necessaria a creare il contatto tra i denti degli ingranaggi, al massimo pari al 2% della coppia massima garantita dal riduttore (T_{2M}). Nella tabella seguente sono riportati i valori indicativi del gioco angolare (in minuti di angolo) per quanto riguarda il montaggio normale. I valori ottenibili con una registrazione più precisa sono di poco inferiori di uno o due primi. Quest'ultima esecuzione è da utilizzare solo in caso di reale necessità in quanto potrebbe comportare un leggero aumento della rumorosità e rendere meno efficace l'azione dell'olio lubrificante.

2.12 Angular backlash

After having blocked the input shaft the angular backlash can be measured on the output shaft by rotating it in both directions and applying the torque which is strictly necessary to create a contact between the teeth of the gears. The applied torque should be at most 2% of the max. torque guaranteed by the gearbox. (T_{2M}). The following table reports the approximate values of the angular backlash (in minutes of arc) referred to standard mounting. The values that can be obtained with a more precise recording are slightly lower than one or two primes or two minutes of arc. The latter solution should be adopted only in case of necessity because it may rise the noise level and lessen the action of the lubricant.

2.12 Winkelspiel

Nachdem die Antriebswelle blockiert worden ist, darf das Winkelspiel auf die Abtriebswelle bemessen werden. Dabei soll die Abtriebswelle in beiden Richtungen gedreht und ein Drehmoment ausgeübt werden, dass zur Entstehung eines Kontaktes zwischen den Zähnen genügt. Das ausgeübte Drehmoment soll höchstens 2% des max. vom Getriebe garantierten Drehmoment (T_{2M}) sein. Die folgende Tabelle weist die Näherungswerte des Winkelspiels (in Bogenminuten) für Standardmontage. Die mit einer genaueren Feineinstellung erhältlichen Werte sind um wenig geringer als 1 oder 2 Winkelminuten. Die präzise Lösung darf nur im Notfall angewendet werden, weil infolgedessen der Geräuschpegel zunimmt und die Wirkung des Schmiermittels abnimmt.

T	Gioco angolare massimo / Maximum Backlash / maximales Winkelspiel (1')
56B / 56C / 63B / 63C / 75B / 75C 71B / 90B / 80C / 112B / 100C	20'
140B / 125C / 180B / 160C / 200B / 180C / 225B / 200C	15'

2.13 Lubrificazione

I riduttori ad assi ortogonali (ad esclusione dei tipi T56, T63 e T75, con lubrificazione a vita) sono forniti predisposti per lubrificazione a olio e muniti dei tappi di carico, livello e scarico olio. Si raccomanda di precisare sempre la posizione di montaggio desiderata in fase di ordine.

POMPA DI LUBRIFICAZIONE.

Una pompa per lubrificazione forzata dei cuscinetti superiori è fornita a richiesta sulle grandezze 112, 125, 140, 160, 180, 200 e 225 nella posizione di montaggio VA.

Nelle posizioni di montaggio in cui sono presenti cuscinetti posti al di sopra del livello dell'olio lubrificante è prevista l'applicazione di grasso speciale su tali cuscinetti per migliorarne la lubrificazione. E' possibile dotare gli stessi cuscinetti di un anello metallico (nylos) con la funzione di contenimento del grasso e, di conseguenza, di prolungare l'effetto nel tempo. Questa soluzione viene fornita su specifica richiesta.

2.13 Lubrication

Bevel helical gearboxes (except for T56, T63 and T75 which are lubricated for life) require oil lubrication and are equipped with filler, level and drain plugs. The mounting position should always be specified when ordering the gearbox.

OIL PUMP.

A pump for forced lubrication of the upper bearings is supplied on request for sizes 112, 125, 140, 160, 180, 200 and 225 in the VA mounting position.

Depending on the mounting position, the bearings may be lodged above the lubricant level. In this case it is necessary to apply special grease on the bearings in order to improve their lubrication. A metallic ring (nylos) can be fitted on the bearings it keeps the grease in place thus prolonging the action. It is supplied on specific request.

2.13 Schmierung

Die Kegelstirnradgetriebe sind für die Ölschmierung mit Einfüll-, Ölstand- und Ablassstopfen versehen. Bei der Bestellung ist immer die gewünschte Montageposition anzugeben.

ÖLPUMPE.

Eine Pumpe für die Zwangsschmierung der oberen Lager kann auf Wunsch bei den Größen 112, 125, 140, 160, 180, 200 und 225 in der Montageposition VA geliefert werden.

Abhängig von der Einbaulage kann es sein, dass die Lager über dem Ölstand liegen. In dem Fall wird Sonderfett auf die Lager geschmiert, um deren Schmierung zu verbessern. Ein metallischer Ring (nylos) für die Lager kann auf Wunsch geliefert werden: er hält das Fett fest und verlängert die Lebensdauer.

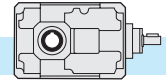

Posizione di montaggio e quantità di lubrificante (litri)

I quantitativi di olio riportati nelle varie tabelle sono indicativi e riferiti alle posizioni di lavoro indicate e considerando le condizioni di funzionamento a temperatura ambiente e velocità in ingresso di 1400 min⁻¹. Per condizioni di lavoro diverse da quelle sopra riportate contattare il servizio tecnico.

Mounting positions and lubricant quantity (liters)

The oil quantities stated in the tables are approximate values and refer to the indicated working positions, considering operating conditions at ambient temperature and an input speed of 1400 min⁻¹. Should the operating conditions be different, please contact the technical service.

Montageposition und Ölmenge (liter)

Die in der Tabellen angegebenen Daten sind Richtwerte. Die Ölmengen beziehen sich auf die angegebenen Betriebspositionen. Dabei wird den Betrieb bei Umgebungstemperatur und Antriebsdrehzahl von 1400 min⁻¹ berücksichtigt. Falls die Betriebsbedingungen anders sind, dann ist das technische Büro zu befragen.

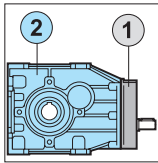
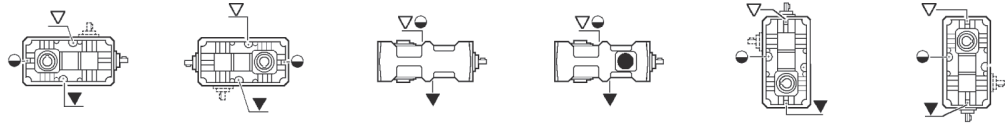

	T	B3	B8	B6	B7	VA	VB
②	56B			0.30			0.30
①	56C				0.05		
②	56C					0.40	0.30
②	63B			0.30			
②	63B			0.35		0.45	0.35
①	63C				0.05		
②	63C			0.35		0.45	0.35
②	75B				0.45		
①	75C				0.08		
②	75C				0.45		
	71B	0.6		0.7	0.5		0.8
	80C	1.1		1.5	1.3		1.5
	90B	1.0		1.4	1.2		1.3
	100C	2.0		2.6	2.3		2.8
	112B	1.8		2.6	2.3		2.4
	125C	3.8		4.8	4.5		5.0
	140B	3.6		4.6	4.3		4.3
	160C	7.0		9.2	8.7		10.0
	180B	7.5		9.7	9.2		8.0
	180C	9.5		14.0	13.0		15.5
	200B	12.5		15.0	14.0		17.5
	200C	13.5		19.0	18.0		19.5
	225B	14.5		19.0	18.0		18.7

* Nella posizione di montaggio B6-B7 è previsto un tappo di sfiato con asta di livello, tranne T 56, 63 e 75.
 * In mounting position B6-B7 the breather plug is supplied complete with the dipstick, except T 56, 63 and 75.
 * Für die Version B6-B7 ist eine Entlüftungsschraube mit Ölstandsanzeige vorgesehen, außer dass T 56, 63 und 75.

Posizione morsetti

Terminal board position

Lage des Klemmenkastens

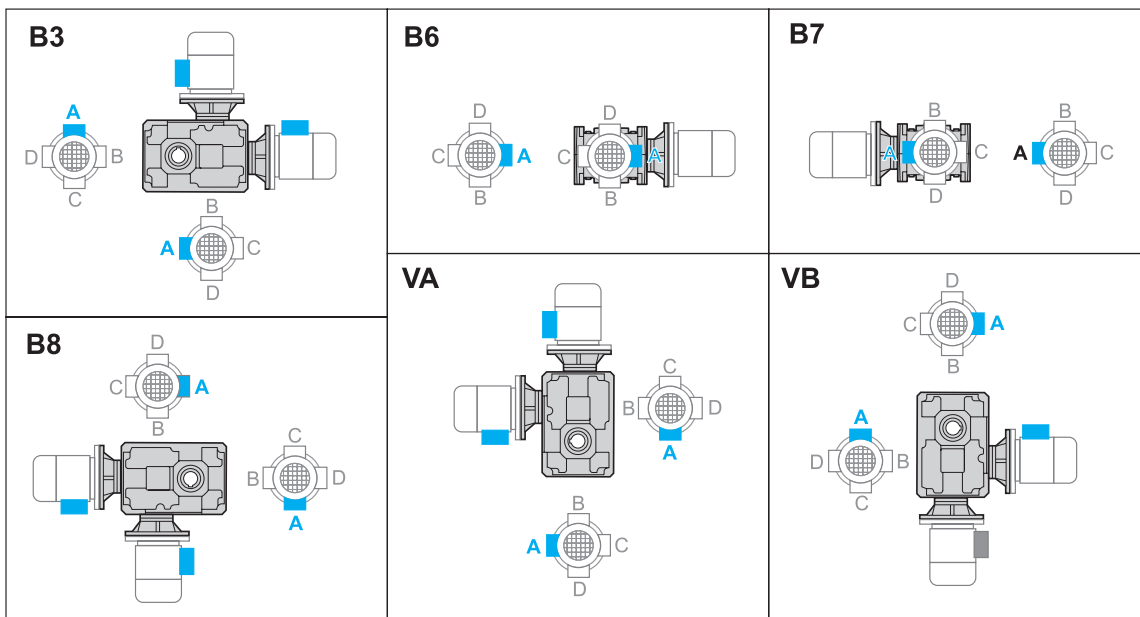

N.B. Se non diversamente specificato, il motore verrà fornito con la morsetti in posizione A.

N.B. Unless otherwise agreed, the motor will be supplied with the terminal board in position A.

ANMERKUNG: Ausser wenn anders angegeben, wird der Motor mit Klemmenkasten in der A Position geliefert.

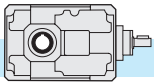

2.14 Carichi radiali e assiali (N)

Le trasmissioni effettuate tramite pignoni per catena, ruote dentate o pulegge generano delle forze radiali (F_R) sugli alberi dei riduttori. L'entità di tali forze può essere calcolata con la formula:

2.14 Radial and axial loads (N)

Transmissions implemented by means of chain pinions, wheels or pulleys generate radial forces (F_R) on the gear unit shafts. The entity of these forces may be calculated using the following formula:

2.14 Radial- und Axialbelastungen (N)

Antriebe mit Kettenritzel, Zahnrädern oder Riemscheiben erzeugen radiale Kräfte (F_R) an den Wellen der Untersetzungsgetriebe. Das Ausmaß dieser Kräfte kann nach folgender Formel berechnet werden:

$$F_R = \frac{K_R \cdot T}{d} \text{ [N]}$$

dove:

T = Momento torcente [Nm]
d = Diametro pignone o puleggia [mm]

K_R = 2000 per pignone per catena
= 2500 per ruote dentate
= 3000 per puleggia con cinghie a V

where:

T = torque [Nm]
d = pinion or pulley diameter [mm]

K_R = 2000 for chain pinion
= 2500 for wheel
= 3000 for V-belt pulley

dabei ist:

T = Drehmoment [Nm]
d = Kettenritzel- bzw. Riemscheiben durchmesser [mm]

K_R = 2000 bei Kettenritzel
= 2500 bei Zahnrad
= 3000 bei Riemscheibe mit Keilriemen

I valori dei carichi radiali e assiali generati dall'applicazione debbono essere sempre minori o uguali a quelli ammissibili indicati nelle tabelle.

The values of the radial and axial loads generated by the application must always be lower than or equal to the admissible values reported in the tables.

Die Werte der Radial- und Axialbelastungen, die durch die Anwendung hervorgerufen werden, dürfen nicht über den in den Tabellen angegebenen zulässigen Werten liegen.

$$F_R \geq Fr_{1-2}$$

Se il carico radiale sull'albero non è applicato a metà della sporgenza dell'albero, il valore del carico ammissibile deve essere valutato utilizzando la formula che si riferisce ad Fr_{1-2} , in cui i valori di a, b e Fr_{1-2} sono riportati nelle tabelle relative ai carichi radiali.

Nel caso di alberi bisporgenti il valore del carico applicabile a ciascuna estremità è uguale ai 2/3 del valore di tabella, purché i carichi applicati siano uguali di intensità e direzione ed agiscano nello stesso senso. Diversamente contattare il servizio tecnico.

Should the radial load affect the shaft not at the half-way point of its projection but at a different point, the value of the admissible load has to be calculated using the Fr_{1-2} formula: a, b and Fr_{1-2} values are reported in the radial load tables.

With regard to double-projecting shafts, the load applicable at each end is 2/3 of the value given in the table, on condition that the applied loads feature same intensity and direction and that they act in the same direction.

Otherwise please contact the technical department.

Falls die Radialbelastungen nicht in dem Mittelpunkt der herausragenden Welle sondern in einem anderen Punkt wirken, soll die zulässige Belastung mit der Formel bezüglich Fr_{1-2} kalkuliert werden: a, b und Fr_{1-2} Werte sind aus der Tabelle der Radialbelastungen zu entnehmen.

Bei doppelseitigen Abtriebswellen ist die Belastung, die an jedem Ende anwendbar ist, 2/3 des in der Tabelle angegebenen Wertes unter der Bedingung, dass die Belastungen die selbe Stärke und Richtung aufweisen und dass sie in der selben Richtung wirken. Andernfalls muß mit dem technischen Büro Rücksprache gehalten werden.

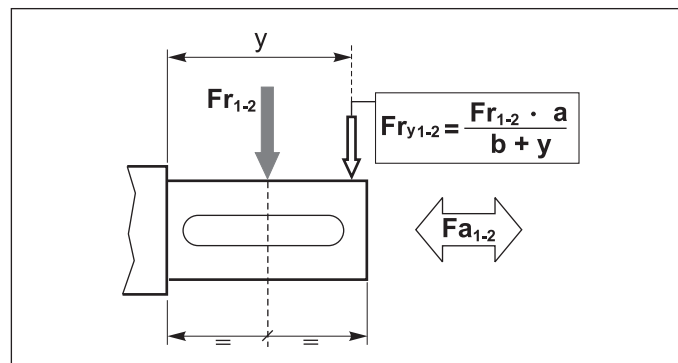

I carichi radiali indicati nelle tabelle si intendono applicati a metà della sporgenza dell'albero e sono riferiti ai riduttori operanti con fattore di servizio 1.

The radial loads indicated in the chart are considered to be applied at the half-way point of the shaft projection, and refer to gear units operating with service factor 1.

Die Radialbelastungen, die in den Tabellen angegeben werden, gelten für Ansatzpunkte in der Mitte des herausragenden Wellenteils und für Getriebe mit Betriebsfaktor 1.

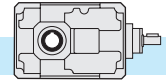

		T 56B		T 63B		T 75B				T 56C		T 63C		T 75C	
ALBERO ENTRATA / INPUT SHAFT / ANTRIEBSWELLE ($n_1 = 1400 \text{ min}^{-1}$)															
in	a = *	b = *	a = *	b = *	a = *	b = *	in	a = *	b = *	a = *	b = *	a = *	b = *	a = *	b = *
	Fr ₁	Fa ₁	Fr ₁	Fa ₁	Fr ₁	Fa ₁		Fr ₁	Fa ₁	Fr ₁	Fa ₁	Fr ₁	Fa ₁	Fr ₁	Fa ₁
Tutti A// Alle	*	*	*	*	*	*	Tutti A// Alle	*	*	*	*	*	*	*	*

* Consultare il ns. Servizio Tecnico.

* Contact Tramec Technical dept..

* Fragen sie Tramec technisches Büro.

		T 56B		T 63B		T 75B				T 56C		T 63C		T 75C	
ALBERO USCITA / OUTPUT SHAFT / ABTRIEBSWELLE ($n_1 = 1400 \text{ min}^{-1}$)															
	a = 106	b = 81	a = 121	b = 93.5	a = 106	b = 81	in	a = 106	b = 81	a = 121	b = 93.5	a = 121	b = 93.5		
	Fr ₂	Fa ₂	Fr ₂	Fa ₂	Fr ₂	Fa ₂		Fr ₂	Fa ₂	Fr ₂	Fa ₂	Fr ₂	Fa ₂	Fr ₂	Fa ₂
8	1300	260	1500	300	2500	500	40	2300	460	2500	500	—	—		
10	1300	260	1500	300	2500	500	50	2300	460	2500	500	3500	700		
12.5	1300	260	1500	300	2500	500	63	2300	460	2500	500	3500	700		
16	1800	360	2000	400	2500	500	80	2800	560	3000	600	3500	700		
20	1800	360	2000	400	3000	600	100	2800	560	3000	600	4000	800		
25	1800	360	2000	400	3000	600	125	2800	560	3000	600	4000	800		
31.5	1800	360	2000	400	3000	600	160	2800	560	3000	600	4000	800		
40	2300	460	2500	500	3500	700	200	3000	600	3500	700	4500	900		
50	2300	460	2500	500	3500	700	250	3000	600	3500	700	4500	900		
63	—	—	2500	500	—	—	315	—	—	3500	700	—	—		

		T 71B		T 90B		T 112B		T 140B		T 180B		T200B		T 225B	
ALBERO ENTRATA / INPUT SHAFT / ANTRIEBSWELLE ($n_1 = 1400 \text{ min}^{-1}$)															
in	a = 66.75	b = 51.75	a = 77	b = 57	a = 90	b = 70	a = 113	b = 83	a = 141.5	b = 101.5	a = 138.5	b = 98.5	a = 201	b = 146	
	Fr ₁	Fa ₁	Fr ₁	Fa ₁	Fr ₁	Fa ₁	Fr ₁	Fa ₁	Fr ₁	Fa ₁	Fr ₁	Fa ₁	Fr ₁	Fa ₁	
8-40	400	80	630	125	1000	200	1600	320	2500	500	2500	500	3150	630	
50÷ 80									2000	400	2000	400			
ALBERO USCITA / OUTPUT SHAFT / ABTRIEBSWELLE ($n_1 = 1400 \text{ min}^{-1}$)															
in	a = 114.5	b = 84.5	a = 131	b = 95	a = 161.5	b = 113.5	a = 192	b = 132	a = 236.5	b = 162	a = 276	b = 191	a = 325	b = 220	
	Fr ₂	Fa ₂	Fr ₂	Fa ₂	Fr ₂	Fa ₂	Fr ₂	Fa ₂	Fr ₂	Fa ₂	Fr ₂	Fa ₂	Fr ₂	Fa ₂	
≤ 8	—	—	4300	860	7000	1400	11000	2200	—	—	25000	5000	36000	7200	
10	3000	600	4750	950	7500	1500	11800	2360	19000	3800	26800	5360	38000	7600	
12.5	3150	630	5000	1000	8000	1600	12500	2500	20000	4000	28800	5760	40000	8000	
16	3350	670	5300	1060	8500	1700	13200	2640	21200	4240	30400	6080	42400	8480	
18	—	—	—	—	—	—	13600	2720	21800	4360	—	—	—	—	
20	3550	710	5600	1120	9000	1800	14000	2800	22400	4480	32200	6440	44800	8960	
25	3750	750	6000	1200	9500	1900	15000	3000	23600	4720	34000	6800	47200	9440	
31.5	4000	800	6300	1260	10000	2000	16000	3200	25000	5000	35800	7160	50000	10000	
35	—	—	—	—	—	—	16500	3300	25700	5140	—	—	—	—	
40	4250	850	6700	1340	10600	2120	17000	3400	26500	5300	37600	7520	53000	10600	
50÷ 80	4500	900	7100	1420	11200	2240	18000	3600	28000	5600	38000	7600	—	—	

		T 80C		T 100C		T 125C		T 160C		T180C		T 200C	
ALBERO ENTRATA / INPUT SHAFT / ANTRIEBSWELLE ($n_1 = 1400 \text{ min}^{-1}$)													
in	a = 66.75	b = 51.75	a = 77	b = 57	a = 90	b = 70	a = 113	b = 83	a = 113	b = 83	a = 141.5	b = 101.5	
	Fr ₁	Fa ₁	Fr ₁	Fa ₁	Fr ₁	Fa ₁	Fr ₁	Fa ₁	Fr ₁	Fa ₁	Fr ₁	Fa ₁	
Tutti A// Alle	400	80	630	125	1000	200	1600	320	2000	400	2500	500	
ALBERO USCITA / OUTPUT SHAFT / ABTRIEBSWELLE ($n_1 = 1400 \text{ min}^{-1}$)													
in	a = 131	b = 95	a = 161.5	b = 113.5	a = 192	b = 132	a = 236.5	b = 162	a = 276	b = 191	a = 325	b = 220	
	Fr ₂	Fa ₂	Fr ₂	Fa ₂	Fr ₂	Fa ₂	Fr ₂	Fa ₂	Fr ₂	Fa ₂	Fr ₂	Fa ₂	
Tutti A// Alle	8000	1600	12500	2500	20000	4000	32000	6400	43000	8600	53000	10600	

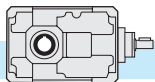

TA/TF 56B - TA/TF 63B - TA/TF 75B

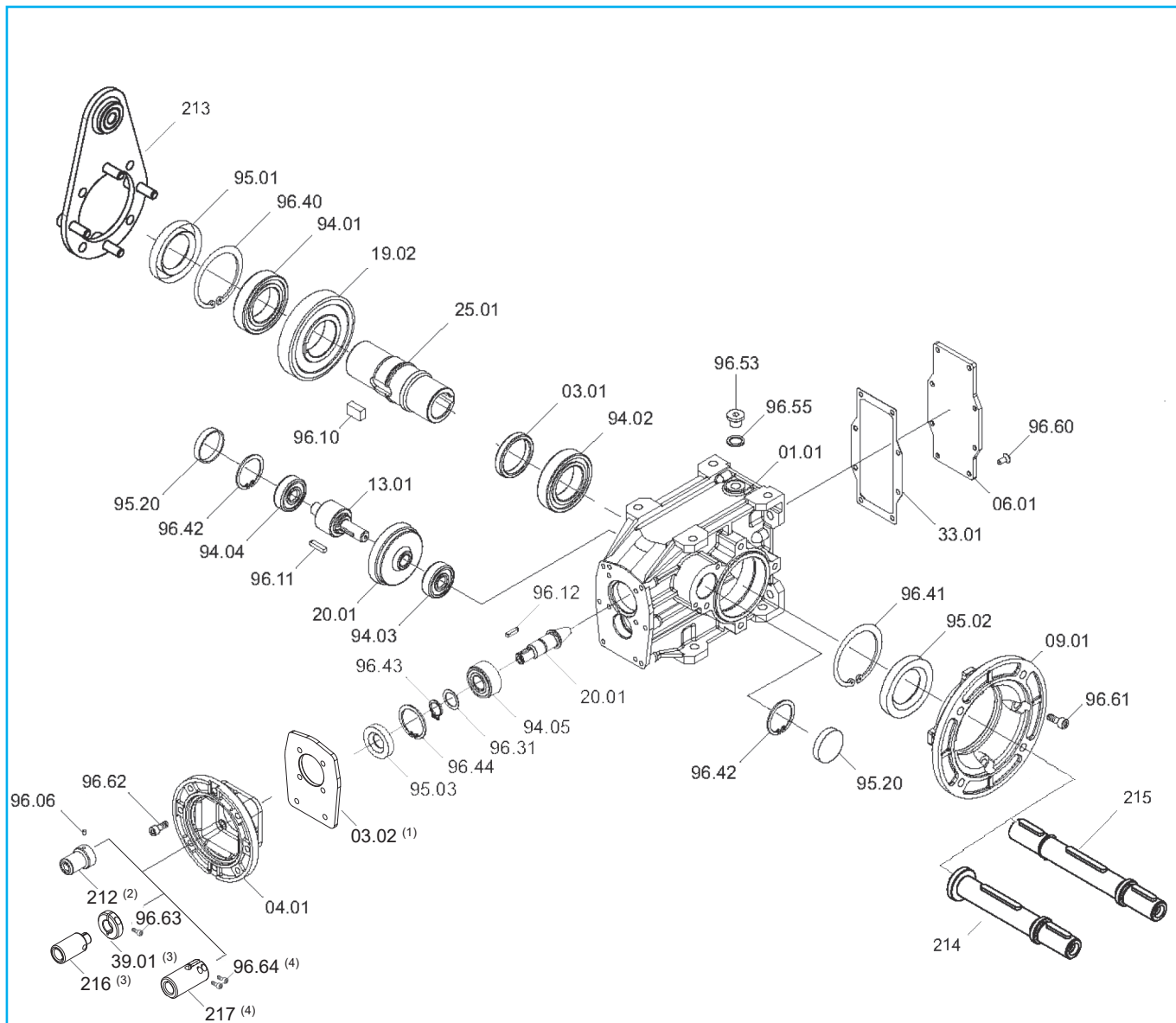

T	Cuscinetti/ Bearings / Lager					Anelli di tenuta / Oilseals / Öldichtungen			Cappellotto / Closed oil seal / Geschlossene Öldichtung
	94.01	94.02	94.03	94.04	94.05	95.01	95.02	95.03	95.20
56B	6007 35/62/14	6007 35/62/14	6201 12/32/10	6201 12/32/10	3201 12/32/15.9	35/62/7	35/62/7	12/32/7	ø 32x7
63B	6008 40/68/15	6008 40/68/15	6301 12/37/12	6301 12/37/12	3202 15/35/15.9	40/68/10	40/68/10	15/35/7	ø 37x7
75B	6010 50/80/16	6010 50/80/16	6203 17/40/12	6203 17/40/12	3202 15/35/15.9	50/80/8	50/80/8	15/35/7	ø 47x7

(1) Solo per TF75B PAM 71, 80, 90 / Only for TF75B PAM 71, 80, 90 / Nur für T75B PAM 71, 80, 90.

(2) Solo per TF56B e TF63B PAM 56, 63 / Only for TF56B and TF63B PAM 56, 63 / Nur für TF56B und TF63B PAM 56, 63.

(3) Solo per TF56B e TF63B PAM 71, 80, 90 / Only for TF56B and TF63B PAM 71, 80, 90 / Nur für TF56B und TF63B PAM 71, 80, 90.

(4) Solo per TF75B tutti i PAM / Only for TF75B all PAM / Nur für TF75B alle PAM.

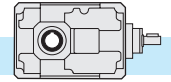

TA/TF 56C - TA/TF 63C - TA/TF 75 C

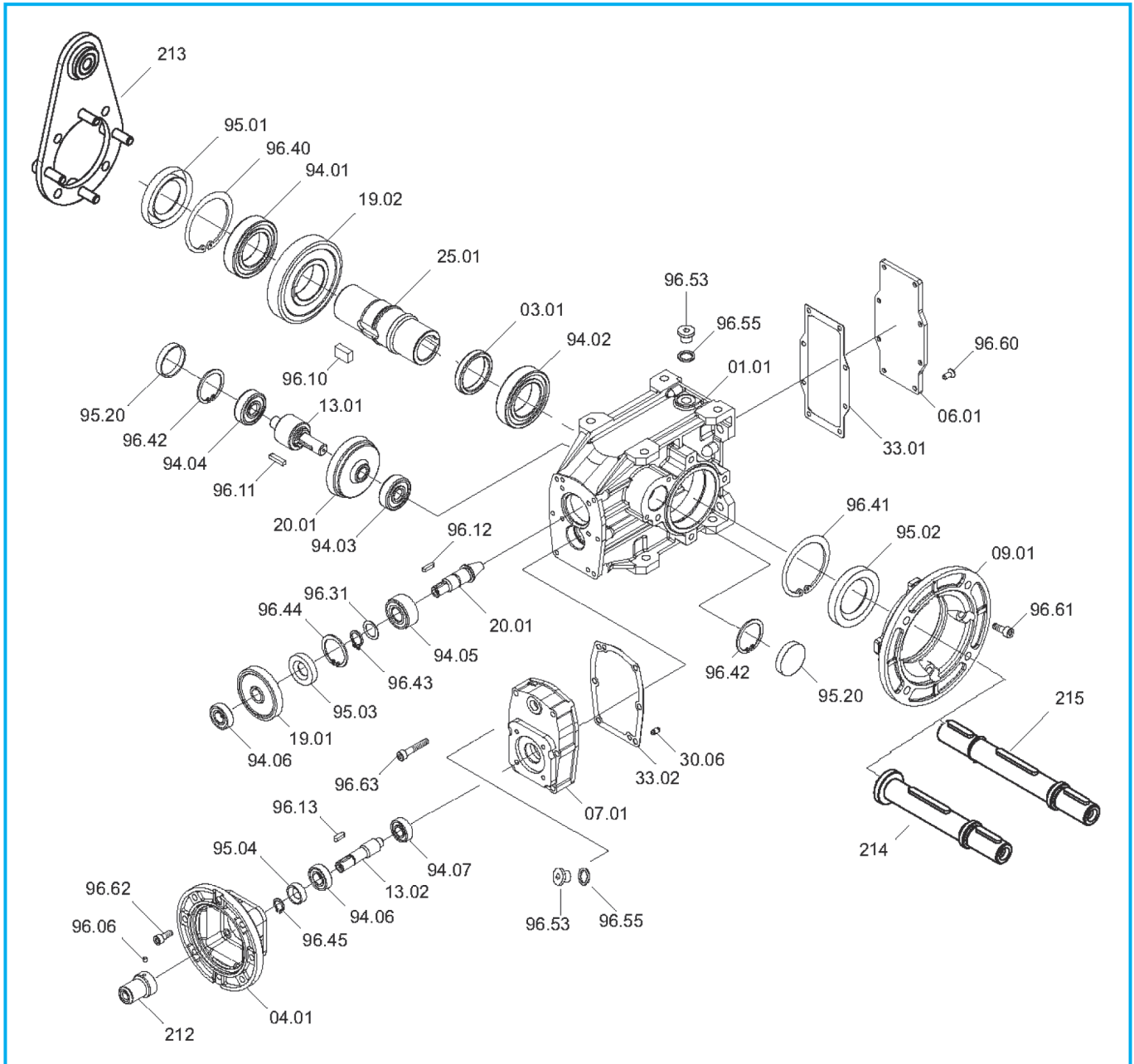

T	Cuscinetti/ Bearings / Lager								Anelli di tenuta / Oilseals / Öldichtungen				Cappellotto / Closed oil seal / Geschlossene Öldichtung
	94.01	94.02	94.03	94.04	94.05	94.06	94.07	94.08	95.01	95.02	95.03	95.04	95.20
56C	6007 35/62/14	6007 35/62/14	6201 12/32/10	6201 12/32/10	3201 12/32/15.9	6001 12/28/8	6000 10/26/8	6001 12/28/8	35/62/7	35/62/7	12/32/7	12/22/7	ø 32x7
63C	6008 40/68/15	6008 40/68/15	6301 12/37/12	6301 12/37/12	3202 15/35/15.9	6001 12/28/8	6000 10/26/8	6001 12/28/8	40/68/10	40/68/10	15/35/7	12/22/7	ø 37x7
75C	6010 50/80/16	6010 50/80/16	6203 17/40/12	6203 17/40/12	3202 15/35/15.9	6002 16/32/9	6000 10/26/8	6001 12/28/8	50/80/8	50/80/8	15/35/7	12/22/7	ø 47x7

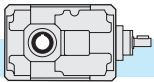

2.15 Lista parti di ricambio

2.15 Spare parts list

2.15 Ersatzteilliste

TA..B - TC..B - TF..B

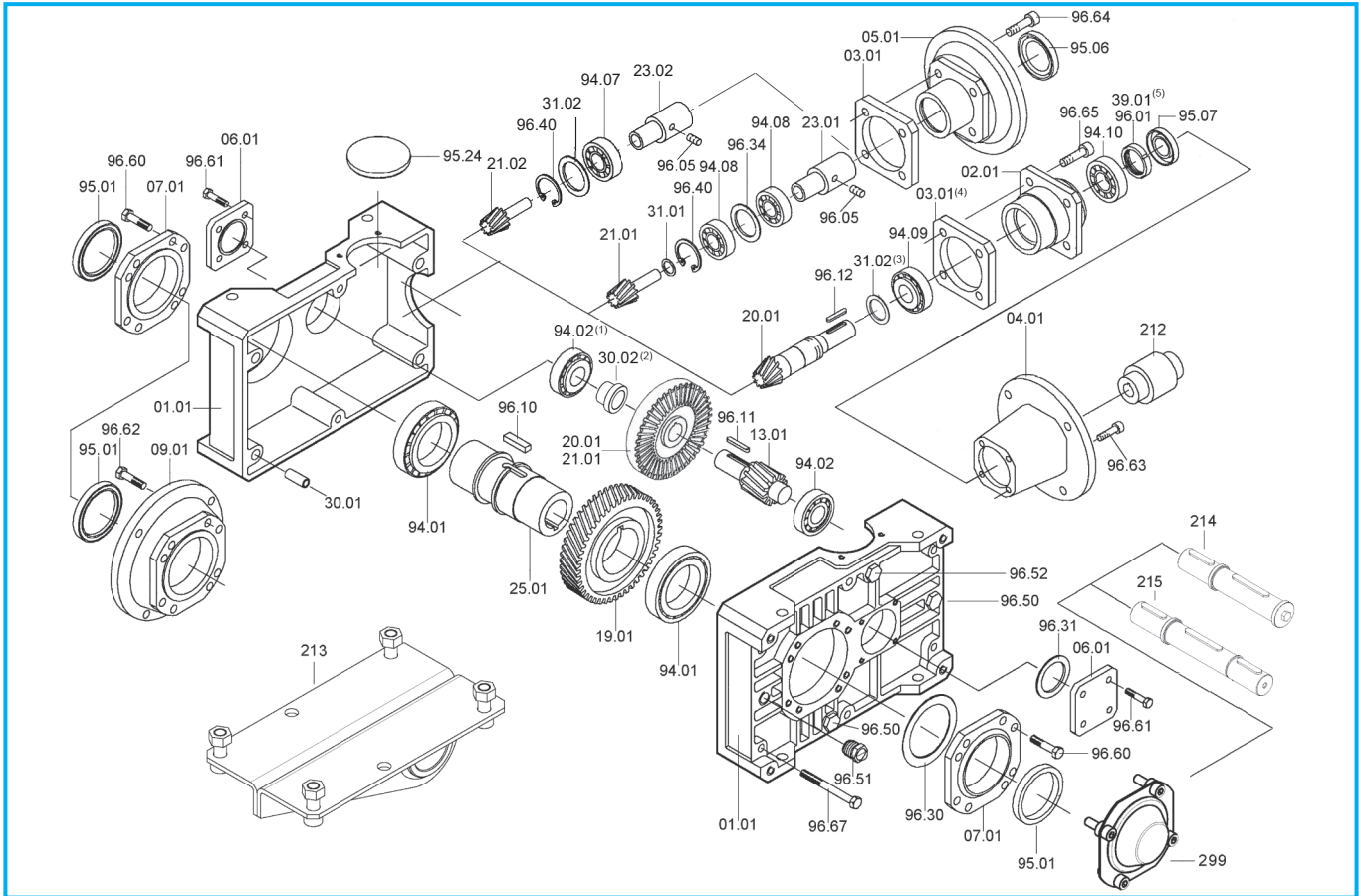

T	Cuscinetti/ Bearings / Lager					Anelli di tenuta / Oilseals / Öldichtungen											
	TA - TC - TF		TC		TA - TF		TA - TC - TF		TC		TA - TF						
	94.01	94.02	94.07	94.08	94.09	94.10	95.01	IEC	95.06	95.07							
71B	32008 40/68/19	30302 15/42/14.25	3203 17/40/17.5 (i= 50, 63, 80)	7203 17/40/12	30203 17/40/13.25	94.09	94.10	40/56/8	63	25/52/7	15/40/10						
									71	30/52/7							
									80	35/52/7							
									90	37/52/8							
90B	32010 50/80/20	30204 20/47/15.25	3205 25/52/20.6 (i= 50, 63, 80)	7205 25/52/15	32005 25/47/15	94.09	94.10	50/65/8	71 - 80	35/62/7	20/47/7						
									90	40/62/7							
									100 - 112	45/62/8							
									80 - 90	40/72/7							
112B	32012 60/95/23	30305 25/62/18.25	3206 30/62/23.8 (i= 50, 63, 80)	7206 30/62/16	32006 30/55/17	94.09	94.10	60/80/10	100 - 112	45/72/8	25/58/10						
									132	55/72/10							
									80 - 90	45/80/10							
									100 - 112	45/80/10							
140B	32015 75/115/25	32206B 30/62/21.25	3207 35/72/27 (i= 50, 63, 80)	7207 35/72/17	32007 35/62/18	94.09	94.10	75/95/10	132	55/80/10	30/62/7						
									160	60/80/8							
									180	65/80/8							
									100 - 112	55/100/13							
180B	32019 95/145/32	31307 35/80/22.75	—	7209 45/85/19	33109 45/80/26	94.09	94.10	95/125/12	132 - 160	60/100/10	40/80/10						
		32208 ⁽¹⁾ 40/80/24.75							180	65/100/10							
	32024 120/180/38	31309 45/100/27.25							—	7209 45/85/19		33109 45/80/26	94.09	94.10	120/160/15	200	75/100/10
																100 - 112	55/100/13
200B	32024 120/180/38	31309 45/100/27.25	—	7209 45/85/19	33109 45/80/26	94.09	94.10	120/160/15	132 - 160	60/100/10	40/80/10						
									180	65/100/10							
									200	75/100/10							
									100 - 112	55/100/13							
225B	32026 130/200/45	31310 50/110/29.25	—	—	33211 55/100/35	94.09	94.10	130/160/12	—	—	75/100/10						
									—	—							

(1) Presente solo nella versione con antiretro / Only on version with back stop device / Nur für die Version mit Rücklaufsperre

(2) Solo per T200B / Only for T200B / Nur für T200B

(3) Solo per T225B i=16 - 40 (no per i = 8 - 12.5) / Only for T225B i= 16- 40 (not for i = 8 - 12.5) / Nur für T225B i= 16- 40 (Nicht für i = 8 - 12.5)

(4) Non presente nel T225B / Not on T225B / Nicht vorhanden für T225B

(5) Solo per T225B / Only for T225B / Nur für T225B

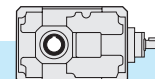

2.15 Lista parti di ricambio

2.15 Spare parts list

2.15 Ersatzteilliste

TA..C - TC..C - TF..C

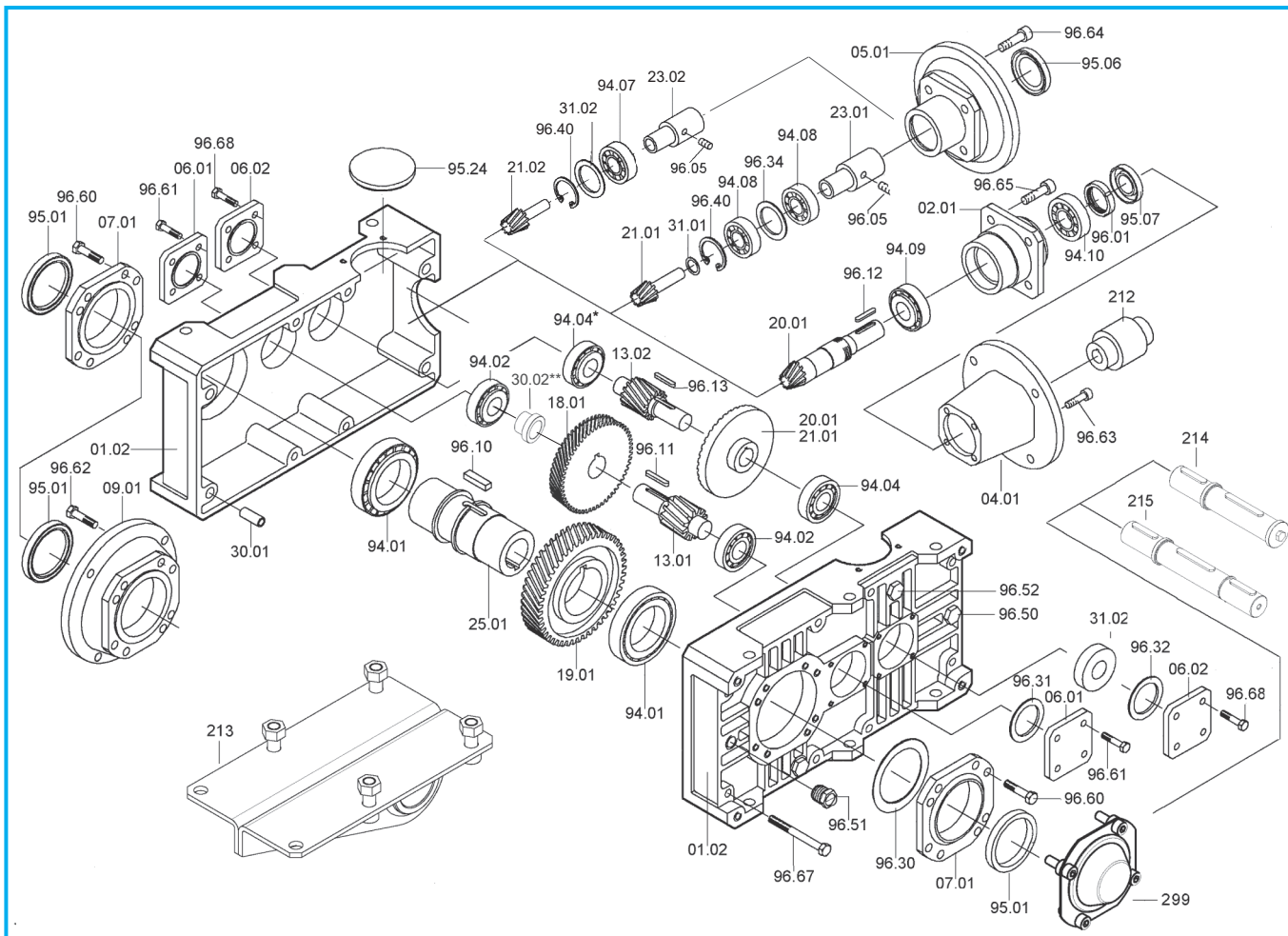

T	Cuscinetti / Bearings / Lager							Anelli di tenuta / Oilseals / Öldichtungen			
	TA - TC - TF			TC	TA - TF	TA - TC - TF	TC	TA - TF			
	94.01	94.02	94.04	94.07	94.08	94.09	94.10	95.01	IEC	95.06	95.07
80C	32010 50/80/20	30204 20/47/15.25	30302 15/42/14.25	3203 17/40/17.5	7203 17/40/12	30203 17/40/13.25	50/65/8	50/65/8	63	25/52/7	15/40/10
				(i= 250, 315, 400, 500, 630)					71	30/52/7	
									80	35/52/7	
									90	37/52/8	
100C	32012 60/95/23	30305 25/62/18.25	30204 20/47/15.25	3205 25/52/20.6	7205 25/52/15	32005 25/47/15	60/80/10	60/80/10	71 - 80	35/62/7	20/47/7
				(i= 250, 315, 400, 500, 630)					90	40/62/7	
									100 - 112	45/62/8	
125C	32015 75/115/25	32206 30/62/21.25	30305 25/62/18.25	3206 30/62/23.8	7206 30/62/16	32006 30/55/17	75/95/10	75/95/10	80 - 90	40/72/7	25/58/10
				(i= 250, 315, 400, 500, 630)					100 - 112	45/72/8	
									132	55/72/10	
160C	32019 95/145/32	32207 35/72/24.25	32206 30/62/21.25	3207 35/72/27	7207 35/72/17	32007 35/62/18	95/125/12	95/125/12	80 - 90	45/80/10	30/62/7
				(i= 250, 315, 400, 500, 630)					100 - 112	45/80/10	
									132	55/80/10	
									160	60/80/8	
180C	32024 120/180/38	31309 45/100/27.25	32206B 30/62/21.25	3207 35/72/27	7207 35/72/17	32007 35/62/18	120/160/15	120/160/15	180	65/80/8	30/62/7
				(i= 250, 315, 400)					80 - 90	45/80/10	
									100 - 112	45/80/10	
									132	55/80/10	
200C	32026 130/200/45	31310 50/110/29.25	30307 35/80/22.75	—	7209 45/85/38	33109 45/80/26	130/160/12	130/160/12	100 - 112	55/100/13	40/80/10
			* 32208 40/80/24.75						132 - 160	60/100/10	
									180	65/100/10	
									200	75/100/10	

* Presente solo nella versione con antiretro / Only on version with back stop device / Nur für die Version mit Rücklaufperre

** Solo per T180C / Only for T180C / Nur für T180C

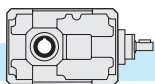

TA..B - TC..B - TF..B - TA..C - TC..C - TF..C

Dispositivo antiritorno - Backstop device - Rücklaufperre

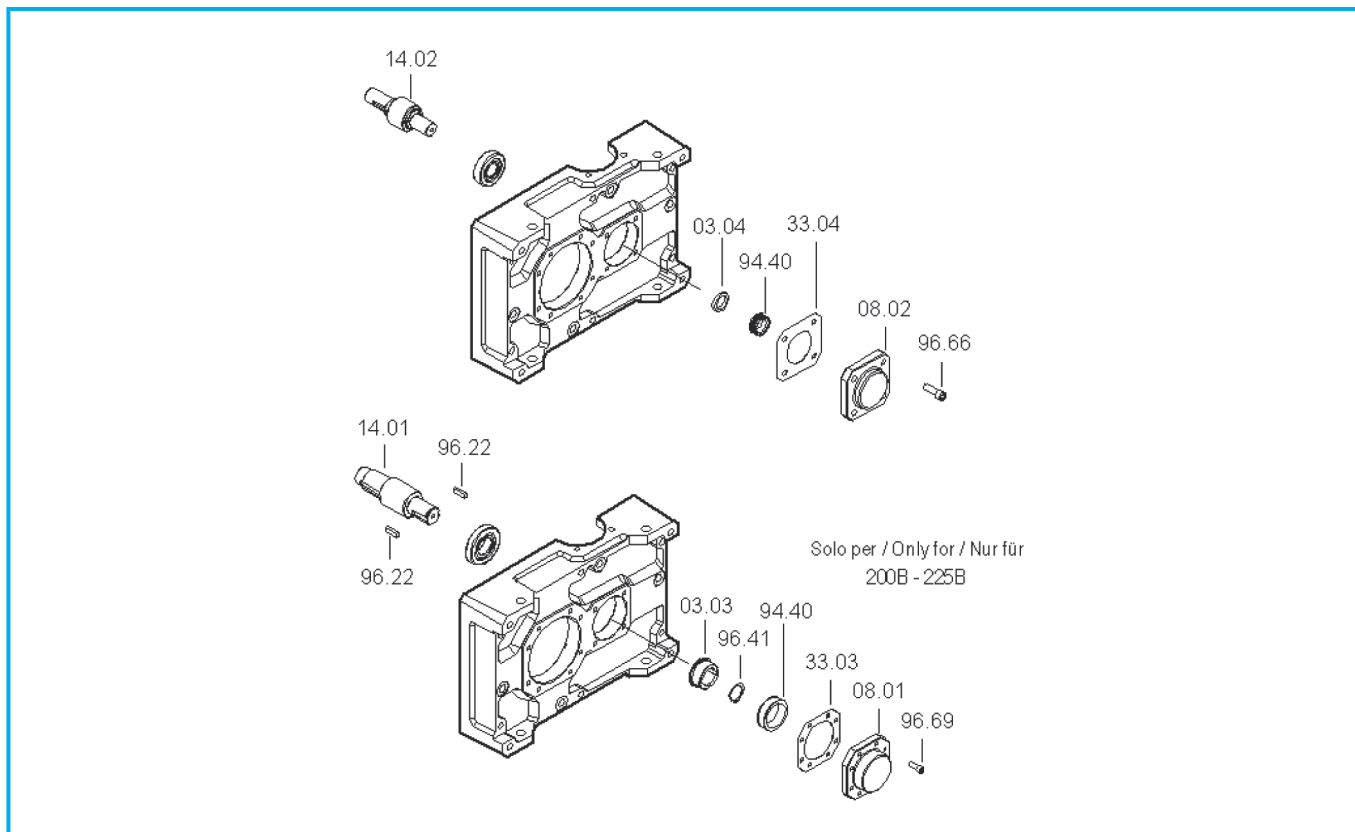

T...B	Ruota libera / Free wheel / Freilaufgrad 94.40
71	FE 423 Z
90	FE 428 Z
112	BF 50 Z 16
140	BF 70 Z 21
180	FE 8040 Z 19
200	FE 8054 Z 25
225	FE 8072 Z 25

T...C	Ruota libera / Free wheel / Freilaufgrad 94.40
80	FE 423 Z
100	FE 428 Z
125	BF 50 Z 16
160	BF 70 Z 21
180	BF 70 Z 21
200	FE 8040 Z 19

In fase di ordine delle parti di ricambio, specificare sempre n° particolare (vedi disegno esploso), data (1), n° codice (2) e n° variante (3). (Vedi targhetta).

CODICE: distinta base
CODE: base list
ART.-Nr.: Basisstückliste

TIPO: descrizione
TYPE: description
TYP: Bezeichnung

When ordering please specify the spare part number (see exploded view) as well as the date (1), the article number (2) and the variant number (3) (see plate)

Bei der Bestellung von Ersatzteilen sind Ersatzteilnummer (s. Explosionszeichnung), Datum (1), Artikelnummer (2) und Variantennummer (3) anzugeben. (s. Schild)

VARIANTE: codice alfanumerico
MODEL: alphanumeric code
VARIANTE: alphanumerische Nummer

RAP: rapporto di riduzione
RATIO: reduction ratio
ÜBERS: Untersetzungsverhältnis

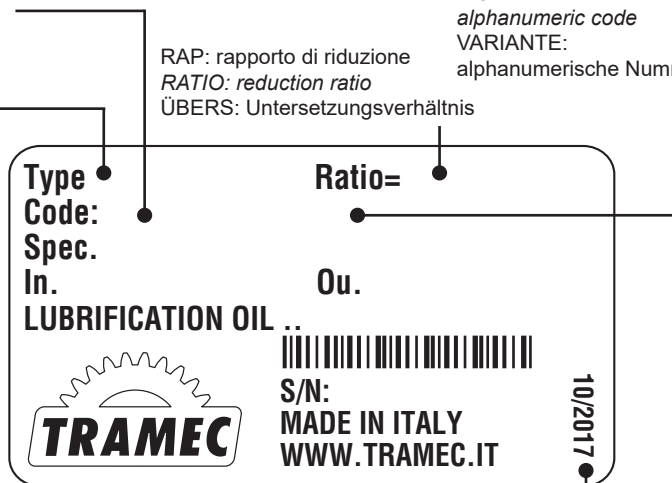

DATA: mese/anno
DATE: month/year
DATUM: Monat/Jahr