

1.0	GENERALITA'	GENERAL INFORMATION	ALLGEMEINES	2
1.1	Unità di misura	<i>Measurement units</i>	Maßeinheiten	3
1.2	Potenza	<i>Power</i>	Leistung	3
1.3	Rapporto di riduzione	<i>Reduction Ratio</i>	Untersetzungsverhältnis	3
1.4	Momento torcente	<i>Torque</i>	Drehmoment	3
1.5	Fattore di servizio	<i>Service factor</i>	Betriebsfaktor	4
1.6	Rendimento	<i>Efficiency</i>	Wirkungsgrad	5
1.7	Irreversibilità	<i>Irreversibility</i>	Selbsthemmung	6
1.8	Gioco angolare	<i>Backlash</i>	Winkelspiel	7
1.9	Senso di rotazione	<i>Direction of rotation</i>	Drehrichtung	7
1.10	Carichi radiali	<i>Radial load</i>	Radialbelastungen	8
1.11	Potenza termica	<i>Thermal power</i>	Thermische Leistung	10
1.12	Selezione	<i>Selection</i>	Wahl	11
1.13	Lubrificazione	<i>Lubrication</i>	Schmierung	12
1.14	Installazione	<i>Installation</i>	Installation	13
1.15	Manutenzione	<i>Maintenance</i>	Wartung	14
1.16	Verniciatura	<i>Painting</i>	Lackierung	14

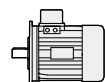
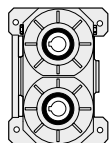
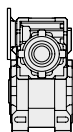
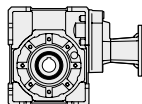
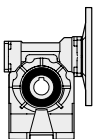
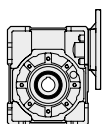

1.0 Generalità

TRAMEC si presenta oggi sul mercato con la nuova gamma di riduttori a vite senza fine con le seguenti serie:

1.0 General information

TRAMEC has introduced on the market a new range of worm gearboxes available as follows:

1.0 Allgemeines

TRAMEC hat auf dem Markt eine neue Auswahl an Schneckengetriebe aufgebracht:

Serie X

Riduttore a vite senza fine con corpo monolitico caratterizzato da una alta modularità di fissaggio grazie alla lavorazione in tolleranza di tutti i piani di appoggio.

Series X

Worm gearbox with monolithic body. Thanks to tolerance machining of all faces, the X series stands out for its high modularity of fastening options.

Serie X

Schneckengetriebe mit monolithischem Gehäuse. Dank der Bearbeitung mit Toleranz der Ablageflächen ist die X Serie durch die umfangreiche Modularität der Befestigungsmöglichkeiten gekennzeichnet.



Serie K

Riduttori a vite senza fine con forma rotonda che consente ingombri e pesi inferiori. Svariate possibilità di versioni sono facilmente ottenibili anche grazie ai suoi particolari di collegamento (piedi e flange) che sono separati.

Series K

Worm gearboxes with round shape are light in weight and require reduced space. The coupling parts (feet and flanges) are separated and therefore offer the possibility to obtain countless versions.

Serie K

Schneckengetriebe in rundem Gehäuse weisen ein geringes Gewicht auf und benötigen weniger Platz. Die Anbauteile (Fuesse und Flansche) sind modular aufgebaut, wodurch viele unterschiedliche Versionen möglich sind.

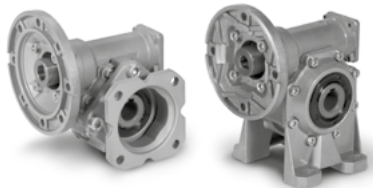

Serie H

Riduttore a vite senza fine con precoppia cilindrica con corpo monolitico. Si ottengono così rapporti più elevati conservando un buon rendimento.

Series H

Worm gearbox with cylindrical pre-stage module and single piece body. It offers higher ratios by maintaining a good efficiency.

Serie H

Schneckengetriebe mit zylindrischem Vorstufen-Modul und einteiligem Gehäuse. Es bietet höhere Untersetzungen bei gleichzeitig guter Effizienz.

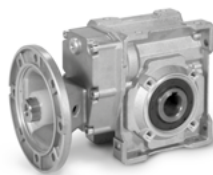

Serie KX - XX - KK

Riduttore combinato a doppia vite senza fine caratterizzato da elevate riduzioni di velocità.

KX - XX - KK Series

Worm gearbox with cylindrical pre-stage Combined worm gearbox with double worm shaft, it offers high speed reductions.

Serie KX - XX - KK

Kombinierte Doppelschneckengetriebe ermöglichen eine hohe Anzahl an Untersetzungsmöglichkeiten.

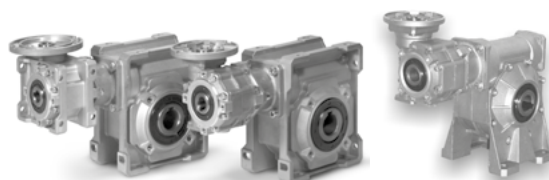

1.1 Unità di misura

1.1 Measurement units

1.1 Masseinheiten

Simbolo Symbol Symbol	Unità di misura Measurement unit Maßeinheit	Definizione	Definition	Beschreibung
FS'		Fattore di servizio riduttore	<i>Gearbox service factor</i>	Betriebsfaktor des Getriebes
FS		Fattore di servizio dell'applicazione	<i>Application service factor</i>	Betriebsfaktor der Anwendung
i_1		Rapporto di riduzione del 1° riduttore	<i>Ratio of 1st gearbox</i>	Untersetungsverhältnis des 1. Getriebes
i_2		Rapporto di riduzione del 2° riduttore	<i>Ratio of 2nd gearbox</i>	Untersetungsverhältnis des 2. Getriebes
i_n		Rapporto di riduzione	<i>Reduction ratio</i>	Untersetungsverhältnis
M_{2S}	[Nm]	Coppia di slittamento	<i>Slipping torque</i>	Rutschmoment
n_1	[min ⁻¹]	Giri in entrata	<i>Input speed</i>	Antriebsdrehzahl
n_2	[min ⁻¹]	Giri in uscita	<i>Output speed</i>	Abtriebsdrehzahl
P	[kW]	Potenza riduttore	<i>Gearbox capacity</i>	Getriebeleistung
P'	[kW]	Potenza richiesta in entrata	<i>Power required at input</i>	Erforderliche Leistung am Antrieb
P_1	[kW]	Potenza motoriduttore	<i>Gear motor power</i>	Getriebemotor Leistung
P_2	[kW]	Potenza in uscita	<i>Output power</i>	Abtriebsleistung
P_{1c}	[kW]	Potenza termica corretta	<i>Corrected thermal power</i>	verbesserte thermische Leistung
P_{10}	[kW]	Potenza termica nominale	<i>Thermal power</i>	Thermische Nennleistung
F_{r1}	[N]	Carico radiale albero entrata	<i>Input shaft radial load</i>	Radiallast an Antriebswelle
F_{r2}	[N]	Carico radiale albero uscita	<i>Output shaft radial load</i>	Radiallast an Abtriebswelle
F_{a1}	[N]	Carico assiale albero entrata	<i>Input shaft axial load</i>	Axiallast an Antriebswelle
F_{a2}	[N]	Carico assiale albero uscita	<i>Output shaft axial load</i>	Axiallast an Abtriebswelle
Rd		Rendimento dinamico	<i>Dynamic efficiency</i>	dynamischer Wirkungsgrad
Rs		Rendimento statico	<i>Static efficiency</i>	statischer Wirkungsgrad
Ta	[°C]	Temperatura ambiente	<i>Ambient temperature</i>	Umgebungstemperatur
T_{2M}	[Nm]	Momento torcente riduttore	<i>Gearbox torque</i>	Getriebe Drehmoment
T_2	[Nm]	Momento torcente motoriduttore	<i>Gear motor torque</i>	Getriebemotor Drehmoment
T_C	[Nm]	Momento torcente da utilizzare per la scelta del riduttore	<i>Torque to be used for the selection of the gearbox</i>	Drehmoment, das zur Wahl des Getriebe zu benutzen ist
T_2'	[Nm]	Momento torcente richiesto	<i>Required Torque</i>	benötigtes Drehmoment

1.2 Potenza

P = Potenza massima applicabile in entrata con vite ad albero maschio riferita alla velocità n_1 con un fattore di servizio FS = 1 e a un servizio continuo S1.

P_1 = Potenza motore consigliata riferita alla velocità n_1 con il fattore di servizio FS riportato in tabella a pag. 4 e a servizio continuo S1.

E' possibile determinare la potenza necessaria in entrata P' in base alla coppia T_2' richiesta all'applicazione secondo la seguente formula:

1.2 Power

P = max. power applicable at input with male worm shaft, referred to n_1 speed, service factor FS=1, on S1 continuous duty.

P_1 = recommended motor power, referred to n_1 speed, service factor FS as reported in the table on page 4, on S1 continuous duty.

The necessary input power with regard to T_2 torque required by the application, is to be calculated with the following formula:

$$P' = \frac{T_2' \cdot n_2}{9550 \cdot Rd} \quad [kW]$$

1.2 Leistung

P = am Antrieb max. anwendbare Leistung, mit Schneckenwellenzapfen bez. n_1 Antriebsdrehzahl, Betriebsfaktor FS=1 und S1 Dauerbetrieb.

P_1 = beratene Motorleistung bez. n_1 Drehzahl, FS Betriebsfaktor (wie es in der Tabelle auf Seite 4 angegeben wird) und S1 Dauerbetrieb.

Die am Antrieb erforderliche Leistung P' (auf Grund des von der Anwendung verlangten T_2 Drehmoments) kann wie folgt kalkuliert werden:

1.3 Rapporto di riduzione

i_n = È il rapporto di riduzione della velocità, definito come:

1.3 Reduction Ratio

i_n = speed reduction ratio, defined as follows:

$$i_n = \frac{n_1}{n_2}$$

1.3 Untersetungsverhältnis

i_n = Drehzahluntersetungsverhältnis, wird wie folgt definiert:

1.4 Momento torcente

T_{2M} = È la massima coppia trasmissibile in uscita del riduttore con carico uniforme riferito alla velocità n_1 con un fattore di servizio FS = 1 e a servizio continuo S1.

T_2 = È la coppia in uscita del motoriduttore riferita alla velocità n_1 alla potenza P_1 , con il fattore di servizio FS riportato in tabella e a servizio continuo S1.

1.4 Torque

T_{2M} = max. torque transmissible at gearbox output with uniform load, referred to n_1 speed, service factor FS = 1, on S1 continuous duty.

T_2 = output torque transmissible to the geared motor, referred to n_1 speed, P_1 power, FS service factor as reported in the table, on S1 continuous duty.

$$T_{2M} = \frac{9550 \cdot P_1 \cdot Rd}{n_2} \quad [Nm]$$

1.4 Drehmoment

T_{2M} = am Getriebeabtrieb max. übertragbaren Drehmoment, bei gleichmäßiger Last bez. n_1 Drehzahl, Betriebsfaktor FS = 1 und S1 Dauerbetrieb.

T_2 = übertragbares Abtriebsdrehmoment, bezogen auf die Antriebsdrehzahl n_1 , die Leistung P_1 und dem in der Tabelle angegebenen Betriebsfaktor FS bei Dauerbetrieb S1.

1.5 Fattore di servizio FS

È il valore che tiene in considerazione le varie condizioni di funzionamento:

- tipologia di applicazione ovvero natura del carico (A-B-C)
- durata di funzionamento (ore giornaliere h/gg)
- numero di avviamenti/ora

Il coefficiente così trovato (FS) dovrà essere uguale o inferiore al fattore di servizio del riduttore da adottare FS' dato dal rapporto tra la coppia T_{2M} indicata a catalogo e la coppia T_2 richiesta dall'applicazione.

1.5 FS Service factor

Value which takes the different operating conditions into consideration:

- type of application or type of load (A-B-C)
- length of operation (hours per day h/d)
- number of start-ups/hour

This coefficient (FS) will have to be equal or lower than the FS of selected gearbox FS' given by the ratio between T_{2M} torque mentioned in the catalogue and the T_2 torque required by the application.

1.5 Betriebsfaktor FS

Wert, der die verschiedenen Betriebsbedingungen in Betracht zieht:

- Art der Anwendung oder Art der Last (A-B-C)
- Betriebsdauer (Stunden pro Tag)
- Zahl der Starten pro Stunde

Der so berechnete Koeffizient (FS) muss kleiner oder gleich dem Betriebsfaktor FS' des Getriebes sein, welcher sich aus dem Verhältnis zwischen dem im Katalog angegebenen maximalen Drehmoment T_{2M} und dem von der Anwendung benötigten Drehmoment T_2 ergibt.

$$FS' = \frac{T_{2M}}{T_2} > FS$$

I valori di FS indicati in tabella sono relativi all'azionamento del motore elettrico; se utilizzato un motore a scoppio, si dovrà tenere conto di un fattore di moltiplicazione 1.3 se a più cilindri e 1.5 se monocilindrico. Se il motore elettrico applicato è autofrenante occorre considerare un numero di avviamenti doppio di quello effettivamente richiesto.

FS values reported in the table refer to the electric motor operation; should a combustion motor be used, consider a multiplication factor of 1.3 for a multicylinder motor, of 1.5 for a single-cylinder one. If an electric brake motor is used, consider a number of start-ups which is twice as much the number actually required.

Die in der Tabelle angegebenen FS Werte beziehen sich auf Anwendung eines Elektromotors. Falls einen Verbrennungsmotor verwendet wird, dann soll einen Multiplikationsfaktor von 1.3 für Mehrzylindermotor oder von 1.5 für Einzylindermotor in Betracht gezogen werden. Falls es sich um einen Elektro-Bremsmotor handelt, dann ist die Zahl der Starten doppelt zu zählen.

Classe di carico Load class Lastklasse	h/gg h/d St./Tag	N. AVVIAMENTI/ORA / N. START-UP/HOUR / ANZAHL DER STARTVORGÄNGE PRO STUNDE								
		2	4	8	16	32	63	125	250	500
A	4	0.8	0.8	0.9	0.9	1.0	1.1	1.1	1.2	1.2
	8	1.0	1.0	1.1	1.1	1.3	1.3	1.3	1.3	1.3
	16	1.3	1.3	1.3	1.3	1.5	1.5	1.5	1.5	1.5
	24	1.5	1.5	1.5	1.5	1.8	1.8	1.8	1.8	1.8
	APPLICAZIONI / APPLICATIONS / ANWENDUNGEN									
Agitatori per liquidi puri Alimentatori per fornaci Alimentatori a disco Filtri di lavaggio con aria Generatori Pompe centrifughe Trasportatori con carico uniforme			Pure liquid agitators Furnace feeders Disc feeders Air laundry filters Generators Centrifugal pumps Uniform load conveyors			Rührwerke für reine Flüssigkeiten Beschickungsvorrichtungen für Brennöfen Telleraufgeber Spülluftfilter Generatoren Kreiselpumpen Förderer mit gleichmäßig verteilter Last				
Carico uniforme Uniform load Gleichmäßig verteilte Last										
B	4	1.0	1.0	1.0	1.0	1.3	1.3	1.3	1.3	1.3
	8	1.3	1.3	1.3	1.3	1.5	1.5	1.5	1.5	1.5
	16	1.5	1.5	1.5	1.5	1.8	1.8	1.8	1.8	1.8
	24	1.8	1.8	1.8	1.8	2.2	2.2	2.2	2.2	2.2
	APPLICAZIONI / APPLICATIONS / ANWENDUNGEN									
Agitatori per liquidi e solidi Alimentatori a nastro Argani con medio servizio Filtri con pietre e ghiaia Viti per espulsione acqua Flocculatori Filtri a vuoto Elevatori a tazze Gru			Liquid and solid agitators Belt conveyors Medium service winches Stone and gravel filters Dewatering screws Flocculator Vacuum filters Bucket elevators Cranes			Rührwerke für Flüssigkeiten und Feststoffe Bandförderer Mittlere Winden Filter mit Steinen/Kies Abwasserschnecken Flockvorrichtungen Vakuumfilter Becherwerke Kräne				
Carico con urti moderati Moderate shock load Last mit mäßigen Stößen										
C	4	1.3	1.3	1.3	1.3	1.5	1.5	1.5	1.5	1.5
	8	1.5	1.5	1.5	1.5	1.8	1.8	1.8	1.8	1.8
	16	1.8	1.8	1.8	1.8	2.2	2.2	2.2	2.2	2.2
	24	2.2	2.2	2.2	2.2	2.5	2.5	2.5	2.5	2.5
	APPLICAZIONI / APPLICATIONS / ANWENDUNGEN									
Argani per servizio pesante Estrusori Calandre per gomma Pressa per mattoni Piallatrici Mulini a sfera			Heavy duty hoists Extruders Crusher rubber calenders Brick presses Planing machine Ball mills			Winden für schwere Lasten Extruder Gummikalander Ziegelpressen Hobelmaschinen Kugelmühle				
Carico con urti forti Heavy shock load Last mit starken Stößen										

1.6 Rendimento

Rd - È il rendimento dinamico, definito come rapporto tra la potenza in uscita P_2 e quella in entrata P_1 . Dipende principalmente dalla velocità di strisciamento, dal tipo di lubrificante e dall'angolo d'elica. I valori indicati nelle tabelle sono validi se si applica la corrispondente coppia in uscita. In fase di rodaggio, circa le prime 300 ore di funzionamento sotto carico, il valore deve essere considerato inferiore del 30% rispetto a quello indicato in tabella.

Rs - È il rendimento statico che si ha al momento dell'avviamento del riduttore e varia in base al rapporto di riduzione. Risulta importante, per una corretta valutazione del riduttore da impiegare, nelle applicazioni in cui non si raggiungono mai le condizioni di regime come nei funzionamenti intermittenti. Analogamente al caso dinamico, anche il rendimento statico durante il rodaggio risulta inferiore del 30% rispetto al valore indicato in tabella.

1.6 Efficiency

Rd - dynamic efficiency, defined as the ratio between P_2 output power and P_1 input power. It mainly depends on the slipping speed, the type of lubricant and the lead angle. The values reported in the table are valid when the corresponding output torque is applied. During the first 300 operating hours under load, the value to be considered is 30% lower than that reported in the table.

Rs - static efficiency at gearbox start-up; it changes depending on the reduction ratio. Rs value is important for selecting the right gearbox for applications where a steady state is never achieved, as for intermittent duty applications. Same as dynamic efficiency, static efficiency too during the running-in period will be 30% lower than the value reported in the table.

1.6 Wirkungsgrad

Rd - dynamischer Wirkungsgrad, ist das Verhältnis zwischen P_2 Abtriebsleistung und P_1 Antriebsleistung. Rd Wert wird durch Gleitgeschwindigkeit, Art des Schmiermittels und Steigungswinkel beeinflusst. Die Tabellen zeigen die Werte die gültig sind wenn das entsprechende Abtriebsdrehmoment gegeben ist. Während der Einlaufzeit in den ersten 300 Betriebsstunden unter Belastung, ist dieser Wert 30% niedriger als der in der Leistungstabelle angegebenen Wert.

Rs - statischer Wirkungsgrad beim Getriebebestart und in Abhängigkeit zur Unterersetzung. Der Wert Rs ist wichtig für die Auswahl des richtigen Getriebes für Anwendungen wo ein stetiger Betrieb nicht auftritt, wie bei Anwendungen mit Aussetzbetrieb. Der statischer Wirkungsgrad auch während der Einlaufzeit wird 30% niedriger als der in der Tabelle angegebenen Wert.

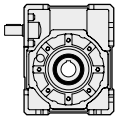

X - K	Rs											
	5	7.5	10	15	20	25	30	40	50	65	80	100
30	0.70	0.67	0.62	0.55	0.47	0.43	0.39	0.30	0.27	0.25	0.22	0.21
40	0.69	0.67	0.63	0.55	0.52	0.45	0.40	0.35	0.29	0.26	0.25	0.23
50	0.69	0.68	0.65	0.58	0.53	0.47	0.41	0.37	0.32	0.28	0.25	0.23
63	0.70	0.68	0.65	0.57	0.55	0.50	0.47	0.38	0.33	0.29	0.28	0.23
75	/	0.68	0.65	0.58	0.55	0.51	0.43	0.39	0.35	0.31	0.28	0.24
90	/	0.68	0.65	0.58	0.55	0.52	0.45	0.39	0.36	0.32	0.29	0.25
110	/	0.68	0.66	0.59	0.56	0.53	0.44	0.40	0.38	0.33	0.30	0.26
130	/	0.69	0.66	0.60	0.57	0.55	0.44	0.42	0.39	0.35	0.32	0.28

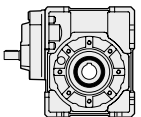

H	Rs										
	30	40	60	80	100	120	160	200	260	320	400
40	0.66	0.62	0.54	0.51	0.44	0.39	0.34	0.28	0.25	0.24	0.22
50	0.66	0.64	0.57	0.52	0.46	0.40	0.36	0.31	0.27	0.24	0.22
63	0.67	0.64	0.56	0.54	0.49	0.46	0.37	0.32	0.28	0.27	0.22
75	0.67	0.64	0.57	0.54	0.50	0.42	0.38	0.34	0.30	0.27	0.23
90	0.67	0.64	0.57	0.54	0.51	0.44	0.38	0.35	0.31	0.28	0.24
110	0.67	0.65	0.58	0.55	0.52	0.43	0.39	0.37	0.32	0.30	0.25
130	0.68	0.65	0.59	0.56	0.54	0.43	0.41	0.38	0.34	0.31	0.27

Stabilito il rapporto di riduzione necessario all'applicazione, dove è possibile, è consigliabile utilizzare i diversi tipi di riduttori che offrono, a parità di rapporto, un migliore rendimento dinamico.

Once the reduction ratio required by the application has been established, it is advisable to select a type of gearbox which, ratio being equal, offers better dynamic efficiency.

Nachdem das für die Anwendung erforderliche Untersetzungsverhältnis festgestellt worden ist, wählen Sie bei gleichem Untersetzungsverhältnis einen Getriebetyp, den einen besseren dynamischen Wirkungsgrad aufweist.

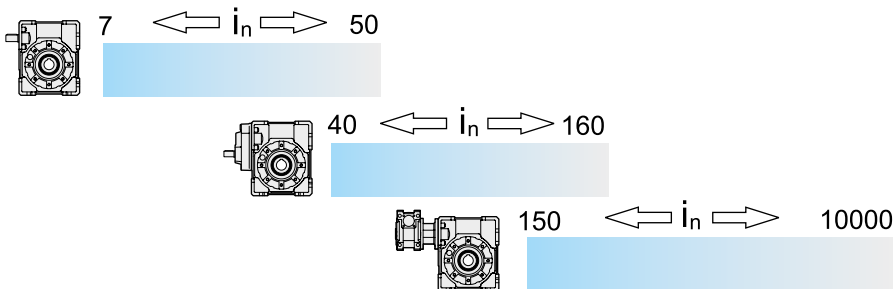

1.7 Irreversibilità

Nelle applicazioni dove è necessario evitare la trasmissione del moto retrogrado o sostenere il carico, in assenza di alimentazione elettrica, è consigliabile adottare freni esterni.

Nei riduttori a vite senza fine emerge questa caratteristica naturale, denominata grado di irreversibilità, che cresce con l'aumentare del rapporto di riduzione in quanto strettamente legata al relativo rendimento.

Per ottenere alti gradi di irreversibilità occorre quindi adottare i rapporti di riduzione più elevati, senza dimenticare che, il rendimento, tende a crescere durante le prime 500 ore di funzionamento per poi stabilizzarsi sui valori riportati a catalogo.

Irreversibilità statica

Condizione di impedimento alla rotazione comandata dall'albero lento senza escludere possibili ritorni lenti nel caso in cui il carico sia sottoposto a vibrazioni.

Rs < 0.45 si ha irreversibilità

Rs = 0.45 ÷ 0.55 irreversibilità incerta

Rs > 0.55 si ha reversibilità

Irreversibilità dinamica

Condizione di arresto e quindi di sostegno del carico nel momento in cui cessa l'azione di comando. La condizione è più difficile da ottenere in quanto viene influenzata dal rendimento dinamico, dalla velocità di rotazione, da eventuali vibrazioni che il carico può generare e dalla direzione del movimento rispetto al carico.

Quest'ultima condizione è molto evidente nei sollevamenti:

un carico in salita, cessando l'azione di comando, deve arrestarsi e quindi assumere velocità zero (rendimento statico) prima di invertire il moto e cadere per gravità.

Un carico in discesa tende invece a proseguire nel suo moto ostacolato, nella caduta, dal solo rendimento dinamico.

Rd < 0.45 si ha irreversibilità

Rd = 0.45 ÷ 0.55 irreversibilità incerta

Rd > 0.55 si ha reversibilità

1.7 Irreversibility

The use of external brakes is advised in case of applications where backwards motion must be hindered and the load must be held should the feed be cut off.

Some worm gearboxes feature natural irreversibility. The higher the ratio, the higher is the irreversibility, since it is strictly dependent on the relative efficiency.

In order to achieve high irreversibility it is therefore necessary to select higher efficiency reduction ratios not to forget that the efficiency is growing during the first 500 hours life until it stabilizes to the values mentioned in the catalogue.

Static irreversibility

Static irreversibility occurs when the rotation controlled by the output shaft is hindered; possible slow returns cannot be excluded should the load be subject to vibrations.

Rs < 0.45 provides irreversibility

Rs = 0.45 ÷ 0.55 irreversibility is uncertain

Rs > 0.55 reversibility is possible

Dynamic irreversibility

Dynamic irreversibility is characterized by stillstand and hold of the load when the drive stops.

It is more difficult to achieve this condition because it is influenced by dynamic efficiency, speed of rotation and possible vibrations generated by the motion direction with regard to the load.

This last condition is much more evident during the lifting: if the drive stops during the lifting of the load this has to come to a speed equals to zero (static irreversibility) before the reversal of motion rotation and its drop for gravity.

On the contrary the load during its descent gets its motion obstructed by its dynamic efficiency.

Rd < 0.45 provides irreversibility

Rd = 0.45 ÷ 0.55 irreversibility is uncertain

Rd > 0.55 reversibility is possible

1.7 Selbsthemmung

Aussenbremsen sind bei Anwendungen zu benutzen, bei denen Rückbewegung vermeiden werden muss oder die Last auch im Falle von Fehlen an Speisung gehalten werden muss.

Einige Schneckengetriebe sind selbsthemmend. Je höher die Untersetzung ist, desto höher ist die Selbsthemmung, da diese stark vom jeweiligen Wirkungsgrad abhängig ist. Um eine höhere Selbsthemmung zu erreichen, wählen Sie bitte höhere Untersetzungsverhältnisse.

Bitte beachten Sie, dass der Wirkungsgrad der Getriebe in den ersten 500 Betriebsstunden ansteigt und sich erst anschließend auf die im Katalog angegebenen Werte stabilisiert.

Statische Selbsthemmung

Statische Selbsthemmung liegt vor, wenn die von Abtriebswelle gesteuerten Drehung gehindert wird. Langsamer Rücklauf ist möglich, falls die Last Schwingungen ausgesetzt wird.

Rs < 0.45 es liegt Selbsthemmung vor

Rs = 0.45 ÷ 0.55 ungewisse Selbsthemmung

Rs > 0.55 es liegt Reversibilität vor

Dynamische Selbsthemmung

Stillstand und Stütze der Last beim Aussetzen der Steuerung.

Diese Bedingung ist schwieriger zu erreichen, da sie vom dynamischen Wirkungsgrad, der Drehzahl und von der Last verursachten möglichen Vibrationen abhängig ist

Dieser letzte Fall kommt bei Hubanwendungen stark zu tragen. Wenn der Antrieb während dem Hub stoppt, muss die Last eine Geschwindigkeit von annähernd null erreichen (statische Irreversibilität), bevor die Rotation sich umkehrt und die Last durch die Gravitation nach unten fährt. Dem entgegengesetzt bekommt die Last durch die Abwärtsbewegung Ihre dynamische Effizienz.

Rd < 0.45 es liegt Selbsthemmung vor

Rd = 0.45 ÷ 0.55 ungewisse Selbsthemmung

Rd > 0.55 es liegt Reversibilität vor

1.8 Gioco angolare

1.8 Backlash

1.8 Winkelspiel

X - K

i _n	30		40		50		63		75		90		110		130	
	min	max	min	max	min	max	min	max	min	max	min	max	min	max	min	max
5	10'	16'	9'	13.5'	7.5'	10.5'	7'	10'	/	/	/	/	/	/	/	/
7.5	10'	16'	9'	13.5'	7.5'	10.5'	7'	10'	7'	10'	6.5'	9.5'	6'	8'	6'	8'
10	10'	16'	9'	13.5'	7'	10.5'	7'	10'	7'	10'	6.5'	9'	6'	8'	6'	8'
15	10'	16'	9'	13.5'	7.5'	10.5'	7'	10'	7'	10'	6.5'	9'	6'	8'	6'	8'
20	9'	14.5'	7.5'	12'	6.5'	9.5'	6.5'	8.5'	6.5'	8.5'	6'	8.5'	6'	7'	6'	8'
25	9'	14.5'	7.5'	12'	6'	9.5'	6'	8.5'	6'	8.5'	6'	8.5'	5.5'	7'	5'	7'
30	9'	14.5'	7.5'	12'	6'	8.5'	6'	8.5'	6'	8.5'	6'	8.5'	5.5'	7'	5'	7'
40	9'	14.5'	7.5'	12'	6'	9.5'	6'	8.5'	6'	8.5'	6'	8'	5.5'	7'	5'	7'
50	8.5'	14'	7.5'	12'	6'	9.5'	6'	8.5'	6'	8.5'	6'	8'	5.5'	7'	5'	7'
65	8.5'	14'	7.5'	12'	6'	9'	6'	8'	6'	8'	6'	8'	5.5'	7'	5'	7'
80	8'	13.5'	7'	11.5'	6'	9'	5.5'	7.5'	5.5'	7.5'	5.5'	7.5'	5.5'	7'	5'	7'
100	8'	13'	7'	11'	6'	9'	5.5'	7.5'	5.5'	7.5'	5.5'	7.5'	5.5'	7'	5'	7'

H

i _n	40		50		63		75		90		110		130	
	min	max	min	max	min	max	min	max	min	max	min	max	min	max
30	12'	16.5'	10'	13.5'	9'	12'	9'	12'	8.5'	11.5'	7'	9'	7'	9'
40	12'	16.5'	10'	13.5'	9'	12'	9'	12'	8.5'	11'	7'	9'	7'	9'
60	12'	16.5'	10.5'	13.5'	9'	12'	9'	12'	8.5'	11'	7'	9'	7'	9'
80	10.5'	15'	9.5'	12.5'	8.5'	10.5'	8.5'	10.5'	8.5'	10.5'	7'	8'	7'	8'
100	10.5'	15'	9'	12.5'	8'	10.5'	8'	10.5'	8'	10.5'	6.5'	8'	6.5'	8'
120	12'	16.5'	10'	14.5'	8'	11.5'	9.5'	12'	8.5'	11'	7.5'	9'	6.5'	8'
160	10.5'	15'	9'	12.5'	8'	10.5'	8'	10.5'	8'	10.5'	6.5'	8'	6.5'	8'
200	10.5'	15'	9'	12.5'	8'	10.5'	8'	10.5'	8'	10'	6.5'	8'	6.5'	8'
260	10.5'	15'	9'	12.5'	8'	10.5'	8'	10.5'	8'	10'	6.5'	8'	6.5'	8'
320	10'	14.5'	9'	12'	7.5'	9.5'	7.5'	9.5'	7.5'	9.5'	6.5'	8'	6.5'	8'
400	10'	14'	9'	12'	7.5'	9.5'	7.5'	9.5'	7.5'	9.5'	6.5'	8'	6.5'	8'

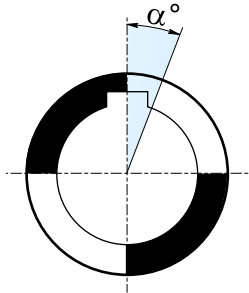

Misurato bloccando l'albero entrata, e ruotando l'albero uscita nelle due direzioni applicando la coppia strettamente necessaria a creare il contatto tra i denti degli ingranaggi, al massimo pari al 2% della coppia nominale (T_{2M}).

Angular backlash measured after having blocked the input shaft by rotating output shaft in both directions and applying the torque which is strictly necessary to create a contact between the teeth of the gears. The applied torque should be at most 2% of the max. torque (T_{2M}).

Nachdem die Antriebswelle blockiert worden ist, darf das Winkelspiel auf die Abtriebswelle bemessen werden. Dabei soll die Antriebswelle in beiden Richtungen gedreht werden und ein Drehmoment ausgeübt werden, das zur Entstehen eines Kontaktes zwischen den Zahnen genuegt. Das ausgeübte Drehmoment soll höchstens 2% des max. von Getrieben garantierten Drehmoment (T_{2M}) sein.

1.9 Senso di rotazione

1.9 Direction of rotation

1.9 Drehrichtung

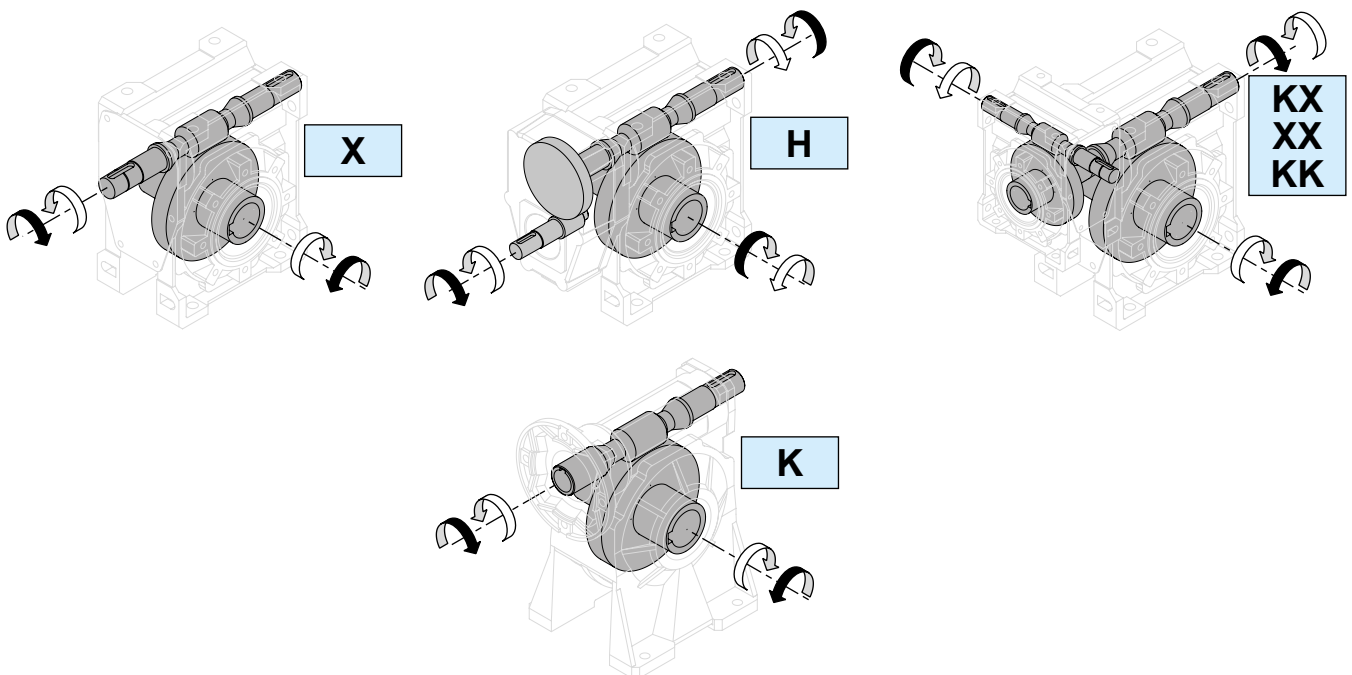

1.10 Carichi radiali

Ogni tipo di organo di trasmissione che viene collegato o sull'albero in entrata o in quello di uscita determina carichi radiali rispettivamente Fr_1 e Fr_2 .

I valori riportati in tabella in funzione delle varie velocità in entrata e in uscita sono da considerarsi applicabili come forza agente a metà della sporgenza; per un posizionamento a 1/3 della lunghezza occorre aumentare i valori di tabella del 25% mentre per un posizionamento a 2/3 della lunghezza occorre diminuire gli stessi valori del 25%.

I valori dei carichi assiali applicabili in entrata Fa_1 e in uscita Fa_2 sono indicati nelle tabelle.

Negli alberi bisporgenti, ogni estremità può sopportare un carico radiale pari ai 3/5 dei valori riportati in tabella purché agiscano nello stesso senso e siano di pari intensità

1.10 Radial load

Any transmission device coupled to either the input or to the output shaft generates radial loads, Fr_1 and Fr_2 respectively.

The load values reported in the table, depending on input and output speed, are to be considered as acting at the half-way point of the projection; if the load is applied at 1/3 of the projection, increase the values in the table by 25%; if the load is applied at 2/3, reduce the values by 25%.

Axial loads applicable at input Fa_1 and at output Fa_2 are reported in the tables.

With regard to double projecting shafts, each end can sustain a radial load which equals 3/5 of the values listed in the table, on condition that they act in the same direction and have the same intensity.

1.10 Radial Load

Antriebsorgane, die mit der Antriebs- oder Abtriebswelle verbunden werden, bewirken Radialbelastungen (Fr_1 und Fr_2 beziehungsweise).

Die in der Tabelle nach Antriebs- und Abtriebsdrehzahl angegebenen Werte beziehen sich auf Belastungen, die in der Mitte der herausragenden Welle wirken; falls die Belastungen auf 1/3 der Länge wirken, sollen die in der Tabelle angegebenen Werte um 25% erhöht werden; falls sie auf 2/3 der Länge wirken, sollen die Werte der Tabelle um 25% reduziert werden.

Die Werte der anwendbaren Axialbelastungen (Fa_1 am Antrieb und Fa_2 am Abtrieb) werden in den Tabellen angegeben. Bei doppelseitig herausragenden Wellen darf die Radialbelastung auf jedes Ende 3/5 der nachstehenden Werte betragen, unter die Bedingung dass Stärke und Richtung gleich sind.

Carichi radiali Fr_1 e assiali Fa_1 sull'albero entrata [N]

Fr_1 radial loads and Fa_1 axial loads on the input shaft [N]

Fr_1 Radialbelastungen und Fa_1 Axialbelastungen auf die Antriebswelle [N]

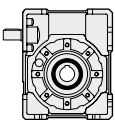
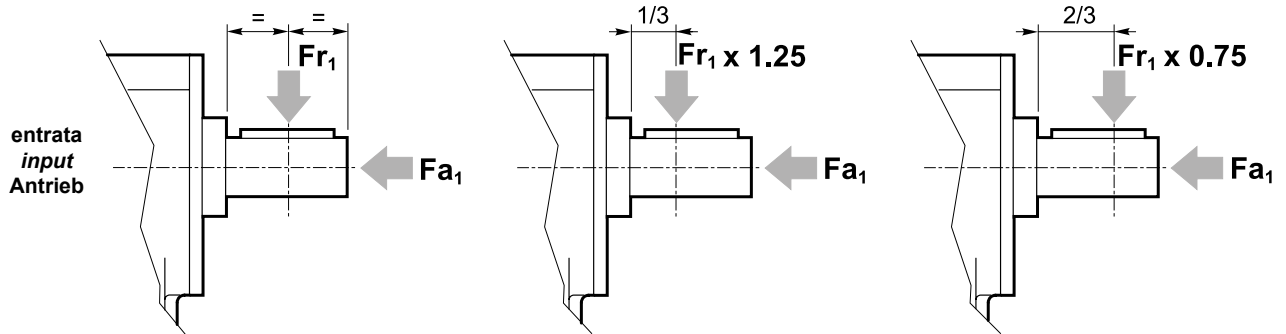

n_1 [min ⁻¹]	XA30		XA40		XA50		XA63		XA75		XA90		XA110		XA130	
	Fr_1	Fa_1	Fr_1	Fa_1	Fr_1	Fa_1	Fr_1	Fa_1	Fr_1	Fa_1	Fr_1	Fa_1	Fr_1	Fa_1	Fr_1	Fa_1
1400	100	20	220	44	400	80	480	96	750	150	850	170	1200	240	1500	300
			HA40		HA50		HA63		HA75		HA90		HA110		HA130	
1400			Fr_1	Fa_1	Fr_1	Fa_1	Fr_1	Fa_1	Fr_1	Fa_1	Fr_1	Fa_1	Fr_1	Fa_1	Fr_1	Fa_1
			150	30	250	50	320	64	570	114	570	114	800	160	1000	200
			XXA30/30 XXA30/40 XXA30/50 XXA30/63		XXA40/63 XXA40/75 XXA40/90		XXA50/75 XXA50/90 XXA50/110		XXA63/110		XXA63/130		-			
1400			Fr_1	Fa_1	Fr_1	Fa_1	Fr_1	Fa_1	Fr_1	Fa_1	Fr_1	Fa_1				
			100	20	220	44	400	80	480	96	480	96				

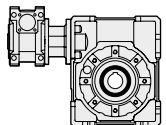

Carichi radiali Fr_2 e assiali Fa_2 sull'albero uscita [N]

Fr_2 radial loads and Fa_2 axial loads on the output shaft [N]

Fr_2 Radialbelastungen und Fa_2 Axialbelastungen auf die Abtriebswelle [N]

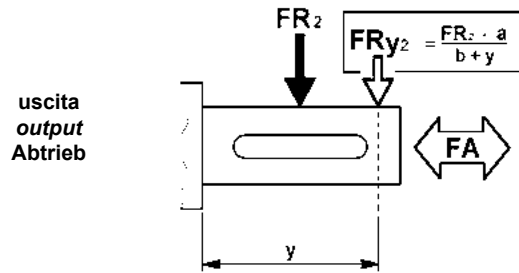

CUSCINETTI RADIALI A SFERE / RADIAL BALL BEARINGS / SCHRÄGKUGELLAGER																	
$n_1=1400$ rpm		30		40		50		63		75		90		110		130	
		30/30		30/40		30/50		30/63 40/63		40/75 50/75		40/90 50/90		50/110 63/110		63/130	
i_n	n_2 [rpm]	a = 66.5 b = 49		a = 83.5 b = 60.5		a = 102 b = 73.5		a = 122.5 b = 93.5		a = 134 b = 100		a = 163 b = 118		a = 179.5 b = 131.5		a = 190 b = 145	
		Fr_2	Fa_2	Fr_2	Fa_2	Fr_2	Fa_2	Fr_2	Fa_2	Fr_2	Fa_2	Fr_2	Fa_2	Fr_2	Fa_2	Fr_2	Fa_2
5	280	700	140	1400	280	1400	300	1800	360	/	/	/	/	/	/	/	/
7.5	187	750	150	1500	300	1650	330	2100	420	2500	500	2600	520	3500	700	5100	1020
10	140	800	160	1600	320	1800	360	2300	460	2800	560	3000	600	3800	760	5600	1120
15	93	850	170	1700	340	1950	390	2600	520	3000	600	3400	680	4200	840	6400	1280
20	70	900	180	1800	360	2200	440	2800	560	3300	660	3800	760	4600	920	7000	1400
25	56	950	190	1900	380	2400	480	3100	620	3700	740	4100	820	5100	1020	7600	1520
30	47	1000	200	2000	400	2600	520	3400	680	4000	800	4500	900	5600	1120	8050	1610
40	35	1050	210	2100	420	2850	570	3700	740	4400	880	4900	980	6100	1220	8800	1760
50	28	1100	220	2200	440	3100	620	4000	800	4850	970	5300	1060	6700	1340	9500	1900
60	23	1150	230	2400	480	3200	640	4200	840	5000	1000	5600	1120	7100	1420	9800	2000
63	22	1250	250	2500	500	3400	680	4450	890	5300	1060	5900	1180	7400	1480	10100	2020
80	17.5	1350	270	2700	540	3800	760	4900	980	5800	1160	6500	1300	8100	1620	11200	2240
100	14	1500	300	3000	600	4000	800	5400	1080	6500	1300	7000	1400	8500	1700	12050	2410
120	11.7	1520	304	3100	620	4100	820	5500	1100	6550	1310	7100	1420	8800	1760	12200	2500
150	9.3	1550	310	3150	630	4250	850	5600	1120	6600	1320	7300	1460	9100	1820	12500	2600
160	8.8	1570	314	3200	640	4300	860	5700	1140	6700	1340	7400	1480	9200	1840	12800	2650
≥ 200	≤ 7.0	1600	320	3300	660	4500	900	6000	1200	7100	1420	7900	1580	10000	2000	13000	2800

Versioni rinforzate

A richiesta vengono fornite versioni rinforzate con cuscinetti a rulli conici sulla corona in grado di sopportare carichi superiori rispetto a quelli ammessi nelle versioni normali con cuscinetti radiali a sfere.

Essendo tali valori calcolati in funzione della durata dei cuscinetti, occorre valutare attentamente il tipo di versione più idoneo in modo da evitare problemi di tipo strutturale. In particolare, il carico assiale deve agire in modo da comprimere la flangia uscita.

I carichi assiali e radiali riportati in tabella non possono agire contemporaneamente nei loro valori massimi.

Nel caso di eventuale concorrenza delle due forze, queste devono essere limitate in rapporto al tipo di carico prevalente:

1. condizione di prevalenza del carico radiale:

Fr_2 = come a tabella
 Fa_2 = $Fr_2 \cdot 0.37$

Reinforced versions

The versions reinforced with tapered roller bearings on the worm wheel are available on request. They can bear higher loads compared to standard versions with radial ball bearings.

These values are calculated in relation of the life of bearings therefore it is necessary to select the most suitable version in order to avoid any structural problem. In particular the axial load must compress the output flange.

The axial and radial loads shown in the table do not have to act simultaneously according to the max. values.

In case of concurrency of both forces these have to be reduced with regard to the prevailing type of load:

1. prevalence of radial load:

Fr_2 = as per table
 Fa_2 = $Fr_2 \cdot 0.37$

Versionen mit Kegelrollenlager

Auf Wunsch können Versionen mit Kegelrollenlager auf dem Schneckenrad geliefert werden. Sie erlauben höheren Lasten in Vergleich zu den Standardprodukten mit Schrägkugellagern.

Diese Werte sind entsprechend der Lebensdauer der Lager berechnet. Daher ist es erforderlich, die am besten passende Ausführung zu wählen, um Probleme zu vermeiden. Auf alle Fälle muss die Axialbelastung den Abtriebsflansch zusammendrücken.

Die in der Tabelle angegebenen Maximalwerte der Axial- und Radialbelastung sollten nicht gleichzeitig auftreten.

Falls Axial- und Radialbelastungen auftreten, sollte jene Belastungsrichtung zur Auswahl herangezogen werden, die vom Anteil überwiegt:

1. radialbelastungen überwiegen:

Fr_2 = siehe Tabelle
 Fa_2 = $Fr_2 \cdot 0.37$

2. condizione di prevalenza del carico assiale:

$$Fa_2' = Fa_2 \cdot 0.6$$

$$Fr_2' = Fa_2 \cdot 0.4$$

2. prevalence of axial load:

$$Fa_2' = Fa_2 \cdot 0.6$$

$$Fr_2' = Fa_2 \cdot 0.4$$

2. Axialbelastungen überwiegen

$$Fa_2' = Fa_2 \cdot 0.6$$

$$Fr_2' = Fa_2 \cdot 0.4$$

CUSCINETTI A RULLI CONICI / TAPERED ROLLER BEARINGS / KEGELROLLENLAGER																	
n ₁ =1400 rpm		30		40		50		63		75		90		110		130	
		30/30		30/40		30/50		30/63 40/63		40/75 50/75		40/90 50/90		50/110 63/110		63/130	
i _n	n ₂ [rpm]	a = 61.4 b = 43.9		a = 77 b = 54		a = 94.5 b = 66		a = 114.8 b = 85.8		a = 123.8 b = 89.8		a = 152.8 b = 107.8		a = 167.3 b = 119.3		a = 174.8 b = 129.8	
		Fr ₂	Fa ₂	Fr ₂	Fa ₂	Fr ₂	Fa ₂	Fr ₂	Fa ₂	Fr ₂	Fa ₂	Fr ₂	Fa ₂	Fr ₂	Fa ₂	Fr ₂	Fa ₂
5	280	800	1100	1800	2300	4000	5000	4000	5000	/	/	/	/	/	/	/	/
7.5	187	900	1200	1900	2400	4500	5500	4500	5500	5300	6500	6000	8000	8000	10500	9500	11000
10	140	1000	1300	2000	2500	5000	6000	5000	6000	5500	6700	7000	9200	8300	11000	10500	12500
15	93	1100	1400	2100	2600	5800	7000	5800	7000	5700	6900	7400	9800	8800	11500	11000	13000
20	70	1250	1650	2300	2800	6000	7200	6100	7300	6400	7600	7800	10300	9300	12000	15000	13500
25	56	1450	1900	2500	3000	6200	7500	6500	7700	7400	9400	8500	11000	9800	12500	12000	14000
30	47	1700	2200	2800	3300	6500	7800	6800	8000	8000	10000	9500	12000	10500	13200	12500	14000
40	35	1800	2300	3000	3500	6600	8000	7000	8200	8500	10500	10000	12500	11000	14000	14000	16000
50	28	1900	2400	3200	3700	6800	8200	7100	8400	9000	11000	10500	13000	12000	15000	14500	17000
60	23	1900	2400	3200	3700	6800	8200	7100	8400	9000	11000	10500	13000	12000	15000	15000	17000
63	22	1900	2400	3200	3700	6800	8200	7100	8400	9000	11000	10500	13000	12000	15000	15000	17000
80	17.5	1900	2400	3200	3700	6800	8200	7100	8400	9000	11000	10500	13000	12000	15000	15000	17000
100	14	1900	2400	3200	3700	6800	8200	7100	8400	9000	11000	10500	13000	12000	15000	15000	17000
120	11.7	1900	2400	3200	3700	6800	8200	7100	8400	9000	11000	10500	13000	12000	15000	15000	17000
150	9.3	1900	2400	3200	3700	6800	8200	7100	8400	9000	11000	10500	13000	12000	15000	15000	17000
160	8.8	1900	2400	3200	3700	6800	8200	7100	8400	9000	11000	10500	13000	12000	15000	15000	17000
≥ 200	≤ 7.0	1900	2400	3200	3700	6800	8200	7100	8400	9000	11000	10500	13000	12000	15000	15000	17000
Cuscinetto Bearing Lager		32005 25x47x15		32006 30x55x17		32008 40x68x19		32008 40x68x19		32010 50x80x20		32010 50x80x20		32012 60x95x23		32015 75x115x25	

1.11 Potenza termica

Nelle tabelle riportate nelle sezioni relative ad ogni tipologia di riduttore sono indicati i valori della potenza termica nominale P_{t0} [kW]. Tale valore rappresenta la potenza massima applicabile all'entrata del riduttore, in servizio continuo a temperatura massima ambiente di 30°C, così che la temperatura dell'olio non oltrepassi il valore di 95°C.

Il valore di P_{t0} non deve essere preso in considerazione se il funzionamento è continuo per un massimo di 1 - 2 ore seguito da pause di durata sufficiente (circa 2 ore) a ristabilire nel riduttore la temperatura ambiente.

I valori di P_{t0} devono essere corretti tramite i seguenti coefficienti, così da considerare le reali condizioni di funzionamento, ottenendo i valori di potenza termica corretta P_{tc}.

1.11 Thermal power

The sections dedicated to each type of gearbox contain tables reporting the values of P_{t0} rated thermal power (kW). Listed values represent the max. power applicable at gearbox input, on continuous duty and at an ambient temperature of max. 30°C, so that oil temperature does not exceed 95°C.

P_{t0} value is not to be taken into account if duty is continuous for max. 1 - 2 hours and followed by breaks which are long enough to bring the gearbox back to ambient temperature (roughly 2 hours). In order to take the actual operating conditions into account, P_{t0} values have to be corrected with the following coefficients, thus obtaining the values of P_{tc} corrected thermal power.

1.11 Thermische Leistung

Für jeden Getriebetyp werden in den relativen Kapiteln die Nennwerte der P_{t0} thermischen Leistung angegeben [kW]. Diese Werte entsprechen der max. übertragbaren Antriebsleistung am Getriebe in Dauerbetrieb mit max. Umgebungstemperatur von 30°C, sodass die Öltemperatur unter 95°C bleibt.

P_{t0} Wert ist nicht zu beachten, falls Dauerbetrieb max. 1 - 2 Stunden dauert und von Unterbrechungen gefolgt wird, die lang genug sind, damit das Getriebe-temperatur zurück zur Umgebungstemperatur sinkt (ungefähr 2 Stunden).

P_{t0} Werte sollen durch die folgenden Koeffizienten verbessert werden, damit die reelle Betriebsbedingungen wirklich in Betracht gezogen werden. Mit der folgenden Formel erhält man die Werte der korrekte thermische Leistung P_{tc}.

$$P_{tc} = P_{t0} \cdot ft \cdot fv \cdot fu \quad [kW]$$

Dove:

- ft = coefficiente di temperatura ambiente
- fv = coefficiente di ventilazione
- fu = coefficiente di utilizzo

Where:

- ft = environment temperature coefficient
- fv = ventilation coefficient
- fu = utilization coefficient

Dabei ist:

- ft = Umwelt Temperaturkoeffizient
- fv = Luftkühlungskoeffizient
- fu = Anwendungskoeffizient

I coefficienti di correzione sono ricavabili dalle seguenti tabelle:

Corrective coefficients are shown in the following tables:

Verbesserungskoeffizienten sind aus der nachstehenden Tabelle zu entnehmen:

Ta (°C)	0	5	10	15	20	25	30	35	40	45	50
ft	1.46	1.38	1.31	1.23	1.15	1.1	1.0	0.92	0.85	0.77	0.69

Ta = Temperatura ambiente (°C)

Ta = ambient temperature (°C)

Ta = Umgebungstemperatur (°C)

fv = 1.45 con ventilazione forzata efficace con ventola dedicata

fv = 1.45 for forced ventilation with specific fan

fv = 1.45 bei Drucklüftung mit spezifischem Lüfterrad

fv = 1.25 con ventilazione forzata secondaria ad altri dispositivi (pulegge, ventole, motore, ecc.)

fv = 1.25 for forced ventilation secondary to other devices (pulleys, fans, motor, etc.)

fv = 1.25 bei Drucklüftung nebensächlich anderen Vorrichtungen (Scheiben, Lüfterräder, Motor, usw.)

fv = 1 refrigerazione naturale (situazione standard)

fv = 1 for natural cooling (standard situation)

fv = 1 natürliche Belüftung (Standard)

fv = 0.5 in ambiente chiuso e ristretto (carter)

fv = 0.5 in a close and narrow environment (case)

fv = 0.5 in engem und geschlossenem Raum (Gehäuse)

Dt (min)	10	20	30	40	50	60
fu	1.6	1.35	1.2	1.1	1.05	1

Dt = minuti di funzionamento in un'ora

Dt = minutes of operation per hour

Dt = Betriebsminuten pro Stunde

1.12 Selezione

1.12 Selection

1.12 Wahl

Scelta del riduttore

Selecting a gearbox

Wahl des Getriebes

A) n₁ = 1400, 2800, 900, 500 min⁻¹

Si sceglierà nelle tabelle delle prestazioni dei riduttori un gruppo che in corrispondenza di un rapporto prossimo a quello calcolato ammetta una potenza:

A) n₁ = 1400, 2800, 900, 500 min⁻¹

Consult the gearbox unit efficiency table; select a group whose ratio is close to the calculated ratio and which permits power:

A) n₁ = 1400, 2800, 900, 500 min⁻¹

Aus der Leistungstabellen ist eine Gruppe von Getrieben zu wählen, deren Übersetzungsverhältnis nahe zu dem berechneten Wert ist und die die folgende Leistung erlaubt:

$$P \geq P' \cdot FS'$$

Scelta del motoriduttore

Selecting a gearmotor

Wahl des Getriebemotors

B) FS = 1

Si cercherà nelle tabelle delle prestazioni dei motoriduttori un gruppo la cui potenza P1 corrisponda alla P' calcolata.

B) FS = 1

Consult the gear motor efficiency table and select a group having power P1 corresponding to calculated P'.

B) FS = 1

Wählen Sie aus der Leistungstabelle der motoren eine Gruppe, deren Leistung P1 der berechneten Leistung P' entspricht.

C) FS ≠ 1

La scelta dovrà essere effettuata come al punto A) verificando che la grandezza del motore da installare sia compatibile con quelle ammesse dal riduttore (IEC); ovviamente la potenza installata dovrà corrispondere al valore P' richiesto.

C) FS ≠ 1

Follow the instructions at point A), checking that the size of the motor to be installed is compatible with the gearbox unit (IEC); obviously, installed power must correspond to the required P' value.

C) FS ≠ 1

Folgen Sie die Weisungen unter A). Es ist zu prüfen, dass die Größe des zu installierenden Motor mit dem Getriebe kompatibel ist (IEC); die installierte Leistung soll dem erforderlichen P' Wert entsprechen.

Determinato il riduttore idoneo è necessario verificare che anche gli eventuali carichi aggiuntivi (radiali ed assiali) agenti sugli alberi in uscita e/o entrata rientrino nei valori ammissibili dati a catalogo.

In determinate condizioni applicative può diventare necessario verificare che la potenza assorbita dal riduttore non superi quella del limite termico riportata a catalogo, secondo quanto riportato al punto 1.10 relativamente alla potenza termica.

After having selected the proper gearbox, it is necessary to check out that possible additional loads (radial or axial) on the input and/or output shafts fall within the values reported in the catalogue.

Depending on the application, it might be necessary to check that the power absorbed by the gearbox does not exceed the thermal power limit reported in the catalogue as per paragraph 1.10.

Nachdem das geeignete Getriebe gewählt worden ist, muss es sichergestellt werden, dass zusätzlichen Radial- oder Axialbelastungen auf die Antriebs- oder Abtriebswelle unter den im Katalog gegebenen Werten fallen.

Abhängig von der Art der Anwendung ist es manchmal zu prüfen, dass die von Getriebe absorbierte Leistung unter der Wert der thermischen Leistung liegt, wie es in dem Katalog angegeben wird (Abschnitt 1.10).

1.13 Lubrificazione

Tutti i riduttori, eccetto X130 e K130, sono forniti completi di lubrificante sintetico a base PAG con indice di viscosità ISO VG320.

I cuscinetti dell'albero veloce vengono sempre lubrificati con grasso a base sintetica; altri cuscinetti vengono lubrificati solo se la posizione di montaggio non ne garantisce la corretta lubrificazione.

Una scelta oculata del tipo di lubrificante, in funzione delle condizioni operative e ambientali, consente ai riduttori di raggiungere le prestazioni ottimali.

Le prestazioni dei riduttori indicate nelle tabelle dei dati tecnici sono state calcolate considerando l'impiego di olio sintetico.

VISCOSITA'

E'uno dei parametri più importanti da considerare nella scelta di un olio ed è influenzabile da diversi parametri quali velocità, temperatura. Riportiamo sinteticamente le valutazioni generali per la scelta della giusta viscosità:

Viscosità alta

Usare per basse velocità di rotazione e/o temperature alte.
(Una viscosità troppo bassa in queste condizioni operative causa una usura precoce).

Viscosità bassa

Usare per alte velocità di rotazione e/o temperature basse.
(Una viscosità troppo elevata provoca diminuzione del rendimento e surriscaldamento).

ADDITIVI

In tutti gli oli minerali sono contenuti degli additivi antiusura, EP (più o meno energici), antiossidanti ed antischiuma. E' opportuno assicurarsi che essi siano blandi e non aggressivi nei confronti delle guarnizioni.

BASE DELL'OLIO

Può essere minerale o sintetica.
L'olio sintetico, compensa il costo più elevato con una serie di vantaggi:

- a) minor coefficiente d'attrito (quindi migliore rendimento)
- b) migliore stabilità nel tempo (possibile lubrificazione a vita)
- c) migliore indice di viscosità (migliore adattabilità alle varie temperature).

L'olio a base minerale come vantaggi ha il minore costo e un migliore comportamento in rodaggio.

1.13 Lubrication

All worm gearboxes, except for the type X130 and K130, are supplied with synthetic lubricant, PAG base, viscosity index ISO VG 320.

The bearings mounted on the input shaft are supplied with grease, synthetic base; the other bearings are lubricated only if the mounting position does not assure a correct lubrication.

Choose the lubricant according to operating and ambient conditions in order to ensure high gear unit performance.

Performance data, as shown in the specifications tables, refer to utilization of synthetic oil.

VISCOSITY

It is one of the most important parameters to be considered when selecting an oil; it depends on various factors such as speed and temperature. Following are general guidelines for choosing the correct viscosity:

High viscosity

*To be used for low rotation speed and/or high temperatures.
(Under these operating conditions a low viscosity causes premature wear).*

Low viscosity

*To be used for high rotation speed and/or low temperatures.
(High viscosity reduces efficiency and causes overheating).*

ADDITIVES

All mineral oils contain additives to protect against wear, EP (more or less strong), anti-oxidizing and anti-frothing. It is advisable to make sure that the action of such additives is bland and not too aggressive on the seals.

OIL BASE

*May be mineral or synthetic.
Synthetic oil compensates for the higher cost with a series of advantages :*

- a) *lower friction coefficient (consequently improved efficiency)*
- b) *better stability over time (possible life lubrication)*
- c) *better viscosity index (more adaptable to various temperatures).*

Mineral-base oils offer the advantages of costing less and performing better during the running-in period.

1.13 Schmierung

Alle Schneckenradgetriebe mit Ausnahme der Ausführung X130 und K130, werden mit synthetischem Schmiermittel auf PAG Basis und Viskosität Index ISO VG 320 geliefert.

Die Kugellager auf der Eingangswelle sind immer mit synthetischem Fett geliefert. Falls die Montage keine korrekte Schmierung versichert, dann sind die restlichen Lager mit Schmiermittel geliefert.

Das Untersetzungsgetriebe wird optimal arbeiten, wenn das richtige Schmiermittel je nach Betriebs- und Umgebungsbedingungen sorgfältig ausgewählt wird.

Daten über Getriebeleistung, wie es in den Tabellen der technischen Daten angegeben wird, beziehen sich auf Schmierung mit synthetischem Öl.

VISKOSITÄT

Die Viskosität ist eins der wichtigsten Merkmale, die bei der Auswahl des richtigen Öls zu beachten sind; sie wird von verschiedenen Parametern wie Geschwindigkeit und Temperatur beeinflusst. Im folgenden fassen wir die wichtigsten allgemeinen Hinweise für die Wahl der richtigen Viskosität zusammen:

Hohe Viskosität

Geeignet für niedrige Drehzahlen bzw. hohe Temperaturen. (Eine zu geringe Viskosität verursacht unter diesen Betriebsbedingungen frühen Verschleiß).

Geringe Viskosität

Geeignet für hohe Drehzahlen bzw. niedrige Temperaturen.
(Eine zu geringe Viskosität verursacht unter diesem Fall zu einer Verringerung des Wirkungsgrades und zur Überhitzung).

ZUSÄTZE















Alle Mineralöle enthalten Antiverschleißzusätze, EP (mehr oder weniger stark), Oxydationsschutzmittel und Schaumverhinderungs-Wirkstoffe. Es soll sichergestellt werden, daß diese Zusätze schwach sind und die Dichtungen nicht angreifen.

ÖLGRUNDLAGE

Es kann sich dabei um Mineralöl oder synthetisches Öl handeln.
Synthetisches Öl ist zwar teurer, bietet jedoch eine Reihe von Vorteilen:

- a) geringerer Reibungskoeffizient (demnach besserer Wirkungsgrad)
- b) bessere Stabilität über lange Zeit (lebenslange Schmierung möglich)
- c) besserer Viskositätsindex (paßt sich besser an verschiedene Temperaturen an).

Die Vorteile von Mineralöl sind die geringeren Kosten und das bessere Einfahrverhalten.

ISO VG	OLIO MINERALE / MINERAL OIL / MINERALÖL			OLIO SINTETICO / SYNTHETIC OIL / SYNTETISCHES ÖL						
	460	320	220	460	320	220	150			
Temperatura ambiente Amb.Temp. Ta (°C) Umgebungstemperatur	5° a 45°	0° a 40°	-5° a 35°	-15° a 100°	-20 a 90°	-25° a 80°	-30° a 70°			
FORNITORE / MANUFACTURER / HERSTELLER	MINERALE / MINERAL / MINERAL									
	MINERALE / MINER. / MINER.	SHELL		Omala OIL 460	Omala OIL 320	Omala OIL 220				
		BP		Energol GRXP 460	Energol GRXP 320	Energol GRXP 220				
		TEXACO		Meropa 460	Meropa 320	Meropa 220				
		CASTROL		Alpha SP 460	Alpha SP 320	Alpha SP 220				
		KLUBER		Lamora 460	Lamora 320	Lamora 220				
		MOBIL		Mobilgear 634	Mobilgear 632	Mobilgear 630				
	Tecnologia PAG (polialcoliglicoli) / PAG Technology (polyalkyleneglycol) / PAG (Polyalkylglikole)									
	PAG	SHELL					Omala S4 WE 460	Omala S4 WE 320	Omala S4 WE 220	Omala S4 WE 150
		BP					Energol SGXP460	Energol SGXP320	Energol SGXP220	Enersyn SG 150
		TEXACO					Synlube CLP 460	Synlube CLP 320	Synlube CLP 220	
		AGIP						Agip Blasias S 320	Agip Blasias S 220	Agip Blasias S 150
	Tecnologia PAO (polialcoliolefini) / PAO Technology (polyalphaolefin) / PAO (Polyalphaolefine)									
	PAO	SHELL					Omala OIL RL/HD 460	Omala OIL RL/HD 320	Omala OIL RL/HD 220	Omala OIL RL/HD 150
		CASTROL					Alpha Synt 460	Alpha Synt 320	Alpha Synt 220	Alpha Synt 150
		KLUBER					Synteso D460 EP	Synteso D320 EP	Synteso D220 EP	Synteso D150 EP
MOBIL						SHC 634	SHC 632	SHC 630	SHC 629	

1.14 Installazione

Fissare il riduttore in modo tale da evitare qualsiasi vibrazione e curare l'allineamento del riduttore con il motore e l'utenza utilizzando, quando è possibile, giunti di accoppiamento.

Assicurarsi che gli organi da montare sui riduttori abbiano le tolleranze ISO h6 per gli alberi e ISO H7 per i fori.

Se il riduttore viene installato all'aperto si consiglia l'utilizzo del tappo di sfiato con valvola, tranne le grandezze 30-40-50-63-75.

Tutti i riduttori e motoriduttori citati nel presente manuale sono destinati ad un impiego industriale con temperatura ambiente da -20°C a +40°C ad una altitudine max di 1000 m slm.

Per tutte le altre avvertenze consultare il manuale di "uso e manutenzione" scaricabile dal sito www.tramec.it

1.14 Installation

The gearbox has to be mounted to prevent any vibration. Check carefully the alignment gearbox / motor / machine and use couplings whenever possible. Check that devices to be mounted on the gearbox feature ISO h6 tolerance for the shafts and ISO H7 for the holes.

If the gearbox is installed outdoors, we recommend the use of the breather plug with valve, except size 30-40-50-63-75.

All reducers and gear motors mentioned in this catalog are intended for industrial use and operation at a ambient temperature between -20°C and +40°C, at an altitude of max. 1000 m above sea level.

For all other instructions check the "Use and Maintenance Manual" which can be downloaded from our web site www.tramec.it

1.14 Installation

Das Getriebe ist so zu installieren, dass allerart Schwingung vorbeugt wird. Auf die Fluchtung Getriebe / Motor / Maschine ist es besonders achtzugeben. Dabei sind Kupplungen womöglich zu benutzen. Die auf dem Getriebe montierten Elemente sollen die folgende Toleranz aufweisen: ISO h6 für die Wellen und ISO h7 für die Bohrungen.

Abgesehen von Größen 30-40-50-63-75, die Anwendung einer Entlüftungsschraube mit Ventil wird empfohlen, wenn das Getriebe im Freien eingebaut wird.

Alle im vorliegenden Katalog angegebenen Getriebe und Getriebemotoren sind für industriellen Einsatz in einer Umgebungstemperatur von -20°C bis +40°C und in einer max. Höhe von 1000 m über dem Meeresspiegel vorgesehen.

Für weitere Anweisungen laden Sie die "Betriebs- und Instandhaltungsanweisung" aus unsere Webseite www.tramec.it herunter.

1.15 Manutenzione

Tutti i riduttori a vite senza fine, eccetto X130 e K130, sono lubrificati a vita con olio sintetico tipo SHELL OMALA S4 WE 320.

Non necessitano quindi di particolari manutenzioni se non il mantenimento della pulizia esterna, evitando l'uso di solventi per non danneggiare guarnizioni o anelli di tenuta, ed il rispetto di tutte le indicazioni e della eventuale sostituzione dell'olio negli intervalli programmati e riportati nel manuale di "uso e manutenzione" scaricabile dal sito www.tramec.it

1.15 Maintenance

All worm gearboxes, except for the type X130 and K130, are lubricated for life with synthetic oil SHELL OMALA S4 WE 320.

For this reason they do not require any particular maintenance, except for external cleaning (avoid the use of solvents which might damage gaskets and oil seals) and observance of the schedules for oil change as reported in the "Use and Maintenance Manual" which can be downloaded from our web site www.tramec.it

1.15 Wartung

Alle Schneckengetriebe mit Ausnahme der Ausführung X130 und K130 sind mit synthetischem Öl SHELL OMALA S4 WE 320 lebenslang geschmiert.

Deshalb brauchen sie kein besonderes Instandhalten außer Aussenreinigung und Befolgung der Zeitabstände für Ölwechsel, wie es in der "Betriebs- und Instandhaltungsanweisung" auf unsere Webseite www.tramec.it angegeben wird. Bei der Aussenreinigung benutzen Sie keine Lösemittel, weil sie die Dichtungen beschädigen.

1.16 Verniciatura

Le carcasse in ghisa e le flange delle grandezze 90, 110 e 130 sono verniciate di colore BLU RAL 5010 mentre quelle in alluminio delle grandezze 75, 63, 50, 40 e 30 sono sabbiate.

1.16 Painting

Size 90, 110 and 130 have cast iron housings and flanges painted BLUE RAL 5010.

The housings of sizes 75, 63, 50, 40 and 30 are made in aluminium and sandblasted.

1.16 Lackierung

Die Gehäuse der Größen 90, 110 und 130 bestehen aus Gusseisen und sind BLAU RAL 5010 lackiert.

Für Größen 75, 63, 50, 40 und 30 ist das Gehäuse aus Aluminium und sandgestrahlt.

2.0	RIDUTTORI A VITE SENZA FINE X	X WORM GEARBOXES	SCHNECKENGETRIEBE X	
2.1	Caratteristiche	<i>Characteristics</i>	Merkmale	16
2.2	Designazione	<i>Designation</i>	Bezeichnung	17
2.3	Lubrificazione e posizioni di montaggio	<i>Lubrication and mounting position</i>	Schmierung und Einbaulage	18
2.4	Posizione morsettiera	<i>Terminal board position</i>	Lage des Klemmbrett	18
2.5	Dati tecnici	<i>Technical data</i>	Technische Daten	19
2.6	Momenti d'inerzia	<i>Moment of inertia</i>	Trägheitsmoment	27
2.7	Dimensioni	<i>Dimensions</i>	Abmessungen	30
2.8	Entrata supplementare	<i>Additional input</i>	Zusatzantrieb	35
2.9	Limitatore di coppia cavo passante	<i>Torque limiter with through hollow shaft</i>	Drehmomentbegrenzer mit durchgehender Hohlwelle	35
2.10	Accessori	<i>Accessories</i>	Zubehör	37
2.11	Lista parti di ricambio	<i>Spare parts list</i>	Ersatzteilliste	38

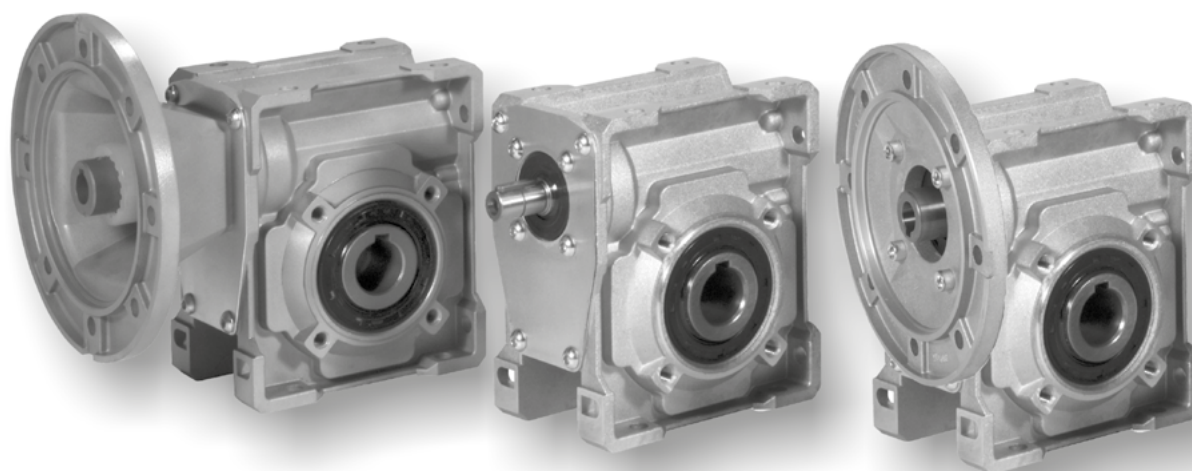

XF

XA

XC



2.1 Caratteristiche

- I riduttori a vite senza fine della serie X sono disponibili nelle versioni alberata XA e con predisposizione per attacco motore XF-XC.
- La versione XF (campana + giunto), caratterizzata da una più ampia versatilità ai diversi tipi di applicazioni, presenta un più elevato rendimento rispetto a quello della serie compatta XC la quale, a sua volta, presenta il vantaggio di un ingombro più ridotto.
- La carcassa monoblocco è in ghisa nelle grandezze 90, 110 e 130, in alluminio pressofuso per le grandezze inferiori.
- La vite senza fine è in acciaio legato cementato-temprato ed è rettificata.
- La corona ha il mozzo in ghisa con riporto di fusione dell'anello in bronzo.
- Le carcasse in ghisa sono verniciate BLU RAL5010 mentre quelle in alluminio sono sabbiate.
- Viene fornito l'albero uscita cavo di serie ed esiste un'ampia disponibilità di accessori: seconda entrata, cuscinetti conici sulla corona, flangia uscita, albero lento con 1 o 2 sporgenze, limitatore di coppia con cavo passante, braccio di reazione, kit protezione albero cavo, kit protezione limitatore di coppia.

2.1 Characteristics

- *X series worm gearboxes are available in the following versions : XA with shaft, XF and XC suitable for motor mounting assembling.*
- *The XF version (bell + joint) suits a wider range of applications and provides higher efficiency than the XC compact version, which actually offers reduced space requirement.*
- *The enbloc housing is in cast-iron for sizes 90, 110 and 130, in die-cast aluminium for smaller sizes.*
- *The worm shaft is in case-and quench-hardened alloy steel and ground.*
- *The worm wheel has a cast-iron hub provided with inserted cast-bronze ring.*
- *The housings in cast iron are painted BLUE RAL 5010, those in aluminium are sandblasted.*
- *The hollow output shaft is supplied as standard. A broad range of accessories is available: second input, tapered roller bearings on the worm wheel, output flange, single or double-extended output shaft, torque limiter with through hollow shaft, torque arm, hollow shaft protection kit, torque limiter protection kit.*

2.1 Merkmale

- Die Schneckengetriebe der Serie X sind in die Version XA mit Welle und XF / XC mit Motoranschluß lieferbar.
- Die Version XF (Glocke + Kupplung), die sich durch ihre zahlreichen Anwendungsmöglichkeiten auszeichnet, bietet höhere Leistung als die Kompaktserie XC, die wiederum Vorteile im Sinne der Platzersparnis mit sich bringt.
- Das Blockgehäuse ist aus Gusseisen für die Baugrößen 90, 110 und 130, aus Aluminiumdruckguß für die kleineren Versionen.
- Die Schnecke ist aus einsatzgehärtetem/abgeschrecktem und daraufhin geschliffenen Legierungsstahl.
- Das Schneckenrad besteht aus einer Nabe aus Gusseisen und einem aufgeschleuderten Gussbronze –Ring.
- Das Schneckenrad aus Gusseisen werden mit BLAU RAL 5010 lackiert, die aus Aluminium werden sandgestrahlt.
- Die Hohlwelle gehört zur serienmäßigen Ausstattung. Zahlreiches Zubehör ist lieferbar: zweiter Antrieb, Kegellager auf das Schneckenrad, Abtriebsflansch, Standard oder doppelseitig herausragende Abtriebswelle, Drehmomentbegrenzer mit durchgehender Hohlwelle, Drehmomentstütze, Schutzvorrichtung für Hohlwelle, Schutzvorrichtung für Drehmomentbegrenzer.

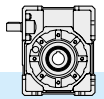

2.2 Designazione

2.2 Designation

2.2 Bezeichnung

Riduttore Gearbox Getriebe	Tipo entrata Input type Antriebsart	Grandezza Size Größe	Rapporto rid. Ratio Untersetzung	Predispos. att. mot. Motor coupling Motoranschluss	Posizione di mont. Mounting position Einbaulage	Flangia in uscita. Output flange Abtriebsflansch	Limitatore di coppia. Torque limiter Drehmomentbegrenzer	Seconda entrata Additional input Zusatzantrieb	Albero uscita Output shaft Abtriebswelle	Braccio di reazione Torque arm Drehmomentstütze
X	A	50	10/1	P.A.M	B3	F1S	LD	SeA	H	BR
Riduttore a vite senza fine Wormgearbox Schneckengetriebe	A	30	5	56		F1D-F2D-F3D	LD	SeA	H	BR
	C	40 50 63 75 90 110 130	7.5 10 15 20 25 30 40 50 65 80 100	63 71 80 90 100 112 132	B3, B6 B7, B8 V5, V6	F1S-F2S-F3S	LS	SD	SS	
	F					F12-F22-F32			DD	

Tipo entrata

Input type

Antriebstyp

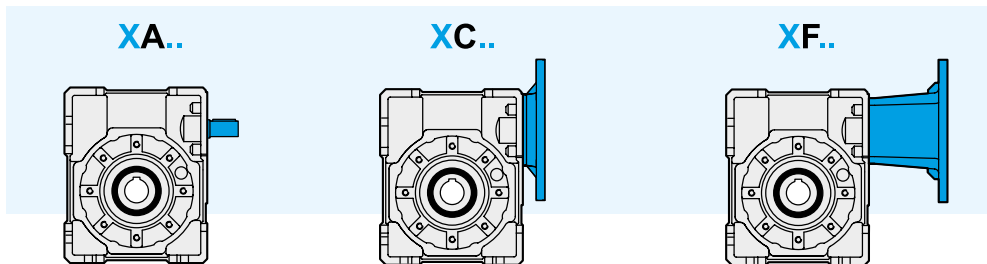

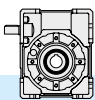

2.3 Lubrificazione

I riduttori a vite senza fine serie X, tranne la grandezza 130, sono forniti completi di lubrificante sintetico a base PAG con indice di viscosità ISO VG320. Si raccomanda di precisare sempre, in fase di ordine, la posizione di lavoro desiderata.

Posizioni di montaggio

2.3 Lubrication

X series worm gearboxes, except for the size 130, are supplied with synthetic lubricant, PAG base, viscosity index ISO VG320. Mounting position always to be specified when ordering.

Mounting positions

2.3 Schmierung

Schneckengetriebe der Serie X, außer Größe 130, werden mit synthetischem Schmiermittel auf PAG Basis und Viskosität Index ISO VG320 geliefert. Im Auftrag bitte immer die gewünschte Einbaulage angeben.

Einbaulagen

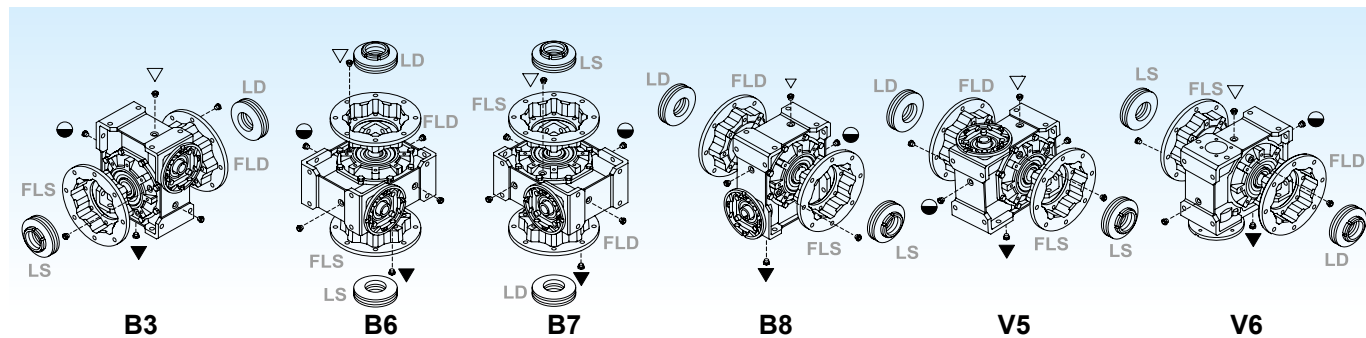

		Q.tà olio / Oil quantity / Schmiermittelmenge [lt]			
		Posizione di montaggio / Mounting position / Einbaulage			
		B3	B6 - B7	B8	V5 - V6
X	30	0.015	0.030	0.015	
	40	0.040	0.060	0.040	
	50	0.080	0.120	0.080	
	63	0.160	0.220	0.160	
	75	0.260	0.340	0.260	
	90	1.1	0.9	1	1.5
	110	2.2	1.8	1.6	2.6
	130	3.6	3	2.5	3.8

- ▽ Carico e sfiato / Filling and breather
Einfüll und Entlüftung
- Livello / Level / Ölstand
- ▼ Scarico / Drain / Ablass

Nei corpi in alluminio 30, 40, 50, 63,75 è presente un solo tappo di riempimento olio.

30, 40, 50, 63 and 75 aluminium housings have one oil filling plug only.

30, 40, 50, 63 und 75 Aluminiumgehäuse verfügen über 1 Einfüllschraube.

2.4 Posizione morsettiera

2.4 Terminal board position

2.4 Lage der Klemmenkaste

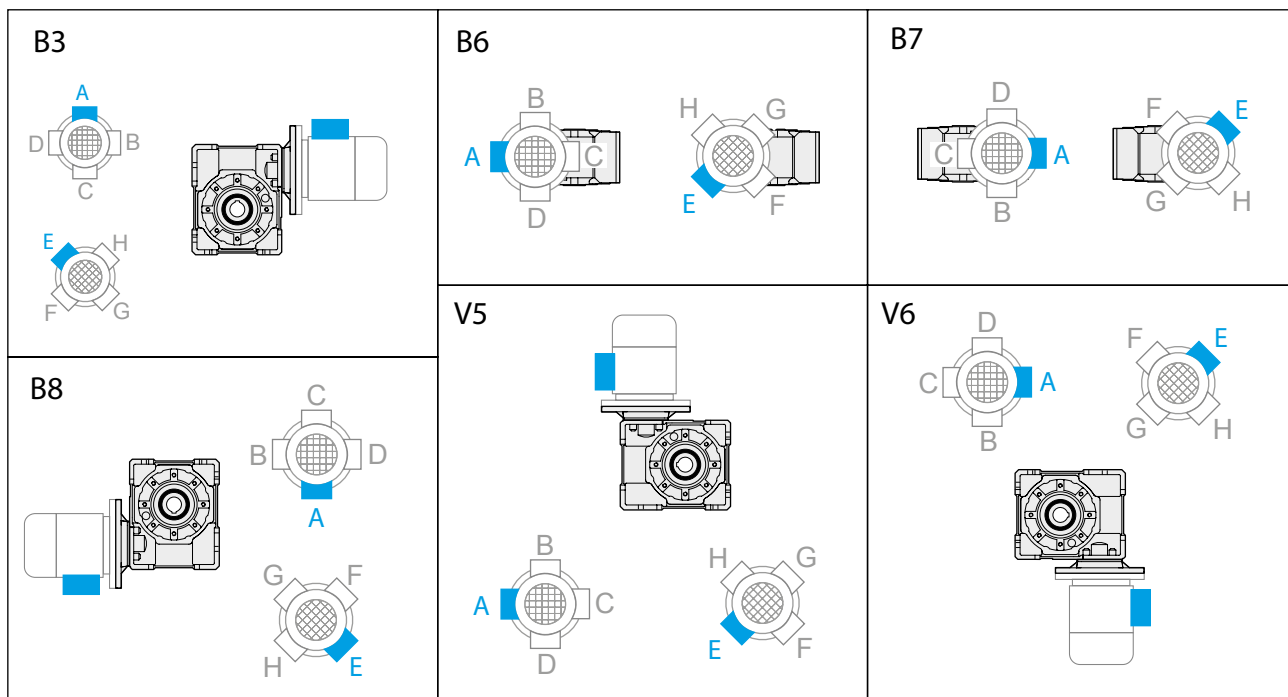

Specificare sempre in fase di ordinazione la posizione di montaggio e la forma costruttiva. Posizione morsettiera v. pag. 33-34 (PM=1; PM=2)

Mounting position always to be specified when ordering. Terminal board position see page 33-34 (PM=1; PM=2)

Bei der Bestellung immer die gewünschte Montageposition und Bauform angeben. Lage der Klemmenkaste Seite 33-34 (PM=1; PM=2)



2.5 Dati tecnici

2.5 Technical data

2.5 Technische Daten

30	$n_1 = 2800$				XA		XC - XF								
	i_n	n_2 [min ⁻¹]	Rd	P_{10}	T_{2M} [Nm]	P [kW]	T_2 [Nm]	P_1 [kW]	FS'	Input - IEC					
										XC B5/B14	XF				
Kg 1.4	5	560	0.89	—	14	0.92	5.6	0.37	2.5	63	56	63	56	63	56
	7.5	373	0.86		16	0.72	8	0.37	2.0						
	10	280	0.84		16	0.56	11	0.37	1.5						
	15	187	0.81		17	0.41	15	0.37	1.1						
	20	140	0.76		15	0.29	13	0.25	1.2						
	25	112	0.74		16	0.25	16	0.25	1.0						
	30	93	0.71		13	0.18	13	0.18	1.0						
	40	70	0.65		16	0.18	16	0.18	1.0						
	50	56	0.62		15	0.14	14	0.13	1.1						
	65	43	0.57		17	0.13	17	0.13	1.0						
80	35	0.54	13	0.09	13	0.09	1.0								
100	28	0.52	12	0.07	16	0.09	0.8	—							

30	$n_1 = 1400$				XA		XC - XF								
	i_n	n_2 [min ⁻¹]	Rd	P_{10}	T_{2M} [Nm]	P [kW]	T_2 [Nm]	P_1 [kW]	FS'	Input - IEC					
										XC B5/B14	XF				
Kg 1.4	5	280	0.87	0.40	19	0.64	6.5	0.22	2.9	63	56	63	56	63	56
	7.5	187	0.84	0.40	21	0.49	9	0.22	2.2						
	10	140	0.82	0.40	22	0.40	12	0.22	1.8						
	15	93	0.77	0.30	22	0.28	17	0.22	1.3						
	20	70	0.72	0.20	19	0.19	18	0.18	1.1						
	25	56	0.69	0.20	21	0.18	21	0.18	1.0						
	30	47	0.66	0.20	20	0.15	18	0.13	1.1						
	40	35	0.59	0.20	21	0.13	21	0.13	1.0						
	50	28	0.55	0.20	19	0.10	17	0.09	1.1						
	65	22	0.51	0.10	20	0.09	20	0.09	1.0						
80	18	0.48	0.10	17	0.06	16	0.06	1.0							
100	14	0.45	0.10	14	0.05	18	0.06	0.8	—						

30	$n_1 = 900$				XA		XC - XF								
	i_n	n_2 [min ⁻¹]	Rd	P_{10}	T_{2M} [Nm]	P [kW]	T_2 [Nm]	P_1 [kW]	FS'	Input - IEC					
										XC B5/B14	XF				
Kg 1.4	5	180	0.85	—	23	0.51	5.9	0.13	3.9	63	56	63	56	63	56
	7.5	120	0.82		25	0.38	9	0.13	2.9						
	10	90	0.80		25	0.30	11	0.13	2.3						
	15	60	0.75		25	0.21	15	0.13	1.6						
	20	45	0.69		22	0.15	19	0.13	1.2						
	25	36	0.66		24	0.14	23	0.13	1.1						
	30	30	0.63		21	0.10	18	0.09	1.2						
	40	23	0.55		24	0.10	21	0.09	1.1						
	50	18	0.52		21	0.08	16	0.06	1.1						
	65	14	0.48		22	0.07	20	0.06	1.1						
80	11	0.44	19	0.05	11	0.03	1.7								
100	9	0.42	15	0.03	13	0.03	1.1	—							

30	$n_1 = 500$				XA		XC - XF								
	i_n	n_2 [min ⁻¹]	Rd	P_{10}	T_{2M} [Nm]	P [kW]	T_2 [Nm]	P_1 [kW]	FS'	Input - IEC					
										XC B5/B14	XF				
Kg 1.4	5	100	0.83	—	29	0.36	—	—	—	63	56	63	56	63	56
	7.5	67	0.80		31	0.27	—	—	—						
	10	50	0.77		31	0.21	—	—	—						
	15	33	0.72		31	0.15	—	—	—						
	20	25	0.66		26	0.10	—	—	—						
	25	20	0.62		27	0.09	—	—	—						
	30	17	0.59		25	0.07	—	—	—						
	40	13	0.51		28	0.07	—	—	—						
	50	10	0.48		25	0.06	—	—	—						
	65	8	0.43		25	0.05	—	—	—						
80	6	0.40	20	0.03	—	—	—								
100	5	0.38	16	0.02	—	—	—	—							

* **ATTENZIONE:** la coppia massima utilizzabile $[T_{2M}]$ deve essere calcolata utilizzando il fattore di servizio: $T_{2M} = T_2 \times FS'$

* **WARNING:** Maximum allowable torque $[T_{2M}]$ must be calculated using the following service factor: $T_{2M} = T_2 \times FS'$

* **ACHTUNG:** das max. anwendbare Drehmoment $[T_{2M}]$ muss mit folgendem Betriebsfaktor berechnet werden: $T_{2M} = T_2 \times FS'$

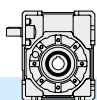

2.5 Dati tecnici

2.5 Technical data

2.5 Technische Daten

40	$n_1 = 2800$				XA		XC - XF											
	i_n	n_2 [min. ⁻¹]	Rd	P_{10}	T_{2M} [Nm]	P [kW]	T_2 [Nm]	P_1 [kW]	FS'	Input - IEC								
										XC			XF					
	B5/B14			B5		B14												
2.4 	5	560	0.88	—	25	1.67	11.3	0.75	2.2	71	63	—	71	63	56	71	63	—
	7.5	373	0.87		30	1.3	17	0.75	1.8									
	10	280	0.86		31	1.1	22	0.75	1.4									
	15	187	0.82		32	0.76	32	0.75	1.0									
	20	140	0.80		31	0.57	30	0.55	1.0									
	25	112	0.76		27	0.41	24	0.37	1.1									
	30	93	0.73		35	0.47	28	0.37	1.3									
	40	70	0.70		33	0.35	24	0.25	1.4									
	50	56	0.65		30	0.27	28	0.25	1.1									
	65	43	0.61		28	0.21	24	0.18	1.2									
80	35	0.58	26	0.16	21	0.13	1.3											
100	28	0.55	25	0.13	24	0.13	1.0											

40	$n_1 = 1400$				XA		XC - XF											
	i_n	n_2 [min. ⁻¹]	Rd	P_{10}	T_{2M} [Nm]	P [kW]	T_2 [Nm]	P_1 [kW]	FS'	Input - IEC								
										XC			XF					
	B5/B14			B5		B14												
2.4 	5	280	0.87	0.80	34	1.14	16.3	0.55	2.1	71	63	—	71	63	56	71	63	—
	7.5	187	0.85	0.80	40	0.92	24	0.55	1.7									
	10	140	0.83	0.70	41	0.73	31	0.55	1.3									
	15	93	0.79	0.50	42	0.52	30	0.37	1.4									
	20	70	0.76	0.50	40	0.39	38	0.37	1.0									
	25	56	0.72	0.40	35	0.29	31	0.25	1.1									
	30	47	0.68	0.40	41	0.29	35	0.25	1.2									
	40	35	0.64	0.30	38	0.22	38	0.22	1.0									
	50	28	0.59	0.30	38	0.19	36	0.18	1.1									
	65	22	0.54	0.20	35	0.15	31	0.13	1.1									
80	18	0.52	0.20	33	0.12	31	0.11	1.1										
100	14	0.49	0.20	28	0.08	30	0.09	0.9										

40	$n_1 = 900$				XA		XC - XF											
	i_n	n_2 [min. ⁻¹]	Rd	P_{10}	T_{2M} [Nm]	P [kW]	T_2 [Nm]	P_1 [kW]	FS'	Input - IEC								
										XC			XF					
	B5/B14			B5		B14												
2.4 	5	180	0.85	—	42	0.93	16.7	0.37	2.5	71	63	—	71	63	56	71	63	—
	7.5	120	0.83		48	0.72	25	0.37	2.0									
	10	90	0.81		48	0.56	32	0.37	1.5									
	15	60	0.76		49	0.40	45	0.37	1.1									
	20	45	0.74		46	0.29	39	0.25	1.2									
	25	36	0.69		42	0.23	33	0.18	1.3									
	30	30	0.65		48	0.23	37	0.18	1.3									
	40	23	0.61		42	0.16	33	0.13	1.3									
	50	18	0.55		42	0.14	38	0.13	1.1									
	65	14	0.51		39	0.11	32	0.09	1.2									
80	11	0.48	37	0.09	37	0.09	1.0											
100	9	0.45	30	0.06	29	0.06	1.0											

40	$n_1 = 500$				XA		XC - XF											
	i_n	n_2 [min. ⁻¹]	Rd	P_{10}	T_{2M} [Nm]	P [kW]	T_2 [Nm]	P_1 [kW]	FS'	Input - IEC								
										XC			XF					
	B5/B14			B5		B14												
2.4 	5	100	0.83	—	51	0.64	7.1	0.09	7.1	71	63	—	71	63	56	71	63	—
	7.5	67	0.81		58	0.50	10	0.09	5.5									
	10	50	0.79		59	0.39	14	0.09	4.4									
	15	33	0.73		59	0.28	19	0.09	3.1									
	20	25	0.70		55	0.20	24	0.09	2.3									
	25	20	0.65		48	0.15	28	0.09	1.7									
	30	17	0.61		58	0.17	31	0.09	1.8									
	40	13	0.57		52	0.12	39	0.09	1.3									
	50	10	0.51		51	0.11	44	0.09	1.2									
	65	8	0.46		45	0.08	52	0.09	0.9									
80	6	0.44	42	0.06	61*	0.09	0.7*											
100	5	0.41	32	0.04	71*	0.09	0.4*											

* **ATTENZIONE:** la coppia massima utilizzabile $[T_{2M}]$ deve essere calcolata utilizzando il fattore di servizio: $T_{2M} = T_2 \times FS'$

* **WARNING:** Maximum allowable torque $[T_{2M}]$ must be calculated using the following service factor: $T_{2M} = T_2 \times FS'$

* **ACHTUNG:** das max. anwendbare Drehmoment $[T_{2M}]$ muss mit folgendem Betriebsfaktor berechnet werden: $T_{2M} = T_2 \times FS'$

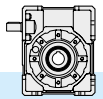

2.5 Dati tecnici

2.5 Technical data

2.5 Technische Daten

50	$n_1 = 2800$				XA		XC - XF											
	i_n	n_2 [min ⁻¹]	Rd	P_{10}	T_{2M} [Nm]	P [kW]	T_2 [Nm]	P_1 [kW]	FS'	Input - IEC								
										XC			XF					
	B5/B14			B5			B14											
Kg 4.0	5	560	0.89	—	44	2.9	22.8	1.5	1.9	80	71	—	80	71	63	80	71	—
	7.5	373	0.88		51	2.3	34	1.5	1.5									
	10	280	0.86		54	1.8	44	1.5	1.2									
	15	187	0.84		57	1.3	47	1.1	1.2									
	20	140	0.81		58	1.0	42	0.75	1.4									
	25	112	0.78		50	0.75	50	0.75	1.0									
	30	93	0.75		55	0.71	42	0.55	1.3									
	40	70	0.72		54	0.63	54	0.55	1.0									
	50	56	0.68		56	0.48	43	0.37	1.3									
	65	43	0.64		53	0.37	53	0.37	1.0									
	80	35	0.61		48	0.29	41	0.25	1.2									
	100	28	0.58		45	0.23	35	0.18	1.3									

50	$n_1 = 1400$				XA		XC - XF											
	i_n	n_2 [min ⁻¹]	Rd	P_{10}	T_{2M} [Nm]	P [kW]	T_2 [Nm]	P_1 [kW]	FS'	Input - IEC								
										XC			XF					
	B5/B14			B5			B14											
Kg 4.0	5	280	0.87	1.2	62	2.1	26.7	0.9	2.3	80	71	—	80	71	63	80	71	—
	7.5	187	0.86	1.2	70	1.6	40	0.9	1.8									
	10	140	0.84	1.0	73	1.3	52	0.9	1.4									
	15	93	0.80	0.80	74	0.90	74	0.9	1.0									
	20	70	0.78	0.70	75	0.71	58	0.55	1.3									
	25	56	0.74	0.60	65	0.51	47	0.37	1.4									
	30	47	0.71	0.60	66	0.46	53	0.37	1.2									
	40	35	0.67	0.50	69	0.38	68	0.37	1.0									
	50	28	0.62	0.40	70	0.33	53	0.25	1.3									
	65	22	0.58	0.40	64	0.25	64	0.25	1.0									
	80	18	0.54	0.40	60	0.20	53	0.18	1.1									
	100	14	0.51	0.30	55	0.16	45	0.13	1.2									

50	$n_1 = 900$				XA		XC - XF											
	i_n	n_2 [min ⁻¹]	Rd	P_{10}	T_{2M} [Nm]	P [kW]	T_2 [Nm]	P_1 [kW]	FS'	Input - IEC								
										XC			XF					
	B5/B14			B5			B14											
Kg 4.0	5	180	0.85	—	75	1.66	33.8	0.75	2.2	80	71	—	80	71	63	80	71	—
	7.5	120	0.84		83	1.23	50	0.75	1.6									
	10	90	0.82		86	0.98	66	0.75	1.3									
	15	60	0.78		88	0.71	68	0.55	1.3									
	20	45	0.75		87	0.54	59	0.37	1.5									
	25	36	0.71		75	0.40	70	0.37	1.1									
	30	30	0.67		79	0.37	79	0.37	1.0									
	40	23	0.63		75	0.28	67	0.25	1.1									
	50	18	0.59		80	0.26	78	0.25	1.0									
	65	14	0.54		74	0.20	67	0.18	1.1									
	80	11	0.51		67	0.16	56	0.13	1.2									
	100	9	0.47		58	0.12	45	0.09	1.3									

50	$n_1 = 500$				XA		XC - XF											
	i_n	n_2 [min ⁻¹]	Rd	P_{10}	T_{2M} [Nm]	P [kW]	T_2 [Nm]	P_1 [kW]	FS'	Input - IEC								
										XC			XF					
	B5/B14			B5			B14											
Kg 4.0	5	100	0.84	—	92	1.15	14.3	0.18	6.4	80	71	—	80	71	63	80	71	—
	7.5	67	0.82		100	0.85	21	0.18	4.7									
	10	50	0.80		104	0.68	28	0.18	3.8									
	15	33	0.75		106	0.49	39	0.18	2.7									
	20	25	0.72		104	0.38	50	0.18	2.1									
	25	20	0.68		88	0.27	58	0.18	1.5									
	30	17	0.63		98	0.27	65	0.18	1.5									
	40	13	0.59		95	0.21	81	0.18	1.2									
	50	10	0.54		94	0.18	93	0.18	1.0									
	65	8	0.50		86	0.14	56	0.09	1.5									
	80	6	0.46		77	0.11	63	0.09	1.2									
	100	5	0.43		61	0.07	74	0.09	0.8									

* **ATTENZIONE:** la coppia massima utilizzabile $[T_{2M}]$ deve essere calcolata utilizzando il fattore di servizio: $T_{2M} = T_2 \times FS'$

* **WARNING:** Maximum allowable torque $[T_{2M}]$ must be calculated using the following service factor: $T_{2M} = T_2 \times FS'$

* **ACHTUNG:** das max. anwendbare Drehmoment $[T_{2M}]$ muss mit folgendem Betriebsfaktor berechnet werden: $T_{2M} = T_2 \times FS'$



2.5 Dati tecnici

2.5 Technical data

2.5 Technische Daten

63	$n_1 = 2800$				XA		XC - XF											
	i_n	n_2 [min ⁻¹]	Rd	P_{10}	T_{2M} [Nm]	P [kW]	T_2 [Nm]	P_1 [kW]	FS'	Input - IEC								
										XC			XF					
	B5/B14			B5		B14												
Kg 6.6	5	560	0.89	—	79	5.2	45.5	3	1.7	90	80	—	90	80	71	90	80	—
	7.5	373	0.88		88	3.9	68	3	1.3									
	10	280	0.87		94	3.2	89	3	1.1									
	15	187	0.84		98	2.3	95	2.2	1.0									
	20	140	0.83		110	1.9	85	1.5	1.3									
	25	112	0.81		93	1.4	76	1.1	1.2									
	30	93	0.77		110	1.4	87	1.1	1.3									
	40	70	0.74		117	1.2	111	1.1	1.1									
	50	56	0.70		97	0.81	90	0.75	1.1									
	65	43	0.67		98	0.66	81	0.55	1.2									
80	35	0.64	91	0.52	65	0.37	1.4											
100	28	0.60	83	0.41	75	0.37	1.1											

63	$n_1 = 1400$				XA		XC - XF											
	i_n	n_2 [min ⁻¹]	Rd	P_{10}	T_{2M} [Nm]	P [kW]	T_2 [Nm]	P_1 [kW]	FS'	Input - IEC								
										XC			XF					
	B5/B14			B5		B14												
Kg 6.6	5	280	0.88	1.8	111	3.7	54	1.8	2.0	90	80	—	90	80	71	90	80	—
	7.5	187	0.87	1.8	120	2.7	80	1.8	1.5									
	10	140	0.85	1.6	127	2.2	105	1.8	1.2									
	15	93	0.81	1.2	130	1.6	125	1.5	1.1									
	20	70	0.80	1.2	144	1.3	120	1.1	1.2									
	25	56	0.77	1.0	118	0.90	118	0.9	1.0									
	30	47	0.73	0.90	142	0.95	134	0.9	1.1									
	40	35	0.69	0.80	150	0.79	142	0.75	1.1									
	50	28	0.65	0.70	122	0.55	122	0.55	1.0									
	65	22	0.61	0.60	122	0.45	100	0.37	1.2									
80	18	0.58	0.60	113	0.36	79	0.25	1.4										
100	14	0.53	0.50	102	0.28	91	0.25	1.1										

63	$n_1 = 900$				XA		XC - XF											
	i_n	n_2 [min ⁻¹]	Rd	P_{10}	T_{2M} [Nm]	P [kW]	T_2 [Nm]	P_1 [kW]	FS'	Input - IEC								
										XC			XF					
	B5/B14			B5		B14												
Kg 6.6	5	180	0.87	—	135	2.9	69	1.5	1.9	90	80	—	90	80	71	90	80	—
	7.5	120	0.85		144	2.1	102	1.5	1.4									
	10	90	0.83		150	1.7	133	1.5	1.1									
	15	60	0.79		152	1.2	139	1.1	1.1									
	20	45	0.77		167	1.0	123	0.75	1.4									
	25	36	0.74		140	0.71	109	0.55	1.3									
	30	30	0.70		164	0.74	122	0.55	1.3									
	40	23	0.66		171	0.61	154	0.55	1.1									
	50	18	0.61		141	0.44	120	0.37	1.2									
	65	14	0.57		139	0.35	98	0.25	1.4									
80	11	0.54	128	0.28	115	0.25	1.1											
100	9	0.50	115	0.22	95	0.18	1.2											

63	$n_1 = 500$				XA		XC - XF											
	i_n	n_2 [min ⁻¹]	Rd	P_{10}	T_{2M} [Nm]	P [kW]	T_2 [Nm]	P_1 [kW]	FS'	Input - IEC								
										XC			XF					
	B5/B14			B5		B14												
Kg 6.6	5	100	0.85	—	169	2.08	20	0.25	8.3	90	80	—	90	80	71	90	80	—
	7.5	67	0.83		177	1.5	30	0.25	5.9									
	10	50	0.81		182	1.2	39	0.25	4.7									
	15	33	0.76		184	0.84	55	0.25	3.4									
	20	25	0.74		200	0.70	71	0.25	2.8									
	25	20	0.71		165	0.49	85	0.25	1.9									
	30	17	0.65		195	0.52	94	0.25	2.1									
	40	13	0.62		201	0.43	118	0.25	1.7									
	50	10	0.56		165	0.31	135	0.25	1.2									
	65	8	0.52		161	0.25	163	0.25	1.0									
80	6	0.50	148	0.19	137	0.18	1.1											
100	5	0.45	122	0.14	77	0.09	1.6											

* **ATTENZIONE:** la coppia massima utilizzabile $[T_{2M}]$ deve essere calcolata utilizzando il fattore di servizio: $T_{2M} = T_2 \times FS'$

* **WARNING:** Maximum allowable torque $[T_{2M}]$ must be calculated using the following service factor: $T_{2M} = T_2 \times FS'$

* **ACHTUNG:** das max. anwendbare Drehmoment $[T_{2M}]$ muss mit folgendem Betriebsfaktor berechnet werden: $T_{2M} = T_2 \times FS'$



2.5 Dati tecnici

2.5 Technical data

2.5 Technische Daten

75	n₁ = 2800				XA		XC - XF											
	i _n	n ₂ [min ⁻¹]	Rd	P ₁₀	T _{2M} [Nm]	P [kW]	T ₂ [Nm]	P ₁ [kW]	FS'	Input - IEC								
										XC			XF			B5		
	B5/B14			B5			B14			B5			B14					
Kg 11.0	7.5	373	0.89	—	131	5.8	125	5.5	1.0	112 100	90	—	112 100	90	80	112 100	90	—
	10	280	0.88		143	4.8	120	4	1.2									
	15	187	0.85		152	3.5	131	3	1.2									
	20	140	0.84		172	3.0	171	3	1.0									
	25	112	0.82		155	2.2	154	2.2	1.0									
	30	93	0.78		170	2.1	120	1.5	1.4									
	40	70	0.75		183	1.8	154	1.5	1.2									
	50	56	0.73		166	1.3	136	1.1	1.2									
	65	43	0.69		155	1.0	114	0.75	1.4									
	80	35	0.66		145	0.80	135	0.75	1.1									
100	28	0.62	131	0.62	159	0.75	0.8	—	80	—	—	—	—	—	—	—		

75	n₁ = 1400				XA		XC - XF											
	i _n	n ₂ [min ⁻¹]	Rd	P ₁₀	T _{2M} [Nm]	P [kW]	T ₂ [Nm]	P ₁ [kW]	FS'	Input - IEC								
										XC			XF			B5		
	B5/B14			B5			B14			B5			B14					
Kg 11.0	7.5	187	0.87	2.5	180	4.0	178	4	1.0	112 100	90	—	112 100	90	80	112 100	90	—
	10	140	0.86	2.3	193	3.3	176	3	1.1									
	15	93	0.83	1.9	202	2.4	187	2.2	1.1									
	20	70	0.81	1.7	226	2.0	199	1.8	1.1									
	25	56	0.78	1.5	202	1.5	200	1.5	1.0									
	30	47	0.74	1.2	220	1.5	167	1.1	1.3									
	40	35	0.71	1.1	235	1.2	213	1.1	1.1									
	50	28	0.67	1.0	211	0.92	206	0.9	1.0									
	65	22	0.63	0.90	195	0.70	154	0.55	1.3									
	80	18	0.60	0.80	182	0.55	180	0.55	1.0									
100	14	0.56	0.70	162	0.43	210	0.55	0.8	—	80	—	—	—	—	—	—		

75	n₁ = 900				XA		XC - XF											
	i _n	n ₂ [min ⁻¹]	Rd	P ₁₀	T _{2M} [Nm]	P [kW]	T ₂ [Nm]	P ₁ [kW]	FS'	Input - IEC								
										XC			XF			B5		
	B5/B14			B5			B14			B5			B14					
Kg 11.0	7.5	120	0.86	—	215	3.1	205	3	1.0	112 100	90	—	112 100	90	80	112 100	90	—
	10	90	0.84		229	2.6	197	2.2	1.2									
	15	60	0.81		237	1.9	231	1.8	1.0									
	20	45	0.78		263	1.6	250	1.5	1.1									
	25	36	0.76		233	1.2	221	1.1	1.1									
	30	30	0.71		254	1.1	249	1.1	1.0									
	40	23	0.67		270	0.94	214	0.75	1.3									
	50	18	0.64		241	0.71	186	0.55	1.3									
	65	14	0.59		221	0.54	151	0.37	1.5									
	80	11	0.56		205	0.43	177	0.37	1.2									
100	9	0.52	184	0.34	203	0.37	0.9	—	80	—	—	—	—	—	—	—		

75	n₁ = 500				XA		XC - XF											
	i _n	n ₂ [min ⁻¹]	Rd	P ₁₀	T _{2M} [Nm]	P [kW]	T ₂ [Nm]	P ₁ [kW]	FS'	Input - IEC								
										XC			XF			B5		
	B5/B14			B5			B14			B5			B14					
Kg 11.0	7.5	67	0.84	—	265	2.2	90	0.75	2.9	112 100	90	—	112 100	90	80	112 100	90	—
	10	50	0.82		279	1.8	118	0.75	2.4									
	15	33	0.78		286	1.3	167	0.75	1.7									
	20	25	0.75		315	1.1	216	0.75	1.5									
	25	20	0.72		278	0.80	260	0.75	1.1									
	30	17	0.67		302	0.79	288	0.75	1.1									
	40	13	0.63		317	0.66	265	0.55	1.2									
	50	10	0.59		282	0.50	210	0.37	1.3									
	65	8	0.55		257	0.38	251	0.37	1.0									
	80	6	0.52		238	0.30	197	0.25	1.2									
100	5	0.47	206	0.23	161	0.18	1.3	—	80	—	—	—	—	—	—	—		

* **ATTENZIONE:** la coppia massima utilizzabile [T_{2M}] deve essere calcolata utilizzando il fattore di servizio: T_{2M} = T₂ x FS'

* **WARNING:** Maximum allowable torque [T_{2M}] must be calculated using the following service factor : T_{2M} = T₂ x FS'

* **ACHTUNG:** das max. anwendbare Drehmoment [T_{2M}] muss mit folgendem Betriebsfaktor berechnet werden: T_{2M} = T₂ x FS'

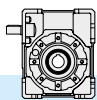

2.5 Dati tecnici

2.5 Technical data

2.5 Technische Daten

90	n₁ = 2800				XA		XC - XF											
	i _n	n ₂ [min. ⁻¹]	Rd	P ₁₀	T _{2M} [Nm]	P [kW]	T ₂ [Nm]	P ₁ [kW]	FS'	XC		Input - IEC						
										B5/B14		B5			XF			
 23.6	7.5	373	0.89	—	209	9.2	171	7.5	1.2	112 100	90	—	112 100	90	80	112 100	90	—
	10	280	0.88		223	7.4	165	5.5	1.3									
	15	187	0.86		241	5.5	241	5.5	1.0									
	20	140	0.84		272	4.7	230	4	1.2									
	25	112	0.83		255	3.6	212	3	1.2									
	30	93	0.79		270	3.3	243	3	1.1									
	40	70	0.77		293	2.8	230	2.2	1.3									
	50	56	0.74		278	2.2	278	2.2	1.0									
	65	43	0.71		250	1.6	235	1.5	1.1									
	80	35	0.68		238	1.3	205	1.1	1.2									
100	28	0.64	212	0.97	163	0.75	1.3	—	80									

90	n₁ = 1400				XA		XC - XF											
	i _n	n ₂ [min. ⁻¹]	Rd	P ₁₀	T _{2M} [Nm]	P [kW]	T ₂ [Nm]	P ₁ [kW]	FS'	XC		Input - IEC						
										B5/B14		B5			XF			
 23.6	7.5	187	0.88	3.0	290	6.5	247	5.5	1.2	112 100	90	—	112 100	90	80	112 100	90	—
	10	140	0.86	2.5	305	5.2	236	4	1.3									
	15	93	0.84	2.2	320	3.7	256	3	1.2									
	20	70	0.82	2.0	360	3.2	334	3	1.1									
	25	56	0.80	1.8	332	2.4	299	2.2	1.1									
	30	47	0.76	1.5	350	2.3	340	2.2	1.0									
	40	35	0.72	1.3	377	1.9	355	1.8	1.1									
	50	28	0.69	1.1	353	1.5	353	1.5	1.0									
	65	22	0.65	1.0	317	1.1	317	1.1	1.0									
	80	18	0.63	1.0	309	0.90	309	0.9	1.0									
100	14	0.58	0.80	264	0.67	217	0.55	1.2	—	80								

90	n₁ = 900				XA		XC - XF											
	i _n	n ₂ [min. ⁻¹]	Rd	P ₁₀	T _{2M} [Nm]	P [kW]	T ₂ [Nm]	P ₁ [kW]	FS'	XC		Input - IEC						
										B5/B14		B5			XF			
 23.6	7.5	120	0.86	—	345	5.0	206	3	1.7	112 100	90	—	112 100	90	80	112 100	90	—
	10	90	0.85		362	4.0	270	3	1.3									
	15	60	0.82		377	2.9	286	2.2	1.3									
	20	45	0.79		419	2.5	371	2.2	1.1									
	25	36	0.77		385	1.9	369	1.8	1.0									
	30	30	0.73		416	1.8	416	1.8	1.0									
	40	23	0.69		440	1.5	440	1.5	1.0									
	50	18	0.66		398	1.1	384	1.1	1.0									
	65	14	0.62		358	0.84	319	0.75	1.1									
	80	11	0.59		337	0.68	274	0.55	1.2									
100	9	0.54	313	0.55	313	0.55	1.0	—	80									

90	n₁ = 500				XA		XC - XF											
	i _n	n ₂ [min. ⁻¹]	Rd	P ₁₀	T _{2M} [Nm]	P [kW]	T ₂ [Nm]	P ₁ [kW]	FS'	XC		Input - IEC						
										B5/B14		B5			XF			
 23.6	7.5	67	0.84	—	430	3.6	91	0.75	4.7	112 100	90	—	112 100	90	80	112 100	90	—
	10	50	0.83		443	2.8	118	0.75	3.7									
	15	33	0.79		456	2.0	169	0.75	2.7									
	20	25	0.76		502	1.7	219	0.75	2.3									
	25	20	0.74		459	1.3	265	0.75	1.7									
	30	17	0.68		483	1.2	294	0.75	1.6									
	40	13	0.65		512	1.0	371	0.75	1.4									
	50	10	0.61		467	0.80	439	0.75	1.1									
	65	8	0.57		417	0.59	388	0.55	1.1									
	80	6	0.54		391	0.48	305	0.37	1.3									
100	5	0.49	345	0.37	344	0.37	1.0	—	80									

* **ATTENZIONE:** la coppia massima utilizzabile [T_{2M}] deve essere calcolata utilizzando il fattore di servizio: T_{2M} = T₂ x FS'

* **WARNING:** Maximum allowable torque [T_{2M}] must be calculated using the following service factor: T_{2M} = T₂ x FS'

* **ACHTUNG:** das max. anwendbare Drehmoment [T_{2M}] muss mit folgendem Betriebsfaktor berechnet werden: T_{2M} = T₂ x FS'

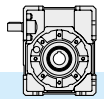

2.5 Dati tecnici

2.5 Technical data

2.5 Technische Daten

110	$n_1 = 2800$				XA		XC - XF											
	i_n	n_2 [min ⁻¹]	Rd	P_{10}	T_{2M} [Nm]	P [kW]	T_2 [Nm]	P_1 [kW]	FS'	Input - IEC								
										XC			XF					
	B5/B14			B5			B14											
Kg 44.0	7.5	373	0.89	—	345	15.1	343	15	1.0	132	112 100	—	132	112 100	90	132	—	—
	10	280	0.88		368	12.2	332	11	1.1									
	15	187	0.86		404	9.2	331	7.5	1.2									
	20	140	0.85		465	8.0	435	7.5	1.1									
	25	112	0.84		441	6.2	393	5.5	1.1									
	30	93	0.80		459	5.6	450	5.5	1.0									
	40	70	0.78		503	4.7	424	4	1.2									
	50	56	0.76		476	3.7	388	3	1.2									
	65	43	0.73		417	2.6	354	2.2	1.2									
	80	35	0.70		400	2.1	287	1.5	1.4									
100	28	0.66	364	1.6	339	1.5	1.1											

110	$n_1 = 1400$				XA		XC - XF											
	i_n	n_2 [min ⁻¹]	Rd	P_{10}	T_{2M} [Nm]	P [kW]	T_2 [Nm]	P_1 [kW]	FS'	Input - IEC								
										XC			XF					
	B5/B14			B5			B14											
Kg 44.0	7.5	187	0.88	4.3	480	10.6	415	9.2	1.2	132	112 100	—	132	112 100	90	132	—	—
	10	140	0.87	4.0	504	8.5	446	7.5	1.1									
	15	93	0.84	3.2	543	6.3	475	5.5	1.1									
	20	70	0.83	3.0	623	5.5	623	5.5	1.0									
	25	56	0.81	2.7	578	4.2	554	4	1.0									
	30	47	0.77	2.2	601	3.8	472	3	1.3									
	40	35	0.74	2.0	650	3.2	606	3	1.1									
	50	28	0.72	1.8	608	2.5	538	2.2	1.1									
	65	22	0.68	1.6	528	1.8	451	1.5	1.2									
	80	18	0.65	1.5	503	1.4	390	1.1	1.3									
100	14	0.61	1.3	458	1.1	458	1.1	1.0										

110	$n_1 = 900$				XA		XC - XF											
	i_n	n_2 [min ⁻¹]	Rd	P_{10}	T_{2M} [Nm]	P [kW]	T_2 [Nm]	P_1 [kW]	FS'	Input - IEC								
										XC			XF					
	B5/B14			B5			B14											
Kg 44.0	7.5	120	0.87	—	578	8.3	381	5.5	1.5	132	112 100	—	132	112 100	90	132	—	—
	10	90	0.86		600	6.6	500	5.5	1.2									
	15	60	0.83		641	4.9	526	4	1.2									
	20	45	0.81		720	4.2	685	4	1.1									
	25	36	0.79		672	3.2	628	3	1.1									
	30	30	0.74		697	2.9	520	2.2	1.3									
	40	23	0.71		749	2.5	664	2.2	1.1									
	50	18	0.68		697	1.9	653	1.8	1.1									
	65	14	0.64		603	1.4	487	1.1	1.2									
	80	11	0.61		571	1.1	570	1.1	1.0									
100	9	0.57	513	0.85	450	0.75	1.1											

110	$n_1 = 500$				XA		XC - XF											
	i_n	n_2 [min ⁻¹]	Rd	P_{10}	T_{2M} [Nm]	P [kW]	T_2 [Nm]	P_1 [kW]	FS'	Input - IEC								
										XC			XF					
	B5/B14			B5			B14											
Kg 44.0	7.5	67	0.85	—	718	5.9	183	1.5	3.9	132	112 100	—	132	112 100	90	132	—	—
	10	50	0.84		738	4.6	240	1.5	3.1									
	15	33	0.80		778	3.4	344	1.5	2.3									
	20	25	0.78		866	2.9	446	1.5	1.9									
	25	20	0.76		802	2.2	542	1.5	1.5									
	30	17	0.70		832	2.1	603	1.5	1.4									
	40	13	0.67		886	1.7	765	1.5	1.2									
	50	10	0.64		820	1.3	671	1.1	1.2									
	65	8	0.59		705	0.96	553	0.75	1.3									
	80	6	0.56		664	0.77	643	0.75	1.0									
100	5	0.52	594	0.60	542	0.55	1.1											

* **ATTENZIONE:** la coppia massima utilizzabile $[T_{2M}]$ deve essere calcolata utilizzando il fattore di servizio: $T_{2M} = T_2 \times FS'$

* **WARNING:** Maximum allowable torque $[T_{2M}]$ must be calculated using the following service factor: $T_{2M} = T_2 \times FS'$

* **ACHTUNG:** das max. anwendbare Drehmoment $[T_{2M}]$ muss mit folgendem Betriebsfaktor berechnet werden: $T_{2M} = T_2 \times FS'$

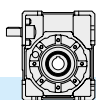

2.5 Dati tecnici

2.5 Technical data

2.5 Technische Daten

130	$n_1 = 2800$				XA		XC - XF									
	i_n	n_2 [min. ⁻¹]	Rd	P_{10}	T_{2M} [Nm]	P [kW]	T_2 [Nm]	P_1 [kW]	FS'	XC			Input - IEC			XF
										B5/B14			B5			
Kg 55.0	7.5	373	0.90	—	530	23	345	15	1.5	132	112 100	—	132	112 100	90	—
	10	280	0.89		549	18.1	455	15	1.2							
	15	187	0.87		636	14.3	490	11	1.3							
	20	140	0.86		733	12.5	645	11	1.1							
	25	112	0.85		710	9.8	667	9.2	1.1							
	30	93	0.81		729	8.8	622	7.5	1.2							
	40	70	0.80		819	7.5	819	7.5	1.0							
	50	56	0.78		758	5.7	732	5.5	1.0							
	65	43	0.75		648	3.9	499	3	1.3							
	80	35	0.73		637	3.2	598	3	1.1							
100	28	0.70	597	2.5	525	2.2	1.1									

130	$n_1 = 1400$				XA		XC - XF									
	i_n	n_2 [min. ⁻¹]	Rd	P_{10}	T_{2M} [Nm]	P [kW]	T_2 [Nm]	P_1 [kW]	FS'	XC			Input - IEC			XF
										B5/B14			B5			
Kg 55.0	7.5	187	0.89	6.0	736	16.2	418	9.2	1.8	132	112 100	—	132	112 100	90	—
	10	140	0.88	5.5	756	12.6	552	9.2	1.4							
	15	93	0.85	4.4	855	9.8	803	9.2	1.1							
	20	70	0.84	4.1	974	8.5	860	7.5	1.1							
	25	56	0.83	3.9	920	6.5	778	5.5	1.2							
	30	47	0.79	3.2	947	5.9	883	5.5	1.1							
	40	35	0.76	2.8	1037	5.0	829	4	1.3							
	50	28	0.74	2.6	959	3.8	757	3	1.3							
	65	22	0.71	2.3	801	2.6	678	2.2	1.2							
	80	18	0.68	2.1	758	2.1	649	1.8	1.2							
100	14	0.64	1.8	699	1.6	655	1.5	1.1								

130	$n_1 = 900$				XA		XC - XF									
	i_n	n_2 [min. ⁻¹]	Rd	P_{10}	T_{2M} [Nm]	P [kW]	T_2 [Nm]	P_1 [kW]	FS'	XC			Input - IEC			XF
										B5/B14			B5			
Kg 55.0	7.5	120	0.88	—	889	12.7	385	5.5	2.3	132	112 100	—	132	112 100	90	—
	10	90	0.87		905	9.8	508	5.5	1.8							
	15	60	0.84		1016	7.6	735	5.5	1.4							
	20	45	0.82		1149	6.6	957	5.5	1.2							
	25	36	0.81		1074	5.0	860	4	1.3							
	30	30	0.76		1113	4.6	968	4	1.2							
	40	23	0.73		1208	3.9	930	3	1.3							
	50	18	0.70		1077	2.9	817	2.2	1.3							
	65	14	0.67		924	2.0	832	1.8	1.1							
	80	11	0.64		869	1.6	815	1.5	1.1							
100	9	0.60	828	1.3	700	1.1	1.2									

130	$n_1 = 500$				XA		XC - XF									
	i_n	n_2 [min. ⁻¹]	Rd	P_{10}	T_{2M} [Nm]	P [kW]	T_2 [Nm]	P_1 [kW]	FS'	XC			Input - IEC			XF
										B5/B14			B5			
Kg 55.0	7.5	67	0.86	—	1109	9.0	228	1.85	4.9	132	112 100	—	132	112 100	90	—
	10	50	0.84		1107	6.9	297	1.85	3.7							
	15	33	0.81		1230	5.3	429	1.85	2.9							
	20	25	0.79		1388	4.6	558	1.85	2.5							
	25	20	0.78		1266	3.4	689	1.85	1.8							
	30	17	0.72		1320	3.2	763	1.85	1.7							
	40	13	0.69		1423	2.7	975	1.85	1.5							
	50	10	0.66		1261	2.0	1166	1.85	1.1							
	65	8	0.63		1095	1.4	860	1.10	1.3							
	80	6	0.59		1082	1.2	992	1.10	1.1							
100	5	0.55	945	0.9	788	0.75	1.2									

* **ATTENZIONE:** la coppia massima utilizzabile $[T_{2M}]$ deve essere calcolata utilizzando il fattore di servizio: $T_{2M} = T_2 \times FS'$

* **WARNING:** Maximum allowable torque $[T_{2M}]$ must be calculated using the following service factor: $T_{2M} = T_2 \times FS'$

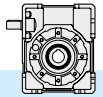

* **ACHTUNG:** das max. anwendbare Drehmoment $[T_{2M}]$ muss mit folgendem Betriebsfaktor berechnet werden: $T_{2M} = T_2 \times FS'$









2.6 **Momenti d'inerzia** [Kg·cm²]
(riferiti all'albero veloce in entrata)

2.6 **Moments of inertia** [Kg·cm²]
(referred to input shaft)

2.6 **Trägheitsmoment** [Kg·cm²]
(bez. Antriebswelle)

X30	i_n	XA 	XC 		XF 	
			B5 - B14		B5 - B14	
			IEC 56	IEC 63	IEC 56	IEC 63
5	0.077	0.130	0.127	0.122	0.123	
7.5	0.058	0.112	0.109	0.102	0.103	
10	0.049	0.103	0.100	0.093	0.094	
15	0.042	0.097	0.094	0.087	0.087	
20	0.039	0.095	0.092	0.084	0.084	
25	0.038	0.094	0.091	0.083	0.083	
30	0.038	0.093	0.090	0.083	0.084	
40	0.037	0.093	0.090	0.082	0.082	
50	0.037	0.092	0.089	0.081	0.082	
65	0.024	0.079	-	0.069	0.069	
80	0.024	0.079	-	0.069	0.069	
100	0.024	0.078	-	0.069	0.069	

X40	i_n	XA 	XC 			XF 		
			B5 - B14			B5	B5 - B14	
			IEC 56	IEC 63	IEC 71	IEC 56	IEC 63	IEC 71
5	0.242	-	0.391	0.463	0.289	0.447	0.464	
7.5	0.170	-	0.321	0.356	0.217	0.375	0.391	
10	0.144	-	0.272	0.347	0.190	0.348	0.365	
15	0.125	-	0.266	0.340	0.171	0.329	0.346	
20	0.094	-	0.263	0.338	0.141	0.298	0.315	
25	0.091	-	0.262	0.337	0.137	0.295	0.312	
30	0.113	-	0.262	0.337	0.160	0.318	0.335	
40	0.087	-	0.261	-	0.134	0.292	0.309	
50	0.087	0.182	0.261	-	0.133	0.291	0.308	
65	0.069	0.182	0.261	-	0.116	0.274	0.290	
80	0.069	0.182	0.261	-	0.115	0.273	0.290	
100	0.068	0.182	0.261	-	0.115	0.273	0.290	



X50	i_n	XA 	XC 			XF 		
			B5 - B14			B5	B5 - B14	
			IEC 63	IEC 71	IEC 80	IEC 63	IEC 71	IEC 80
5	0.744	-	0.922	1.046	0.978	0.955	1.558	
7.5	0.499	-	0.684	0.935	0.733	0.750	1.313	
10	0.417	-	0.602	0.853	0.651	0.668	1.231	
15	0.358	-	0.543	0.794	0.593	0.609	1.173	
20	0.281	-	0.523	0.774	0.516	0.532	1.096	
25	0.272	-	0.513	0.764	0.506	0.523	1.086	
30	0.323	-	0.508	0.759	0.557	0.574	1.137	
40	0.262	0.315	0.503	-	0.496	0.513	1.076	
50	0.183	0.313	0.501	-	0.417	0.434	0.997	
65	0.136	0.311	0.499	-	0.370	0.387	0.950	
80	0.136	0.310	0.498	-	0.370	0.387	0.950	
100	0.135	0.309	0.498	-	0.370	0.386	0.950	









2.6 **Momenti d'inerzia** [Kg·cm²]
(riferiti all'albero veloce in entrata)

2.6 **Moments of inertia** [Kg·cm²]
(referred to input shaft)

2.6 **Trägheitsmoment** [Kg·cm²]
(bez. Antriebswelle)

X63	i_n	XA 	XC 			XF 		
			B5 - B14			B5	B5 - B14	
			IEC 71	IEC 80	IEC 90	IEC 71	IEC 80	IEC 90
5	1.853	-	2.431	2.671	2.632	2.766	3.844	
7.5	1.363	-	1.949	2.269	2.142	2.276	3.354	
10	1.158	-	1.744	2.063	1.936	2.070	3.148	
15	1.011	-	1.597	1.916	1.789	1.924	3.001	
20	0.710	-	1.545	1.864	1.489	1.623	2.701	
25	0.679	-	1.514	1.833	1.458	1.592	2.670	
30	0.922	-	1.508	1.828	1.701	1.835	2.913	
40	0.660	0.966	1.495	-	1.439	1.573	2.651	
50	0.653	0.959	1.488	-	1.431	1.565	2.643	
65	0.552	0.955	1.484	-	1.330	1.465	2.542	
80	0.550	0.953	1.482	-	1.329	1.463	2.541	
100	0.549	0.952	1.481	-	1.327	1.462	2.539	

X75	i_n	XA 	XC 			XF 		
			B5 - B14			B5	B5 - B14	
			IEC 80	IEC 90	IEC 100-112	IEC 80	IEC 90	IEC 100-112
7.5	2.970	-	3.712	4.462	5.138	5.066	6.837	
10	2.492	-	3.234	3.984	4.661	4.588	6.359	
15	2.151	-	2.893	3.643	4.320	4.247	6.018	
20	1.567	-	2.774	3.523	3.735	3.662	5.433	
25	1.501	-	2.709	3.458	3.670	3.597	5.368	
30	1.946	-	2.689	3.438	4.115	4.042	5.813	
40	1.451	1.595	2.659	-	3.620	3.547	5.318	
50	1.435	1.578	2.642	-	3.603	3.531	5.302	
65	1.158	1.569	2.633	-	3.326	3.253	5.024	
80	1.153	1.565	2.629	-	3.322	3.249	5.020	
100	1.150	1.562	2.626	-	3.318	3.246	5.017	



X90	i_n	XA 	XC 			XF 		
			B5 - B14			B5	B5 - B14	
			IEC 80	IEC 90	IEC 100-112	IEC 80	IEC 90	IEC 100-112
7.5	6.167	-	6.898	7.671	8.335	8.263	10.033	
10	5.143	-	5.875	6.648	7.312	7.239	9.010	
15	4.413	-	5.144	5.917	6.581	6.508	8.279	
20	2.653	-	3.398	5.661	4.821	4.749	6.519	
25	2.511	-	3.256	5.520	4.680	4.607	6.378	
30	3.974	-	3.215	5.479	6.142	6.070	7.841	
40	2.406	-	3.151	-	4.574	4.502	6.273	
50	2.371	-	3.115	-	4.539	4.467	6.237	
65	1.672	2.024	3.096	-	3.841	3.768	5.539	
80	1.663	2.014	3.087	-	3.831	3.759	5.530	
100	1.656	2.008	3.080	-	3.825	3.752	5.523	





2.6 **Momenti d'inerzia** [Kg·cm²]
(riferiti all'albero veloce in entrata)

2.6 **Moments of inertia** [Kg·cm²]
(referred to input shaft)

2.6 **Trägheitsmoment** [Kg·cm²]
(bez. Antriebswelle)

X110	i_n	XA 	XC 			XF 			
			B5 - B14			B5			B5 - B14
			IEC 90	IEC 100-112	IEC 132	IEC 80	IEC 90	IEC 100-112	
7.5	16.247	-	17.980	20.038	20.584	20.535	20.711	22.704	
10	13.386	-	15.119	17.177	17.723	17.674	17.851	19.843	
15	11.343	-	13.076	15.134	15.679	15.631	15.807	17.799	
20	6.655	-	8.367	14.418	10.992	10.943	11.120	13.112	
25	6.257	-	7.969	14.020	10.594	10.545	10.722	12.714	
30	10.117	-	11.850	13.908	14.453	14.405	14.581	16.573	
40	5.965	-	7.677	-	10.302	10.254	10.430	12.422	
50	5.866	-	7.578	-	10.203	10.154	10.330	12.323	
65	3.792	5.592	7.510	-	8.128	8.080	8.256	10.248	
80	3.770	5.570	7.489	-	8.107	8.059	8.235	10.227	
100	3.755	5.555	7.474	-	8.092	8.044	8.220	10.212	

X130	i_n	XA 	XC 			XF 		
			B5 - B14			B5		
			IEC 90	IEC 100-112	IEC 132	IEC 90	IEC 100-112	IEC 132
7.5	42.80	-	40.70	42.78	48.92	49.22	50.01	
10	35.06	-	32.96	35.04	41.18	41.48	42.27	
15	29.53	-	27.43	29.51	35.66	35.96	36.74	
20	18.95	-	16.68	27.58	25.07	25.37	26.16	
25	17.80	-	15.52	26.42	23.92	24.22	25.00	
30	26.22	-	24.12	26.20	32.34	32.64	33.42	
40	17.09	-	14.81	25.71	23.21	23.51	24.29	
50	16.80	-	12.57	-	22.92	23.22	24.00	
65	12.53	10.46	14.35	-	18.66	18.96	19.74	
80	12.48	10.41	14.30	-	18.60	18.90	19.68	
100	12.44	10.37	14.26	-	18.56	18.86	19.65	

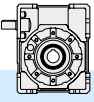

2.7 Dimensioni

2.7 Dimensions

2.7 Abmessungen

XA

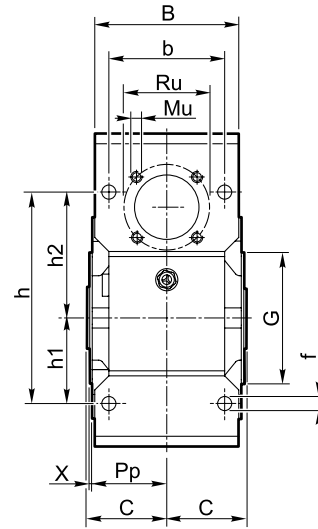
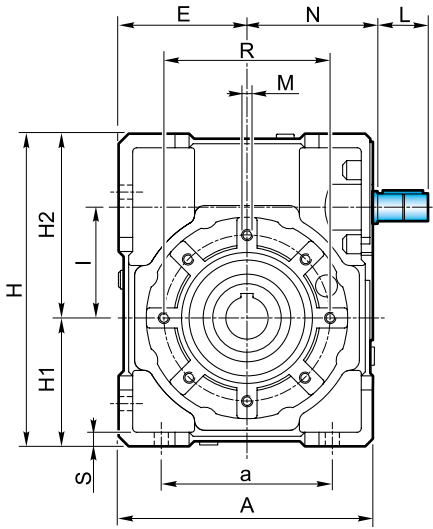

XF

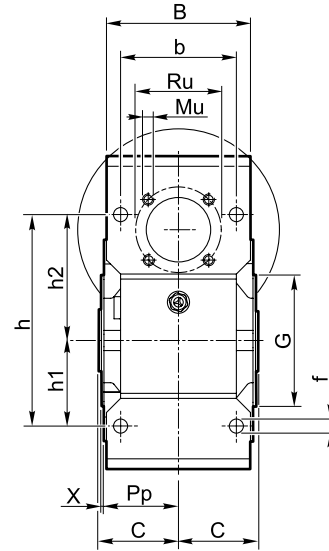
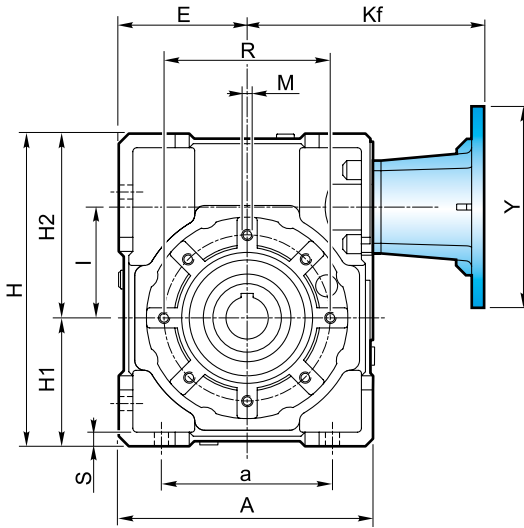

XC

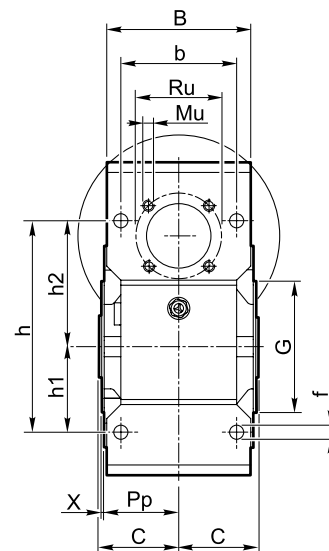
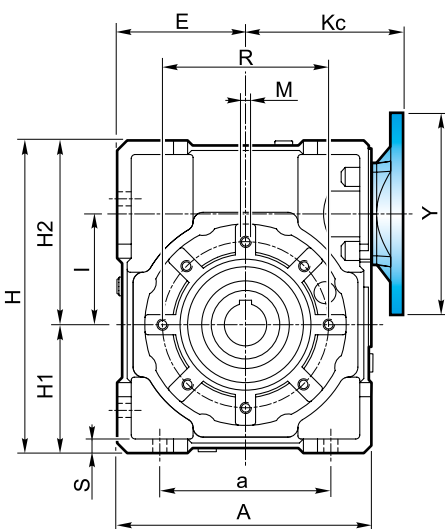

2.7 Dimensioni

2.7 Dimensions

2.7 Abmessungen

Flangia pendolare / Shaft-mounted flange / Aufsteckflansch

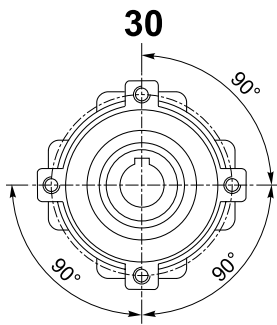

4 Fori / Holes / Bohrungen

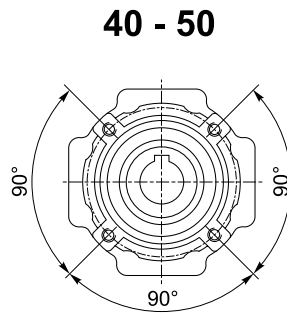

4 Fori / Holes / Bohrungen

63 - 75 - 90 - 110 - 130

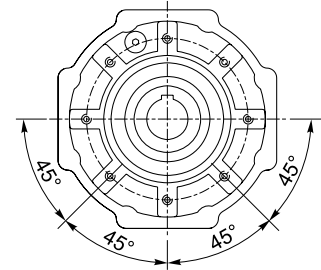

8 Fori / Holes / Bohrungen

Albero uscita cavo
Output hollow shaft
Abtriebshohlwelle

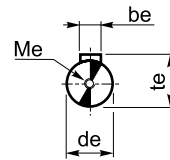
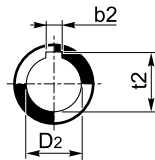

Albero entrata
Input shaft
Antriebswelle

X	A	a	B	b	b _e	b ₂	C	d _e j ₆	D ₂ H ₈	E	f	G h ₈	H	H ₁	H ₂	h	h ₁	h ₂		
30	80	54	56	44	3	5	—	31.5	9	14	—	40	6.5	55	97	40	57	71	27	44
40	105	70	71	60	4	6	6	39	11	18	19	50	6.5	60	125	50	75	90	35	55
50	125	80	85	70	5	8	8	46	14	25	24	60	8.5	70	150	60	90	104	40	64
63	147	100	103	85	6	8	—	56	19	25	—	72	9	80	182	72	110	130	50	80
75	176	120	112	90	8	8	8	60	24	28	30	86	11	95	219.5	86	133.5	153	60	93
90	203	140	130	100	8	10	—	70	24	35	—	103	13	110	248.5	103	145.5	172	70	102
110	252.5	170	143	115	8	12	—	77.5	28	42	—	127.5	14	130	310.5	127.5	183	210	85	125
130	292.5	200	155	120	10	14	14	85	38	45	48	147.5	15	180	355	147.5	207.5	240	100	140

X	I	K _c	K _f	L	M	M _e	M _u	N	P _p	R	Ru	S	t _e	t ₂	X	
30	31.5	57	vedi pag. see page siehe S. 34	15	M6x8	M4x10	M5x7.5	44.5	29	65	35.4	5.5	10.2	16.3	—	1.5
40	40	75		20	M6x10	M4x12	M5x10	57.5	36.5	75	42.4	6	12.5	20.8	21.8	1.5
50	50	82		25	M8x10	M5x13	M6x10	67.5	43.5	85	53.7	7	16	28.3	27.3	1.5
63	63	95		30	M8x14	M8x20	M6x12	77.5	53	95	60.8	8	21.5	28.3	—	2
75	75	112		40	M8x14	M8x20	M8x12	95	57	115	70.7	10	27	31.3	33.3	2
90	90	122		40	M10x18	M8x20	M8x14	105	67	130	70.7	12	27	38.3	—	2
110	110	153		50	M10x18	M8x20	M10x18	130	74	165	85.0	14	31	45.3	—	2.5
130	130	173		70	M12x20	M10x25	M10x16	152	81	215	104	15	41	48.8	51.8	3

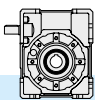

2.7 Dimensioni

2.7 Dimensions

2.7 Abmessungen

Flangia uscita / Output flange / Abtriebsflansch

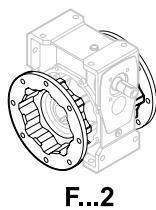
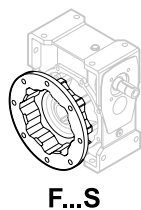
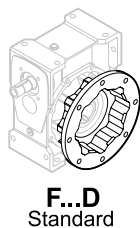
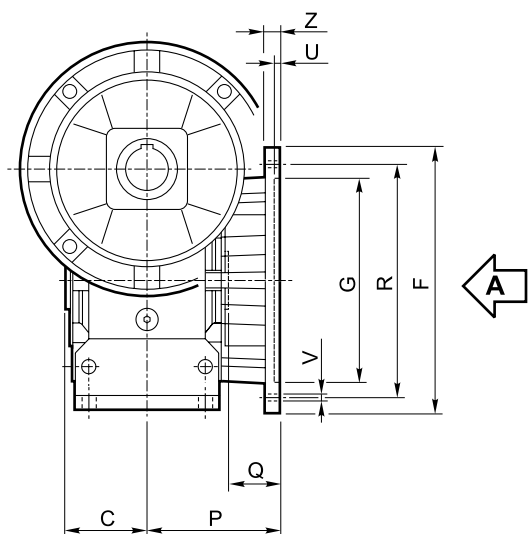

Vista da A / View from A / Ansicht von A

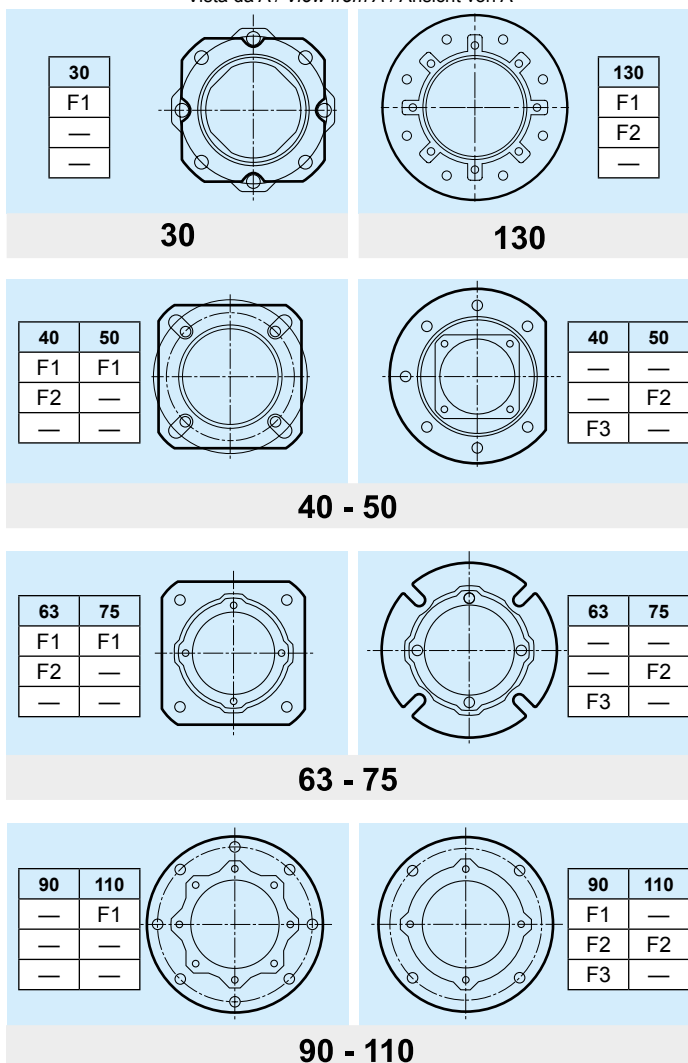

Tipo Type Typ	C	F		G H8	P	Q	R	U	V			Z	
													Ø
30	31.5		66	50	54.5	23	68	4	n° 4		6.5	6	
													F1
													F2
40	39		85	60	67	28	75-90	4	n° 4		9	8	
													F1
													F2
50	46		94	70	90	44	85-100	5	n° 4		11	10	
													F1
													F2
63	56		142	115	82	26	150	5	n° 4		11	11	
													F1
													F2
75	60		160	130	111	51	165	5	n° 4		13	12	
													F1
													F2
90	70		200	152	111	41	175	5	n° 4		13	12	
													F1
													F2
110	77.5		260	170	131	53.5	230	6	n° 4		13	15	
													F1
													F2
130	85		320	180	140	55	255	7	n° 8 *		16	16	
													F1
													F2

* Foratura ruotata di 22.5°

* Drilling turned of 22.5°

* Durchbohrung 22.5° versetzt



2.7 Dimensioni

2.7 Dimensions

2.7 Abmessungen

Flangia entrata / Input flange / Antriebsflansch

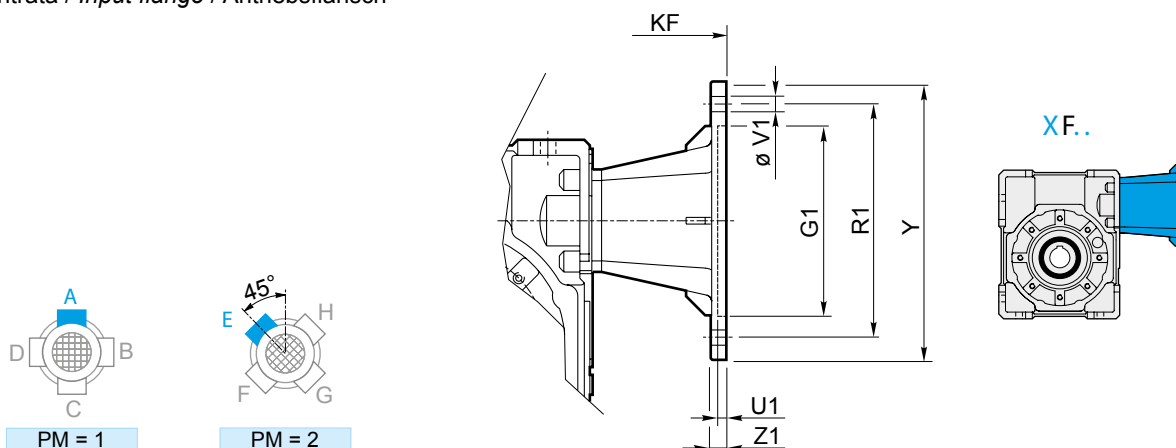

XF	IEC	PM		G ₁	K _F	V ₁						Y	Z ₁
		1	2			R ₁	U ₁	∅					
30	56 B5	•	•	80	82.5	100	3.5	7			8	120	8
	56 B14		•	50	82.5	65	3.5	6			4	80	8
	63 B5	•	•	95	85.5	115	4	9			8	140	10
	63 B14	•	•	60	85.5	75	3.5	6			8	90	8
40	56 B5	•	•	80	101.5	100	3.5	7			8	120	8
	63 B5	•	•	95	104.5	115	4	9			8	140	10
	63 B14	•	•	60	104.5	75	3.5	6			8	90	8
	71 B5	•	•	110	111.5	130	4.5	9			8	160	10
	71 B14	•	•	70	111.5	85	4	7			8	105	10
50	63 B5	•	•	95	119.5	115	4	9			8	140	10
	71 B5	•	•	110	126.5	130	4.5	9			8	160	10
	71 B14		•	70	126.5	85	3.5	7			4	105	10
	80 B5	•	•	130	136.5	165	4.5	11			8	200	10
	80 B14	•	•	80	136.5	100	4	7			8	120	10
63	71 B5	•	•	110	141.5	130	4.5	9			8	160	10
	80/90 B5	•	•	130	161.5	165	4.5	11			8	200	10
	80 B14	•	•	80	151.5	100	4	7			8	120	10
	90 B14	•	•	95	161.5	115	4	9			8	140	10
75	80/90 B5	•	•	130	190	165	4.5	11			8	200	10
	90 B14		•	95	190	115	4	9			4	140	10
	100/112 B5	•	•	180	200	215	5	14			8	250	14
	100/112 B14	•	•	110	200	130	4.5	9			8	160	10
90	80/90 B5	•	•	130	200	165	4.5	11			8	200	10
	90 B14		•	95	200	115	4	9			4	140	10
	100/112 B5	•	•	180	210	215	5	14			8	250	14
	100/112 B14	•	•	110	210	130	4.5	9			8	160	10
110	80/90 B5	•		130	235	165	4.5	11	4			200	12
	100/112 B5	•		180	245	215	5	14	4			250	14
	132 B5	•		230	266	265	5	14	4			300	16
	132 B14	•		130	266	165	4.5	11	4			200	12
130	90 B5	•		130	281	165	4.5	M10	4			200	12
	100/112 B5	•		180	289	215	5	13	4			250	16
	132 B5	•		230	310	265	5	13	4			300	20

N.B.: Il montaggio STD di P_M=2 solo quando non è possibile il montaggio STD di P_M=1.

N.B.: STD mounting of P_M=2 only if STD mounting of P_M=1 is not possible.

ANMERKUNG: STD Montage von P_M=2 nur wenn STD Montage von P_M=1 unmöglich ist.

2.8 Entrata supplementare (vite bisporgente)

2.8 Additional input (double extended shaft)

2.8 Zusatzantrieb (beidseitige Welle)

S.e.A.

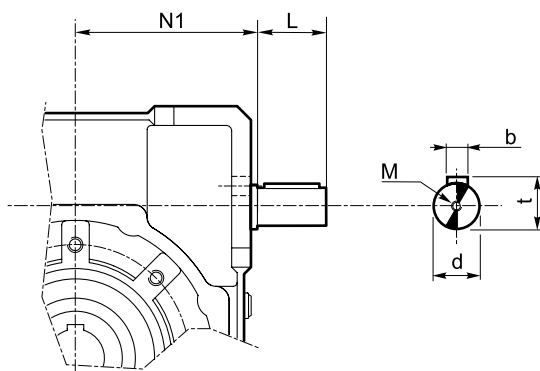

X	d j6	L	M	N1	b	t
30	9	15	M4x10	42.5	3	10.2
40	11	20	M4x12	52.5	4	12.5
50	14	25	M5x13	62.5	5	16
63	19	30	M8x20	74.5	6	21.5
75	24	40	M8x20	91	8	27
90	24	40	M8x20	108	8	27
110	28	50	M8x20	132.5	8	31
130	38	70	M10x25	152	10	41

2.9 Limitatore di coppia cavo passante

2.9 Torque limiter with through hollow shaft

2.9 Drehmomentbegrenzer mit durchgehender Hohlwelle

Il limitatore di coppia viene consigliato in tutte quelle applicazioni che richiedono una limitazione sulla coppia trasmissibile per proteggere l'impianto e/o preservare il riduttore evitando sovraccarichi o urti indesiderati quanto inaspettati.

È un dispositivo con albero dotato di cavo passante, con funzionamento a frizione, ed è integrato al riduttore, presentando un ingombro limitato.

Concepito per lavorare a bagno d'olio, il dispositivo risulta affidabile nel tempo ed è esente da usura se non viene mantenuto in condizioni prolungate di slittamento (condizione che si verifica quando la coppia presenta valori superiori a quelli di taratura).

La taratura è facilmente regolabile dall'esterno attraverso il serraggio di una ghiera autobloccante che porta a compressione le 4 molle a tazza disposte tra loro in serie.

Il dispositivo non consente:

- l'impiego di cuscinetti a rulli conici in uscita
- funzionamento prolungato in condizioni di slittamento.

Nella tabella seguente vengono riportati i valori delle coppie di slittamento M_{2S} in funzione del n° di giri della ghiera.

I valori di taratura presentano una tolleranza del $\pm 10\%$ e si riferiscono ad una condizione statica.

In condizioni dinamiche è da notare che la coppia di slittamento assume valori diversi a seconda del tipo e/o modalità in cui si verifica il sovraccarico: con valori maggiori in caso di carico uniformemente crescente rispetto a valori più contenuti in seguito al verificarsi di picchi improvvisi di carico.

NOTA: quando si supera il valore di taratura si ha slittamento.

Il coefficiente di attrito tra le superfici di contatto da statico diventa dinamico e la coppia trasmessa cala del 30% circa.

È quindi opportuno prevedere uno stop per poter ripartire al valore di taratura iniziale.

The use of a torque limiter is advised when the application requires the limitation of the transmissible torque to safeguard the plant and/or to prevent from unexpected and undesired overloads or shocks which might damage the gearbox.

The torque limiter is a device equipped with through hollow shaft and a friction clutch. It is integrated with the gearbox, therefore the space requirement is limited.

Designed to work in oil bath, the device is reliable over time and is not subject to wear unless kept under conditions of prolonged slipping (it occurs when the torque values are higher than the calibration values).

Calibration can be easily adjusted from outside by tightening the self-locking ring nut which causes the compression of the 4 Belleville washers arranged in series.

The device does not go together with:

- the use of tapered roller bearings at output
- Prolonged operation under slipping conditions.

The following table shows the values of M_{2S} slipping torques depending on the number of revolutions of the ring nut.

Calibration values feature a $\pm 10\%$ tolerance and refer to static conditions.

Under dynamic conditions, the values of the slipping torque differ depending to the type of overload: the values are higher if the load increase is uniform, the values are lower if sudden load peaks occur.

NOTE: *Slipping occurs when the setting values are exceeded.*

The friction coefficient between the contact surfaces from static becomes dynamic and the transmitted torque is approx. 30% lower.

It is advisable to have a stop first in order to have a restart based on the initial setting value.

Die Anwendung eines Drehmomentbegrenzers wird empfohlen, um die Anlage und/oder das Getriebe gegen ungewünschte und unerwartete Überbelastungen oder Stöße zu schützen.

Der Begrenzer verfügt über eine Welle mit durchgehende Hohlwelle und eine Kupplung. Er ist in dem Getriebe integriert, d.h. der Raumbedarf ist klein.

Der Drehmomentbegrenzer wurde für Betrieb in einem Ölbad entworfen. Er ist zuverlässig über Zeit und verschleissfest (außer wenn Rutschen für lange Zeit besteht: das passiert, wenn das Drehmoment höher als der Eichwert ist).

Die Einstellung darf mühelos von außen durch das Anziehen einer selbstsperrenden Mutter ausgeführt werden.

Das Anziehen verursacht die Zusammendrückung der 4 wechelsinniggeschichteten Tellerfeder.

Der Begrenzer sieht das folgende nicht vor:

- die Verwendung von Kegelrollenlager am Abtrieb
- Längerer Rutschbetrieb.

Die nachstehende Tabelle zeigt die Werte der Rutschmomente M_{2S} abhängig von der Zahl der Umdrehungen der Mutter.

Die Eichwerte weisen $\pm 10\%$ Toleranz auf und beziehen sich auf statische Bedingungen.

Unter dynamischen Bedingungen hat das Rutschmoment verschiedene Werte je nach Art der Überbelastung. Die Werte sind höher, wenn die Belastung gleichmäßig zunimmt; sie sind niedriger im Falle von plötzlichen Belastungsspitzen.

BEMERKUNG: Rutschen tritt auf, wenn die eingestellten Werte überschritten werden. Der Reibungskoeffizient zwischen den Berührungsfleichen wird dynamisch anstatt statisch und das übertragene Drehmoment sinkt um ca. 30%.

Es ist daher ratsam, vor dem erneuten Anfahren anzuhalten, um die ursprünglichen Drehmomentwerte zu erreichen.



E' importante notare che la coppia di slittamento non resta sempre la medesima durante tutta la vita del limitatore.

Tende infatti a diminuire in rapporto al numero e alla durata degli slittamenti che, rodando le superfici di contatto, ne aumentano il rendimento.

È quindi opportuno verificare periodicamente, soprattutto durante la fase di rodaggio, la taratura del dispositivo.

Là dove sia richiesto un errore più contenuto nella taratura, è necessario testare la coppia trasmissibile sull' impianto.

Il dispositivo viene consegnato tarato alla coppia riportata a catalogo T_{2M} salvo diversa indicazione espressa in fase di ordinazione.

It is important to note that the slipping torque is not the same for the entire life of the torque limiter. It usually decreases in connection with the number and the duration of slippings, this is due to the surface of the torque limiter becoming more engaged, therefore increasing the efficiency.

For this reason it is advisable to check the calibration of the device at regular intervals, specially during the running-in period. Should a smaller calibration error be required, it is necessary to test the transmissible torque on the plant.

The torque limiter is supplied already calibrated at the torque value T_{2M} , unless otherwise specified in the order.

Es ist wichtig zu beachten, dass das Rutschmoment der Rutschkupplung über die gesamte Lebensdauer nicht konstant bleibt, sondern üblicherweise in Verbindung mit längeren Rutschzyklen aufgrund der eingelaufenen Berührungsflächen abnimmt.

Deswegen ist es ratsam, die Einstellung der Vorrichtung besonders während der Einlaufzeit in regelmäßigen Zeitabständen zu prüfen.

Wenn der Drehmomentbegrenzer geliefert wird, ist dieser schon auf dem im Katalog unter T_{2M} angegebenen Wert eingestellt, außer wenn es in der Bestellung anders angegeben wird.

X	N°. giri della ghiera di regolazione / N°. revolutions of ring nut / Nr. Umdrehungen der Mutter															
	3/4	1	1 1/4	1 1/2	1 3/4	2	2 1/4	2 1/2	2 3/4	3	3 1/4	3 1/2	3 3/4	4	4 1/4	4 1/2
	M_{2S} [Nm]															
30		15	18	22	27	32										
40	23	30	35	40	45	50	60									
50		45	60	70	80	90	100	110								
63			80	90	100	110	120	130	140	150	160	170	180	190	200	
75		140	160	180	200	220	240	260	280	300						
90						230	280	310	330	350	380	410	435	460	490	510
110		420	500	560	670	730	810	910								
130																

Disposizione delle molle
Washers' arrangement
Lage der Feder

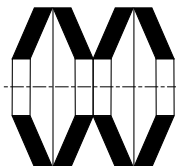

IN SERIE (min. coppia, max. sensibilità)
SERIES (min. torque, max sensitivity)
SERIE (min. Moment, max. Empfindlichkeit)

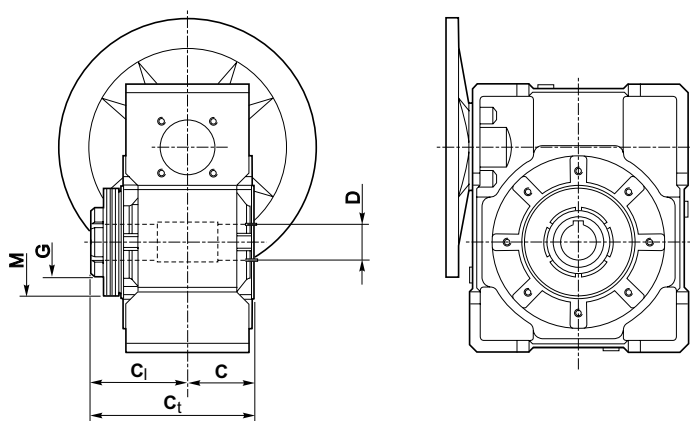

X	C	C _i	C _t	D _{H8}	M	G
30	31.5	55.5	87	14	50x25.4x1.25	M25x1.5
40	39	65	104	18 (19)	56x30.5x1.5	M30x1.5
50	46	76	122	25 (24)	63x40.5x1.8	M40x1.5
63	56	91	147	25	71x40.5x2	M40x1.5
75	60	100	160	28 (30)	90x50.5x2.5	M50x1.5
90	70	109	179	35 (32)	100x51x2.7	M50x1.5
110	77.5	127.5	205	42	125x61x4	M60x2.0
130						

() A richiesta / On request / Auf Anfrage

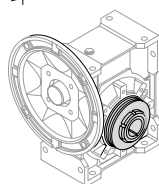

LD

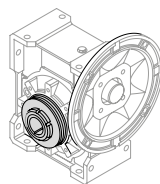

LS

Nella versione con limitatore non è prevista la fornitura degli alberi lenti.

The version with torque limiter is supplied without output shafts.

Die Version mit Drehmomentbegrenzer wird ohne Abtriebswellen geliefert.

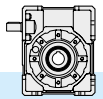

2.10 Accessori

2.10 Accessories

2.10 Accessories

Albero lento

Output shaft

Abtriebswelle

Albero lento semplice
Single output shaft
Standard Abtriebswelle

Albero lento doppio
Double output shaft
Doppelte Abtriebswelle

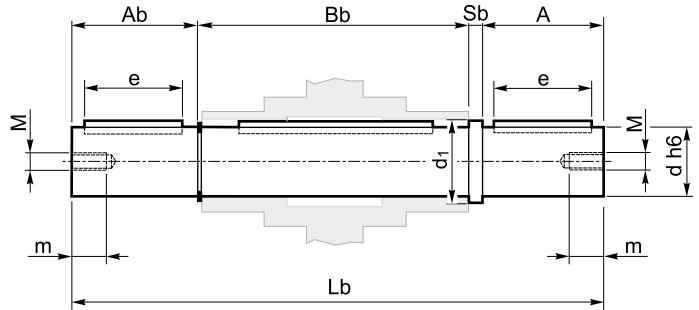
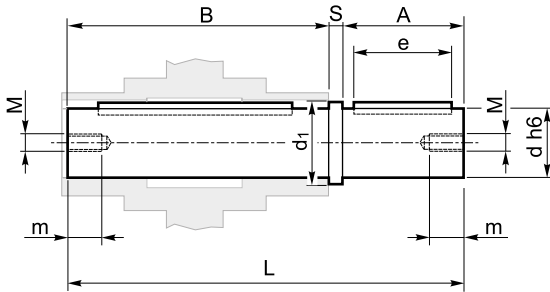

X	A	B	d _{h6}		d ₁	e	L	M	m	S
30	30	62	14		18.5	20	94.5	M6	16	2.5
40	40	77	18	19	23.5	30	120	M6	16	3
50	50	90	25	24	31.5	40	143.5	M8	22	3.5
63	50	111	25		31.5	40	165	M8	22	4
75	60	119	28	30	34.5	50	183	M8	22	4
90	80	139	35		41.5	60	224	M10	28	5
110	80	154.5	42		49.5	60	242.5	M10	28	8
130	80	168	45		54.5	70	253	M16	36	5

A	A _b	B _b	d _{h6}	d ₁	e	L _b	S _b
30	29	64	14	18.5	20	126	2.5
40	39	79	18	23.5	30	161	3
50	49	93	25	31.5	40	195.5	3.5
50	49	113	25	31.5	40	216	4
60	59	121	28	34.5	50	244	4
80	78.5	141.5	35	41.5	60	305	5
80	77.5	157	42	49.5	60	322.5	8
80	78	172	45	54.5	70	335	5

Braccio di reazione

Torque arm

Drehmomentstütze

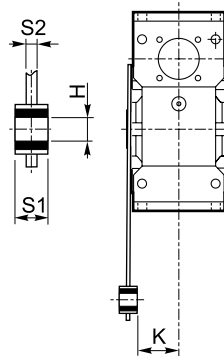
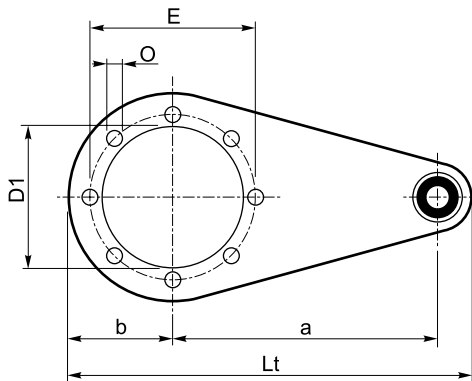

X	a	b	D ₁	E	H	K	L _t	O	S ₁	S ₂
30	85	37.5	55	65	8	24	141.5	7	14	4
40	100	45	60	75	10	31.5	167	7	14	4
50	100	50	70	85	10	39	172	9	14	5
63	150	55	80	95	10	49	227	9	14	6
75	200	70	95	115	20	47.5	302	9	25	6
90	200	80	110	130	20	57.5	312	11	25	6
110	250	100	130	165	25	62	390	11	30	6
130	250	125	180	215	25	69	415	13	30	6

Kit di protezione:

Protection Kit:

Schutzvorrichtung

Albero cavo / Hollow shaft / Hohlwelle

Limitatore di coppia / Torque limiter / Drehmomentbegrenzer

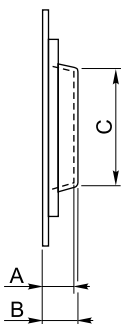

X	A	B	C
30	12	13	39
40	14	15.5	44.5
50	15	16.5	54
63	17	19	60
75	17.5	20	70
90	21.5	24	80
110	22	25	96
130	22	25	130

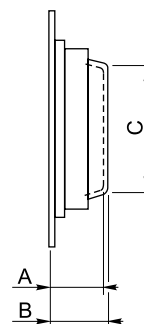

X	A	B	C
30	36	37	36
40	40	41.5	44
50	47	48.5	53
63	52	54	55
75	58	60	68
90	60.5	63	70
110	72	75	85
130			

Opzioni disponibili:

Available options:

Auf Anfrage ist folgendes Zubehör erhältlich:

Cuscinetti a rulli conici corona

Tapered roller bearing on wormgear

Kegelrollenlager auf Schneckenrad



XA - XF

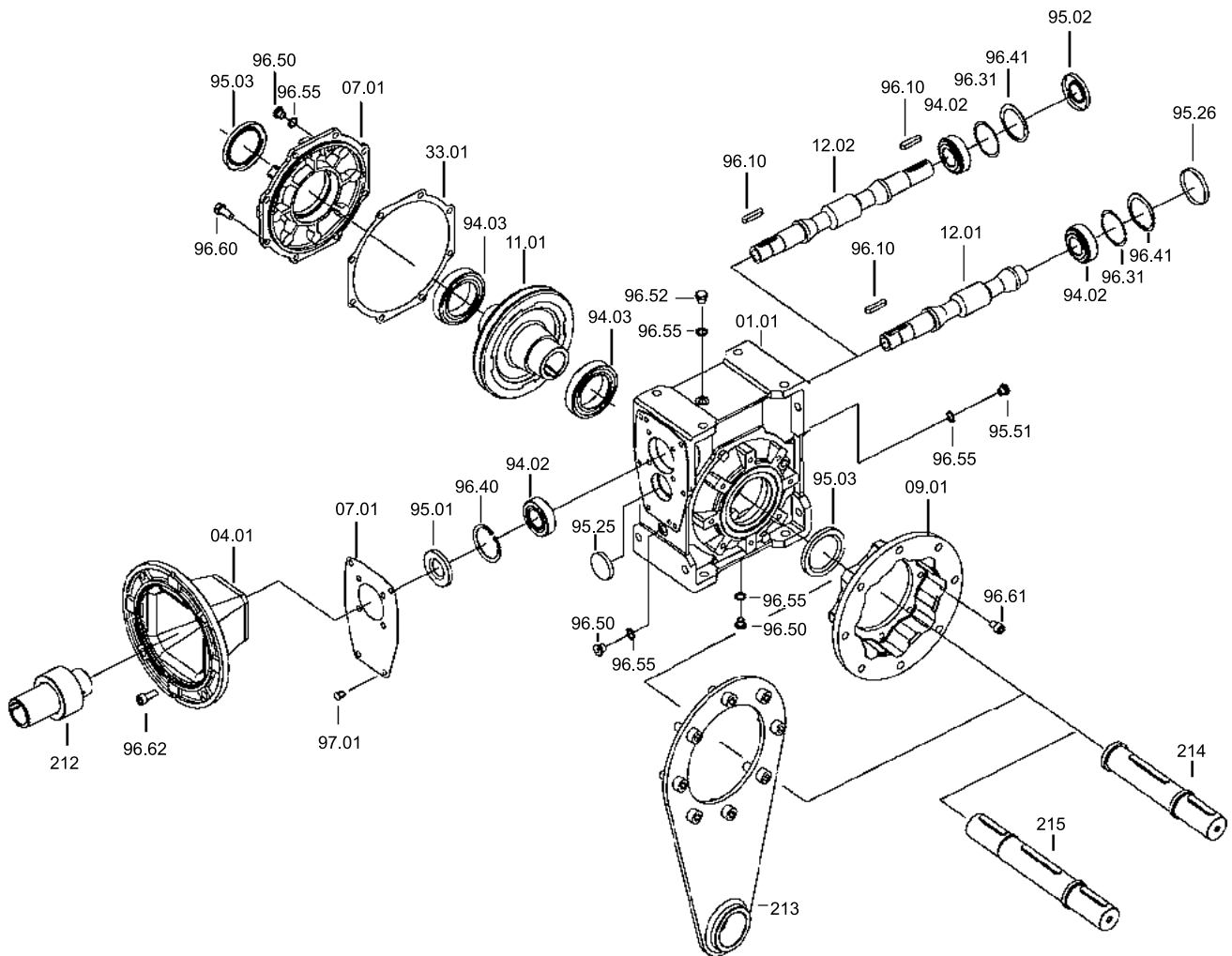

X	Cuscinetti / Bearings / Lager			Anelli di tenuta / Oilseals Öldichtungen			Cappellotto / Closed oil seal Geschlossene Öldichtung	
	94.02	94.03		95.01	95.02	95.03	95.25	95.26
30	6000 10x26x8	6005 25x47x12	*32005 25x47x15	10/26/5.5	10/26/7	25/40/7	—	ø 6x7
40	6201 12x32x10	6006 30x55x13	*32006 30x55x17	12/32/7	12/32/7	30/47/7	—	ø 32x7
50	6203 17x40x12	6008 40x68x15	*32008 40x68x19	17/40/7	17/40/7	40/62/8	—	ø 40x7
63	30204 20x47x15.25	6008 40x68x15	*32008 40x68x19	20/47/7	20/47/7	40/62/8	—	ø 47x7
75	30205 25x52x16.25	6010 50x80x16	*32010 50x80x20	25/52/7	25/52/7	50/72/8	—	ø 52x7
90	32205 25x52x19.25	6010 50x80x16	*32010 50x80x20	25/52/7	25/52/7	50/72/8	ø 35x5	ø 52x7
110	32206B 30x62x21.25	6012 60x95x18	*32012 60x95x23	30/62/7	30/62/7	60/85/8	ø 47x7	ø 62x7
130	33208 40x80x32	6015 75x115x20	*32015 75x115x25	40/80/10	40/80/10	75/100/10	ø 52x7	ø 80x10

* Cuscinetti a rulli conici a richiesta - Tapered roller bearings on request - Auf Wunsch Kegelrollenlager



XC

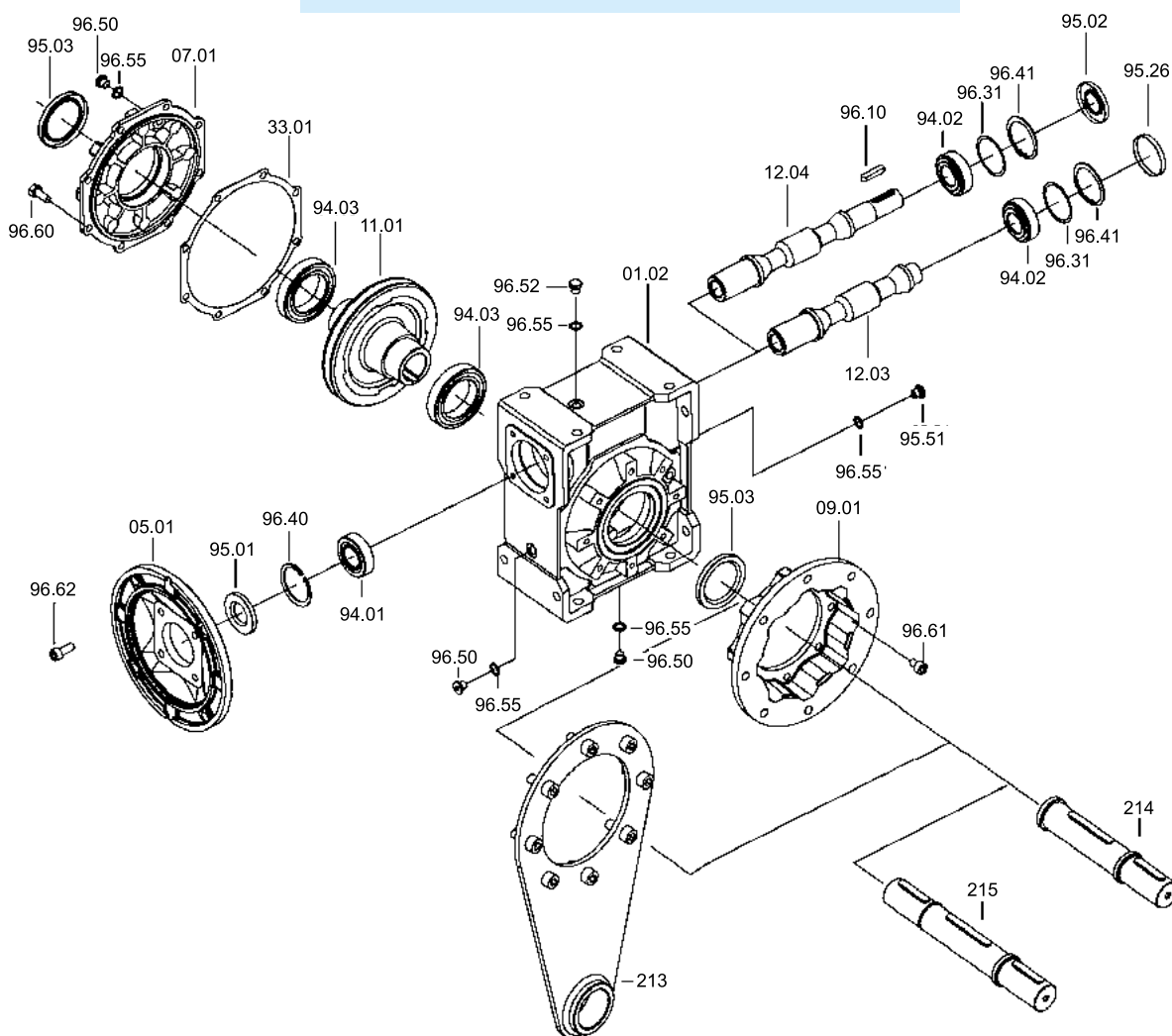

X	IEC	Cuscinetti / Bearings / Lager				Anelli di tenuta / Oilseals Öldichtungen			Cappello / Closed oil seal Geschlossene Öldichtung
		94.01	94.02	94.03		95.01	95.02	95.03	95.26
30	56	61804 (20x32x7)	6000 10x26x8	6005 25x47x12	*32005 25x47x15	20/32/5	10/26/7	25/40/7	ø 26x7
	63	61804 (20x32x7)		20/32/5					
40	56	6303 (17x47x14)	6201 12x32x10	6006 30x55x13	*32006 30x55x17	17/47/7	12/32/7	30/47/7	ø 32x7
	63	6204 (20x47x14)		20/47/7					
	71	6005 (25x47x12)		25/47/7					
50	63	6204 (20x47x14)	6203 17x40x12	6008 40x68x15	*32008 40x68x19	20/47/7	17/40/7	40/62/8	ø 40x7
	71	6005 (25x47x12)		25/47/7					
	80	6006 (30x55x13)		30/55/7					
63	71	30305 (25x62x18.25)	30204 20x47x15.25	6008 40x68x15	*32008 40x68x19	25/62/7	20/47/7	40/62/8	ø 47x7
	80	30206 (30x62x17.25)		30/62/7					
	90	32007 (35x62x18)		35/62/7					
75	80	30206 (30x62x17.25)	30205 25x52x16.25	6010 50x80x16	*32010 50x80x20	30/62/7	25/52/7	50/72/8	ø 52x7
	90	32007 (35x62x18)		35/62/7					
	100/112	32008 (40x68x19)		40/68/10					
90	80	30206 (30x62x17.25)	32205B 25x52x19.25	6010 50x80x16	*32010 50x80x20	30/62/7	25/52/7	50/72/8	ø 52x7
	90	32007 (35x62x18)		35/62/7					
	100/112	32008 (40x68x19)		40/68/10					
110	90	30208 (40x80x19.75)	32206B 30x62x21.25	6012 60x95x18	*32012 60x95x23	40/80/10	30/62/7	60/85/8	ø 62x7
	100/112	30208 (40x80x19.75)		40/80/10					
	132	32010 (50x80x20)		50/80/10					
130	90	30208 (40x80x19.75)	33208 40x80x32	6015 75x115x20	*32015 75x115x25	40/80/10	40/80/10	75/100/10	ø 80x10
	100/112	30208 (40x80x19.75)		40/80/10					
	132	32010 (50x80x20)		50/80/10					

* Cuscinetti a rulli conici a richiesta - Tapered roller bearings on request - Auf Wunsch Kegelrollenlager

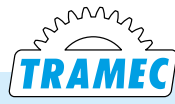
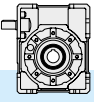

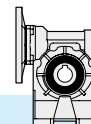

3.0	RIDUTTORE A VITE SENZA FINE SERIE K	K WORM GEARBOXES	SCHNECKENGETRIEBE K	
3.1	Caratteristiche	<i>Characteristics</i>	Merkmale	42
3.2	Designazione	<i>Designation</i>	Bezeichnung	43
3.3	Lubrificazione e posizioni di montaggio	<i>Lubrication and mounting position</i>	Schmierung und Einbaulage	43
3.4	Posizione morsettiera	<i>Terminal board position</i>	Lage des Klemmenbrett	43
3.5	Dati tecnici	<i>Technical data</i>	Technische Daten	43
3.6	Momenti d'inerzia	<i>Moments of inertia</i>	Trägheitsmoment	54
3.7	Dimensioni	<i>Dimensions</i>	Abmessungen	56
3.8	Entrata supplementare	<i>Additional input</i>	Zusatzantrieb	59
3.9	Limitatore di coppia cavo passante	<i>Torque limiter with through hollow shaft</i>	Drehmomentbegrenzer mit durchgehender Hohlwelle	59
3.10	Accessori	<i>Accessories</i>	Zubehör	61
3.11	Lista parti di ricambio	<i>Spare parts list</i>	Ersatzteilliste	62

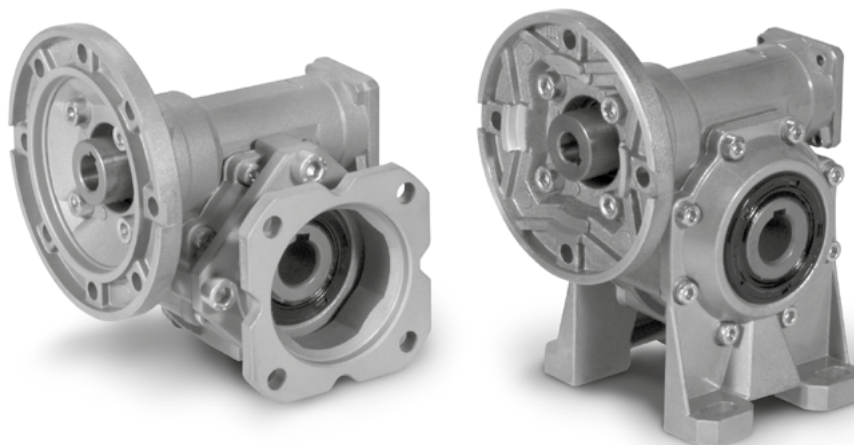

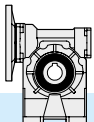

3.1 Caratteristiche

- I riduttori della serie a vite senza fine KC si presentano estremamente leggeri grazie alla forma compatta della carcassa in ghisa nelle grandezze 90, 110 e 130, in alluminio pressofuso per le grandezze 30, 40, 50, 63 e 75.
- La serie presenta una svariata possibilità di versioni, con e senza piedi, che la rendono più versatile nell'impiego in ogni tipologia di applicazione.
- La serie K è disponibile esclusivamente nella versione predisposta per attacco motore (PAM) e non con albero entrata maschio.
- La vite senza fine è in acciaio legato cementato-temprato ed è rettificata.
- La corona ha il mozzo in ghisa con riporto di fusione dell'anello in bronzo.
- Le carcasse in ghisa sono verniciate BLU RAL5010 mentre quelle in alluminio sono sabbiate.
- Viene fornito l'albero uscita cavo di serie ed esiste un'ampia disponibilità di accessori: seconda entrata, cuscinetti conici sulla corona, flangia uscita, albero lento con 1 o 2 sporgenze, limitatore di coppia con cavo passante, braccio di reazione, kit protezione albero cavo, kit protezione limitatore di coppia.

3.1 Characteristics

- *The KC worm gearboxes are extremely light thanks to the compact shape of the housing, which is in cast iron for sizes 90, 110 and 130, in die-cast aluminium for sizes 30, 40, 50, 63 and 75.*
- *This series features a wide range of versions, with and without feet, which makes it extremely versatile for utilization in various applications.*
- *The K series is available for motor mounting version (PAM) only and not with the male input shaft.*
- *The worm shaft is in case-and quench-hardened alloy steel and ground.*
- *The worm wheel has a cast-iron hub with inserted cast bronze ring.*
- *The cast-iron housings are painted BLUE RAL5010 whereas the aluminium housings are sandblasted.*
- *The hollow output shaft is supplied as standard. A broad range of accessories is available: second input, tapered roller bearings on the worm wheel, output flange, single or double-extended output shaft, torque limiter with through hollow shaft, torque arm, hollow shaft protection kit, torque limiter protection kit.*

3.1 Merkmale

- Die Schneckengetriebe der Serie KC sind äußerst leicht dank der kompakten Form des Gehäuses. Das Gehäuse ist aus Gusseisen für Größen 90, 110 und 130, aus Druckgussaluminium für Größen 30, 40, 50, 63 und 75.
- Diese Serie ist in vielen Ausführungen, mit und ohne Füße erhältlich, was eine vielseitige Anwendbarkeit in unterschiedlichsten Applikationen ermöglicht.
- Die Serie K ist nur mit Motoranbau Version (IEC) und nicht mit einer Antriebswelle verfügbar.
- Die Schneckenwelle ist aus einsatzgehärtetem / abgeschrecktem und daraufhin geschliffenem Legierungsstahl.
- Das Schneckenrad besteht aus einer Nabe aus Gusseisen und einem aufgeschleuderten Gussbronze-Ring.
- Gehäuse aus Gusseisen werden mit BLAU RAL5010 lackiert, die Gehäuse aus Aluminium werden sandgestrahlt.
- Die Hohlwelle gehört zur serienmäßigen Ausstattung. Eine breite Auswahl an Zubehör ist erhältlich: zweiter Antrieb, Kegellager auf das Schneckenrad, Abtriebsflansch, Standard oder doppelseitig herausragende Abtriebswelle, Drehmomentbegrenzer mit durchgehender Hohlwelle, Drehmomentstütze, Schutzvorrichtung für Hohlwelle, Schutzvorrichtung für Drehmomentbegrenzer.

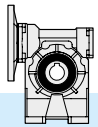

3.2 Designazione

3.2 Designation

3.2 Bezeichnung

Riduttore Gearbox Getriebe	Tipo entrata Input type Antriebsart	Grandezza Size Größe	Versione Version Ausführung	Rapporto rid. Ratio Untersetzung	Predispos. att. mot. Motor coupling Motoranschluss	Posizione di mont. Mounting position Einbaulage	Limitatore di coppia. Torque limiter Drehmomentbegrenzer	Seconda entrata Additional input Zusatzantrieb	Albero uscita Output shaft Abtriebswelle	Braccio di reazione Torque arm Drehmomentstütze
K	C	50	F1S	10	P.A.M	B3	LD	SeA	H	BR
Riduttore a vite senza fine Wormgearbox Schneckengetriebe		30 40 50 63 75 90 110 130	A1-A2 B1-B2 V1-V2 P F1S-F2S F3S F1D-F2D F3D	5 7.5 10 15 20 25 30 40 50 65 80 100	56 63 71 80 90 100 112 132	B3 B6 B7 B8 V5 V6	LS LD	SeA	H SD SS DD	BR

Versioni

Versions

Ausführungen

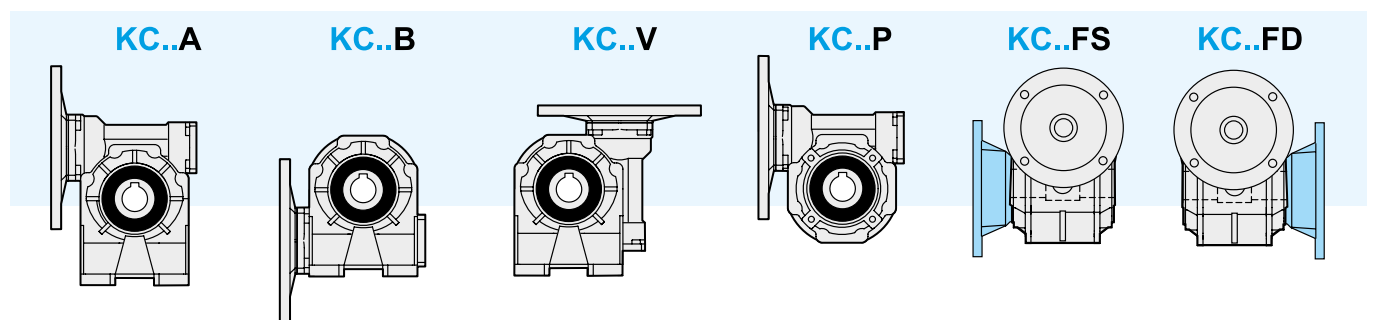

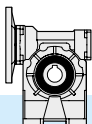

3.3 Lubrificazione

I riduttori a vite senza fine serie K, tranne la grandezza 130, sono forniti completi di lubrificante sintetico a base PAG con indice di viscosità ISO VG320. Si raccomanda di precisare sempre, in fase di ordine, la posizione di montaggio desiderata.

3.3 Lubrication

KC worm gearboxes, except for the size 130, are supplied with PAG synthetic lubricant featuring an ISO VG320 viscosity class. Mounting position always to be specified when ordering.

3.3 Schmierung

Schneckengetriebe der Serie KC, außer Größe 130, werden mit synthetischem Schmiermittel auf PAG Basis und Viskosität Index ISO VG320 geliefert. Im Auftrag bitte immer die gewünschte Einbaulage angeben.

Posizioni di montaggio

Mounting positions

Einbaulagen

F,P

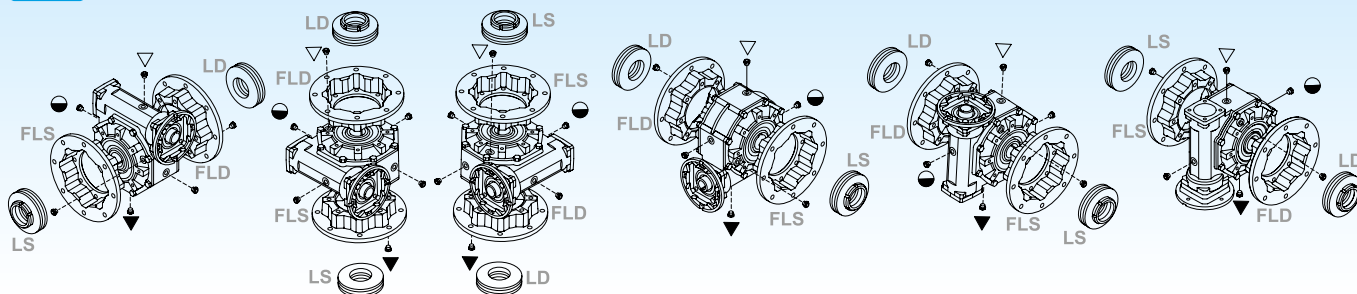

A

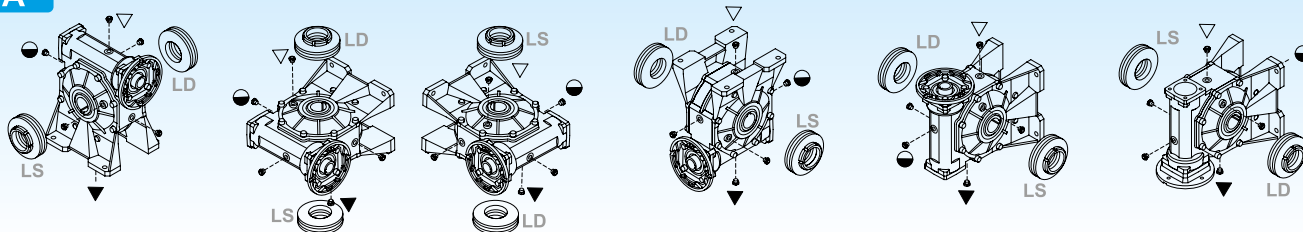

V

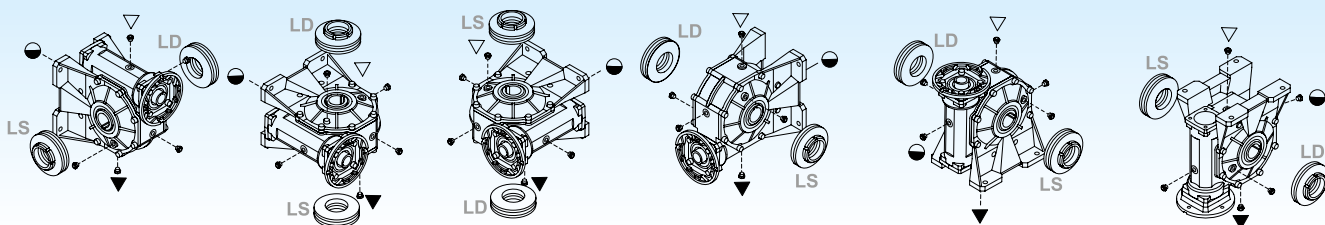

B

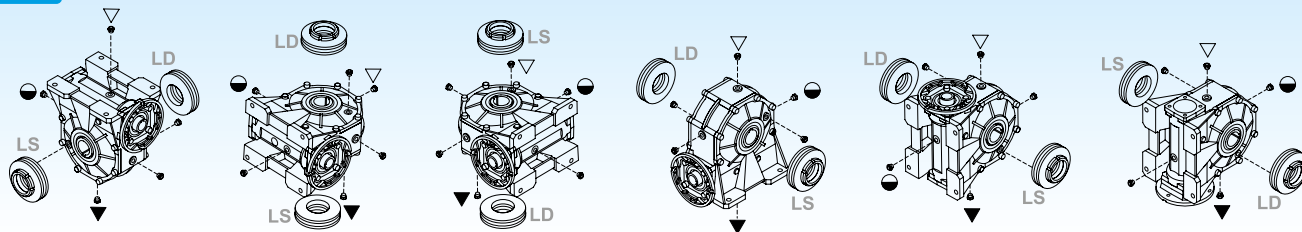

B3

B6

B7

B8

V5

V6

- ▽ Carico e sfiato / Filling and breather
Einfüll und Entlüftung
- Livello / Level / Ölstand
- ▼ Scarico / Drain / Ablass

Nei corpi in alluminio 30, 40, 50, 63, 75 è presente un solo tappo di riempimento olio.

Aluminium housings size 30, 40, 50, 63 and 75 have one filling plug only.

Gehäuse aus Aluminium Größe 30, 40, 50, 63 und 75 verfügen über nur eine Einfüllschraube.

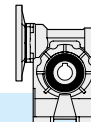

3.3 Lubrificazione

3.3 Lubrication

3.3 Schmierung

		Q.tà olio / Oil quantity / Schmiermittelmenge [lt]			
		Posizione di montaggio / Mounting position / Einbaulage			
		B3	B6 - B7	B8	V5 - V6
KC	30	0.015	0.030	0.015	
	40	0.040	0.060	0.040	
	50	0.080	0.120	0.080	
	63	0.160	0.220	0.160	
	75	0.260	0.340	0.260	
	90	1	0.8	0.8	1.3
	110	2	1.5	2	2
	130	3	2.6	2.1	2.8

3.4 Posizione morsettiera

3.4 Terminal board position

3.4 Lage der Klemmenkaste

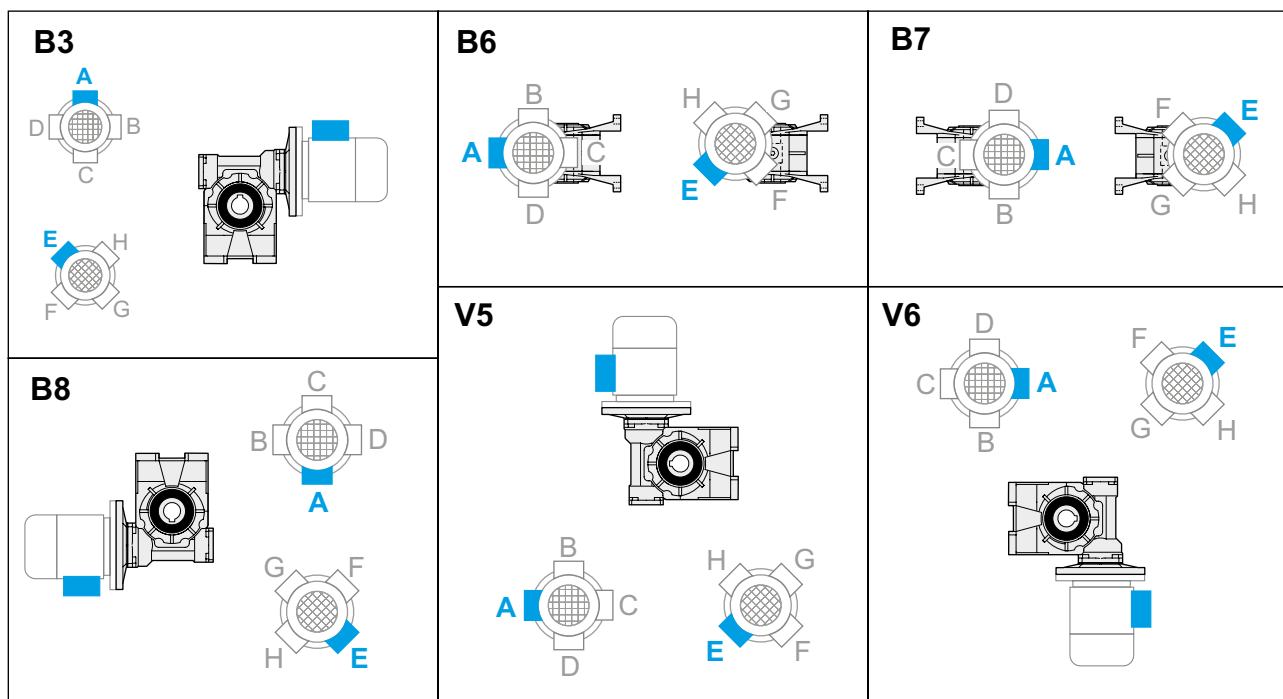

Specificare sempre in fase di ordinazione la posizione di montaggio e la forma costruttiva.
 Posizione morsettiera v. pag. 58
 (PM=1; PM=2)

Mounting position always to be specified when ordering.
Terminal board position see page 58
 (PM=1; PM=2)

Bei der Bestellung immer die gewünschte Montageposition und Bauform angeben.
 Lage der Klemmenkaste Seite 58
 (PM=1; PM=2)

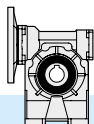

3.5 Dati tecnici

3.5 Technical data

3.5 Technische Daten

30	$n_1 = 2800$				KC				Input - IEC	
	i_n	n_2 [min ⁻¹]	Rd	P_{10}	T_2 [Nm]	P_1 [kW]	FS'	B5/B14		
	5	560	0.89	—	5.6	0.37	2.5	63	56	
7.5	373	0.86	8		0.37	2.0				
10	280	0.84	11		0.37	1.5				
15	187	0.81	15		0.37	1.1				
20	140	0.76	13		0.25	1.2				
25	112	0.74	16		0.25	1.0				
30	93	0.71	13		0.18	1.0				
40	70	0.65	16		0.18	1.0				
50	56	0.62	14		0.13	1.1				
65	43	0.57	17		0.13	1.0				
80	35	0.54	13		0.09	1.0				
100	28	0.52	16		0.09	0.8				



30	$n_1 = 1400$				KC				Input - IEC	
	i_n	n_2 [min ⁻¹]	Rd	P_{10}	T_2 [Nm]	P_1 [kW]	FS'	B5/B14		
	5	280	0.87	0.40	6.5	0.22	2.9	63	56	
7.5	187	0.84	0.40	9	0.22	2.2				
10	140	0.82	0.40	12	0.22	1.8				
15	93	0.77	0.30	17	0.22	1.3				
20	70	0.72	0.20	18	0.18	1.1				
25	56	0.69	0.20	21	0.18	1.0				
30	47	0.66	0.20	18	0.13	1.1				
40	35	0.59	0.20	21	0.13	1.0				
50	28	0.55	0.20	17	0.09	1.1				
65	22	0.51	0.10	20	0.09	1.0				
80	18	0.48	0.10	16	0.06	1.0				
100	14	0.45	0.10	18	0.06	0.8				



30	$n_1 = 900$				KC				Input - IEC	
	i_n	n_2 [min ⁻¹]	Rd	P_{10}	T_2 [Nm]	P_1 [kW]	FS'	B5/B14		
	5	180	0.85	—	5.9	0.13	3.9	63	56	
7.5	120	0.82	9		0.13	2.9				
10	90	0.80	11		0.13	2.3				
15	60	0.75	15		0.13	1.6				
20	45	0.69	19		0.13	1.2				
25	36	0.66	23		0.13	1.1				
30	30	0.63	18		0.09	1.2				
40	23	0.55	21		0.09	1.1				
50	18	0.52	16		0.06	1.3				
65	14	0.48	20		0.06	1.1				
80	11	0.44	11		0.03	1.7				
100	9	0.42	13		0.03	1.1				



30	$n_1 = 500$				KC				Input - IEC	
	i_n	n_2 [min ⁻¹]	Rd	P_{10}	T_2 [Nm]	P_1 [kW]	FS'	B5/B14		
	5	100	0.83	—	—	—	—	63	56	
7.5	67	0.80	—		—	—				
10	50	0.77	—		—	—				
15	33	0.72	—		—	—				
20	25	0.66	—		—	—				
25	20	0.62	—		—	—				
30	17	0.59	—		—	—				
40	13	0.51	—		—	—				
50	10	0.48	—		—	—				
65	8	0.43	—		—	—				
80	6	0.40	—		—	—				
100	5	0.38	—		—	—				



* **ATTENZIONE:** la coppia massima utilizzabile $[T_{2M}]$ deve essere calcolata utilizzando il fattore di servizio: $T_{2M} = T_2 \times FS'$

* **WARNING:** Maximum allowable torque $[T_{2M}]$ must be calculated using the following service factor: $T_{2M} = T_2 \times FS'$

* **ACHTUNG:** das max. anwendbare Drehmoment $[T_{2M}]$ muss mit folgendem Betriebsfaktor berechnet werden: $T_{2M} = T_2 \times FS'$

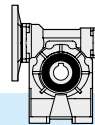



3.5 Dati tecnici

3.5 Technical data

3.5 Technische Daten

40	$n_1 = 2800$				KC				Input - IEC B5/B14		
	i_n	n_2 [min ⁻¹]	Rd	P_{t0}	T_2 [Nm]	P_1 [kW]	FS'	71	63	—	
 2.0	5	560	0.88	—	11.3	0.75	2.2				71
	7.5	373	0.87		17	0.75	1.8				
	10	280	0.86		22	0.75	1.4				
	15	187	0.82		32	0.75	1.0				
	20	140	0.80		30	0.55	1.0				
	25	112	0.76		24	0.37	1.1				
	30	93	0.73		28	0.37	1.3				
	40	70	0.70		24	0.25	1.4				
	50	56	0.65		28	0.25	1.1				
	65	43	0.61		24	0.18	1.2				
80	35	0.58	21	0.13	1.3						
100	28	0.55	24	0.13	1.0						

40	$n_1 = 1400$				KC				Input - IEC B5/B14		
	i_n	n_2 [min ⁻¹]	Rd	P_{t0}	T_2 [Nm]	P_1 [kW]	FS'	71	63	—	
 2.0	5	280	0.87	0.80	16.3	0.55	2.1				71
	7.5	187	0.85	0.80	24	0.55	1.7				
	10	140	0.83	0.70	31	0.55	1.3				
	15	93	0.79	0.50	30	0.37	1.4				
	20	70	0.76	0.50	38	0.37	1.0				
	25	56	0.72	0.40	31	0.25	1.1				
	30	47	0.68	0.40	35	0.25	1.2				
	40	35	0.64	0.30	38	0.22	1.0				
	50	28	0.59	0.30	36	0.18	1.1				
	65	22	0.54	0.20	31	0.13	1.1				
80	18	0.52	0.20	31	0.11	1.1					
100	14	0.49	0.20	30	0.09	0.9					

40	$n_1 = 900$				KC				Input - IEC B5/B14		
	i_n	n_2 [min ⁻¹]	Rd	P_{t0}	T_2 [Nm]	P_1 [kW]	FS'	71	63	—	
 2.0	5	180	0.85	—	16.7	0.37	2.5				71
	7.5	120	0.83		25	0.37	2.0				
	10	90	0.81		32	0.37	1.5				
	15	60	0.76		45	0.37	1.1				
	20	45	0.74		39	0.25	1.2				
	25	36	0.69		33	0.18	1.3				
	30	30	0.65		37	0.18	1.3				
	40	23	0.61		33	0.13	1.3				
	50	18	0.55		38	0.13	1.1				
	65	14	0.51		32	0.09	1.2				
80	11	0.48	37	0.09	1.0						
100	9	0.45	29	0.06	1.0						

40	$n_1 = 500$				KC				Input - IEC B5/B14		
	i_n	n_2 [min ⁻¹]	Rd	P_{t0}	T_2 [Nm]	P_1 [kW]	FS'	71	63	—	
 2.0	5	100	0.83	—	7.1	0.09	7.1				71
	7.5	67	0.81		10	0.09	5.5				
	10	50	0.79		14	0.09	4.4				
	15	33	0.73		19	0.09	3.1				
	20	25	0.70		24	0.09	2.3				
	25	20	0.65		28	0.09	1.7				
	30	17	0.61		31	0.09	1.8				
	40	13	0.57		39	0.09	1.3				
	50	10	0.51		44	0.09	1.2				
	65	8	0.46		52	0.09	0.9				
80	6	0.44	61*	0.09	0.7*						
100	5	0.41	71*	0.09	0.4*						

* **ATTENZIONE:** la coppia massima utilizzabile [T_{2M}] deve essere calcolata utilizzando il fattore di servizio: $T_{2M} = T_2 \times FS'$

* **WARNING:** Maximum allowable torque [T_{2M}] must be calculated using the following service factor: $T_{2M} = T_2 \times FS'$

* **ACHTUNG:** das max. anwendbare Drehmoment [T_{2M}] muss mit folgendem Betriebsfaktor berechnet werden: $T_{2M} = T_2 \times FS'$

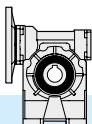

3.5 Dati tecnici

3.5 Technical data

3.5 Technische Daten

50	$n_1 = 2800$				KC				Input - IEC B5/B14		
	i_n	n_2 [min ⁻¹]	Rd	P_{t0}	T_2 [Nm]	P_1 [kW]	FS'	80	71	63	
Kg 3.4	5	560	0.89	—	22.8	1.5	1.9				—
	7.5	373	0.88		34	1.5	1.5				
	10	280	0.86		44	1.5	1.2				
	15	187	0.84		47	1.1	1.2				
	20	140	0.81		42	0.75	1.4				
	25	112	0.78		50	0.75	1.0				
	30	93	0.75		42	0.55	1.3				
	40	70	0.72		54	0.55	1.0				
	50	56	0.68		43	0.37	1.3				
	65	43	0.64		53	0.37	1.0				
80	35	0.61	41	0.25	1.2						
100	28	0.58	35	0.18	1.3						

50	$n_1 = 1400$				KC				Input - IEC B5/B14		
	i_n	n_2 [min ⁻¹]	Rd	P_{t0}	T_2 [Nm]	P_1 [kW]	FS'	80	71	63	
Kg 3.4	5	280	0.87	1.2	26.7	0.9	2.3				80
	7.5	187	0.86	1.2	40	0.9	1.8				
	10	140	0.84	1.0	52	0.9	1.4				
	15	93	0.80	0.80	74	0.9	1.0				
	20	70	0.78	0.70	58	0.55	1.3				
	25	56	0.74	0.60	47	0.37	1.4				
	30	47	0.71	0.60	53	0.37	1.2				
	40	35	0.67	0.50	68	0.37	1.0				
	50	28	0.62	0.40	53	0.25	1.3				
	65	22	0.58	0.40	64	0.25	1.0				
80	18	0.54	0.40	53	0.18	1.1					
100	14	0.51	0.30	45	0.13	1.2					

50	$n_1 = 900$				KC				Input - IEC B5/B14		
	i_n	n_2 [min ⁻¹]	Rd	P_{t0}	T_2 [Nm]	P_1 [kW]	FS'	80	71	63	
Kg 3.4	5	180	0.85	—	33.8	0.75	2.2				80
	7.5	120	0.84		50	0.75	1.6				
	10	90	0.82		66	0.75	1.3				
	15	60	0.78		68	0.55	1.3				
	20	45	0.75		59	0.37	1.5				
	25	36	0.71		70	0.37	1.1				
	30	30	0.67		79	0.37	1.0				
	40	23	0.63		67	0.25	1.1				
	50	18	0.59		78	0.25	1.0				
	65	14	0.54		67	0.18	1.1				
80	11	0.51	56	0.13	1.2						
100	9	0.47	45	0.09	1.3						

50	$n_1 = 500$				KC				Input - IEC B5/B14		
	i_n	n_2 [min ⁻¹]	Rd	P_{t0}	T_2 [Nm]	P_1 [kW]	FS'	80	71	63	
Kg 3.4	5	100	0.84	—	14.3	0.18	6.4				80
	7.5	67	0.82		21	0.18	4.7				
	10	50	0.80		28	0.18	3.8				
	15	33	0.75		39	0.18	2.7				
	20	25	0.72		50	0.18	2.1				
	25	20	0.68		58	0.18	1.5				
	30	17	0.63		65	0.18	1.5				
	40	13	0.59		81	0.18	1.2				
	50	10	0.54		93	0.18	1.0				
	65	8	0.50		56	0.09	1.5				
80	6	0.46	63	0.09	1.2						
100	5	0.43	74	0.09	0.8						

* **ATTENZIONE:** la coppia massima utilizzabile $[T_{2M}]$ deve essere calcolata utilizzando il fattore di servizio: $T_{2M} = T_2 \times FS'$

* **WARNING:** Maximum allowable torque $[T_{2M}]$ must be calculated using the following service factor: $T_{2M} = T_2 \times FS'$

* **ACHTUNG:** das max. anwendbare Drehmoment $[T_{2M}]$ muss mit folgendem Betriebsfaktor berechnet werden: $T_{2M} = T_2 \times FS'$

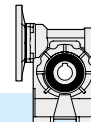

3.5 Dati tecnici

3.5 Technical data

3.5 Technische Daten

63	$n_1 = 2800$				KC				
	i_n	n_2 [min ⁻¹]	Rd	P_{t0}	T_2 [Nm]	P_1 [kW]	FS'	Input - IEC B5/B14	
	5	560	0.89	—	45.5	3	1.7	90	80
7.5	373	0.88	68		3	1.3			
10	280	0.87	89		3	1.1			
15	187	0.84	95		2.2	1.0			
20	140	0.83	85		1.5	1.3			
25	112	0.81	76		1.1	1.2			
30	93	0.77	87		1.1	1.3			
40	70	0.74	111		1.1	1.1	—	71	
50	56	0.70	90		0.75	1.1			
65	43	0.67	81		0.55	1.2			
80	35	0.64	65		0.37	1.4			
100	28	0.60	75		0.37	1.1			

5.7

63	$n_1 = 1400$				KC				
	i_n	n_2 [min ⁻¹]	Rd	P_{t0}	T_2 [Nm]	P_1 [kW]	FS'	Input - IEC B5/B14	
	5	280	0.88	1.8	54	1.8	2.0	90	80
7.5	187	0.87	1.8	80	1.8	1.5			
10	140	0.85	1.6	105	1.8	1.2			
15	93	0.81	1.2	125	1.5	1.1			
20	70	0.80	1.2	120	1.1	1.2			
25	56	0.77	1.0	118	0.9	1.0			
30	47	0.73	0.90	134	0.9	1.1	—		
40	35	0.69	0.80	142	0.75	1.1			
50	28	0.65	0.70	122	0.55	1.0			
65	22	0.61	0.60	100	0.37	1.2			
80	18	0.58	0.60	79	0.25	1.4			
100	14	0.53	0.50	91	0.25	1.1			

5.7

63	$n_1 = 900$				KC				
	i_n	n_2 [min ⁻¹]	Rd	P_{t0}	T_2 [Nm]	P_1 [kW]	FS'	Input - IEC B5/B14	
	5	180	0.87	—	69	1.5	1.9	90	80
7.5	120	0.85	102		1.5	1.4			
10	90	0.83	133		1.5	1.1			
15	60	0.79	139		1.1	1.1			
20	45	0.77	123		0.75	1.4			
25	36	0.74	109		0.55	1.3			
30	30	0.70	122		0.55	1.3	—		
40	23	0.66	154		0.55	1.1			
50	18	0.61	120		0.37	1.2			
65	14	0.57	98		0.25	1.4			
80	11	0.54	115		0.25	1.1			
100	9	0.50	95		0.18	1.2			

5.7

63	$n_1 = 500$				KC				
	i_n	n_2 [min ⁻¹]	Rd	P_{t0}	T_2 [Nm]	P_1 [kW]	FS'	Input - IEC B5/B14	
	5	100	0.85	—	20	0.25	8.3	90	80
7.5	67	0.83	30		0.25	5.9			
10	50	0.81	39		0.25	4.7			
15	33	0.76	55		0.25	3.4			
20	25	0.74	71		0.25	2.8			
25	20	0.71	85		0.25	1.9			
30	17	0.65	94		0.25	2.1	—		
40	13	0.62	118		0.25	1.7			
50	10	0.56	135		0.25	1.2			
65	8	0.52	163		0.25	1.0			
80	6	0.50	137		0.18	1.1			
100	5	0.45	77		0.09	1.6			

5.7

* **ATTENZIONE:** la coppia massima utilizzabile $[T_{2M}]$ deve essere calcolata utilizzando il fattore di servizio: $T_{2M} = T_2 \times FS'$

* **WARNING:** Maximum allowable torque $[T_{2M}]$ must be calculated using the following service factor: $T_{2M} = T_2 \times FS'$

* **ACHTUNG:** das max. anwendbare Drehmoment $[T_{2M}]$ muss mit folgendem Betriebsfaktor berechnet werden: $T_{2M} = T_2 \times FS'$

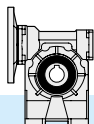

3.5 Dati tecnici

3.5 Technical data

3.5 Technische Daten

75	$n_1 = 2800$				KC					
	i_n	n_2 [min ⁻¹]	Rd	P_{t0}	T_2 [Nm]	P_1 [kW]	FS'	Input - IEC B5/B14		
									112 100	90
	7.5	373	0.89	—	125	5.5	1.0			
	10	280	0.88		120	4	1.2			
	15	187	0.85		131	3	1.2			
	20	140	0.84		171	3	1.0			
	25	112	0.82		154	2.2	1.0			
	30	93	0.78		120	1.5	1.4			
	40	70	0.75		154	1.5	1.2			
	50	56	0.73		136	1.1	1.2			
	65	43	0.69		114	0.75	1.4			
	80	35	0.66		135	0.75	1.1			
	100	28	0.62		159	0.75	0.8			

Kg
9.5

75	$n_1 = 1400$				KC					
	i_n	n_2 [min ⁻¹]	Rd	P_{t0}	T_2 [Nm]	P_1 [kW]	FS'	Input - IEC B5/B14		
									112 100	90
	7.5	187	0.87	2.5	178	4	1.0			
	10	140	0.86	2.3	176	3	1.1			
	15	93	0.83	1.9	187	2.2	1.1			
	20	70	0.81	1.7	199	1.8	1.1			
	25	56	0.78	1.5	200	1.5	1.0			
	30	47	0.74	1.2	167	1.1	1.3			
	40	35	0.71	1.1	213	1.1	1.1			
	50	28	0.67	1.0	206	0.9	1.0			
	65	22	0.63	0.90	154	0.55	1.3			
	80	18	0.60	0.80	180	0.55	1.0			
	100	14	0.56	0.70	210	0.55	0.8			

Kg
9.5

75	$n_1 = 900$				KC					
	i_n	n_2 [min ⁻¹]	Rd	P_{t0}	T_2 [Nm]	P_1 [kW]	FS'	Input - IEC B5/B14		
									112 100	90
	7.5	120	0.86	—	205	3	1.0			
	10	90	0.84		197	2.2	1.2			
	15	60	0.81		231	1.8	1.0			
	20	45	0.78		250	1.5	1.1			
	25	36	0.76		221	1.1	1.1			
	30	30	0.71		249	1.1	1.0			
	40	23	0.67		214	0.75	1.3			
	50	18	0.64		186	0.55	1.3			
	65	14	0.59		151	0.37	1.5			
	80	11	0.56		177	0.37	1.2			
	100	9	0.52		203	0.37	0.9			

Kg
9.5

75	$n_1 = 500$				KC					
	i_n	n_2 [min ⁻¹]	Rd	P_{t0}	T_2 [Nm]	P_1 [kW]	FS'	Input - IEC B5/B14		
									112 100	90
	7.5	67	0.84	—	90	0.75	2.9			
	10	50	0.82		118	0.75	2.4			
	15	33	0.78		167	0.75	1.7			
	20	25	0.75		216	0.75	1.5			
	25	20	0.72		260	0.75	1.1			
	30	17	0.67		288	0.75	1.1			
	40	13	0.63		265	0.55	1.2			
	50	10	0.59		210	0.37	1.3			
	65	8	0.55		251	0.37	1.0			
	80	6	0.52		197	0.25	1.2			
	100	5	0.47		161	0.18	1.3			

Kg
9.5

* **ATTENZIONE:** la coppia massima utilizzabile $[T_{2M}]$ deve essere calcolata utilizzando il fattore di servizio: $T_{2M} = T_2 \times FS'$

* **WARNING:** Maximum allowable torque $[T_{2M}]$ must be calculated using the following service factor: $T_{2M} = T_2 \times FS'$

* **ACHTUNG:** das max. anwendbare Drehmoment $[T_{2M}]$ muss mit folgendem Betriebsfaktor berechnet werden: $T_{2M} = T_2 \times FS'$

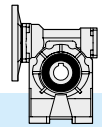

3.5 Dati tecnici

3.5 Technical data

3.5 Technische Daten

90	$n_1 = 2800$				KC					
	i_n	n_2 [min ⁻¹]	Rd	P_{t0}	T_2 [Nm]	P_1 [kW]	FS'	Input - IEC B5/B14		
	7.5	373	0.89	—	171	7.5	1.2	112 100	90	—
10	280	0.88	165		5.5	1.3				
15	187	0.86	241		5.5	1.0				
20	140	0.84	230		4	1.2				
25	112	0.83	212		3	1.2				
30	93	0.79	243		3	1.1				
40	70	0.77	230		2.2	1.3	—	80		
50	56	0.74	278		2.2	1.0				
65	43	0.71	235		1.5	1.1				
80	35	0.68	205		1.1	1.2				
100	28	0.64	163		0.75	1.3				

 16.4

90	$n_1 = 1400$				KC					
	i_n	n_2 [min ⁻¹]	Rd	P_{t0}	T_2 [Nm]	P_1 [kW]	FS'	Input - IEC B5/B14		
	7.5	187	0.88	3.0	247	5.5	1.2	112 100	90	—
10	140	0.86	2.5	236	4	1.3				
15	93	0.84	2.2	256	3	1.2				
20	70	0.82	2.0	334	3	1.1				
25	56	0.80	1.8	299	2.2	1.1				
30	47	0.76	1.5	340	2.2	1.0				
40	35	0.72	1.3	355	1.8	1.1	—	80		
50	28	0.69	1.1	353	1.5	1.0				
65	22	0.65	1.0	317	1.1	1.0				
80	18	0.63	1.0	309	0.9	1.0				
100	14	0.58	0.80	217	0.55	1.2				

 16.4

90	$n_1 = 900$				KC					
	i_n	n_2 [min ⁻¹]	Rd	P_{t0}	T_2 [Nm]	P_1 [kW]	FS'	Input - IEC B5/B14		
	7.5	120	0.86	—	206	3	1.7	112 100	90	—
10	90	0.85	270		3	1.3				
15	60	0.82	286		2.2	1.3				
20	45	0.79	371		2.2	1.1				
25	36	0.77	369		1.8	1.0				
30	30	0.73	416		1.8	1.0				
40	23	0.69	440		1.5	1.0	—	80		
50	18	0.66	384		1.1	1.0				
65	14	0.62	319		0.75	1.1				
80	11	0.59	274		0.55	1.2				
100	9	0.54	313		0.55	1.0				

 16.4

90	$n_1 = 500$				KC					
	i_n	n_2 [min ⁻¹]	Rd	P_{t0}	T_2 [Nm]	P_1 [kW]	FS'	Input - IEC B5/B14		
	7.5	67	0.84	—	91	0.75	4.7	112 100	90	—
10	50	0.83	118		0.75	3.7				
15	33	0.79	169		0.75	2.7				
20	25	0.76	219		0.75	2.3				
25	20	0.74	265		0.75	1.7				
30	17	0.68	294		0.75	1.6				
40	13	0.65	371		0.75	1.4	—	80		
50	10	0.61	439		0.75	1.1				
65	8	0.57	388		0.55	1.1				
80	6	0.54	305		0.37	1.3				
100	5	0.49	344		0.37	1.0				

 16.4

* **ATTENZIONE:** la coppia massima utilizzabile $[T_{2M}]$ deve essere calcolata utilizzando il fattore di servizio: $T_{2M} = T_2 \times FS'$

* **WARNING:** Maximum allowable torque $[T_{2M}]$ must be calculated using the following service factor: $T_{2M} = T_2 \times FS'$

* **ACHTUNG:** das max. anwendbare Drehmoment $[T_{2M}]$ muss mit folgendem Betriebsfaktor berechnet werden: $T_{2M} = T_2 \times FS'$

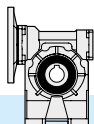

3.5 Dati tecnici

3.5 Technical data

3.5 Technische Daten

110	$n_1 = 2800$				KC					
	i_n	n_2 [min ⁻¹]	Rd	P_{t0}	T_2 [Nm]	P_1 [kW]	FS'	Input - IEC B5/B14		
									132	112 100
 31.5	7.5	373	0.89	—	343	15	1.0	—	112 100	—
	10	280	0.88		332	11	1.1			90
	15	187	0.86		331	7.5	1.2			—
	20	140	0.85		435	7.5	1.1			—
	25	112	0.84		393	5.5	1.1			—
	30	93	0.80		450	5.5	1.0			—
	40	70	0.78		424	4	1.2			—
	50	56	0.76		388	3	1.2			—
	65	43	0.73		354	2.2	1.2			—
	80	35	0.70		287	1.5	1.4			—
100	28	0.66	339	1.5	1.1	—				

110	$n_1 = 1400$				KC					
	i_n	n_2 [min ⁻¹]	Rd	P_{t0}	T_2 [Nm]	P_1 [kW]	FS'	Input - IEC B5/B14		
									132	112 100
 31.5	7.5	187	0.88	4.3	415	9.2	1.2	—	112 100	—
	10	140	0.87	4.0	446	7.5	1.1			90
	15	93	0.84	3.2	475	5.5	1.1			—
	20	70	0.83	3.0	623	5.5	1.0			—
	25	56	0.81	2.7	554	4	1.0			—
	30	47	0.77	2.2	472	3	1.3			—
	40	35	0.74	2.0	606	3	1.1			—
	50	28	0.72	1.8	538	2.2	1.1			—
	65	22	0.68	1.6	451	1.5	1.2			—
	80	18	0.65	1.5	390	1.1	1.3			—
100	14	0.61	1.3	458	1.1	1.0	—			

110	$n_1 = 900$				KC					
	i_n	n_2 [min ⁻¹]	Rd	P_{t0}	T_2 [Nm]	P_1 [kW]	FS'	Input - IEC B5/B14		
									132	112 100
 31.5	7.5	120	0.87	—	381	5.5	1.5	—	112 100	—
	10	90	0.86		500	5.5	1.2			90
	15	60	0.83		526	4	1.2			—
	20	45	0.81		685	4	1.1			—
	25	36	0.79		628	3	1.1			—
	30	30	0.74		520	2.2	1.3			—
	40	23	0.71		664	2.2	1.1			—
	50	18	0.68		653	1.8	1.1			—
	65	14	0.64		487	1.1	1.2			—
	80	11	0.61		570	1.1	1.0			—
100	9	0.57	450	0.75	1.1	—				

110	$n_1 = 500$				KC					
	i_n	n_2 [min ⁻¹]	Rd	P_{t0}	T_2 [Nm]	P_1 [kW]	FS'	Input - IEC B5/B14		
									132	112 100
 31.5	7.5	67	0.85	—	183	1.5	3.9	—	112 100	—
	10	50	0.84		240	1.5	3.1			90
	15	33	0.80		344	1.5	2.3			—
	20	25	0.78		446	1.5	1.9			—
	25	20	0.76		542	1.5	1.5			—
	30	17	0.70		603	1.5	1.4			—
	40	13	0.67		765	1.5	1.2			—
	50	10	0.64		671	1.1	1.2			—
	65	8	0.59		553	0.75	1.3			—
	80	6	0.56		643	0.75	1.0			—
100	5	0.52	542	0.55	1.1	—				

* **ATTENZIONE:** la coppia massima utilizzabile $[T_{2M}]$ deve essere calcolata utilizzando il fattore di servizio: $T_{2M} = T_2 \times FS'$

* **WARNING:** Maximum allowable torque $[T_{2M}]$ must be calculated using the following service factor: $T_{2M} = T_2 \times FS'$

* **ACHTUNG:** das max. anwendbare Drehmoment $[T_{2M}]$ muss mit folgendem Betriebsfaktor berechnet werden: $T_{2M} = T_2 \times FS'$

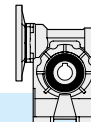

3.5 Dati tecnici

3.5 Technical data

3.5 Technische Daten

130	$n_1 = 2800$				KC					
	i_n	n_2 [min ⁻¹]	Rd	P_{t0}	T_2 [Nm]	P_1 [kW]	FS'	Input - IEC B5/B14		
								132	112 100	—
Kg 45	7.5	373	0.90	—	345	15	1.5	132	112 100	—
	10	280	0.89		455	15	1.2			
	15	187	0.87		490	11	1.3			
	20	140	0.86		645	11	1.1			
	25	112	0.85		667	9.2	1.1			
	30	93	0.81		622	7.5	1.2			
	40	70	0.80		819	7.5	1.0			
	50	56	0.78		732	5.5	1.0			
	65	43	0.75		499	3	1.3			
	80	35	0.73		598	3	1.1			
	100	28	0.70		525	2.2	1.1			
							—		90	

130	$n_1 = 1400$				KC					
	i_n	n_2 [min ⁻¹]	Rd	P_{t0}	T_2 [Nm]	P_1 [kW]	FS'	Input - IEC B5/B14		
								132	112 100	—
Kg 45	7.5	187	0.89	6.0	418	9.2	1.8	132	112 100	—
	10	140	0.88	5.5	552	9.2	1.4			
	15	93	0.85	4.4	803	9.2	1.1			
	20	70	0.84	4.1	860	7.5	1.1			
	25	56	0.83	3.9	778	5.5	1.2			
	30	47	0.79	3.2	883	5.5	1.1			
	40	35	0.76	2.8	829	4	1.3			
	50	28	0.74	2.6	757	3	1.3			
	65	22	0.71	2.3	678	2.2	1.2			
	80	18	0.68	2.1	649	1.8	1.2			
	100	14	0.64	1.8	655	1.5	1.1			
							—		90	

130	$n_1 = 900$				KC					
	i_n	n_2 [min ⁻¹]	Rd	P_{t0}	T_2 [Nm]	P_1 [kW]	FS'	Input - IEC B5/B14		
								132	112 100	—
Kg 45	7.5	120	0.88	—	385	5.5	2.3	132	112 100	—
	10	90	0.87		508	5.5	1.8			
	15	60	0.84		735	5.5	1.4			
	20	45	0.82		957	5.5	1.2			
	25	36	0.81		860	4	1.3			
	30	30	0.76		968	4	1.2			
	40	23	0.73		930	3	1.3			
	50	18	0.70		817	2.2	1.3			
	65	14	0.67		832	1.8	1.1			
	80	11	0.64		815	1.5	1.1			
	100	9	0.60		700	1.10	1.2			
							—		90	

130	$n_1 = 500$				KC					
	i_n	n_2 [min ⁻¹]	Rd	P_{t0}	T_2 [Nm]	P_1 [kW]	FS'	Input - IEC B5/B14		
								132	112 100	—
Kg 45	7.5	67	0.86	—	228	1.85	4.9	132	112 100	—
	10	50	0.84		297	1.85	3.7			
	15	33	0.81		429	1.85	2.9			
	20	25	0.79		558	1.85	2.5			
	25	20	0.78		689	1.85	1.8			
	30	17	0.72		763	1.85	1.7			
	40	13	0.69		975	1.85	1.5			
	50	10	0.66		1166	1.85	1.1			
	65	8	0.63		860	1.10	1.3			
	80	6	0.59		992	1.10	1.1			
	100	5	0.55		788	0.75	1.2			
							—		90	

* **ATTENZIONE:** la coppia massima utilizzabile $[T_{2M}]$ deve essere calcolata utilizzando il fattore di servizio: $T_{2M} = T_2 \times FS'$

* **WARNING:** Maximum allowable torque $[T_{2M}]$ must be calculated using the following service factor: $T_{2M} = T_2 \times FS'$

* **ACHTUNG:** das max. anwendbare Drehmoment $[T_{2M}]$ muss mit folgendem Betriebsfaktor berechnet werden: $T_{2M} = T_2 \times FS'$

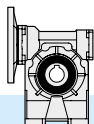

3.6 **Momenti d' inerzia** [Kg·cm²]
(riferiti all'albero veloce in entrata)

3.6 **Moments of inertia** [Kg·cm²]
(referred to input shaft)

3.6 **Trägheitsmoment** [Kg·cm²]
(bez. Antriebswelle)

	i_n	KC B5 - B14	
		IEC 56	IEC 63
		5	0.130
7.5	0.112	0.109	
10	0.103	0.100	
15	0.097	0.094	
20	0.095	0.092	
25	0.094	0.091	
30	0.093	0.090	
40	0.093	0.090	
50	0.092	0.089	
65	0.079	-	
80	0.079	-	
100	0.078	-	

	i_n	KC B5 - B14		
		IEC 56	IEC 63	IEC 71
		5	-	0.391
7.5	-	0.321	0.356	
10	-	0.272	0.347	
15	-	0.266	0.340	
20	-	0.263	0.338	
25	-	0.262	0.337	
30	-	0.262	0.337	
40	-	0.261	0.336	
50	0.182	0.261	-	
65	0.182	0.261	-	
80	0.182	0.261	-	
100	0.182	0.261	-	

	i_n	KC B5 - B14		
		IEC 63	IEC 71	IEC 80
		5	-	0.922
7.5	-	0.684	0.935	
10	-	0.602	0.853	
15	-	0.543	0.794	
20	-	0.523	0.774	
25	-	0.513	0.764	
30	-	0.508	0.759	
40	0.315	0.503	-	
50	0.313	0.501	-	
65	0.311	0.499	-	
80	0.310	0.498	-	
100	0.309	0.498	-	

	i_n	KC B5 - B14		
		IEC 71	IEC 80	IEC 63
		5	-	2.431
7.5	-	1.949	2.269	
10	-	1.744	2.063	
15	-	1.597	1.916	
20	-	1.545	1.864	
25	-	1.514	1.833	
30	-	1.508	1.828	
40	0.966	1.495	-	
50	0.959	1.488	-	
65	0.955	1.484	-	
80	0.953	1.482	-	
100	0.952	1.481	-	

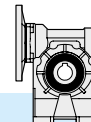



3.6 **Momenti d' inerzia** [Kg·cm²]
(riferiti all'albero veloce in entrata)

3.6 **Moments of inertia** [Kg·cm²]
(referred to input shaft)

3.6 **Trägheitsmoment** [Kg·cm²]
(bez. Antriebswelle)

	i_n	 KC		
		B5 - B14		
		IEC 80	IEC 90	IEC 100-112
K75	7.5	-	3.712	4.462
	10	-	3.234	3.984
	15	-	2.893	3.643
	20	-	2.774	3.523
	25	-	2.709	3.458
	30	-	2.689	3.438
	40	1.595	2.659	-
	50	1.578	2.642	-
	65	1.569	2.633	-
	80	1.565	2.629	-
	100	1.562	2.626	-

	i_n	 KC		
		B5 - B14		
		IEC 80	IEC 90	IEC 100-112
K90	7.5	-	6.898	7.671
	10	-	5.875	6.648
	15	-	5.144	5.917
	20	-	3.398	5.661
	25	-	3.256	5.520
	30	-	3.215	5.479
	40	-	3.151	-
	50	-	3.115	-
	65	2.024	3.096	-
	80	2.014	3.087	-
	100	2.008	3.080	-

	i_n	 KC		
		B5 - B14		
		IEC 90	IEC 100-112	IEC 132
K110	7.5	-	17.980	20.038
	10	-	15.119	17.177
	15	-	13.076	15.134
	20	-	8.367	14.418
	25	-	7.969	14.020
	30	-	11.850	13.908
	40	-	7.677	-
	50	-	7.578	-
	65	5.592	7.510	-
	80	5.570	7.489	-
	100	5.555	7.474	-

	i_n	 KC		
		B5 - B14		
		IEC 90	IEC 100-112	IEC 132
K130	7.5	-	40.70	42.78
	10	-	32.96	35.04
	15	-	27.43	29.51
	20	-	16.68	27.58
	25	-	15.52	26.42
	30	-	24.12	26.20
	40	-	14.81	25.71
	50	-	12.57	-
	65	10.46	14.35	-
	80	10.41	14.30	-
	100	10.37	14.26	-

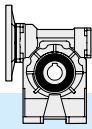

3.7 Dimensioni

3.7 Dimensions

3.7 Abmessungen

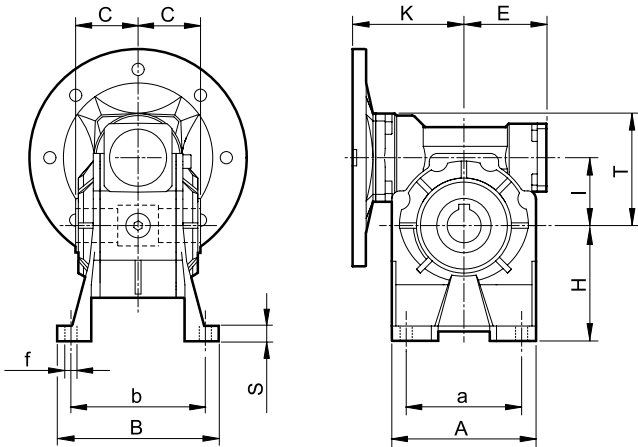

KC..A

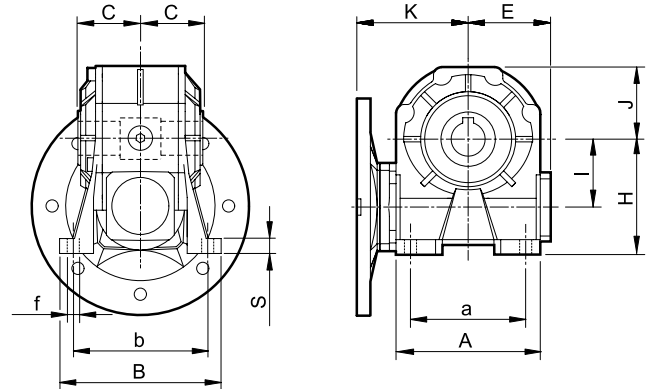

KC..B

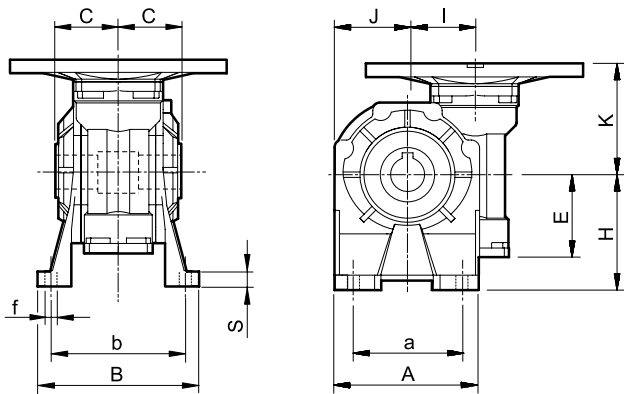

KC..V

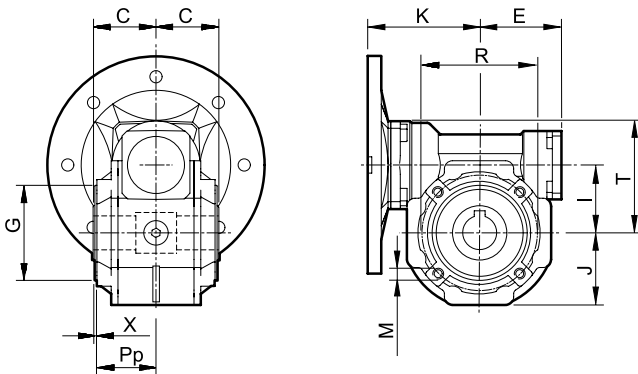

Flangia pendolare / Side cover for shaft mounting / Aufsteckflansch

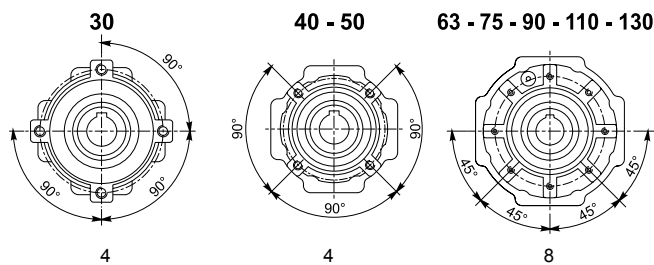

Fori / Holes / Bohrungen Fori / Holes / Bohrungen Fori / Holes / Bohrungen

KC..P

	30	40	50	63	75	90	110	130
b2	5	6 (6)	8 (8)	8	8 (8)	10	12	14
C	31.5	39	46	56	60	70	77.5	85
D2 H8	14	18 (19)	25 (24)	25	28 (30)	35	42	45 (48)
E	41	51	60	71	85	103	127.5	147.5
G h8	55	60	70	80	95	110	130	180
I	31.5	40	50	63	75	90	110	130
J	37.5	43.5	53.5	64	78	100	122	131
K	57	75	82	97	114	122	153	173
M	M6x8	M6x10	M8x10	M8x14	M8x14	M10x18	M10x18	M12x20
Pp	29	36.5	43.5	53	57	67	74	81
R	65	75	85	95	115	130	165	215
T	52.5	68.5	82.5	100.5	116.5	131.5	161.5	181
t2	16.3	20.8 (21.8)	28.3 (27.3)	28.3	31.3 (33.3)	38.3	45.3	48.8 (51.8)
X	1.5	1.5	1.5	2	2	2	2.5	3

	Piedi Feet Fuß	30	40	50	63	75	90	110	130
A	1	67	86.5	106	127.5	155.5	190	250	295
	2	67	86.5	106			190	250	
a	1	40-52	70	63-85	95	120	140	200	235
	2	40-52	52	63-85			140	200	220
B	1	78	98	119	136	140	168	210	229
	2	78	98	119			168	210	
b	1	66	84	99	111	115	140	162	190
	2	66	81	99			146	181	
f	1	6.5	7	9	11	11	13	13	15
	2	6.5	8.5	9			11	13	
H	1	52	71	85	100	115	135	172	200
	2	55	72	82			142	170	
S	1	5	9	11	12	12	14	17	20
	2	8	10	8			14	15	

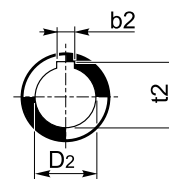

Albero uscita cavo
Hollow output shaft
Abtriebshohlwelle

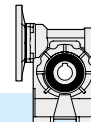

3.7 Dimensioni

3.7 Dimensions

3.7 Abmessungen

Flangia uscita / Output flange / Abtriebsflansch

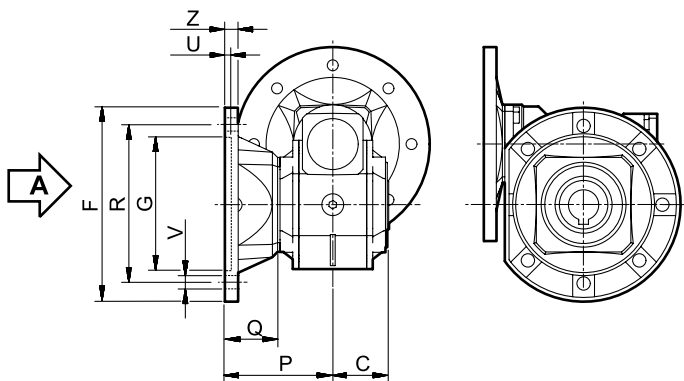

KC..F

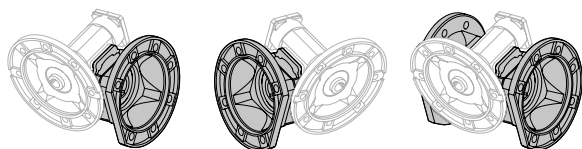

F...D
Standard

F...S

F...2

Vista da A / View from A / Ansicht von A

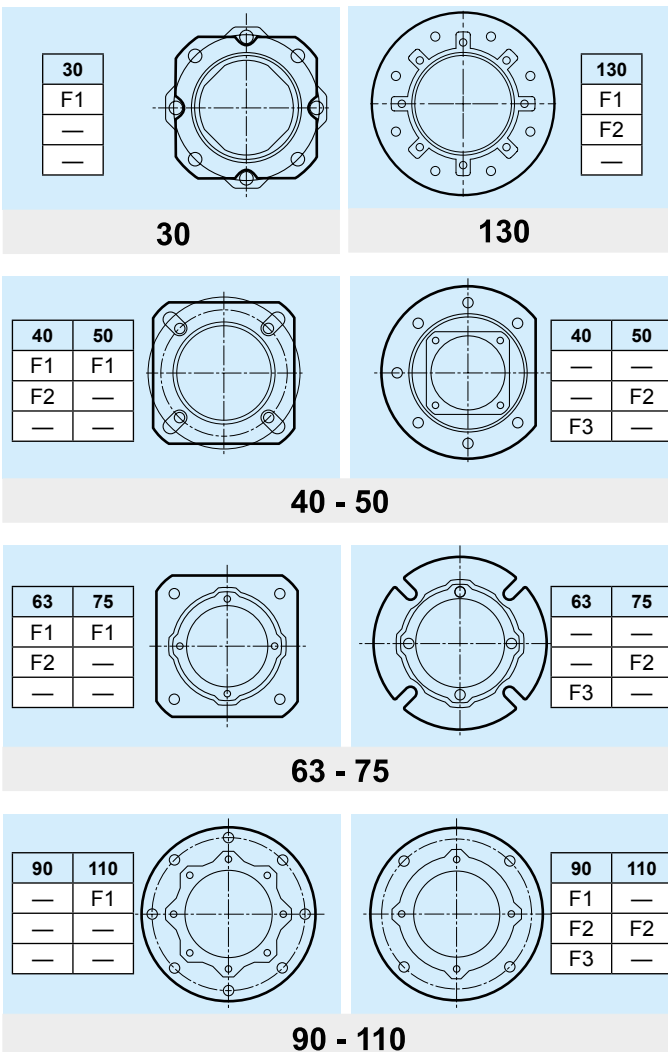

KC	C	F		G H8	P	Q	R	U	V			Z
											∅	
30	31.5	F1	66	50	54.5	23	68	4	n° 4		6.5	6
		F2										
		F3										
40	39	F1	85	60	67	28	75-90	4	n° 4		9	8
		F2	85	60	97	58	75-90	4	n° 4		9	8
		F3	140	95	80	41	115	5		n° 7	9	10
50	46	F1	94	70	90	44	85-100	5	n° 4		11	10
		F2	160	110	89	43	130	5		n° 7	11	11
		F3										
63	56	F1	142	115	82	26	150	5	n° 4		11	11
		F2	142	115	112	56	150	5	n° 4		11	11
		F3	160	110	80.5	24.5	130	5	n° 4		11	12
75	60	F1	160	130	111	51	165	5	n° 4		13	12
		F2	160	110	90	30	130	6	n° 4		11	13
		F3										
90	70	F1	200	152	111	41	175	5	n° 4		13	12
		F2	200	152	151	81	175	5	n° 4		13	13
		F3	200	130	110	40	165	6	n° 4		11	11
110	77.5	F1	260	170	131	53.5	230	6		n° 8	13	15
		F2	250	180	150	72.5	215	5	n° 4		15	16
		F3										
130	85	F1	320	180	140	55	255	7		n° 8 *	16	16
		F2	300	230			265					
		F3										

* Foratura ruotata di 22.5°

* Drilling turned of 22.5°

* Durchbohrung 22.5° versetzt

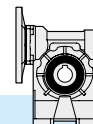

3.8 Entrata supplementare (vite bisporgente)

3.8 Additional input (double extended shaft)

3.8 Zusatzantrieb (beidseitige Welle)

S.e.A.

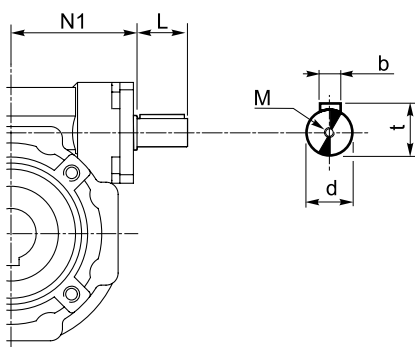

KC	d j6	L	M	N1	b	t
30	9	15	M4x10	42.5	3	10.2
40	11	20	M4x12	52.5	4	12.5
50	14	25	M5x13	62.5	5	16
63	19	30	M8x20	72.5	6	21.5
75	24	40	M8x20	89	8	27
90	24	40	M8x20	108	8	27
110	28	50	M8x20	132.5	8	31
130	38	70	M10x25	152	10	41

3.9 Limitatore di coppia cavo passante

3.9 Torque limiter with through hollow shaft

3.9 Drehmomentbegrenzer mit durchgehender Hohlwelle

Il limitatore di coppia viene consigliato in tutte quelle applicazioni che richiedono una limitazione sulla coppia trasmissibile per proteggere l'impianto e/o preservare il riduttore evitando sovraccarichi o urti indesiderati quanto inaspettati.

È un dispositivo con albero dotato di cavo passante, con funzionamento a frizione, ed è integrato al riduttore, presentando un ingombro limitato.

Concepito per lavorare a bagno d'olio, il dispositivo risulta affidabile nel tempo ed è esente da usura se non viene mantenuto in condizioni prolungate di slittamento (condizione che si verifica quando la coppia presenta valori superiori a quelli di taratura).

La taratura è facilmente regolabile dall'esterno attraverso il serraggio di una ghiera autobloccante che porta a compressione le 4 molle a tazza disposte tra loro in serie.

Il dispositivo non consente:

- l'impiego di cuscinetti a rulli conici in uscita
- funzionamento prolungato in condizioni di slittamento.

Nella tabella seguente vengono riportati i valori delle coppie di slittamento M_{2S} in funzione del n° di giri della ghiera.

I valori di taratura presentano una tolleranza del $\pm 10\%$ e si riferiscono ad una condizione statica.

In condizioni dinamiche è da notare che la coppia di slittamento assume valori diversi a seconda del tipo e/o modalità in cui si verifica il sovraccarico: con valori maggiori in caso di carico uniformemente crescente rispetto a valori più contenuti in seguito al verificarsi di picchi improvvisi di carico.

NOTA: quando si supera il valore di taratura si ha slittamento. Il coefficiente di attrito tra le superfici di contatto da statico diventa dinamico e la coppia trasmessa cala del 30% circa.

E' quindi opportuno prevedere uno stop per poter ripartire al valore di taratura iniziale.

The use of a torque limiter is advisable when the application requires the limitation of the transmissible torque to safeguard the plant and/or the gearbox from unexpected or undesired overloads.

The torque limiter is equipped with a through hollow shaft and a friction clutch. It is integrated in the gearbox, therefore space requirement is limited.

Designed to be working in oil bath, the device is reliable over time and is not subject to wear unless in case of operation with prolonged slipping (it occurs when the torque values are higher than the calibration values).

Calibration can be easily adjusted from outside by tightening the self-locking ring nut, which causes the compression of the 4 Belleville washers arranged in series.

The device does not go together with:

- the use of tapered roller bearings at output
- prolonged operation under slipping conditions

The following table shows the values of M_{2S} slipping torques depending on the number of revolutions of the ring nut.

Calibration values feature a $\pm 10\%$ tolerance and refer to static conditions.

Under dynamic conditions the values of the slipping torque will change according to the type of overload: the values are higher if the load increase is uniform; the values are lower if sudden load peaks occur.

NOTE: *Slipping occurs when the setting values are exceeded.*

The friction coefficient between the contact surfaces from static becomes dynamic and the transmitted torque is approx. 30% lower.

It is advisable to have a stop first in order to have a restart based on the initial setting value.

Die Anwendung eines Drehmomentbegrenzers wird empfohlen, um die Anlage und/oder das Getriebe gegen ungewünschte und unerwartete Überbelastungen zu schützen.

Es handelt sich um eine Vorrichtung mit einer durchgehender Hohlwelle.

Er ist in dem Getriebe integriert, d.h. der Raumbedarf ist klein. Der Begrenzer wurde für Betrieb in einem Ölbad entworfen.

Er ist zuverlässig über Zeit und verschleißfest (ausser wenn Rutschen für lange Zeit besteht: das passiert, wenn das Drehmoment höher als der Eichwert ist).

Die Einstellung darf mühelos von aussen durch das Anziehen einer selbstsperrenden Mutter ausgeführt werden. Das Anziehen verursacht die Zusammendrückung der 4 wechelsinnigeschichteten Tellerfeder.

Die Vorrichtung sieht das folgende nicht vor:

- die Verwendung von Kegelrollenlager am Abtrieb
- Längerer Rutschbetrieb

Die nachstehende Tabelle zeigt die Werte der Rutschmomente M_{2S} abhängig von der Zahl der Umdrehungen der Mutter.

Die Eichwerte weisen $\pm 10\%$ Toleranz auf und beziehen sich auf statische Bedingungen.

Unter dynamischen Bedingungen hat das Rutschmoment verschiedene Werte je nach Art der Überbelastung. Die Werte sind höher, wenn die Belastung gleichmäßig zunimmt; sie sind niedriger im Falle von plötzlichen Belastungsspitzen.

BEMERKUNG: Rutschen tritt auf, wenn die eingestellten Werte überschritten werden. Der Reibungskoeffizient zwischen den Berührungsflächen wird dynamisch anstatt statisch und das übertragene Drehmoment sinkt um ca. 30%.

Es ist daher ratsam, vor dem erneuten Anfahren anzuhalten, um die ursprünglichen Drehmomentwerte zu erreichen.

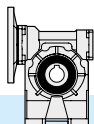

E' importante notare che la coppia di slittamento non resta sempre la medesima durante tutta la vita del limitatore.

Tende infatti a diminuire in rapporto al numero e alla durata degli slittamenti che, rodando le superfici di contatto, ne aumentano il rendimento.

È quindi opportuno verificare periodicamente, soprattutto durante la fase di rodaggio, la taratura del dispositivo.

Là dove sia richiesto un errore più contenuto nella taratura, è necessario testare la coppia trasmissibile sull'impianto.

Il dispositivo viene consegnato tarato alla coppia riportata a catalogo T_{2M} salvo diversa indicazione espressa in fase di ordinazione.

It is important to note that the slipping torque is not the same for the entire life of the torque limiter.

It usually decreases in connection with the number and the duration of slippings, this is due to the surfaces of the torque limiter becoming more engaged, therefore increasing the efficiency.

For this reason it is advisable to check the calibration of the device at regular intervals, specially during the running-in period.

Should a smaller calibration error be required, it is necessary to test the transmissible torque on the plant.

The torque limiter is supplied already calibrated at the torque value reported in the catalogue T_{2M}, unless otherwise specified in the order.

Es ist wichtig zu beachten, dass das Rutschmoment der Rutschkupplung über die gesamte Lebensdauer nicht konstant bleibt, sondern üblicherweise in Verbindung mit längeren Rutschzyklen aufgrund der eingelaufenen Berührungsflächen abnimmt.

Deswegen ist es ratsam, die Einstellung der Vorrichtung besonders während der Einlaufzeit in regelmäßigen Zeitabständen zu prüfen.

Falls ein niedriger Eichfehler verlangt wird, ist das übersetzbare Drehmoment auf der Anlage zu testen.

Wenn die Vorrichtung geliefert wird, ist sie schon auf dem im Katalog T_{2M} angegebenen Drehmoment geeicht, ausser wenn es in der Bestellung anders angegeben wird.

K	N°. giri della ghiera di regolazione / N°. revolutions of ring nut / Nr. Umdrehungen der Mutter															
	3/4	1	1 1/4	1 1/2	1 3/4	2	2 1/4	2 1/2	2 3/4	3	3 1/4	3 1/2	3 3/4	4	4 1/4	4 1/2
	M _{2S} [Nm]															
30		15	18	22	27	32										
40	23	30	35	40	45	50	60									
50		45	60	70	80	90	100	110								
63			80	90	100	110	120	130	140	150	160	170	180	190	200	
75		140	160	180	200	220	240	260	280	300						
90						230	280	310	330	350	380	410	435	460	490	510
110		420	500	560	670	730	810	910								
130																

Disposizione delle molle
Washers' arrangement
Lage der Feder

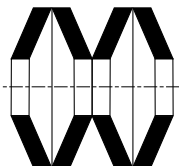

IN SERIE (min. coppia, max. sensibilità)
SERIES (min. torque, max sensitivity)
SERIE (min. Moment, max. Empfindlichkeit)

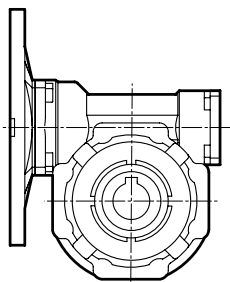
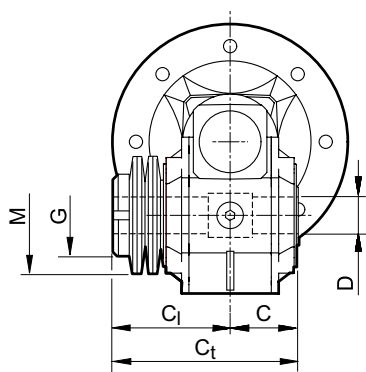

KC	C	C _l	C _t	D H ₈	M	G
30	31.5	55.5	87	14	50x25.4x1.25	M25x1.5
40	39	65	104	18 (19)	56x30.5x1.5	M30x1.5
50	46	76	122	25 (24)	63x40.5x1.8	M40x1.5
63	56	91	147	25	71x40.5x2	M40x1.5
75	60	100	160	28 (30)	90x50.5x2.5	M50x1.5
90	70	109	179	35 (32)	100x51x2.7	M50x1.5
110	77.5	127.5	205	42	125x61x4	M60x2.0
130						

() A richiesta / On request / Auf Anfrage

Nella versione con limitatore non è prevista la fornitura degli alberi lenti.

The version with torque limiter is supplied without output shafts.

Die Version mit Drehmomentbegrenzer wird ohne Abtriebswellen geliefert.

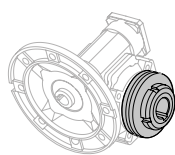

LD

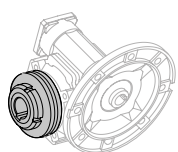

LS

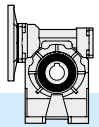

3.10 Accessori

3.10 Accessories

3.10 Accessories

Albero lento

Output shaft

Abtriebswelle

Albero lento semplice
Single output shaft
Standard Abtriebswelle

Albero lento doppio
Double output shaft
Doppelte Abtriebswelle

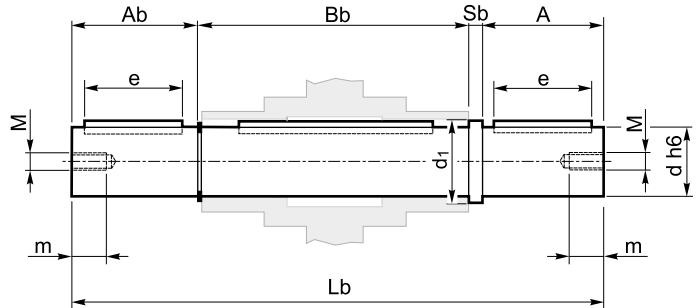
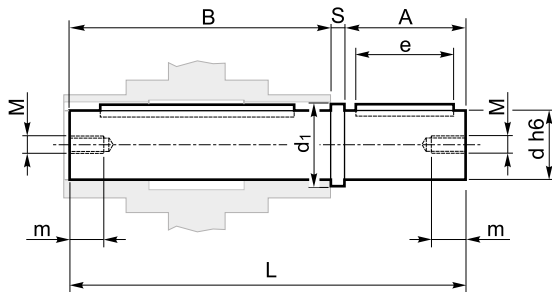

KC	A	B	d _{h6}		d ₁	e	L	M	m	S
30	30	62	14		18.5	20	94.5	M6	16	2.5
40	40	77	18	19	23.5	30	120	M6	16	3
50	50	90	25	24	31.5	40	143.5	M8	22	3.5
63	50	111	25		31.5	40	165	M8	22	4
75	60	119	28	30	34.5	50	183	M8	22	4
90	80	139	35		41.5	60	224	M10	28	5
110	80	154.5	42		49.5	60	242.5	M10	28	8
130	80	168	45		54.5	70	253	M16	36	5

A	A _b	B _b	d _{h6}	d ₁	e	L _b	S _b
30	29	64	14	18.5	20	126	2.5
40	39	79	18	23.5	30	161	3
50	49	93	25	31.5	40	195.5	3.5
50	49	113	25	31.5	40	216	4
60	59	121	28	34.5	50	244	4
80	78.5	141.5	35	41.5	60	305	5
80	77.5	157	42	49.5	60	322.5	8
80	78	172	45	54.5	70	335	5

Braccio di reazione

Torque arm

Drehmomentstütze

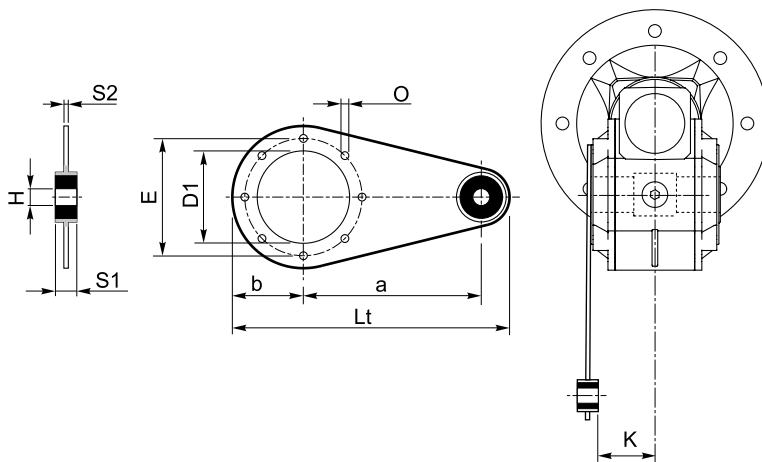

KC	a	b	D ₁	E	H	K	L _t	O	S1	S2
30	85	37.5	55	65	8	24	141.5	7	14	4
40	100	45	60	75	10	31.5	167	7	14	4
50	100	50	70	85	10	39	172	9	14	5
63	150	55	80	95	10	49	227	9	14	6
75	200	70	95	115	20	47.5	302	9	25	6
90	200	80	110	130	20	57.5	312	11	25	6
110	250	100	130	165	25	62	390	11	30	6
130	250	125	180	215	25	69	415	13	30	6

Kit di protezione: solo su versione P

Protection Kit: only for P Version

Schutzvorrichtung: nur für Version P

Albero cavo / Hollow shaft / Hohlwelle

Limitatore di coppia / Torque limiter / Drehmomentbegrenzer

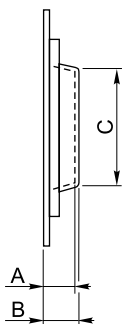

KC	A	B	C
30	12	13	39
40	14	15.5	44
50	15	16.5	54
63	17	19	60
75	18	20	70
90	21.5	24	80
110	22	25	96
130	22	25	130

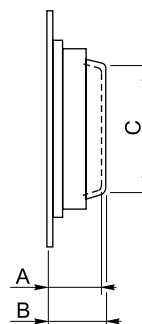

KC	A	B	C
30	36	37	36
40	40	41.5	44
50	47	48.5	53
63	52	54	55
75	58	60	68
90	60.5	63	70
110	72	75	85
130			

Opzioni disponibili:

Available options:

Auf Anfrage ist folgendes Zubehör erhältlich:

Cuscinetti a rulli conici corona

Tapered roller bearing for worm wheel

Kegelrollenlager für Schneckenrad

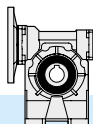

KC

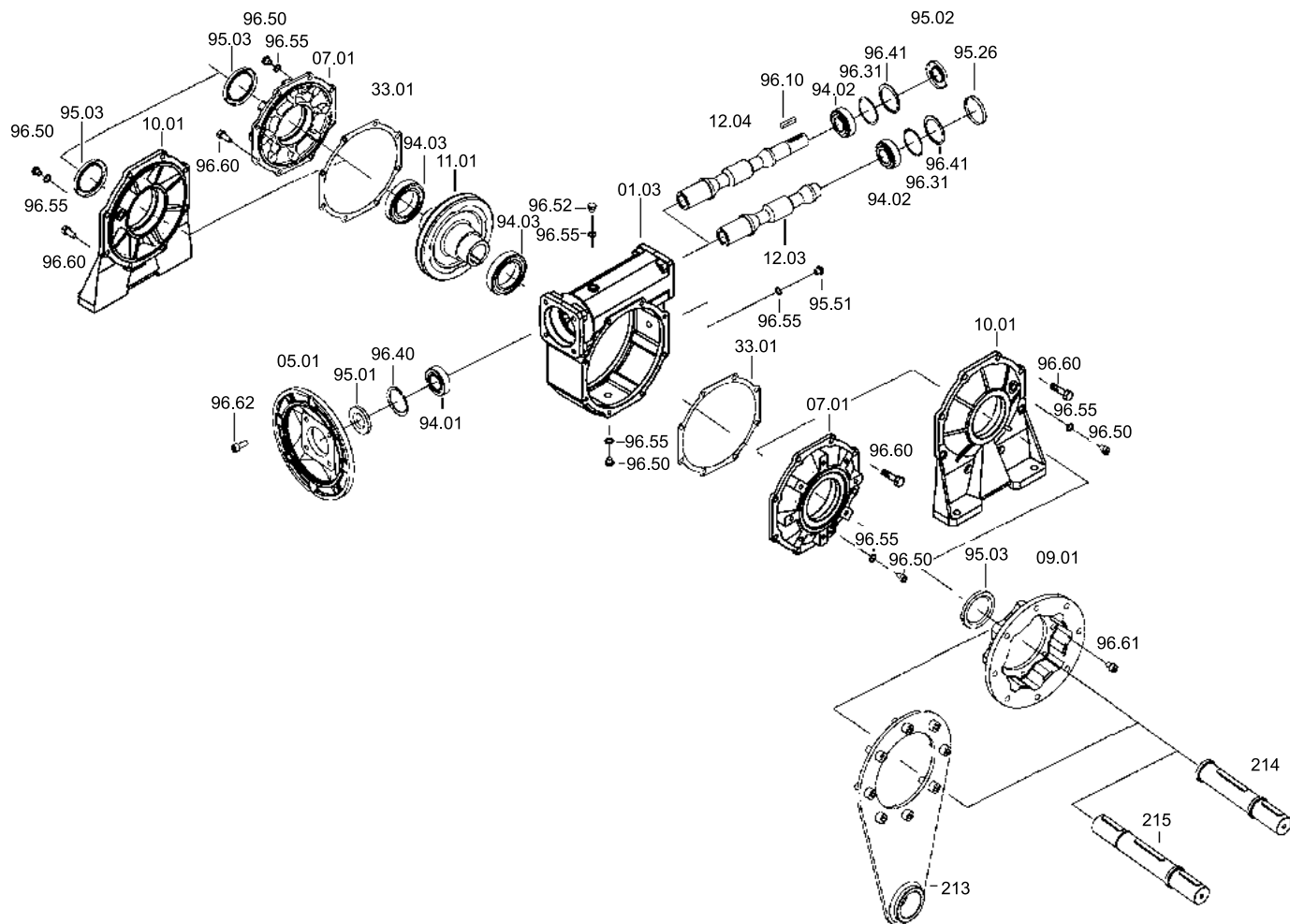

KC	IEC	Cuscinetti / Bearings / Lager				Anelli di tenuta / Oilseals Öldichtungen			Cappellotto / Closed oil seal Geschlossene Öldichtung		
		94.01	94.02	94.03		95.01	95.02	95.03	95.26		
30	56	61804 (20x32x7)	6000	6005	*32005	20/32/7	10/26/7	25/40/7	ø 26x7		
	63	61804 (20x32x7)	10x26x8	25x47x12	25x47x15	20/32/7					
40	56	6303 (17x47x14)	6201	6006	*32006	17/47/7	12/32/7	30/47/7	ø 32x7		
	63	6204 (20x47x14)				30x55x13				30x55x17	
	71	6005 (25x47x12)				25/47/7					
50	63	6204 (20x47x14)	6203	6008	*32008	20/47/7	17/40/7	40/62/8	ø 40x7		
	71	6005 (25x47x12)				40x68x15				40x68x19	
	80	6006 (30x55x13)				30/55/7					
63	71	30305 (25x62x18.25)	30204	6008	*32008	25/62/7	20/47/7	40/62/8	ø 47x7		
	80	30206 (30x62x17.25)				40x68x15				40x68x19	
	90	32007 (35x62x18)				30/62/7					
75	80	30206 (30x62x17.25)	30205	6010	*32010	30/62/7	25/52/7	50/72/8	ø 52x7		
	90	32007 (35x62x18)				50x80x16				50x80x20	
	100/112	32008 (40x68x19)				40/68/10					
90	80	30206 (30x62x17.25)	32205B	6010	*32010	30/62/7	25/52/7	50/72/8	ø 52x7		
	90	32007 (35x62x18)				25x52x19.25				50x80x16	50x80x20
	100/112	32008 (40x68x19)				40/68/10					
110	90	30208 (40x80x19.75)	32206B	6012	*32012	40/80/10	30/62/7	60/85/8	ø 62x7		
	100/112	30208 (40x80x19.75)				30x62x21.25				60x95x18	60x95x23
	132	32010 (50x80x20)				50/80/10					
130	90	30208 (40x80x19.75)	33208	6015	*32015	40/80/10	40/80/10	75/100/10	ø 80x10		
	100/112	30208 (40x80x19.75)				40x80x32				75x115x20	75x115x25
	132	32010 (50x80x20)				50/80/10					

* Cuscinetti a rulli conici a richiesta - Tapered roller bearings on request - Auf Wunsch Kegelrollenlager

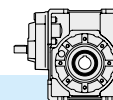

4.0	RIDUTTORI A VITE SENZA FINE CON PRECOPPIA H	H HELICAL WORM GEARBOXES	STIRNRAD- SCHNECKENGETRIEBE H	
4.1	Caratteristiche	<i>Characteristics</i>	Merkmale	64
4.2	Designazione	<i>Designation</i>	Bezeichnung	65
4.3	Lubrificazione e posizioni di montaggio	<i>Lubrication and mounting position</i>	Schmierung und Einbaulage	66
4.4	Posizione morsettiera	<i>Terminal board position</i>	Lage der Klemmbrett	66
4.5	Dati tecnici	<i>Technical data</i>	Technische Daten	67
4.6	Momenti d'inerzia	<i>Moments of inertia</i>	Trägheitsmoment	74
4.7	Dimensioni	<i>Dimensions</i>	Abmessungen	76
4.8	Esecuzione con vite bisporgente	<i>Double extended worm shaft design</i>	Versioni con doppiamente protrudende Schneckenwelle	80
4.9	Limitatore di coppia cavo passante	<i>Torque limiter with through hollow shaft</i>	Drehmomentbegrenzer mit durchgehender Hohlwelle	80
4.10	Accessori	<i>Accessories</i>	Zubehör	82
4.11	Lista parti di ricambio	<i>Spare parts list</i>	Ersatzteilliste	83

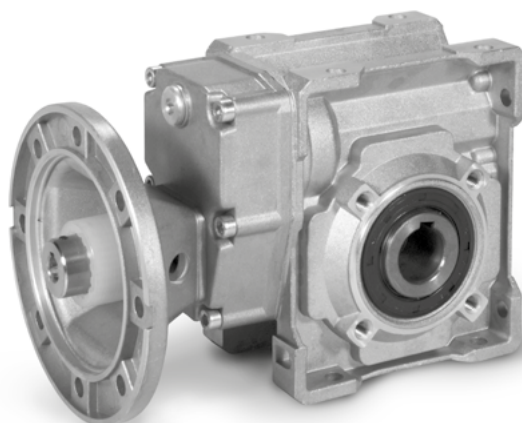

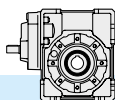

4.1 Caratteristiche

- La serie H presenta le stesse caratteristiche della serie X, ma la presenza della precoppia cilindrica in entrata consente la realizzazione di rapporti più elevati o, a parità di rapporto, rendimenti migliori.
- La struttura è composta dalla carcassa monoblocco del riduttore a vite serie XA sull'entrata del quale è fissato il corpo contenente il primo stadio di riduzione.
- La vite senza fine è in acciaio legato cementato-temprato ed è rettificata.
- Gli ingranaggi della prima riduzione hanno dentatura elicoidale con profilo rettificato.
- La corona ha il mozzo in ghisa con riporto di fusione dell'anello in bronzo.
- Viene fornito l'albero uscita cavo di serie ed esiste un'ampia disponibilità di accessori: seconda entrata, cuscinetti conici sulla corona, flangia uscita, albero lento con 1 o 2 sporgenze, limitatore di coppia con cavo passante, braccio di reazione.
- Le carcasse in ghisa sono verniciate BLU RAL5010 mentre quelle in alluminio sono sabbiate.

4.1 Characteristics

- *The H series has the same characteristics as the X series with the addition of a spur gear pre-stage at input which provides higher ratios or better efficiency under the same ratios.*
- *The structure is composed of a single piece housing for the XA gearbox, at the input side of this gearbox is fitted the housing containing the first stage reduction.*
- *The worm shaft is in case and quenched alloy steel and ground.*
- *The gears of the first reduction have a helical toothing with ground profile.*
- *The worm wheel has a cast-iron hub provided with inserted cast-bronze ring.*
- *Hollow output shaft is supplied as standard. A broad range of accessories is available: second input, tapered roller bearings on the worm wheel, output flange, single or double extended output shaft, torque limiter with through hollow shaft.*
- *Housings in cast-iron are painted BLUE RAL5010, whereas those in aluminium are sandblasted.*

4.1 Merkmale

- Die Serie H bietet die gleichen Eigenschaften wie die Serie X. Aufgrund der Stirnrad-Vorstufe bei der Serie H sind jedoch höhere Untersetzungen möglich oder man erhält bei gleichen Untersetzungen einen besseren Wirkungsgrad.
- Diese Ausführung besteht aus dem Blockgehäuse des Schneckengetriebes der Serie XA und einem an den antriebsseitig angebauten Gehäuse, welches die Stirnradvorstufe enthält.
- Die Schnecke ist aus einsatzgehärtetem/abgeschrecktem und daraufhin geschliffenen Legierungsstahl.
- Die Zahnräder der Vorstufe besitzen ein schrägverzahntes Stirnradprofil.
- Das Schneckenrad besteht aus einer Nabe aus Gusseisen und einem aufgeschleuderten Gussbronze-Ring.
- Zahlreiches Zubehör ist lieferbar: zweite Antrieb, Kegelrollenlager auf Schneckenrad, Abtriebsflansch, Standard oder doppelseitig herausragende Abtriebswelle, Drehmomentbegrenzer mit durchgehender Welle, Drehmomentstütze.
- Gehäuse aus Gusseisen werden mit BLAU RAL5010 lackiert, Gehäuse aus Aluminium werden sandgestrahlt.

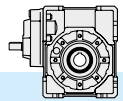

4.2 Designazione

4.2 Designation

4.2 Bezeichnung

Riduttore Gearbox Getriebe	Tipo entrata Input type Antriebsart	Grandezza Size Größe	Rapporto rid. Ratio Untersetzung	Predispos. att. mot. Motor coupling Motoranschluss	Posizione di mont. Mounting position Einbaulage	Flangia in uscita. Output flange Abtriebsflansch	Limitatore di coppia. Torque limiter Drehmomentbegrenzer	Seconda entrata Additional input Zusatzantrieb	Albero uscita Output shaft Abtriebswelle	Braccio di reazione Torque arm Drehmomentstütze
H	A	50	30/1	P.A.M	B3	F1S	LD	SeA	H	BR
Riduttore a vite senza fine Wormgearbox Schneckengetriebe	A F	40 50 63 75 90 110 130	30 40 60 80 100 120 160 200 260 320 400	56 63 71 80 90 100 112	B3, B6 B7, B8 V5, V6	 F1D-F2D-F3D F1S-F2S-F3S F12-F22-F32	 LD LS	 SeA	 H SD SS DD	 BR

Tipo entrata

Input type

Antriebstyp

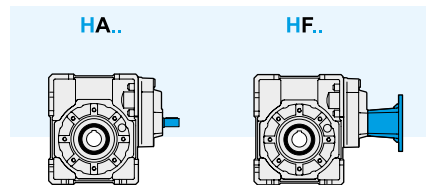

4.3 Lubrificazione e posizioni di montaggio

4.3 Lubrication and mounting position

4.3 Schmierung und Einbaulage

I riduttori a vite senza fine H sono forniti completi di lubrificante sintetico a base PAG con indice di viscosità ISO VG320. Si raccomanda di precisare sempre in fase di ordine, la posizione di lavoro desiderata.

H worm gearboxes are supplied with PAG synthetic lubricant featuring an ISO VG320 viscosity class. Always specify the required mounting position when ordering.

Schneckengetriebe der Serie H werden mit synthetischem Schmiermittel auf PAG Basis und Viskosität Index ISO VG320 geliefert. Im Auftrag bitte immer die gewünschte Einbaulage angeben.

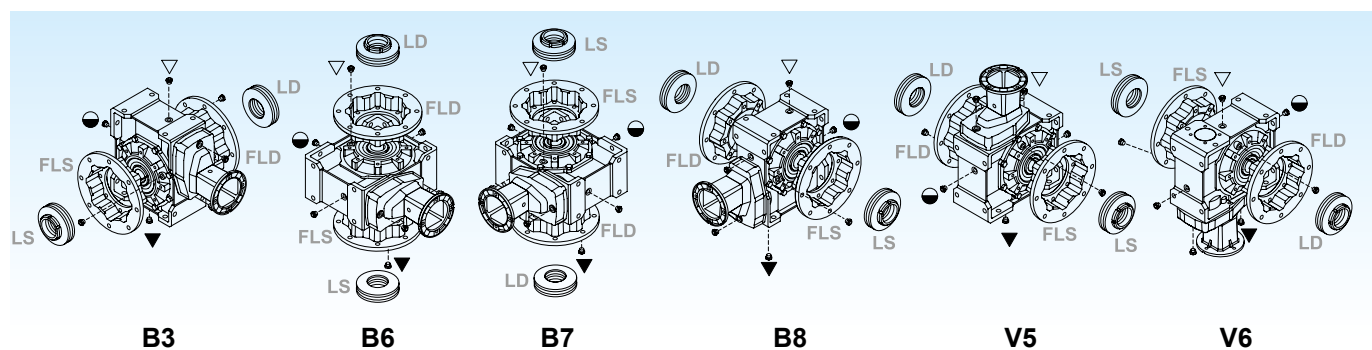

- ▽ Carico e sfiato / Filling and breather
Einfüll und Entlüftung
- Livello / Level / Ölstand
- ▼ Scarico / Drain / Ablass

Nei corpi in alluminio 40, 50, 63,75 è presente un solo tappo di riempimento olio.

Aluminium housings size 40, 50, 63 and 75 have one filling plug only.

Aluminiumgehäuse in den Größen 40, 50, 63 und 75 verfügen über Einfüllungsschraube.

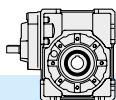

4.3 Lubrificazione e posizioni di montaggio

4.3 Lubrication and mounting position

4.3 Schmierung und Einbaulage

HA
HF V5

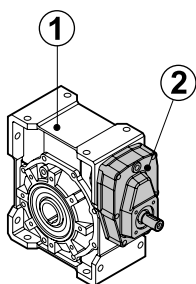
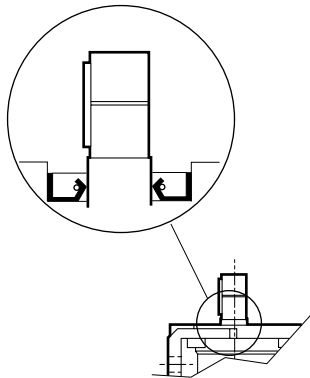
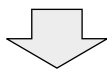

Attenzione! Nelle versioni HA e HF è indispensabile conoscere la posizione di lavoro in quanto nella configurazione V5 occorre posizionare in modo corretto il paraolio della vite per preservare la corretta lubrificazione della coppia d'ingranaggi cilindrici del primo stadio di riduzione.

Warning! It is fundamental to specify the mounting position specially when ordering HA and HF versions. This is because in the V5 configuration the oil seal on the worm shaft must be positioned properly to ensure the lubrication of the spur gearset of the first reduction stage.

Achtung! Bei den HA und HF Versionen ist die Information bez. die Einbaulage unbedingt erforderlich: in der V5 Bauform muss der Ölabdichtung auf der Schnecke korrekt eingebaut werden, um die Schmierung des Stirnradsatz der ersten Stufe aufrechtzuhalten.

		Q.tà olio / Oil quantity / Schmiermittelmenge [lt]			
		Posizione di montaggio / Mounting position / Einbaulage			
		B3	B6 - B7	B8	V5 - V6
① H	40	0.040	0.060	0.040	
	50	0.080	0.120	0.080	
	63	0.160	0.220	0.160	
	75	0.260	0.340	0.260	
	90	1.1	0.9	1	1.5
	110	2.2	1.8	1.6	2.6
	130	3.6	3	2.5	3.8
		B3	B6	B8	V5
② H	40	0.040			
	50	0.052			
	63	0.095			
	75	0.180			
	90	0.180			
	110	0.250			
	130	0.350			

Specificare sempre in fase di ordinazione la posizione di montaggio e la forma costruttiva.

Posizione morsetteria v. pag. 81 (PM=1; PM=2)

Mounting position always to be specified when ordering.

Terminal board position see page 81 (PM=1; PM=2)

Bei der Bestellung immer die gewünschte Montageposition und Bauform angeben.

Lage der Klemmenkaste Seite 81 (PM=1; PM=2)

4.4 Posizione morsetteria

4.4 Terminal board position

4.4 Lage der Klemmenkaste

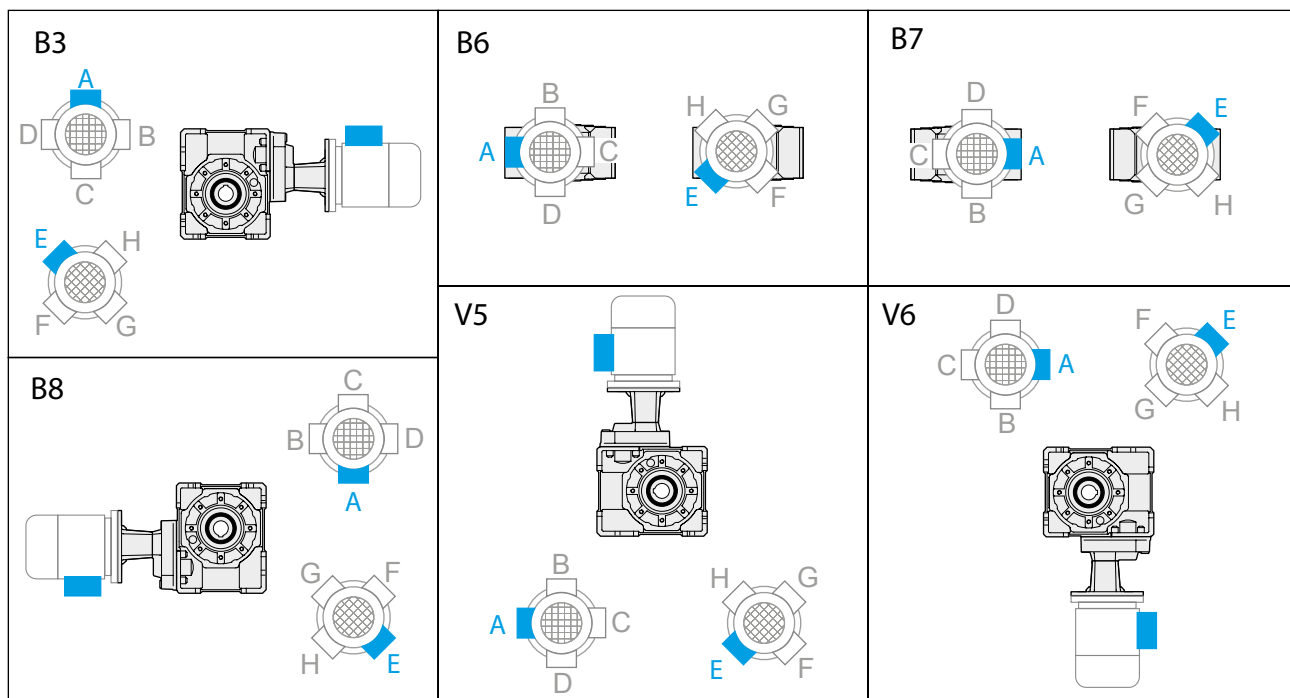

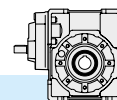

4.5 Dati tecnici

4.5 Technical data

4.5 Technische Daten

40	n₁ = 2800				HA			HF							
	i _n	n ₂ [min ⁻¹]	Rd	P _{t0}	T _{2M} [Nm]	P [kW]	T ₂ [Nm]	P ₁ [kW]	FS'	Input - IEC		B14			
										B5	IEC	B5	B14		
Kg 2.9	30	93	0.80	—	52	0.64	30	0.37	1.7	—	63	56	—	63	56
	40	70	0.77		53	0.50	39	0.37	1.4						
	60	47	0.72		53	0.36	37	0.25	1.4						
	80	35	0.70		50	0.26	47	0.25	1.1						
	100	28	0.65		44	0.20	40	0.18	1.1						
	120	23	0.61		55	0.22	45	0.18	1.2						
	160	18	0.57		52	0.17	40	0.13	1.3						
	200	14	0.51		47	0.13	47	0.13	1.0						
	260	11	0.47		42	0.10	38	0.09	1.1						
	320	9	0.45		39	0.08	44	0.09	0.9						
400	7	0.42	31	0.05	52*	0.09	0.6*								

40	n₁ = 1400				HA			HF							
	i _n	n ₂ [min ⁻¹]	Rd	P _{t0}	T _{2M} [Nm]	P [kW]	T ₂ [Nm]	P ₁ [kW]	FS'	Input - IEC		B14			
										B5	IEC	B5	B14		
Kg 2.9	30	47	0.77	0.60	65	0.41	35	0.22	1.9	—	63	56	—	63	56
	40	35	0.75	0.60	65	0.32	45	0.22	1.5						
	60	23	0.69	0.50	62	0.23	62	0.22	1.0						
	80	18	0.66	0.40	60	0.17	47	0.13	1.3						
	100	14	0.61	0.40	52	0.12	46	0.11	1.1						
	120	12	0.57	0.30	66	0.14	60	0.13	1.1						
	160	9	0.52	0.30	62	0.11	62	0.11	1.0						
	200	7	0.47	0.30	58	0.09	58	0.09	1.0						
	260	5	0.43	0.20	46	0.06	46	0.06	1.1						
	320	4	0.41	0.20	44	0.05	53	0.06	0.8						
400	3	0.38	0.20	33	0.03	64*	0.06	0.5*							

40	n₁ = 900				HA			HF							
	i _n	n ₂ [min ⁻¹]	Rd	P _{t0}	T _{2M} [Nm]	P [kW]	T ₂ [Nm]	P ₁ [kW]	FS'	Input - IEC		B14			
										B5	IEC	B5	B14		
Kg 2.9	30	30	0.76	—	66	0.27	31	0.13	2.1	—	63	56	—	63	56
	40	23	0.73		66	0.21	40	0.13	1.6						
	60	15	0.67		66	0.15	56	0.13	1.2						
	80	11	0.64		66	0.12	49	0.09	1.3						
	100	9	0.59		58	0.09	58	0.09	1.0						
	120	8	0.54		66	0.10	62	0.09	1.1						
	160	6	0.50		66	0.08	51	0.06	1.3						
	200	5	0.44		61	0.06	57	0.06	1.1						
	260	4	0.40		54	0.05	33	0.03	1.6						
	320	3	0.39		46	0.03	39	0.03	1.2						
400	2	0.36	34	0.02	46*	0.03	0.7*								

40	n₁ = 500				HA			HF							
	i _n	n ₂ [min ⁻¹]	Rd	P _{t0}	T _{2M} [Nm]	P [kW]	T ₂ [Nm]	P ₁ [kW]	FS'	Input - IEC		B14			
										B5	IEC	B5	B14		
Kg 2.9	30	17	0.74	—	66	0.15	—	—	—	—	63	56	—	63	56
	40	13	0.71		66	0.12	—	—	—						
	60	8	0.66		66	0.09	—	—	—						
	80	6	0.62		66	0.07	—	—	—						
	100	5	0.57		66	0.06	—	—	—						
	120	4	0.52		66	0.06	—	—	—						
	160	3	0.48		66	0.04	—	—	—						
	200	2.5	0.42		66	0.04	—	—	—						
	260	2	0.38		60	0.03	—	—	—						
	320	1.5	0.36		48	0.02	—	—	—						
400	1	0.34	35	0.01	—	—	—								

* **ATTENZIONE:** la coppia massima utilizzabile [T_{2M}] deve essere calcolata utilizzando il fattore di servizio: T_{2M} = T₂ x FS'

* **WARNING:** Maximum allowable torque [T_{2M}] must be calculated using the following service factor: T_{2M} = T₂ x FS'

* **ACHTUNG:** das max. anwendbare Drehmoment [T_{2M}] muss mit folgendem Betriebsfaktor berechnet werden: T_{2M} = T₂ x FS'

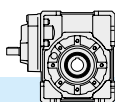

4.5 Dati tecnici

4.5 Technical data

4.5 Technische Daten

50	n₁ = 2800			HA			HF								
	i _n	n ₂ [min ⁻¹]	Rd	P _{t0}	T _{2M} [Nm]	P [kW]	T ₂ [Nm]	P ₁ [kW]	FS'	Input - IEC			B14		
										B5					
 4.7	30	93	0.81	—	91	1.10	62	0.75	1.5	71	63	56	71	63	—
	40	70	0.79		94	0.87	81	0.75	1.2						
	60	47	0.74		96	0.63	84	0.55	1.1						
	80	35	0.72		94	0.48	72	0.37	1.3						
	100	28	0.68		81	0.35	58	0.25	1.4						
	120	23	0.64		96	0.37	96	0.37	1.0						
	160	18	0.60		97	0.30	81	0.25	1.2						
	200	14	0.55		86	0.23	67	0.18	1.3						
	260	11	0.51		81	0.18	81	0.18	1.0						
	320	9	0.47		72	0.14	67	0.13	1.1						
400	7	0.44	59	0.10	54	0.09	1.1								

50	n₁ = 1400			HA			HF								
	i _n	n ₂ [min ⁻¹]	Rd	P _{t0}	T _{2M} [Nm]	P [kW]	T ₂ [Nm]	P ₁ [kW]	FS'	Input - IEC			B14		
										B5					
 4.7	30	47	0.79	0.90	113	0.70	88	0.55	1.3	71	63	56	71	63	—
	40	35	0.76	0.80	116	0.56	116	0.55	1.0						
	60	23	0.71	0.70	116	0.40	108	0.37	1.1						
	80	18	0.68	0.60	114	0.31	93	0.25	1.2						
	100	14	0.63	0.50	97	0.22	97	0.22	1.0						
	120	12	0.59	0.50	107	0.22	107	0.22	1.0						
	160	9	0.55	0.40	115	0.19	108	0.18	1.1						
	200	7	0.50	0.40	102	0.15	89	0.13	1.1						
	260	5	0.46	0.40	90	0.11	90	0.11	1.0						
	320	4	0.42	0.30	83	0.09	83	0.09	1.0						
400	3	0.40	0.30	65	0.06	65	0.06	0.9							

50	n₁ = 900			HA			HF								
	i _n	n ₂ [min ⁻¹]	Rd	P _{t0}	T _{2M} [Nm]	P [kW]	T ₂ [Nm]	P ₁ [kW]	FS'	Input - IEC			B14		
										B5					
 4.7	30	30	0.77	—	116	0.47	91	0.37	1.3	71	63	56	71	63	—
	40	23	0.75		116	0.37	116	0.37	1.0						
	60	15	0.69		116	0.26	110	0.25	1.1						
	80	11	0.66		116	0.21	101	0.18	1.2						
	100	9	0.61		108	0.17	85	0.13	1.3						
	120	8	0.57		116	0.16	94	0.13	1.3						
	160	6	0.53		116	0.13	116	0.13	1.0						
	200	5	0.48		112	0.11	91	0.09	1.2						
	260	4	0.44		107	0.09	107	0.09	1.0						
	320	3	0.40		90	0.07	82	0.06	1.1						
400	2	0.38	65	0.04	48	0.03	1.4								

50	n₁ = 500			HA			HF								
	i _n	n ₂ [min ⁻¹]	Rd	P _{t0}	T _{2M} [Nm]	P [kW]	T ₂ [Nm]	P ₁ [kW]	FS'	Input - IEC			B14		
										B5					
 4.7	30	17	0.76	—	116	0.27	39	0.09	3.0	71	63	56	71	63	—
	40	13	0.73		116	0.21	50	0.09	2.3						
	60	8	0.67		116	0.15	69	0.09	1.7						
	80	6	0.64		116	0.12	88	0.09	1.3						
	100	5	0.59		116	0.10	101	0.09	1.1						
	120	4	0.54		116	0.09	112	0.09	1.0						
	160	3	0.50		116	0.08	138*	0.09	0.8						
	200	2.5	0.45		116	0.07	156*	0.09	0.7						
	260	2	0.41		114	0.06	184*	0.09	0.6*						
	320	1.5	0.38		95	0.04	208*	0.09	0.5*						
400	1	0.35	69	0.03	244*	0.09	0.3*								

* **ATTENZIONE:** la coppia massima utilizzabile [T_{2M}] deve essere calcolata utilizzando il fattore di servizio: T_{2M} = T₂ x FS'

* **WARNING:** Maximum allowable torque [T_{2M}] must be calculated using the following service factor: T_{2M} = T₂ x FS'

* **ACHTUNG:** das max. anwendbare Drehmoment [T_{2M}] muss mit folgendem Betriebsfaktor berechnet werden: T_{2M} = T₂ x FS'

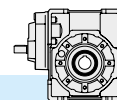

4.5 Dati tecnici

4.5 Technical data

4.5 Technische Daten

63	$n_1 = 2800$			HA					HF							
	i_n	n_2 [min ⁻¹]	Rd	P_{t0}	T_{2M} [Nm]	P [kW]	T_2 [Nm]	P_1 [kW]	FS'	Input - IEC			B14			
											B5					
Kg 7.9	30	93	0.82	—	158	1.89	126	1.5	1.3	80	71	63	80	71	—	
	40	70	0.80		164	1.50	164	1.5								1.0
	60	47	0.76		170	1.10	170	1.1								1.0
	80	35	0.74		181	0.90	151	0.75								1.2
	100	28	0.71		150	0.62	133	0.55								1.1
	120	23	0.66		177	0.66	148	0.55								1.2
	160	18	0.62		186	0.55	186	0.55								1.0
	200	14	0.57		147	0.37	147	0.37								1.0
	260	11	0.53		142	0.30	118	0.25								1.2
	320	9	0.51		138	0.25	138	0.25								1.0
400	7	0.46	115	0.18	115	0.18	1.0									

63	$n_1 = 1400$			HA					HF							
	i_n	n_2 [min ⁻¹]	Rd	P_{t0}	T_{2M} [Nm]	P [kW]	T_2 [Nm]	P_1 [kW]	FS'	Input - IEC			B14			
											B5					
Kg 7.9	30	47	0.79	1.3	198	1.22	146	0.9	1.4	80	71	63	80	71	—	
	40	35	0.77		203	0.96	190	0.9								1.1
	60	23	0.72		203	0.69	163	0.55								1.2
	80	18	0.70		211	0.55	211	0.55								1.0
	100	14	0.67		181	0.40	169	0.37								1.1
	120	12	0.61		213	0.43	185	0.37								1.1
	160	9	0.57		220	0.35	156	0.25								1.4
	200	7	0.52		177	0.25	177	0.25								1.0
	260	5	0.48		175	0.20	154	0.18								1.1
	320	4	0.46		160	0.16	130	0.13								1.2
400	3	0.41	126	0.11	150	0.13	0.8									

63	$n_1 = 900$			HA					HF							
	i_n	n_2 [min ⁻¹]	Rd	P_{t0}	T_{2M} [Nm]	P [kW]	T_2 [Nm]	P_1 [kW]	FS'	Input - IEC			B14			
											B5					
Kg 7.9	30	30	0.78	—	220	0.89	186	0.75	1.2	80	71	63	80	71	—	
	40	23	0.76		220	0.69	177	0.55								1.2
	60	15	0.70		220	0.49	166	0.37								1.3
	80	11	0.68		220	0.37	220	0.37								1.0
	100	9	0.65		201	0.29	172	0.25								1.2
	120	8	0.59		220	0.29	187	0.25								1.2
	160	6	0.55		220	0.24	168	0.18								1.3
	200	5	0.50		196	0.18	196	0.18								1.0
	260	4	0.46		192	0.15	162	0.13								1.2
	320	3	0.43		175	0.12	133	0.09								1.3
400	2	0.39	131	0.08	148	0.09	0.9									

63	$n_1 = 500$			HA					HF							
	i_n	n_2 [min ⁻¹]	Rd	P_{t0}	T_{2M} [Nm]	P [kW]	T_2 [Nm]	P_1 [kW]	FS'	Input - IEC			B14			
											B5					
Kg 7.9	30	17	0.76	—	220	0.50	79	0.18	2.8	80	71	63	80	71	—	
	40	13	0.74		220	0.39	101	0.18								2.2
	60	8	0.68		220	0.28	140	0.18								1.6
	80	6	0.66		220	0.22	182	0.18								1.2
	100	5	0.62		220	0.18	220	0.18								1.0
	120	4	0.56		220	0.17	115	0.09								1.9
	160	3	0.52		220	0.14	143	0.09								1.5
	200	2.5	0.47		220	0.12	161	0.09								1.4
	260	2	0.43		215	0.10	193	0.09								1.1
	320	1.5	0.41		188	0.08	225	0.09								0.8
400	1	0.36	138	0.05	250*	0.09	0.6*									

* **ATTENZIONE:** la coppia massima utilizzabile $[T_{2M}]$ deve essere calcolata utilizzando il fattore di servizio: $T_{2M} = T_2 \times FS'$

* **WARNING:** Maximum allowable torque $[T_{2M}]$ must be calculated using the following service factor: $T_{2M} = T_2 \times FS'$

* **ACHTUNG:** das max. anwendbare Drehmoment $[T_{2M}]$ muss mit folgendem Betriebsfaktor berechnet werden: $T_{2M} = T_2 \times FS'$

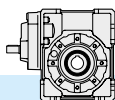

4.5 Dati tecnici

4.5 Technical data

4.5 Technische Daten

75	n₁ = 2800			HA					HF						
	i _n	n ₂ [min ⁻¹]	Rd	P _{t0}	T _{2M} [Nm]	P [kW]	T ₂ [Nm]	P ₁ [kW]	FS'	Input - IEC			B14		
										B5					
Kg 13.3	30	93	0.82	—	236	2.81	185	2.2	1.3	90	80	71	90	80	—
	40	70	0.80		242	2.20	242	2.2	1.0						
	60	47	0.77		258	1.65	235	1.5	1.1						
	80	35	0.74		285	1.40	223	1.1	1.3						
	100	28	0.72		252	1.03	184	0.75	1.4						
	120	23	0.67		275	1.01	205	0.75	1.3						
	160	18	0.63		290	0.84	259	0.75	1.1						
	200	14	0.60		258	0.63	224	0.55	1.2						
	260	11	0.55		236	0.48	181	0.37	1.3						
	320	9	0.52		214	0.37	214	0.37	1.0						
400	7	0.48	195	0.30	241	0.37	0.8								

75	n₁ = 1400			HA					HF						
	i _n	n ₂ [min ⁻¹]	Rd	P _{t0}	T _{2M} [Nm]	P [kW]	T ₂ [Nm]	P ₁ [kW]	FS'	Input - IEC			B14		
										B5					
Kg 13.3	30	47	0.80	1.9	295	1.80	295	1.8	1.0	90	80	71	90	80	—
	40	35	0.78	1.7	319	1.50	319	1.5	1.0						
	60	23	0.73	1.4	329	1.10	329	1.1	1.0						
	80	18	0.71	1.3	350	0.90	350	0.9	1.0						
	100	14	0.68	1.2	305	0.66	255	0.55	1.2						
	120	12	0.62	1.0	331	0.65	280	0.55	1.2						
	160	9	0.58	0.90	348	0.55	348	0.55	1.0						
	200	7	0.55	0.80	307	0.41	277	0.37	1.1						
	260	5	0.50	0.80	279	0.31	223	0.25	1.3						
	320	4	0.47	0.70	256	0.25	256	0.25	1.0						
400	3	0.43	0.70	213	0.18	300*	0.25	0.7*							

75	n₁ = 900			HA					HF						
	i _n	n ₂ [min ⁻¹]	Rd	P _{t0}	T _{2M} [Nm]	P [kW]	T ₂ [Nm]	P ₁ [kW]	FS'	Input - IEC			B14		
										B5					
Kg 13.3	30	30	0.78	—	338	1.35	275	1.1	1.2	90	80	71	90	80	—
	40	23	0.76		350	1.10	350	1.1	1.0						
	60	15	0.71		343	0.75	343	0.75	1.0						
	80	11	0.69		350	0.60	321	0.55	1.1						
	100	9	0.66		339	0.49	258	0.37	1.3						
	120	8	0.60		350	0.46	281	0.37	1.2						
	160	6	0.56		350	0.37	350	0.37	1.0						
	200	5	0.52		339	0.31	277	0.25	1.2						
	260	4	0.48		307	0.24	233	0.18	1.3						
	320	3	0.45		282	0.18	282	0.18	1.0						
400	2	0.40	221	0.13	307*	0.18	0.7*								

75	n₁ = 500			HA					HF						
	i _n	n ₂ [min ⁻¹]	Rd	P _{t0}	T _{2M} [Nm]	P [kW]	T ₂ [Nm]	P ₁ [kW]	FS'	Input - IEC			B14		
										B5					
Kg 13.3	30	17	0.77	—	350	0.80	110	0.25	3.2	90	80	71	90	80	—
	40	13	0.74		350	0.62	142	0.25	2.5						
	60	8	0.69		350	0.44	198	0.25	1.8						
	80	6	0.67		350	0.34	254	0.25	1.4						
	100	5	0.63		350	0.29	303	0.25	1.2						
	120	4	0.57		350	0.27	325	0.25	1.1						
	160	3	0.53		350	0.22	291	0.18	1.2						
	200	2.5	0.49		350	0.19	348	0.18	1.0						
	260	2	0.45		345	0.16	200	0.09	1.7						
	320	1.5	0.42		303	0.12	231	0.09	1.3						
400	1	0.38	232	0.08	258	0.09	0.9								

* **ATTENZIONE:** la coppia massima utilizzabile [T_{2M}] deve essere calcolata utilizzando il fattore di servizio: T_{2M} = T₂ x FS'

* **WARNING:** Maximum allowable torque [T_{2M}] must be calculated using the following service factor: T_{2M} = T₂ x FS'

* **ACHTUNG:** das max. anwendbare Drehmoment [T_{2M}] muss mit folgendem Betriebsfaktor berechnet werden: T_{2M} = T₂ x FS'

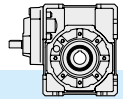

4.5 Dati tecnici

4.5 Technical data

4.5 Technische Daten

90	n₁ = 2800				HA					HF					
	i _n	n ₂ [min ⁻¹]	Rd	P _{t0}	T _{2M} [Nm]	P [kW]	T ₂ [Nm]	P ₁ [kW]	FS'	Input - IEC			B14		
										B5					
 27.2	30	93	0.83	—	381	4.48	255	3	1.5	90	80	71	90	80	—
	40	70	0.82		396	3.56	334	3	1.2						
	60	47	0.78		410	2.57	352	2.2	1.2						
	80	35	0.76		456	2.20	456	2.2	1.0						
	100	28	0.74		416	1.66	377	1.5	1.1						
	120	23	0.69		439	1.54	439	1.5	1.0						
	160	18	0.65		467	1.31	392	1.1	1.2						
	200	14	0.62		427	1.01	317	0.75	1.3						
	260	11	0.58		384	0.75	384	0.75	1.0						
	320	9	0.55		360	0.60	329	0.55	1.1						
400	7	0.50	318	0.47	252	0.37	1.3								

90	n₁ = 1400				HA					HF					
	i _n	n ₂ [min ⁻¹]	Rd	P _{t0}	T _{2M} [Nm]	P [kW]	T ₂ [Nm]	P ₁ [kW]	FS'	Input - IEC			B14		
										B5					
 27.2	30	47	0.81	2.1	482	2.92	297	1.8	1.6	90	80	71	90	80	—
	40	35	0.79	1.9	495	2.30	388	1.8	1.3						
	60	23	0.75	1.6	506	1.65	460	1.5	1.1						
	80	18	0.72	1.4	554	1.40	434	1.1	1.3						
	100	14	0.70	1.3	505	1.06	429	0.9	1.2						
	120	12	0.64	1.1	531	1.01	473	0.9	1.1						
	160	9	0.60	1.0	560	0.85	494	0.75	1.1						
	200	7	0.57	0.90	510	0.66	428	0.55	1.2						
	260	5	0.53	0.80	454	0.49	345	0.37	1.3						
	320	4	0.50	0.80	424	0.39	402	0.37	1.1						
400	3	0.45	0.70	367	0.29	314	0.25	1.2							

90	n₁ = 900				HA					HF					
	i _n	n ₂ [min ⁻¹]	Rd	P _{t0}	T _{2M} [Nm]	P [kW]	T ₂ [Nm]	P ₁ [kW]	FS'	Input - IEC			B14		
										B5					
 27.2	30	30	0.79	—	550	2.18	379	1.5	1.5	90	80	71	90	80	—
	40	23	0.77		560	1.71	492	1.5	1.1						
	60	15	0.73		560	1.21	510	1.1	1.1						
	80	11	0.70		560	0.94	447	0.75	1.3						
	100	9	0.68		560	0.78	534	0.75	1.1						
	120	8	0.61		560	0.72	430	0.55	1.3						
	160	6	0.58		560	0.57	533	0.55	1.1						
	200	5	0.54		560	0.49	426	0.37	1.3						
	260	4	0.50		501	0.37	501	0.37	1.0						
	320	3	0.47		466	0.29	399	0.25	1.2						
400	2	0.42	381	0.21	320	0.18	1.2								

90	n₁ = 500				HA					HF					
	i _n	n ₂ [min ⁻¹]	Rd	P _{t0}	T _{2M} [Nm]	P [kW]	T ₂ [Nm]	P ₁ [kW]	FS'	Input - IEC			B14		
										B5					
 27.2	30	17	0.77	—	560	1.26	111	0.25	5.0	90	80	71	90	80	—
	40	13	0.75		560	0.97	144	0.25	3.9						
	60	8	0.70		560	0.69	202	0.25	2.8						
	80	6	0.68		560	0.54	259	0.25	2.2						
	100	5	0.65		560	0.45	310	0.25	1.8						
	120	4	0.58		560	0.42	334	0.25	1.7						
	160	3	0.54		560	0.34	416	0.25	1.3						
	200	2.5	0.51		560	0.29	488	0.25	1.1						
	260	2	0.47		560	0.24	417	0.18	1.3						
	320	1.5	0.44		517	0.19	485	0.18	1.1						
400	1	0.39	401	0.13	269	0.09	1.5								

* **ATTENZIONE:** la coppia massima utilizzabile [T_{2M}] deve essere calcolata utilizzando il fattore di servizio: T_{2M} = T₂ x FS'

* **WARNING:** Maximum allowable torque [T_{2M}] must be calculated using the following service factor: T_{2M} = T₂ x FS'

* **ACHTUNG:** das max. anwendbare Drehmoment [T_{2M}] muss mit folgendem Betriebsfaktor berechnet werden: T_{2M} = T₂ x FS'

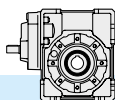

4.5 Dati tecnici

4.5 Technical data

4.5 Technische Daten

110	n₁ = 2800			HA					HF						
	i _n	n ₂ [min ⁻¹]	Rd	P _{t0}	T _{2M} [Nm]	P [kW]	T ₂ [Nm]	P ₁ [kW]	FS'	Input - IEC					
										B5			B14		
48.8	30	93	0.84	—	641	7.50	641	7.5	1.0	112 100	90	80	112 100	90	—
	40	70	0.82		658	5.85	619	5.5	1.1						
	60	47	0.79		698	4.30	649	4	1.1						
	80	35	0.77		782	3.71	632	3	1.2						
	100	28	0.75		727	2.83	566	2.2	1.3						
	120	23	0.70		754	2.61	634	2.2	1.2						
	160	18	0.67		807	2.20	807	2.2	1.0						
	200	14	0.65		749	1.70	661	1.5	1.1						
	260	11	0.60		646	1.21	589	1.1	1.1						
	320	9	0.57		611	0.98	469	0.75	1.3						
400	7	0.53	545	0.75	545	0.75	1.0								

110	n₁ = 1400			HA					HF						
	i _n	n ₂ [min ⁻¹]	Rd	P _{t0}	T _{2M} [Nm]	P [kW]	T ₂ [Nm]	P ₁ [kW]	FS'	Input - IEC					
										B5			B14		
48.8	30	47	0.82	3.2	807	4.83	668	4	1.2	112 100	90	80	112 100	90	—
	40	35	0.80		825	3.78	655	3	1.3						
	60	23	0.76		864	2.76	689	2.2	1.3						
	80	18	0.74		957	2.37	887	2.2	1.1						
	100	14	0.72		884	1.80	884	1.8	1.0						
	120	12	0.66		916	1.70	809	1.5	1.1						
	160	9	0.62		970	1.42	749	1.1	1.3						
	200	7	0.60		896	1.10	896	1.1	1.0						
	260	5	0.55		743	0.75	743	0.75	1.0						
	320	4	0.52		722	0.64	624	0.55	1.2						
400	3	0.47	644	0.48	705	0.55	0.9								

110	n₁ = 900			HA					HF						
	i _n	n ₂ [min ⁻¹]	Rd	P _{t0}	T _{2M} [Nm]	P [kW]	T ₂ [Nm]	P ₁ [kW]	FS'	Input - IEC					
										B5			B14		
48.8	30	30	0.80	—	922	3.61	766	3	1.2	112 100	90	80	112 100	90	—
	40	23	0.78		937	2.82	732	2.2	1.3						
	60	15	0.74		970	2.06	849	1.8	1.1						
	80	11	0.72		970	1.59	912	1.5	1.1						
	100	9	0.69		970	1.32	811	1.1	1.2						
	120	8	0.63		970	1.21	884	1.1	1.1						
	160	6	0.60		970	0.96	758	0.75	1.3						
	200	5	0.57		970	0.81	902	0.75	1.1						
	260	4	0.52		846	0.60	779	0.55	1.1						
	320	3	0.49		794	0.48	616	0.37	1.3						
400	2	0.45	700	0.37	700	0.37	1.0								

110	n₁ = 500			HA					HF						
	i _n	n ₂ [min ⁻¹]	Rd	P _{t0}	T _{2M} [Nm]	P [kW]	T ₂ [Nm]	P ₁ [kW]	FS'	Input - IEC					
										B5			B14		
48.8	30	17	0.78	—	970	2.16	336	0.75	2.9	112 100	90	80	112 100	90	—
	40	13	0.76		970	1.67	437	0.75	2.2						
	60	8	0.72		970	1.18	616	0.75	1.6						
	80	6	0.69		970	0.92	792	0.75	1.2						
	100	5	0.67		970	0.75	970	0.75	1.0						
	120	4	0.60		970	0.71	754	0.55	1.3						
	160	3	0.56		970	0.57	933	0.55	1.1						
	200	2.5	0.53		970	0.48	754	0.37	1.3						
	260	2	0.49		955	0.39	900	0.37	1.1						
	320	1.5	0.46		889	0.32	700	0.25	1.3						
400	1	0.41	727	0.23	568	0.18	1.3								

* **ATTENZIONE:** la coppia massima utilizzabile [T_{2M}] deve essere calcolata utilizzando il fattore di servizio: T_{2M} = T₂ x FS'

* **WARNING:** Maximum allowable torque [T_{2M}] must be calculated using the following service factor : T_{2M} = T₂ x FS'

* **ACHTUNG:** das max. anwendbare Drehmoment [T_{2M}] muss mit folgendem Betriebsfaktor berechnet werden: T_{2M} = T₂ x FS'

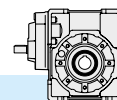

4.5 Dati tecnici

4.5 Technical data

4.5 Technische Daten

130	$n_1 = 2800$			HA					HF					
	i_n	n_2 [min ⁻¹]	Rd	P_{t0}	T_{2M} [Nm]	P [kW]	T_2 [Nm]	P_1 [kW]	FS'	Input - IEC				
					B5			B14						
 60	30	93	0.85	—	976	11.22	652	7.5	1.5	112 100	90	80	—	
	40	70	0.84		994	8.67	860	7.5						1.2
	60	47	0.80		1086	6.63	900	5.5						1.2
	80	35	0.78		1216	5.71	1171	5.5						1.0
	100	28	0.78		1170	4.40	1064	4.0						1.1
	120	23	0.72		1203	4.08	1179	4						1.0
	160	18	0.70		1306	3.42	1146	3						1.1
	200	14	0.67		1175	2.57	1005	2.2						1.2
	260	11	0.64		1008	1.78	851	1.5						1.2
	320	9	0.61		971	1.46	732	1.1						1.3
400	7	0.57	889	1.14	855	1.1	1.0							

130	$n_1 = 1400$			HA					HF					
	i_n	n_2 [min ⁻¹]	Rd	P_{t0}	T_{2M} [Nm]	P [kW]	T_2 [Nm]	P_1 [kW]	FS'	Input - IEC				
					B5			B14						
 60	30	47	0.83	4.9	1231	7.3	928	5.5	1.3	112 100	90	80	—	
	40	35	0.81		1238	5.6	1216	5.5						1.0
	60	23	0.77		1375	4.3	1279	4						1.1
	80	18	0.75		1472	3.7	1194	3						1.2
	100	14	0.74		1413	2.8	1111	2.2						1.3
	120	12	0.68		1407	2.6	1191	2.2						1.2
	160	9	0.65		1517	2.2	1517	2.2						1.0
	200	7	0.62		1353	1.6	1269	1.5						1.1
	260	5	0.58		1219	1.1	1219	1.1						1.0
	320	4	0.55		1182	0.9	1182	0.9						1.0
400	3	0.51	1136	0.7	893	0.55	1.3							

130	$n_1 = 900$			HA					HF					
	i_n	n_2 [min ⁻¹]	Rd	P_{t0}	T_{2M} [Nm]	P [kW]	T_2 [Nm]	P_1 [kW]	FS'	Input - IEC				
					B5			B14						
 60	30	30	0.81	—	1424	5.5	774	3	1.8	112 100	90	80	—	
	40	23	0.80		1429	4.2	1019	3						1.4
	60	15	0.75		1520	3.2	1433	3						1.1
	80	11	0.72		1694	2.8	1345	2.2						1.3
	100	9	0.72		1726	2.3	1681	2.2						1.0
	120	8	0.64		1632	2.0	1508	1.85						1.1
	160	6	0.61		1723	1.7	1553	1.5						1.1
	200	5	0.58		1542	1.3	1354	1.1						1.1
	260	4	0.54		1282	0.87	1102	0.75						1.2
	320	3	0.51		1298	0.75	1299	0.75						1.0
400	2	0.47	1126	0.56	1097	0.55	1.0							

130	$n_1 = 500$			HA					HF					
	i_n	n_2 [min ⁻¹]	Rd	P_{t0}	T_{2M} [Nm]	P [kW]	T_2 [Nm]	P_1 [kW]	FS'	Input - IEC				
					B5			B14						
 60	30	17	0.78	—	1659	3.7	335	0.75	4.9	112 100	90	80	—	
	40	13	0.76		1616	2.8	435	0.75						3.7
	60	8	0.72		1786	2.2	619	0.75						2.9
	80	6	0.70		1819	1.7	802	0.75						2.3
	100	5	0.69		1821	1.4	988	0.75						1.8
	120	4	0.61		1816	1.3	1049	0.75						1.7
	160	3	0.57		1796	1.0	1306	0.75						1.4
	200	2.5	0.54		1723	0.84	1547	0.75						1.1
	260	2	0.50		1485	0.60	1366	0.55						1.1
	320	1.5	0.47		1392	0.48	1063	0.37						1.3
400	1	0.44	1282	0.38	1244	0.37	1.0							

* **ATTENZIONE:** la coppia massima utilizzabile $[T_{2M}]$ deve essere calcolata utilizzando il fattore di servizio: $T_{2M} = T_2 \times FS'$

* **WARNING:** Maximum allowable torque $[T_{2M}]$ must be calculated using the following service factor: $T_{2M} = T_2 \times FS'$

* **ACHTUNG:** das max. anwendbare Drehmoment $[T_{2M}]$ muss mit folgendem Betriebsfaktor berechnet werden: $T_{2M} = T_2 \times FS'$

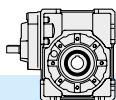

4.6 **Momenti d'inerzia** [Kg·cm²]
(riferiti all'albero veloce in entrata)

4.6 **Moments of inertia** [Kg·cm²]
(referred to input shaft)

4.6 **Trägheitsmoment** [Kg·cm²]
(bez. Antriebswelle)

	i_n	HA	HF	
			B5 - B14	
			IEC 56	IEC 63
H40	30	0.080	0.125	0.125
	40	0.079	0.123	0.124
	60	0.077	0.122	0.123
	80	0.076	0.120	0.121
	100	0.075	0.120	0.120
	120	0.077	0.121	0.122
	160	0.075	0.120	0.120
	200	0.075	0.120	0.120
	260	0.074	0.119	0.119
	320	0.074	0.119	0.119
	400	0.074	0.119	0.119

	i_n	HA	HF		
			B5	B5 - B14	
			IEC 56	IEC 63	IEC 71
H50	30	0.161	0.208	0.366	0.383
	40	0.156	0.203	0.361	0.377
	60	0.152	0.199	0.357	0.374
	80	0.148	0.194	0.352	0.369
	100	0.147	0.194	0.352	0.368
	120	0.150	0.197	0.355	0.372
	160	0.146	0.193	0.351	0.368
	200	0.141	0.188	0.346	0.363
	260	0.138	0.185	0.343	0.360
	320	0.138	0.185	0.343	0.360
	400	0.138	0.185	0.343	0.360

	i_n	HA	HF		
			B5	B5 - B14	
			IEC 63	IEC 71	IEC 80
H63	30	0.405	0.639	0.656	1.219
	40	0.392	0.626	0.643	1.206
	60	0.383	0.617	0.634	1.197
	80	0.364	0.598	0.615	1.178
	100	0.362	0.596	0.613	1.176
	120	0.377	0.612	0.628	1.191
	160	0.361	0.595	0.612	1.175
	200	0.360	0.595	0.611	1.175
	260	0.354	0.588	0.605	1.168
	320	0.354	0.588	0.605	1.168
	400	0.354	0.588	0.605	1.168

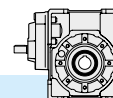

	i_n	HA	HF		
			B5	B5 - B14	
			IEC 71	IEC 80	IEC 90
H75	30	0.865	1.643	1.778	2.855
	40	0.835	1.613	1.748	2.825
	60	0.813	1.592	1.726	2.804
	80	0.777	1.556	1.690	2.768
	100	0.773	1.551	1.686	2.764
	120	0.801	1.579	1.714	2.791
	160	0.770	1.548	1.683	2.760
	200	0.769	1.547	1.682	2.759
	260	0.751	1.530	1.664	2.742
	320	0.751	1.530	1.664	2.742
	400	0.751	1.529	1.664	2.742







4.6 **Momenti d'inerzia** [Kg·cm²]
(riferiti all'albero veloce in entrata)

4.6 **Moments of inertia** [Kg·cm²]
(referred to input shaft)

4.6 **Trägheitsmoment** [Kg·cm²]
(bez. Antriebswelle)

	i_n	HA 	HF 		
			B5		
			IEC 71	IEC 80	IEC 90
H90	30	1.064	1.843	1.977	3.055
	40	1.000	1.779	1.913	2.991
	60	0.955	1.733	1.868	2.945
	80	0.845	1.623	1.758	2.835
	100	0.836	1.615	1.749	2.827
	120	0.927	1.706	1.840	2.918
	160	0.829	1.608	1.742	2.820
	200	0.827	1.606	1.740	2.818
	260	0.784	1.562	1.696	2.774
	320	0.783	1.562	1.696	2.774
	400	0.783	1.561	1.695	2.773

	i_n	HA 	HF 		
			B5		
			IEC 80	IEC 90	IEC 110-112
H110	30	2.558	4.726	4.654	6.424
	40	2.379	4.547	4.475	6.246
	60	2.251	4.420	4.347	6.118
	80	1.958	4.127	4.054	5.825
	100	1.933	4.102	4.029	5.800
	120	2.175	4.343	4.271	6.041
	160	1.915	4.084	4.011	5.782
	200	1.909	4.077	4.005	5.776
	260	1.779	3.948	3.875	5.646
	320	1.778	3.946	3.874	5.645
	400	1.777	3.945	3.873	5.644

	i_n	HA 	HF 		
			B5		
			IEC 80	IEC 90	IEC 110-112
H130	30	5.64	7.90	10.22	11.83
	40	5.15	7.42	9.73	11.35
	60	4.81	7.07	9.39	11.00
	80	4.15	6.41	8.72	10.34
	100	4.07	6.34	8.65	10.27
	120	4.60	6.86	9.18	10.79
	160	4.03	6.29	8.61	10.22
	200	4.01	6.27	8.59	10.20
	260	3.75	6.01	8.32	9.94
	320	3.74	6.00	8.32	9.93
	400	3.74	6.00	8.32	9.93

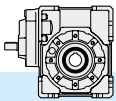

4.7 Dimensioni

4.7 Dimensions

4.7 Abmessungen

HA

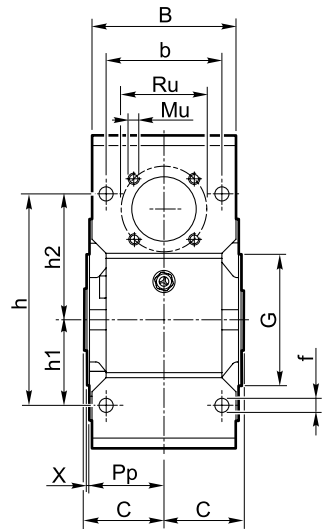
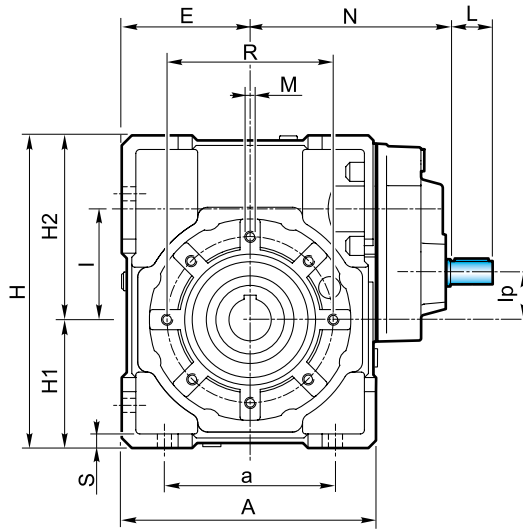

HF

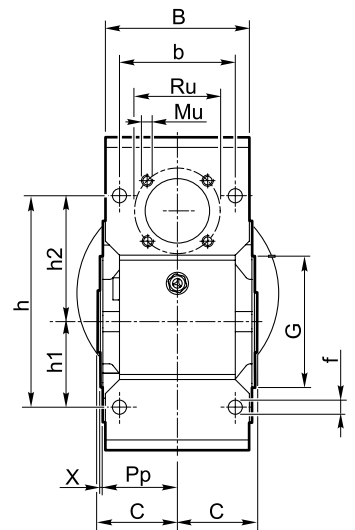
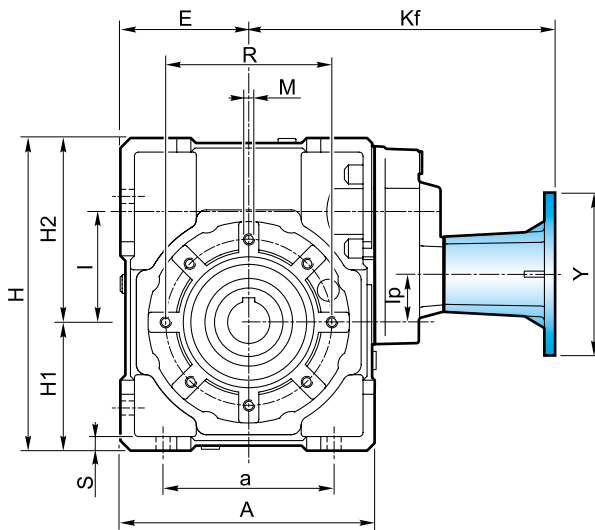

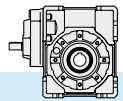

Flangia pendolare / Shaft-mounted flange / Aufsteckflansch

40 - 50

63 - 75 - 90 - 110 - 130

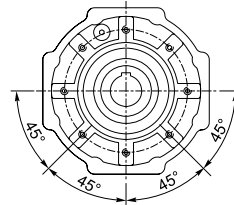
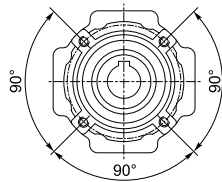

4 Fori / Holes / Bohrungen

8 Fori / Holes / Bohrungen

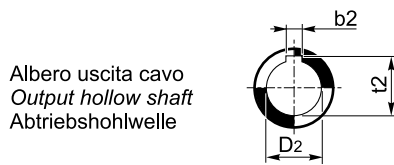

Albero uscita cavo
Output hollow shaft
Abtriebshohlwelle

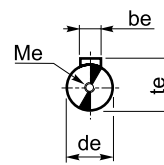

Albero entrata
Input shaft
Antriebswelle

H	A	a	B	b	b _e	b ₂	C	d _e j6	D ₂ H8	E	f	G h8	H	H ₁	H ₂	h	h ₁	h ₂	
40	105	70	71	60	3	6	6	9	18	19	50	6.5	60	125	50	75	90	35	55
50	125	80	85	70	4	8	8	11	25	24	60	8.5	70	150	60	90	104	40	64
63	147	100	103	85	5	8	—	14	25	—	72	9	80	182	72	110	130	50	80
75	176	120	112	90	6	8	8	19	28	30	86	11	95	219.5	86	133.5	153	60	93
90	203	140	130	100	6	10	—	19	35	—	103	13	110	248.5	103	145.5	172	70	102
110	252.5	170	143	115	8	12	—	24	42	—	127.5	14	130	310.5	127.5	183	210	85	125
130	292.5	200	155	120	8	14	14	24	45	48	147.5	15	180	355	147.5	207.5	240	100	140

H	I	I _p	L	M	M _e	M _u	N	P _p	R	R _u	S	t _e	t ₂	X	
40	40	5	15	M6X10	M4X12	M5X10	91.5	36.5	75	42.4	6	10.2	20.8	21.8	1.5
50	50	10	20	M8x10	M4x12	M6x10	104.5	43.5	85	53.7	7	12.5	28.3	27.3	1.5
63	63	16.5	25	M8x14	M4x10	M6x12	121	53	95	60.8	8	16	28.3	—	2
75	75	22	30	M8x14	M6x16	M8x12	147.75	57	115	70.7	10	21.5	31.3	33.3	2
90	90	37	30	M10x18	M6x16	M8x14	157.75	67	130	70.7	12	21.5	38.3	—	2
110	110	47	40	M10x18	M8x22	M10x18	196.5	74	165	85.0	14	27	45.3	—	2.5
130	130	55	50	M12x20	M8x14	M10x16	240	81	215	104	15	27	48.8	51.8	3

Dimensioni attacco flangia entrata

Dimensions of the input mounting flange

Abmessungen des Eintriebsflansches

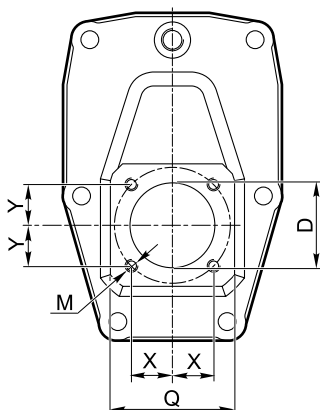

H	D	M	Q	X	Y
40	26	M5x9	40	12.5	12.5
50	32	M5x9	45	15	15
63	40	M6x12	53	19	19
75	47	M6x12	62	21.5	21.5
90	47	M6x12	62	21.5	21.5
110	52	M8x15	75	25	25
130	62	M10x17	92	30	30

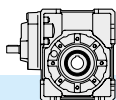

4.7 Dimensioni

4.7 Dimensions

4.7 Abmessungen

Flangia uscita / Output flange / Abtriebsflansch

Vista da A / View from A / Ansicht von A

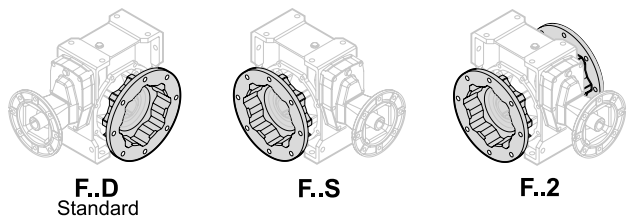
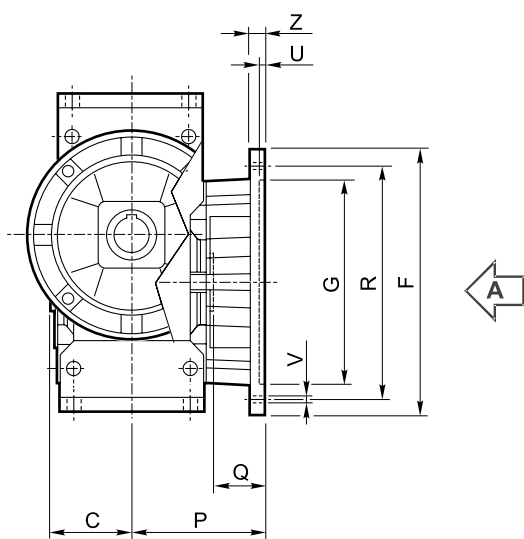

40	50
F1	F1
F2	—
—	—

40	50
—	—
—	F2
F3	—

40 - 50

63	75
F1	F1
F2	—
—	—

63	75
—	—
—	F2
F3	—

63 - 75

90	110
—	F1
—	—
—	—

90	110
F1	—
F2	F2
F3	—

90 - 110

130
F1
F2
—

130

Tipo Type Typ	C	F		G H8	P	Q	R	U	V			Z
											Ø	
40	39		85	60	67	28	75-90	4	n° 4		9	8
			85	60	97	58	75-90	4	n° 4		9	8
		140		95	80	41	115	5		n° 7	9	10
50	46		94	70	90	44	85-100	5	n° 4		11	10
		160		110	89	43	130	5		n° 7	11	11
63	56		142	115	82	26	150	5	n° 4		11	11
			142	115	112	56	150	5	n° 4		11	11
		160		110	80.5	24.5	130	5	n° 4		11	12
75	60		160	130	111	51	165	5	n° 4		13	12
		160		110	90	30	130	6	n° 4		11	13
90	70		200	152	111	41	175	5	n° 4		13	12
			200	152	151	81	175	5	n° 4		13	13
			200	130	110	40	165	6	n° 4		11	11
110	77.5		260	170	131	53.5	230	6		n° 8	13	15
			250	180	150	72.5	215	5	n° 4		15	16
130	85		320	180	140	55	255	7		n° 8 *	16	16
			300	230			265					

* Foratura ruotata di 22.5°

* Drilling turned of 22.5°

* Durchbohrung 22.5° versetzt

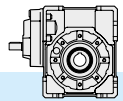

4.7 Dimensioni

4.7 Dimensions

4.7 Abmessungen

Flangia entrata / Input flange / Antriebsflansch

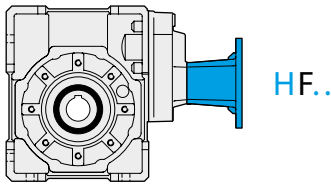

HF..

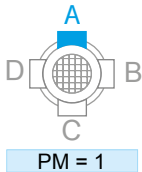

PM = 1

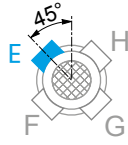

PM = 2

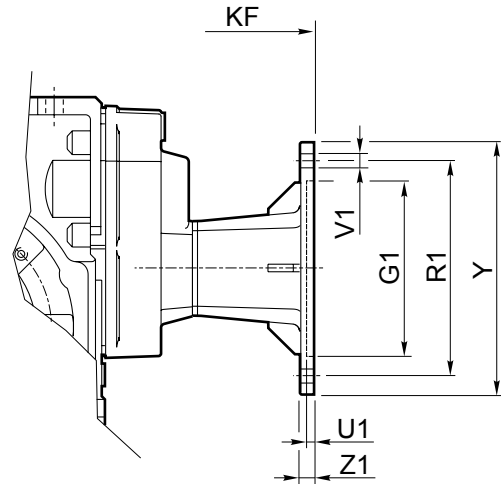

HF	IEC	PM		G ₁	K _F	R ₁	U ₁	Ø	V ₁			Y	Z ₁
		1	2										
40	56 B5	•	•	80	129.5	100	3.5	7		8		120	8
	56 B14		•	50	129.5	65	3.5	6			4	80	8
	63 B5	•	•	95	132.5	115	4	9		8		140	10
	63 B14	•	•	60	132.5	75	3.5	6			8	90	8
50	56 B5	•	•	80	148.5	100	3.5	7		8		120	8
	63 B5	•	•	95	151.5	115	4	9		8		140	10
	63 B14	•	•	60	151.5	75	3.5	6			8	90	8
	71 B5	•	•	110	158.5	130	4.5	9		8		160	10
	71 B14	•	•	70	158.5	85	4	7			8	105	10
63	63 B5	•	•	95	173	115	4	9		8		140	10
	71 B5	•	•	110	180	130	4.5	9		8		160	10
	71 B14		•	70	180	85	3.5	7			4	105	10
	80 B5	•	•	130	190	165	4.5	11		8		200	10
	80 B14	•	•	80	190	100	4	7			8	120	10
75	71 B5	•	•	110	221.5	130	4.5	9		8		160	10
	80/90 B5	•	•	130	232	165	4.5	11		8		200	10
	80 B14	•	•	80	222	100	4	7			8	120	10
	90 B14	•	•	95	232	115	4	9		8		140	10
90	71 B5	•	•	110	221.5	130	4.5	9		8		160	10
	80/90 B5	••	•	130	242	165	4.5	11		8		200	10
	80 B14	•	•	80	232	100	4	7			8	120	10
	90 B14	•	•	95	242	115	4	9		8		140	10
110	80/90 B5	•	•	130	294.5	165	4.5	11		8		200	10
	90 B14		•	95	294.5	115	4	9			4	140	10
	100/112 B5	•	•	180	304.5	215	5	14		8		250	14
	100/112 B14	•	•	110	304.5	130	4.5	9			8	160	10
130	80/90 B5	•	•	130	345.5	165	4.5	11	4			200	12
	100/112 B5	•	•	180	355.5	215	5	14	4			250	14

N.B.: Il montaggio STD di P_M=2 solo quando non è possibile il montaggio STD di P_M=1.

N.B.: STD mounting of P_M=2 only if STD mounting of P_M=1 is not possible.

ANMERKUNG: STD Montage von P_M=2 nur wenn STD Montage von P_M=1 unmöglich ist.

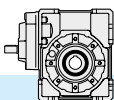

4.8 Entrata supplementare (vite bisporgente)

4.8 Additional input (double extended shaft)

4.8 Zusatzantrieb (beidseitige Welle)

S.e.A.

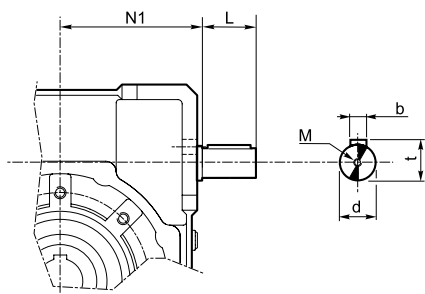

NOTA: L'entrata supplementare nella serie H si trova nella posizione intermedia del cinematismo. Quindi, se utilizzata come comando, avrà la sola riduzione della coppia vite/corona. Se invece viene utilizzata come asse condotto, la sua velocità sarà quella in entrata ridotta dal rapporto 4:1 della precoppia.

NOTE: the second shaft of the H series gearboxes is placed in the intermediate position of the kinematic motion which if used as a drive will have only the reduction of the worm/wheel set. For the utilization as a driven shaft its speed will correspond to the input speed reduced by the ratio 4:1 of the pre-stage.

BEMERKUNG: das zweite Wellenende der Getriebe der Serie H befindet sich in der Mitte des Getriebes. Falls das zweite Wellenende als zusätzliche Antriebswelle genutzt werden, muss aufgrund der Vorstufe mit einer um 4:1 reduzierte Drehzahl eingetrieben werden.

H	d j6	L	M	N1	b	t
40	11	20	M4x12	52.5	4	12.5
50	14	25	M5x13	62.5	5	16
63	19	30	M8x20	74.5	6	21.5
75	24	40	M8x20	91	8	27
90	24	40	M8x20	108	8	27
110	28	50	M8x20	132.5	8	31
130	38	70	M10x25	152	10	41

4.9 Limitatore di coppia cavo passante

4.9 Torque limiter with through hollow shaft

4.9 Drehmomentbegrenzer mit durchgehender Hohlwelle

Il limitatore di coppia viene consigliato in tutte quelle applicazioni che richiedono una limitazione sulla coppia trasmissibile per proteggere l'impianto e/o preservare il riduttore evitando sovraccarichi o urti indesiderati quanto inaspettati.

È un dispositivo con albero dotato di cavo passante, con funzionamento a frizione, ed è integrato al riduttore, presentando un ingombro limitato.

Concepito per lavorare a bagno d'olio, il dispositivo risulta affidabile nel tempo ed è esente da usura se non viene mantenuto in condizioni prolungate di slittamento (condizione che si verifica quando la coppia presenta valori superiori a quelli di taratura).

La taratura è facilmente regolabile dall'esterno attraverso il serraggio di una ghiera autobloccante che porta a compressione le 4 molle a tazza disposte tra loro in serie.

Il dispositivo non consente:

- l'impiego di cuscinetti a rulli conici in uscita
- funzionamento prolungato in condizioni di slittamento.

Nella tabella seguente vengono riportati i valori delle coppie di slittamento M_{2S} in funzione del n° di giri della ghiera.

I valori di taratura presentano una tolleranza del $\pm 10\%$ e si riferiscono ad una condizione statica.

In condizioni dinamiche è da notare che la coppia di slittamento assume valori diversi a seconda del tipo e/o modalità in cui si verifica il sovraccarico: con valori maggiori in caso di carico uniformemente crescente rispetto a valori più contenuti in seguito al verificarsi di picchi improvvisi di carico.

NOTA: quando si supera il valore di taratura si ha slittamento. Il coefficiente di attrito tra le superfici di contatto da statico diventa dinamico e la coppia trasmessa cala del 30% circa.

È quindi opportuno prevedere uno stop per poter ripartire al valore di taratura iniziale.

The use of a torque limiter is advisable in case of applications requiring the limitation of the torque in order to safeguard the plant and/or the gearbox against unexpected and undesired overloads or shocks.

The torque limiter is equipped with a through hollow shaft and friction clutch. It is integrated in the gearbox, space requirement is therefore limited.

Designed to work in oil bath, it is reliable over time and is not subject to wear unless prolonged slipping occurs (it happens when the torque values are higher than the calibration values).

Calibration can be easily adjusted from the outside by tightening the self-locking ring nut, which causes the compression of 4 Belleville washers arranged in series.

The use of the torque limiter does not go together with:

- the use of tapered roller bearings at output
- Prolonged operation under slipping conditions.

The following table shows the values of M_{2S} slipping torques depending on the number of revolutions of the ring nut.

Calibration values feature a $\pm 10\%$ tolerance and refer to static conditions.

Under dynamic conditions, the values of the slipping torque differ depending to the type of overload: the values are higher if the load increase is uniform, the values are lower if sudden load peaks occur.

NOTE: Slipping occurs when the setting values are exceeded.

The friction coefficient between the contact surfaces from static becomes dynamic and the transmitted torque is approx. 30% lower.

It is advisable to have a stop first in order to have a restart based on the initial setting value.

Die Anwendung eines Drehmomentbegrenzers wird empfohlen, um die Anlage und das Getriebe gegen unerwünschte und unerwartete Überbelastungen und Stoßen zu schützen. Der Begrenzer verfügt über eine durchgehende Hohlwelle und eine Kupplung. Er ist in dem Getriebe integriert, d.h. der Raumbedarf ist klein.

Der Drehmomentbegrenzer wurde für Betrieb in Ölbad entworfen. Er ist zuverlässig über Zeit und verschleißfest (ausser wenn Rutschen für lange Zeit besteht: das passiert, wenn das Drehmoment höher als der Eichwert ist).

Die Eichung darf mühelos von aussen durch das Anziehen einer selbstsperrenden Mutter ausgeführt werden. Das Anziehen verursacht die Zusammendrückung der 4 wechelsinnige schichteten Tellerfeder.

Der Drehmomentbegrenzer sieht das folgende nicht vor:

- die Verwendung von Kegelrollenlager am Abtrieb
- Längerer Rutschbetrieb.

Die nachstehende Tabelle zeigt die Werte der Rutschmomente M_{2S} abhängig von der Zahl der Umdrehungen der Mutter.

Die Eichwerte weisen $\pm 10\%$ Toleranz auf und beziehen sich auf statische Bedingungen.

Unter dynamischen Bedingungen hat das Rutschmoment verschiedene Werte je nach Art der Überbelastung. Die Werte sind höher, wenn die Belastung gleichmäßig zunimmt; sie sind niedriger im Falle von plötzlichen Belastungsspitzen.

BEMERKUNG: Rutschen tritt auf, wenn die eingestellten Werte überschritten werden. Der Reibungsfaktor zwischen den Berührungsf lächen wird dynamisch anstatt statisch und das übertragene Drehmoment sinkt um ca. 30%.

Es ist daher ratsam, vor dem erneuten Anfahren anzuhalten, um die ursprünglichen Drehmomentwerte zu erreichen.

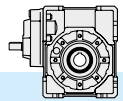

E' importante notare che la coppia di slittamento non resta sempre la medesima durante tutta la vita del limitatore.

Tende infatti a diminuire in rapporto al numero e alla durata degli slittamenti che, rodando le superfici di contatto, ne aumentano il rendimento.

È quindi opportuno verificare periodicamente, soprattutto durante la fase di rodaggio, la taratura del dispositivo.

Là dove sia richiesto un errore più contenuto nella taratura, è necessario testare la coppia trasmissibile sull'impianto.

Il dispositivo viene consegnato tarato alla coppia riportata a catalogo T_{2M} salvo diversa indicazione espressa in fase di ordinazione.

It is important to note that the slipping torque is not the same for the entire life of the torque limiter. It usually decreases in connection with the number and the duration of slippings, this is due to the surfaces of the torque limiter becoming more engaged, therefore increasing the efficiency.

For this reason it is advisable to check the calibration of the device at regular intervals, specially during the running-in period.

Should a smaller calibration error be required, it is necessary to test the transmissible torque on the plant. The torque limiter is supplied already calibrated at the torque value reported in the catalogue T_{2M} , unless otherwise specified on the order.

Es ist wichtig zu beachten, dass das Rutschmoment der Rutschkupplung über die gesamte Lebensdauer nicht konstant bleibt, sondern üblicherweise in Verbindung mit längeren Rutschzyklen aufgrund der eingelaufenen Berührungsflächen abnimmt.

Deswegen ist es ratsam, die Einstellung der Vorrichtung besonders während der Einlaufzeit in regelmäßigen Zeitabständen zu prüfen.

Wenn der Drehmomentbegrenzer geliefert wird, ist dieser schon auf dem im Katalog unter T_{2M} angegebenen Wert eingestellt, außer wenn es in der Bestellung anders angegeben wird.

H	N°. giri della ghiera di regolazione / N°. revolutions of ring nut / Nr. Umdrehungen der Mutter															
	1 1/4	1 1/2	1 3/4	2	2 1/4	2 1/2	2 3/4	3	3 1/4	3 1/2	3 3/4	4	4 1/4	4 1/2	4 3/4	5
	M_{2S} [Nm]															
40	35	40	45	50	55	60	65									
50	60	70	80	90	100	110	115	120								
63				115	125	130	140	155	165	175	180	190	200	220		
75		220	245	275	310	350										
90	250	290	330	365	410	435	465	500	530	560	580					
110	500	560	670	730	810	910	940	970								
130																

Disposizione delle molle
Washers' arrangement
Lage der Feder

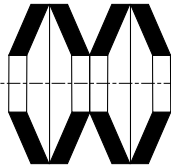

IN SERIE (min. coppia, max. sensibilità)
SERIES (min. torque, max. sensitivity)
SERIE (min. Moment, max. Empfindlichkeit)

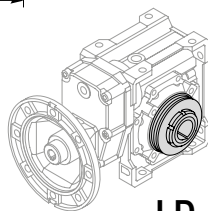
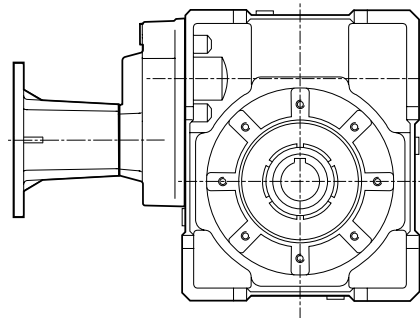
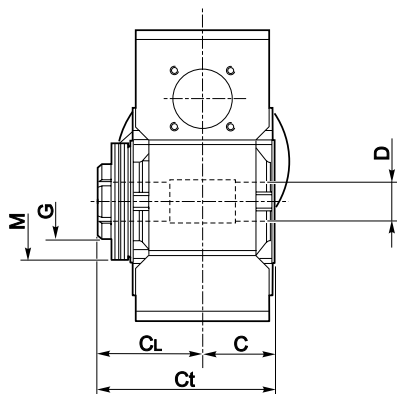

LD

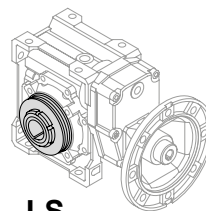

LS

H	C	C _L	C _t	D _{H8}	M	G
40	39	65	104	18 (19)	56x30.5x1.5	M30x1.5
50	46	76	122	25 (24)	63x40.5x1.8	M40x1.5
63	56	91	147	25	71x40.5x2	M40x1.5
75	60	100	160	28 (30)	90x50.5x3.5	M50x1.5
90	70	109	179	35 (32)	100x51x2.7	M50x1.5
110	77.5	127.5	205	42	125x61x4	M60x2.0
130						

Nella versione con limitatore non è prevista la fornitura degli alberi lenti.

The version with torque limiter is supplied without output shafts.

Die Version mit Drehmomentbegrenzer wird ohne Abtriebswellen geliefert.

() A richiesta / On request / Auf Anfrage

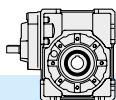

4.10 Accessori

4.10 Accessories

4.10 Accessories

Albero lento

Output shaft

Abtriebswelle

Albero lento semplice
Single output shaft
Standard Abtriebswelle

Albero lento doppio
Double output shaft
Doppelte Abtriebswelle

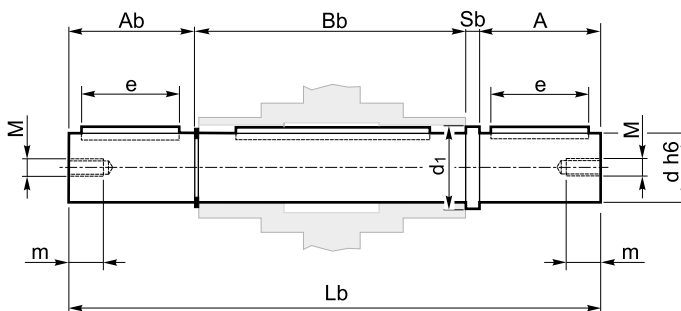
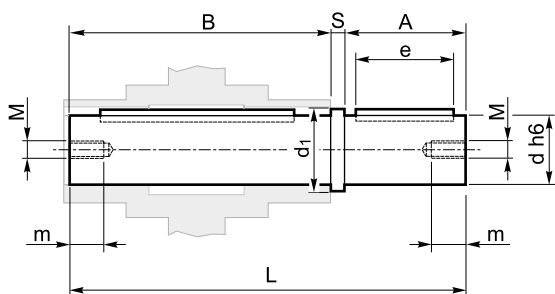

X	A	B	d _{h6}		d ₁	e	L	M	m	S
40	40	77	18	19	23.5	30	120	M6	16	3
50	50	90	25	24	31.5	40	143.5	M8	22	3.5
63	50	111	25	30	31.5	40	165	M8	22	4
75	60	119	28	30	34.5	50	183	M8	22	4
90	80	139	35	41.5	60	224	M10	28	5	
110	80	154.5	42	49.5	60	242.5	M10	28	8	
130	80	168	45	54.5	70	253	M16	36	5	

A	A _b	B _b	d _{h6}	d ₁	e	L _b	S _b
40	39	79	18	23.5	30	161	3
50	49	93	25	31.5	40	195.5	3.5
50	49	113	25	31.5	40	216	4
60	59	121	28	34.5	50	244	4
80	78.5	141.5	35	41.5	60	305	5
80	77.5	157	42	49.5	60	322.5	8
80	78	172	45	54.5	70	335	5

Braccio di reazione

Torque arm

Drehmomentstütze

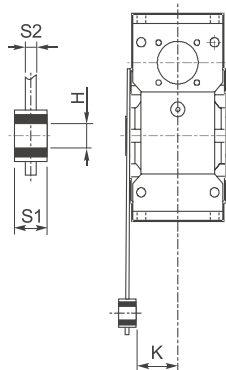
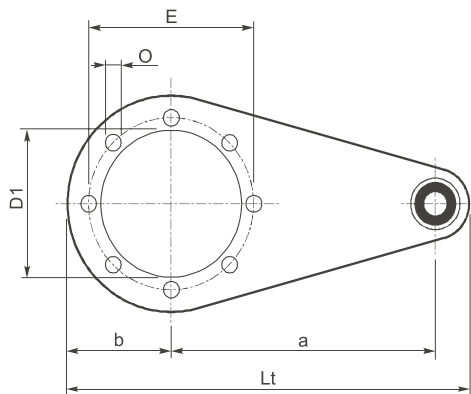

H	a	b	D ₁	E	H	K	L _t	O	S1	S2
40	100	45	60	75	10	31.5	167	7	14	4
50	100	50	70	85	10	39	172	9	14	5
63	150	55	80	95	10	49	227	9	14	6
75	200	70	95	115	20	47.5	302	9	25	6
90	200	80	110	130	20	57.5	312	11	25	6
110	250	100	130	165	25	62	390	11	30	6
130	250	125	180	215	25	69	415	13	30	6

Kit di protezione:

Protection Kit:

Schutzvorrichtung

Albero cavo / Hollow shaft / Hohlwelle

Limitatore di coppia / Torque limiter / Drehmomentbegrenzer

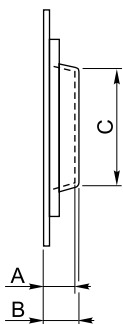

	A	B	C
40	14	15.5	44
50	15	16.5	54
63	17	19	60
75	18	20	70
90	21.5	24	80
110	22	25	96
130	22	25	130

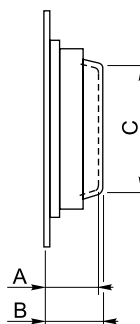

	A	B	C
40	40	41.5	44
50	47	48.5	53
63	52	54	55
75	58	60	68
90	60.5	63	70
110	72	75	85
130			

Opzioni disponibili:

Available options:

Auf Anfrage ist folgendes Zubehör erhältlich:

Cuscinetti a rulli conici corona

Tapered roller bearing on worm wheel

Kegelrollenlager auf Schneckenrad

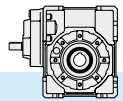

HA - HF

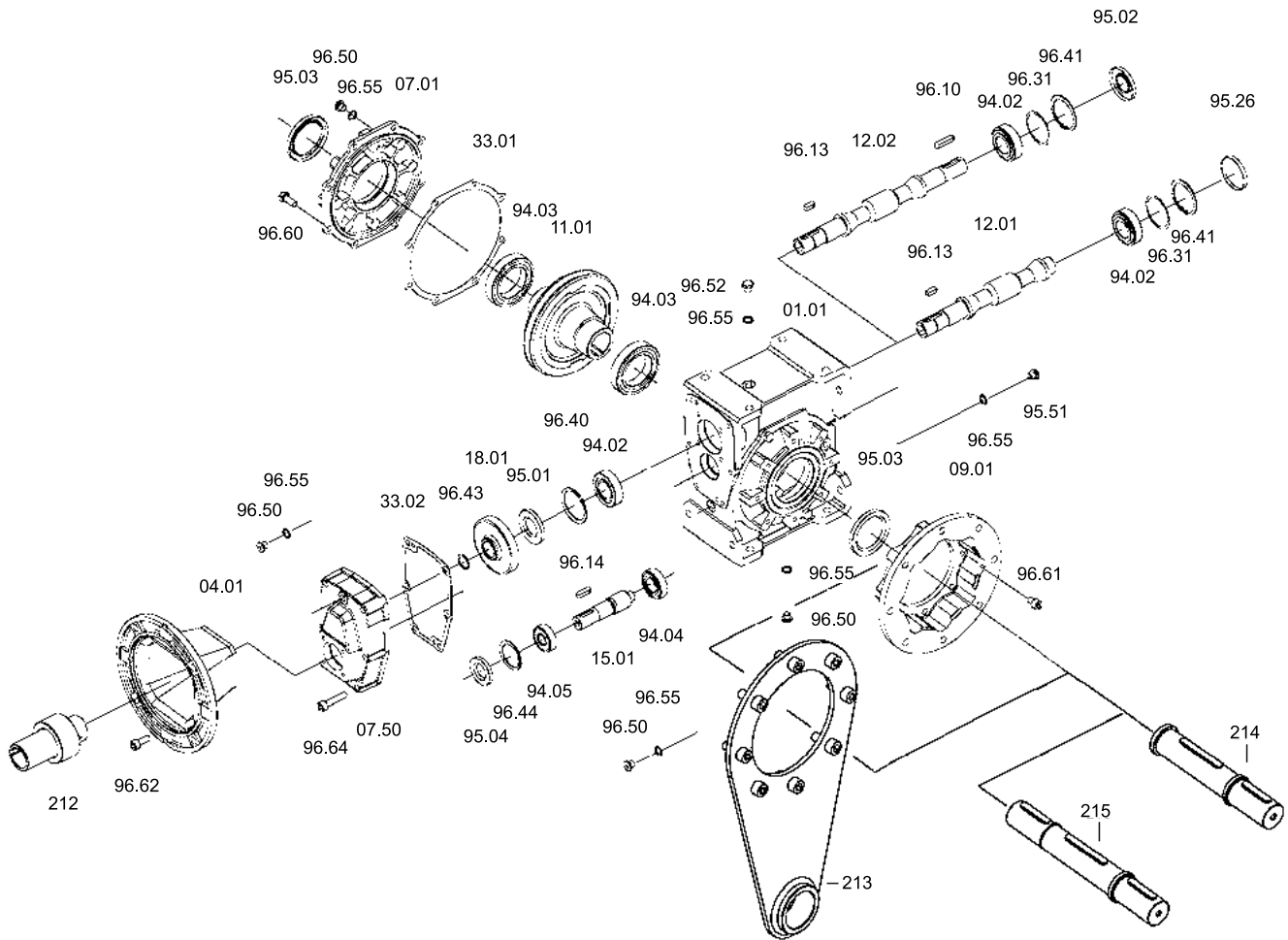

H	Cuscinetti / Bearings / Lager					Anelli di tenuta / Oilseals Öldichtungen				Cappello / Closed oil seal Geschlossene Öldichtung
	94.02	94.03		94.04	94.05	95.01	95.02	95.03	95.04	95.26
40	6201 12x32x10	6006 30x55x13	*32006 30x55x17	6000 10x26x8	6000 10x26x8	12/32/7	12/32/7	30/47/7	10/26/7	ø 32x7
50	6203 17x40x12	6008 40x68x15	*32008 40x68x19	6200 10x30x9	6201 12x32x10	17/40/7	17/40/7	40/62/8	12/32/7	ø 40x7
63	30204 20x47x15.25	6008 40x68x15	*32008 40x68x19	6201 12x32x10	6203 17x40x12	20/47/7	20/47/7	40/62/8	17/40/7	ø 47x7
75	30205 25x52x16.25	6010 50x80x16	*32010 50x80x20	6202 15x35x11	6204 20x47x14	25/52/7	25/52/7	50/72/8	20/47/7	ø 52x7
90	32205 25x52x19.25	6010 50x80x16	*32010 50x80x20	6202 15x35x11	6204 20x47x14	25/52/7	25/52/7	50/72/8	20/47/7	ø 52x7
110	32206B 30x62x21.25	6012 60x95x18	*32012 60x95x23	6303 17x47x14	6205 25x52x15	30/62/7	30/62/7	60/85/8	25/52/7	ø 62x7
130	33208 40x80x32	6015 75x115x20	*32015 75x115x25	6304 20x52x15	6305 25x62x17	40/80/10	40/80/10	75/100/10	25/62/8	ø 80x10

* Cuscinetti a rulli conici a richiesta - Tapered roller bearings on request - Auf Wunsch Kegelrollenlager

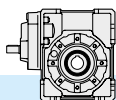

5.0	RIDUTTORI A VITE SENZA FINE COMBINATI	COMBINED WORM GEARBOXES	KOMBINIERTE- SCHNECKENGETRIEBE	
5.1	Caratteristiche	<i>Characteristics</i>	Merkmale	86
5.2	Designazione	<i>Designation</i>	Bezeichnung	86
5.3	Lubrificazione e posizioni di montaggio	<i>Lubrication and mounting position</i>	Schmierung und Einbaulage	90
5.4	Posizione morsettiera	<i>Terminal board position</i>	Lage der Klemmenkaste	92
5.5	Dati tecnici	<i>Technical data</i>	Technische Daten	93
5.6	Dimensioni	<i>Dimensions</i>	Abmessungen	98
5.7	Limitatore di coppia cavo passante	<i>Torque limiter with through hollow shaft</i>	Drehmomentbegrenzer mit durchgehender Hohlwelle	105
5.8	Esecuzione con vite bisporgente	<i>Double extended worm shaft design</i>	Versionen mit doppelseitig herausragender Schneckenwelle	106
5.9	Accessori	<i>Accessories</i>	Zubehör	107
5.10	Lista parti di ricambio	<i>Spare parts list</i>	Ersatzteilliste	108

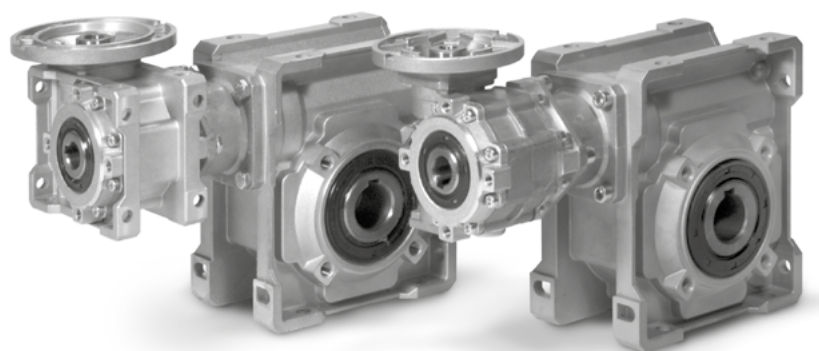

XX

KX

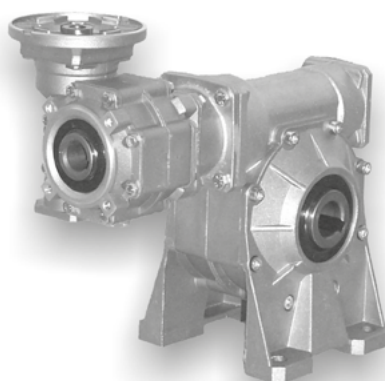

KK

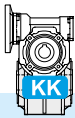

5.1 Caratteristiche

La combinazione di due riduttori a vite senza fine comporta rendimenti molto bassi, ma l'elevata riduzione di velocità ottenuta in uno spazio ridottissimo rende comunque interessante, e a volte insostituibile, questa soluzione. I riduttori a vite senza fine combinati sono disponibili nelle serie KX, XX e KK.

Le serie KX e KK sono disponibili esclusivamente nella versione p.a.m.

La serie XX è invece disponibile nella versione alberata XXA e nelle due versioni con predisposizione attacco motore in forma compatta XXC o con campana e giunto XXF.

Sono forniti con albero cavo di serie ed esiste un'ampia gamma di accessori: seconda entrata, cuscinetti conici sulla corona, flangia uscita, albero lento con 1 o 2 sporgenze, limitatore di coppia con cavo passante, braccio di reazione.

5.1 Characteristics

The combination of two worm gearboxes provides very low efficiency, however the fact that substantial reduction in speed can be obtained in an extremely reduced space makes this solution very interesting and sometimes irreplaceable. Combined worm gearboxes are available in series: KX, XX and KK.

The KX and KK series are available for IEC version only.

The XX series is available in the XXA version with shaft and in two versions with motor coupling: XXC (compact) and XXF (with bell and joint).

The hollow shaft is supplied as standard. A broad range of accessories is available: second input, tapered roller bearings on the worm wheel, output flange, single or double extended output shaft, torque limiter with through hollow shaft, torque arm.

5.1 Merkmale

Die Kombination zweier Schneckengetriebe bringt sehr niedrigen Wirkungsgrad mit sich, es handelt sich jedoch um eine interessante und manchmal unersetzbare Lösung, weil hohe Drehzahlverringern in einem beträchtlich reduzierten Raum erhalten werden kann. Kombinierte Schneckengetriebe sind in folgende Serien erhältlich: KX, XX und KK. Die Serien KX und KK sind nur mit IEC-Motoranbau verfügbar.

Die Serie XX ist mit Welle (XXA Version), oder mit Kupplung für Motoranschluss (XXC kompakt und XXF mit Glocke und Verbindsstück) lieferbar.

Die Hohlwelle gehört zur serienmäßigen Ausstattung. Eine breite Auswahl an Zubehör ist erhältlich: zweiter Antrieb, Kegelrollenlager auf Schneckenrad, Abtriebsflansch, Standard oder doppelseitig herausragende Abtriebswelle, Drehmomentbegrenzer mit durchgehender Hohlwelle, Drehmomentstütze.

5.2 Designazione

5.2 Designation

5.2 Bezeichnung

Riduttore entrata Gearbox at input Getriebe am Antrieb	Macchina uscita Gearbox at output Getriebe am Abtrieb	Tipo entrata Input type Antriebsart	Grandezza Size Größe	Rapporto rid. Ratio Untersetzung	Predispos.att. mot. Motor coupling Motoranschluss	Versione Version Version	Forma costruttiva Execution Bauform	Posizione di mont. Mounting position Einbaulage	Limitatore di coppia. Torque limiter Drehmomentbegrenzer	Seconda entrata Additional input Zusatzantrieb	Albero uscita Output shaft Abtriebswelle	Braccio di reazione Torque arm Drehmomentstütze
K	K	C	50/110 1200	150 200 300 450 600 900 1200 1500 1950 2500 3250 4000 5000 10000	P.A.M.	F1	a	B3	LD	SeA1	H	BR
Riduttore a vite senza fine combinato Combined worm gearbox Doppelschneckengetriebe							ab cd ef gh ik im no pq	B3 B6 B7 B8 V5 V6	 LD LS	 SeA1 SeA2	 H SD SS DD	 BR

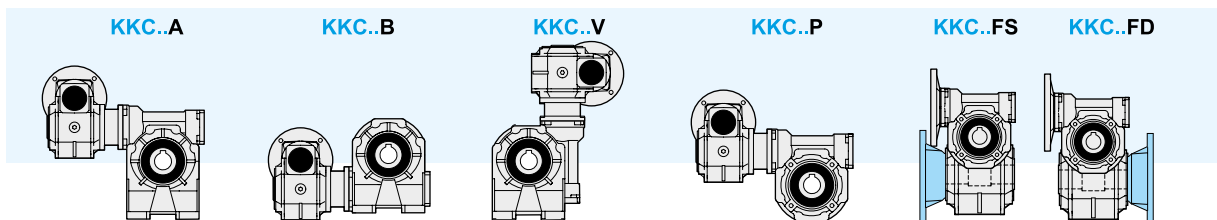

Forma costruttiva / version / Bauform

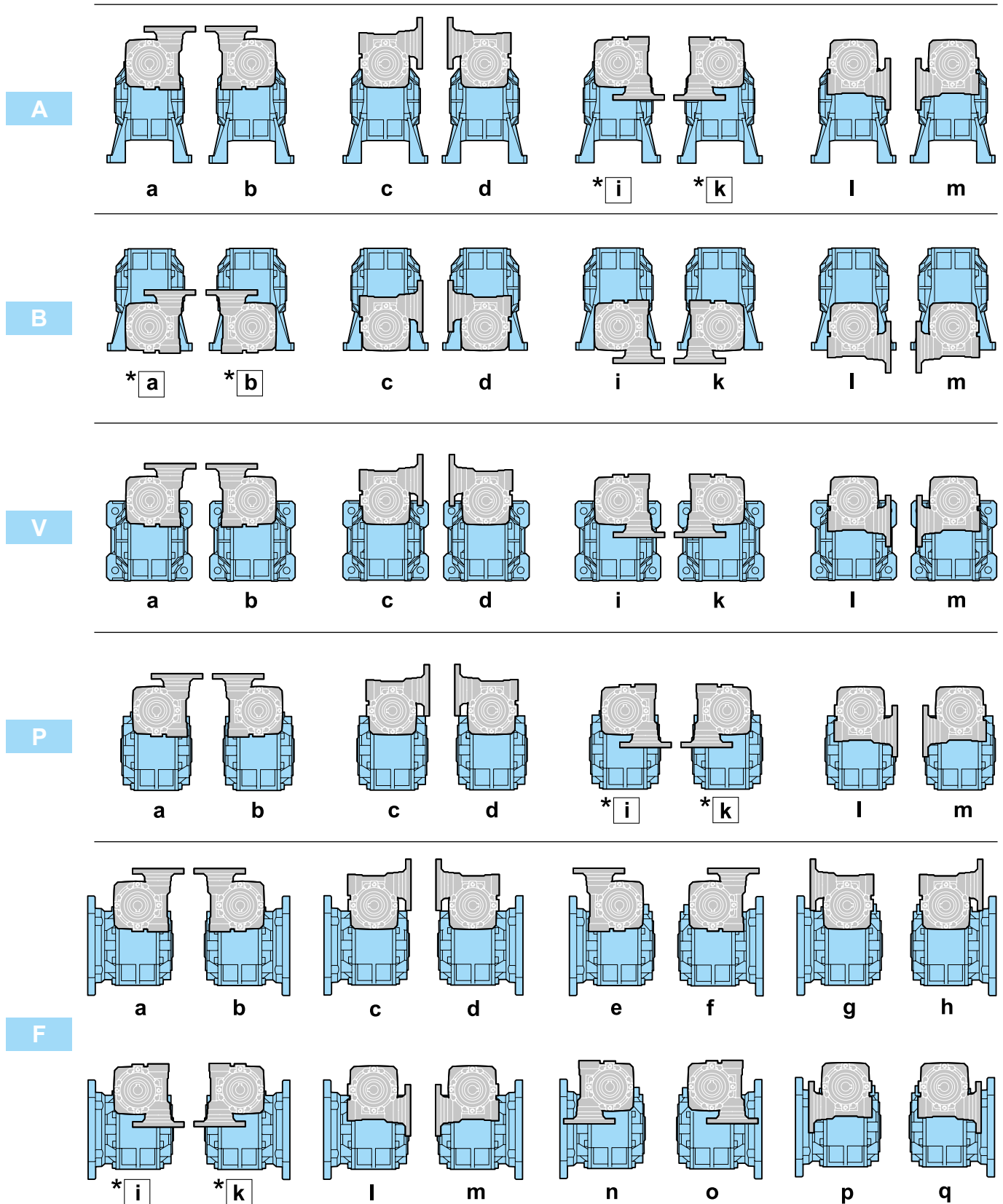

* Forma costruttiva non realizzabile su: / Version not feasible on: / Bauform nicht ausführbar für:
 30/30, 30/40, 30/50 PAM 63B5 (ø 140), 40/63 PAM 71B5 (ø 160)

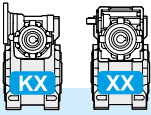

5.2 Designazione

5.2 Designation

5.2 Bezeichnung

Riduttore entrata Gearbox at input Getriebe am Antrieb	Macchina uscita Gearbox at output Getriebe am Abtrieb	Tipo entrata Input type Antriebsart	Grandezza Size Größe	Rapporto rid. Ratio Untersetzung	Predispos. att. mot. Motor coupling Motoranschluss	Versione Version Version	Forma costruttiva Execution Bauform	Posizione di mont. Mounting position Einbaulege	Limitatore di coppia. Torque limiter Drehmomentbegrenzer	Seconda entrata Additional input Zusatzantrieb	Albero uscita Output shaft Abtriebswelle	Braccio di reazione Torque arm Drehmomentstütze												
K	X	C	50/110	1200	P.A.M.	F1	a	B3	LD	SeA1	H	BR												
Riduttore a vite senza fine combinato Combined worm gearbox Doppelschneckengetriebe		C	30/30	150	56	P	ab	B3			H													
			30/40	200			cd						B6	SD										
			30/50	300			ef									B7	SS							
			30/63	450			gh												B8	DD				
			40/63	600			ik															V5	BR	
			40/75	900			lm																	V6
			40/90	1200			no																	
			40/90	1500			pq																	
			50/75	1950																				
			50/90	2500																				
			50/110	3250																				
			63/110	4000																				
			63/130	5000																				
	10000																							

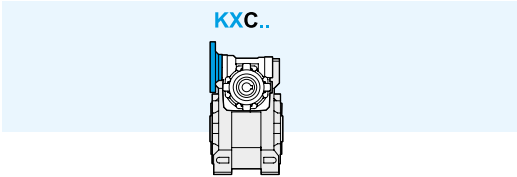

Riduttore entrata Gearbox at input Getriebe am Antrieb	Macchina uscita Gearbox at output Getriebe am Abtrieb	Tipo entrata Input type Antriebsart	Grandezza Size Größe	Rapporto rid. Ratio Untersetzung	Predispos. att. mot. Motor coupling Motoranschluss	Versione Version Version	Forma costruttiva Execution Bauform	Posizione di mont. Mounting position Einbaulege	Limitatore di coppia. Torque limiter Drehmomentbegrenzer	Seconda entrata Additional input Zusatzantrieb	Albero uscita Output shaft Abtriebswelle	Braccio di reazione Torque arm Drehmomentstütze											
X	X	C	50/110	1200	P.A.M.	F1	a	B3	LD	SeA1	H	BR											
Riduttore a vite senza fine combinato Combined worm gearbox Doppelschneckengetriebe		A	30/30	150	56	P	ab	B3			H												
			30/40	200			cd						B6	SD									
			30/50	300			ef									B7	SS						
			30/63	450			gh												B8	DD			
			40/63	600			ik															V5	BR
			40/75	900			lm																
			40/90	1200			no																
			40/90	1500			pq																
			50/75	1950																			
			50/90	2500																			
			50/110	3250																			
			63/110	4000																			
			63/130	5000																			
	10000																						

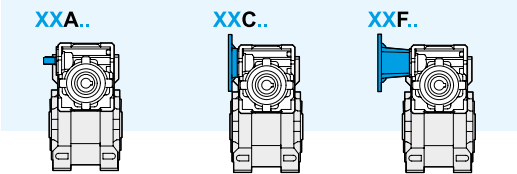

Forma costruttiva / version / Bauform

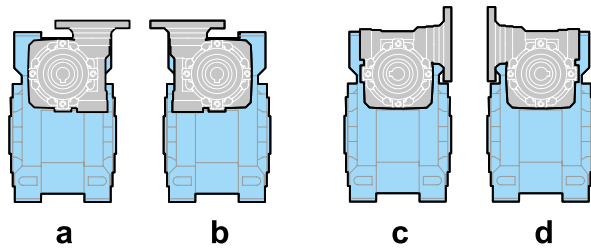

a b c d

P

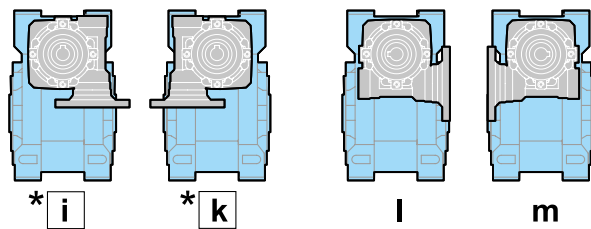

*i *k l m



Forma costruttiva non realizzabile su:
Version not feasible on:
Bauform nicht ausführbar für:

30/30, 30/40, 30/50 PAM 63B5 (ø 140),
40/63 PAM 71B5 (ø 160)

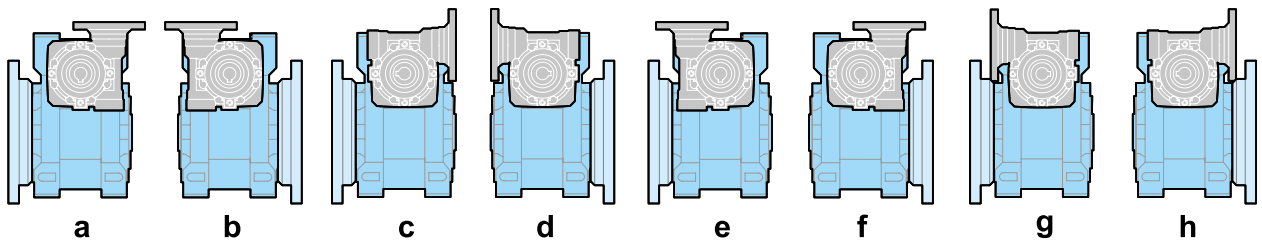

a b c d e f g h

F

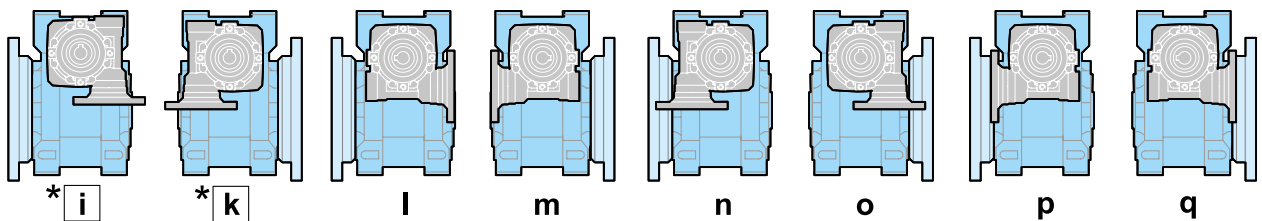

*i *k l m n o p q

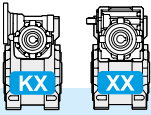

5.3 Lubrificazione e posizioni di montaggio

I riduttori a vite senza fine combinati sono forniti completi di lubrificante sintetico a base PAG con indice di viscosità ISO VG320. Si raccomanda di precisare sempre in fase di ordine la forma costruttiva e la posizione di lavoro desiderata.

5.3 Lubrication and mounting position

Combined worm gearboxes are supplied with synthetic lubricant, PAG base, viscosity index ISO VG320. Required version and mounting position always to be specified when ordering.

5.3 Schmierung und Einbaulage

Kombinierte Schneckengetriebe werden mit synthetischem Schmiermittel auf PAG Basis und Viskosität Index ISO VG320 geliefert. Im Auftrag sind immer Einbaulage und Bauform anzugeben.

F (b, d, f, h, k, m, o, q)

P (a, b, c, d, i, k, l, m)

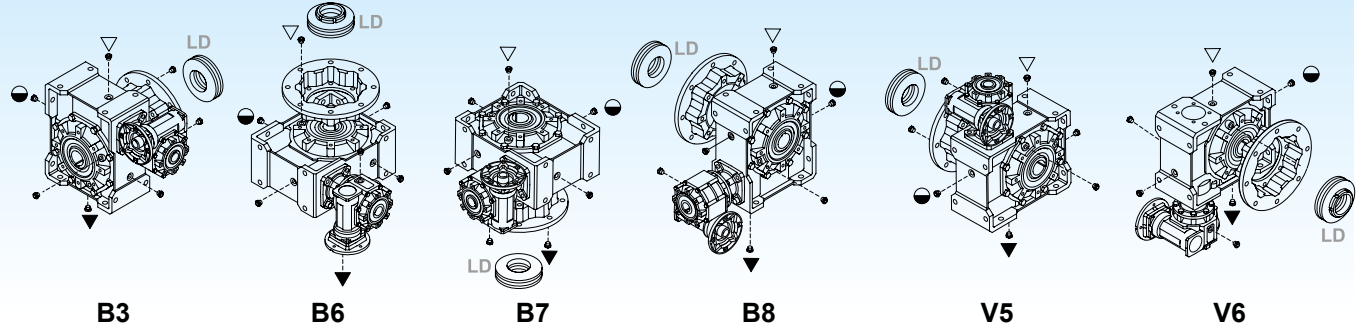

F (a, c, e, g, i, l, n, p)

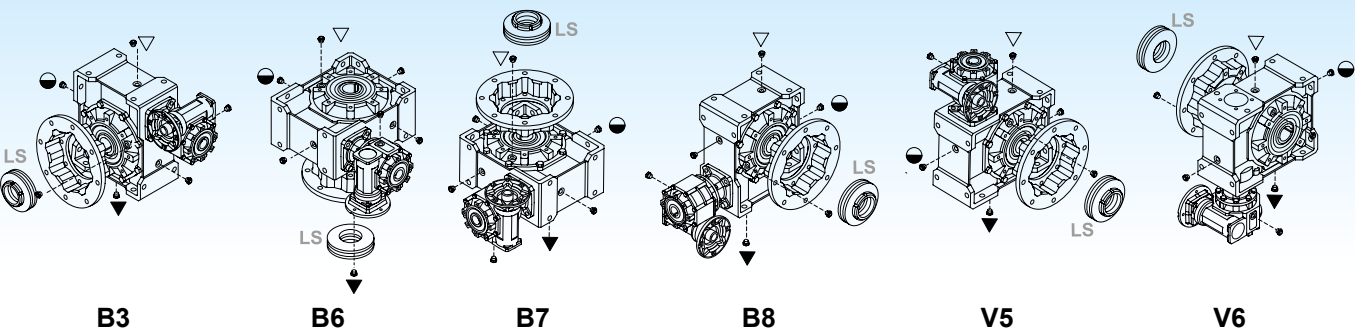

- ▽ Carico e sfiato / Filling and breather
Einfüll und Entlüftung
- Livello / Level / Ölstand
- ▼ Scarico / Drain / Ablass

Nei corpi in alluminio 30, 40, 50, 63, 75 è presente un solo tappo di riempimento olio.

Aluminium housings size 30, 40, 50, 63 and 75 have one filling plug only.

Gehäuse aus Aluminium Größe 30, 40, 50, 63 und 75 verfügen über nur eine Einfüllschraube.

		Q.tà olio / Oil quantity / Schmiermittelmenge [lt]												
		XXA - XXC - KXC - XXF												
		30/30	30/40	30/50	30/63	40/63	40/75	40/90	50/75	50/90	50/110	63/110	63/130	
Posizioni di montaggio Mounting positions Einbaulage	B3	IN	0.015				0.04			0.08			0.16	0.4
		OUT	0.015	0.04	0.08	0.16	0.16	0.26	1.1	0.26	1.1	2.2	2.2	3.6
	B6	IN	0.015				0.04			0.08			0.16	0.4
		OUT	0.030	0.060	0.120	0.220	0.220	0.340	0.9	0.26	0.9	1.8	1.8	3.0
	B7	IN	0.015				0.04			0.08			0.16	0.4
		OUT	0.030	0.060	0.120	0.220	0.220	0.340	0.9	0.26	0.9	1.8	1.8	3.0
	B8	IN	0.015				0.04			0.08			0.16	0.4
		OUT	0.015	0.04	0.08	0.16	0.16	0.26	1	0.26	1	1.6	1.6	2.5
	V5	IN	0.030				0.060			0.120			0.220	0.220
		OUT	0.015	0.04	0.08	0.16	0.16	0.26	1.5	0.26	1.5	2.6	2.6	3.8
	V6	IN	0.030				0.060			0.120			0.220	0.220
		OUT	0.015	0.04	0.08	0.16	0.16	0.26	1.5	0.26	1.5	2.6	2.6	3.8

IN = Riduttore entrata / Gearbox at input / Getriebe am Antrieb
OUT = Riduttore uscita / Gearbox at output / Getriebe am Abtrieb

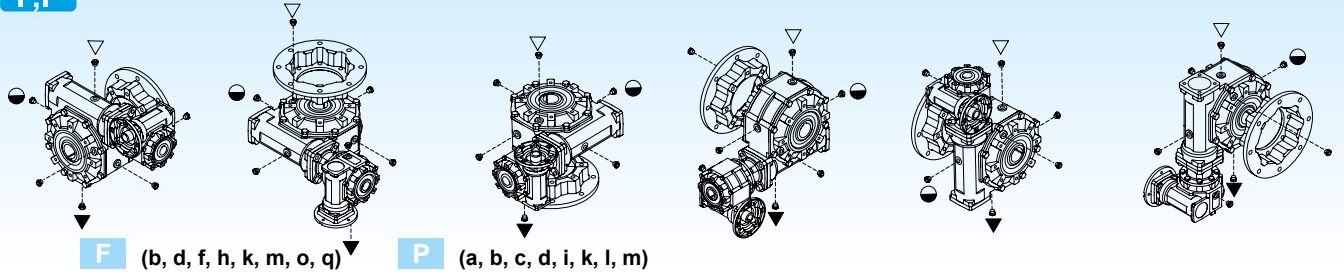
F,P

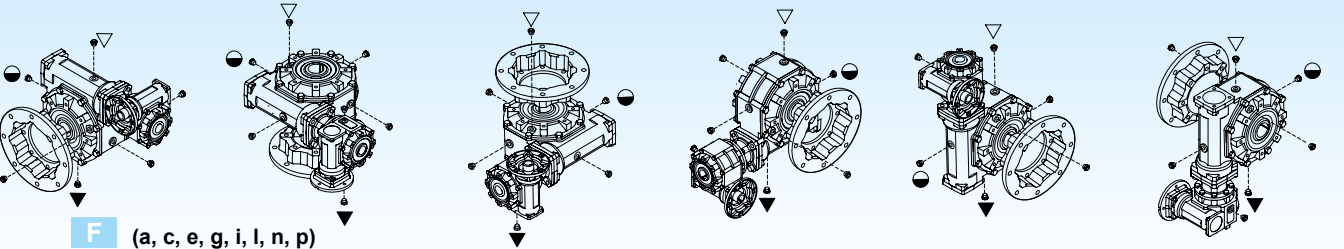
F (b, d, f, h, k, m, o, q)

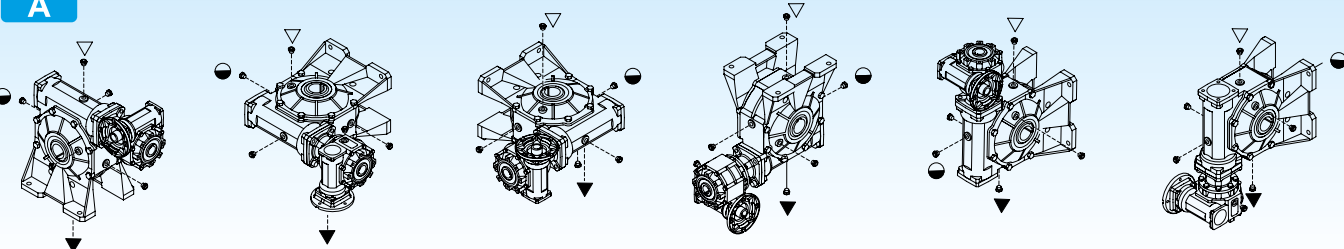
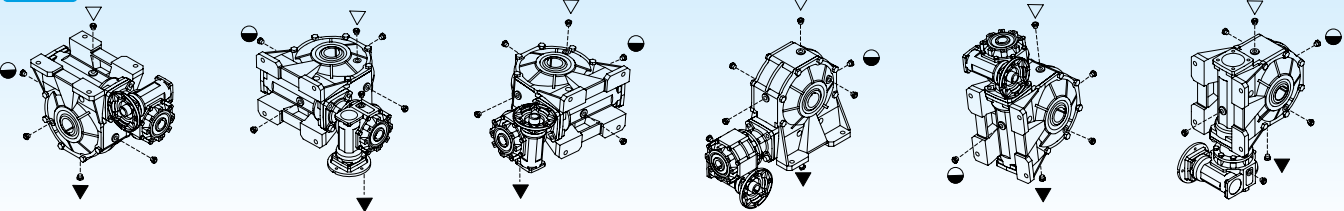
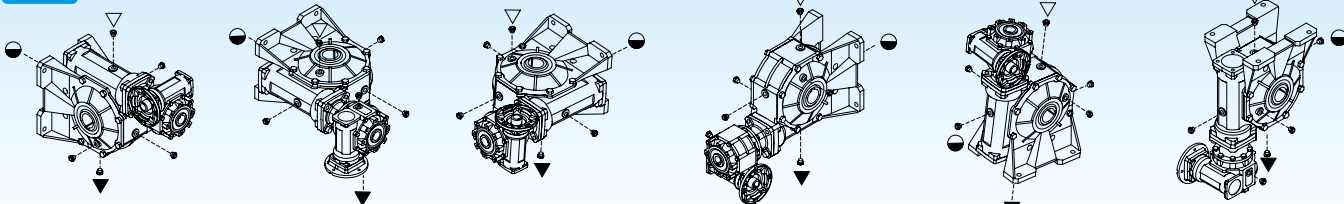
P (a, b, c, d, i, k, l, m)

F (a, c, e, g, i, l, n, p)

A

B

V

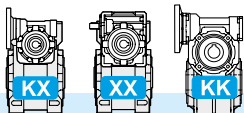
B3
B6
B7
B8
V5
V6

		Q.tà olio / Oil quantity / Schmiermittelmenge [lit]												
		Combinato tipo: KKC												
		30/30	30/40	30/50	30/63	40/63	40/75	40/90	50/75	50/90	50/110	63/110	63/130	
Posizioni di montaggio Mounting positions Einbaulage	B3	IN	0.015				0.04			0.08			0.16	0.16
		OUT	0.015	0.04	0.08	0.16	0.16	0.26	1	0.26	1	2	2	3
	B6	IN	0.015				0.04			0.08			0.16	0.4
		OUT	0.030	0.060	0.120	0.220	0.220	0.340	0.9	0.26	0.9	1.8	1.8	3.0
	B7	IN	0.015				0.04			0.08			0.16	0.4
		OUT	0.030	0.060	0.120	0.220	0.220	0.340	0.9	0.26	0.9	1.8	1.8	3.0
	B8	IN	0.015				0.04			0.08			0.16	0.16
		OUT	0.015	0.04	0.08	0.16	0.16	0.26	0.8	0.26	0.8	2	2	2.1
	V5	IN	0.030				0.060			0.120			0.220	0.220
		OUT	0.015	0.04	0.08	0.16	0.16	0.26	1.5	0.26	1.5	2.6	2.6	3.8
	V6	IN	0.030				0.060			0.120			0.220	0.220
		OUT	0.015	0.04	0.08	0.16	0.16	0.26	1.5	0.26	1.5	2.6	2.6	3.8

IN = Riduttore entrata / Gearbox at input / Getriebe am Antrieb

OUT = Riduttore uscita / Gearbox at output / Getriebe am Abtrieb



5.4 Posizione morsettiera

5.4 Terminal board position

5.4 Lage der Klemmenkaste

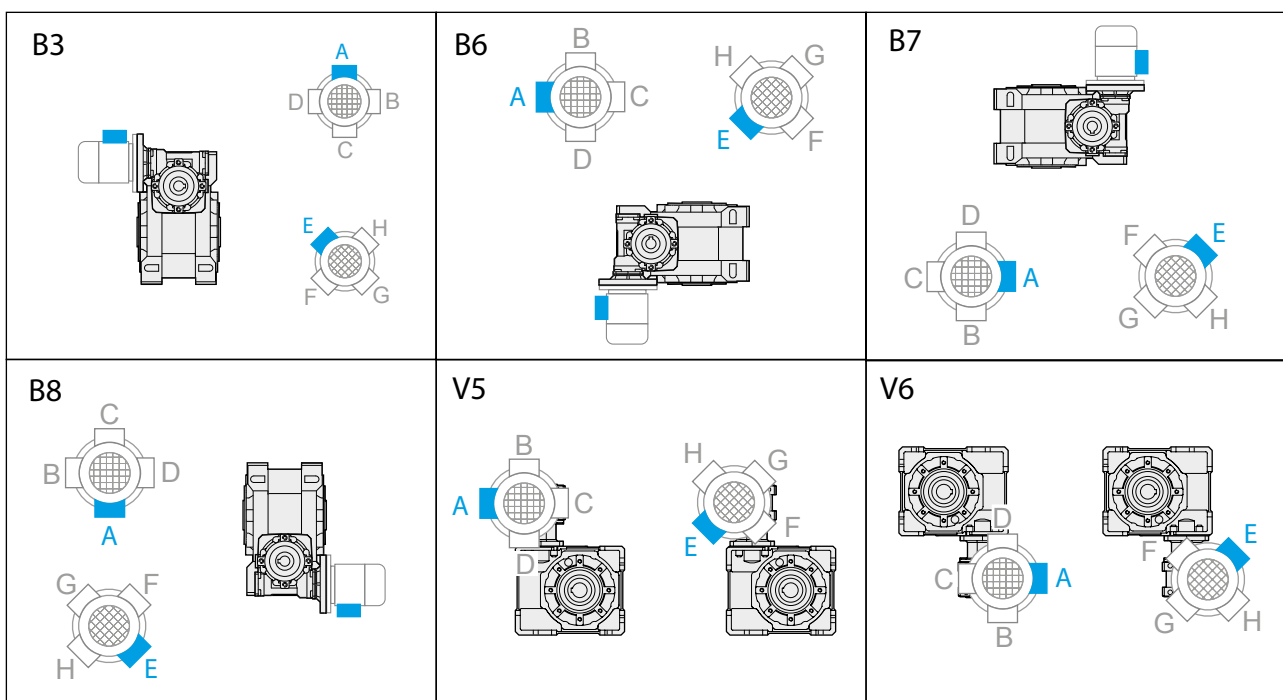

Specificare sempre in fase di ordinazione la posizione di montaggio e la forma costruttiva.
 Posizione morsettiera v. pag. 105 - 106 (PM=1; PM=2)

Mounting position always to be specified when ordering.
Terminal board position see page 105-106 (PM=1; PM=2)

Bei der Bestellung immer die gewünschte Montageposition und Bauform angeben.
 Lage der Klemmenkaste Seite 105-106 (PM=1; PM=2)

5.5 Dati tecnici

5.5 Technical data

5.5 Technische Daten

30/30	$n_1 = 1400$					XXA		KXC - XXC - XXF - KKC											
	in	30	30	n_2	Rd	T_{2M}	P	T_2	P_1	FS'	Input - IEC								
		i_1	i_2								KC - XC		XF						
											B5/B14		B5		B14				
Kg 3.0	150	10	15	9.3	0.51	37	0.070	32	0.06	1.2	—	63	56	—	63	56	—	63	56
	200		20	7.0	0.47	32	0.050	39	0.06	0.8									
	300		4.7	0.42	39	0.045	52*	0.06	0.8*										
	450	30	15	3.1	0.40	39	0.032	73*	0.06	0.5*									
	600		20	2.3	0.37	39	0.026	91*	0.06	0.4*									
	900		30	1.6	0.34	39	0.019	125*	0.06	0.3*									
	1200	40	1.2	0.30	39	0.016	149*	0.06	0.3*										
	1500	50	0.9	0.28	39	0.014	173*	0.06	0.2*										
	1950	65	0.7	0.26	39	0.011	209*	0.06	0.2*										
	2500	50	0.6	0.23	30	0.008	235*	0.06	0.1*										
	3250	65	0.4	0.21	30	0.006	283*	0.06	0.11*										
	4000	80	0.4	0.20	30	0.005	328*	0.06	0.09*										
5000	100	0.3	0.19	30	0.005	385*	0.06	0.08*											
10000	100	0.1	0.15	17	0.002	609*	0.06	0.03*											

30/40	$n_1 = 1400$					XXA		KXC - XXC - XXF - KKC											
	in	30	40	n_2	Rd	T_{2M}	P	T_2	P_1	FS'	Input - IEC								
		i_1	i_2								KC - XC		XF						
											B5/B14		B5		B14				
Kg 4.0	150	10	15	9.3	0.54	82	0.148	72	0.13	1.1	—	63	56	—	63	56	—	63	56
	200		20	7.0	0.51	76	0.110	76	0.11	1.0									
	300		4.7	0.43	82	0.094	79	0.09	1.0										
	450	30	15	3.1	0.40	82	0.067	74	0.06	1.1									
	600		20	2.3	0.37	82	0.054	92	0.06	0.9									
	900		30	1.6	0.34	82	0.039	126*	0.06	0.6*									
	1200	40	1.2	0.31	82	0.033	151*	0.06	0.5*										
	1500	50	0.9	0.29	82	0.028	176*	0.06	0.5*										
	1950	65	0.7	0.27	82	0.023	212*	0.06	0.4*										
	2500	50	0.6	0.23	68	0.017	236*	0.06	0.3*										
	3250	65	0.4	0.21	68	0.014	285*	0.06	0.24*										
	4000	80	0.4	0.20	68	0.012	330*	0.06	0.21*										
5000	100	0.3	0.19	68	0.011	387*	0.06	0.18*											
10000	100	0.1	0.15	35	0.003	626*	0.06	0.06*											

30/50	$n_1 = 1400$					XXA		KXC - XXC - XXF - KKC											
	in	30	50	n_2	Rd	T_{2M}	P	T_2	P_1	FS'	Input - IEC								
		i_1	i_2								KC - XC		XF						
											B5/B14		B5		B14				
Kg 6.0	150	10	15	9.3	0.55	149	0.265	124	0.22	1.2	—	63	56	—	63	56	—	63	56
	200		20	7.0	0.52	144	0.201	129	0.18	1.1									
	300		4.7	0.44	150	0.166	118	0.13	1.3										
	450	30	15	3.1	0.42	150	0.118	140	0.11	1.1									
	600		20	2.3	0.39	150	0.094	143	0.09	1.0									
	900		30	1.6	0.36	150	0.069	131	0.06	1.1									
	1200	40	1.2	0.32	150	0.058	156	0.06	1.0										
	1500	50	0.9	0.30	150	0.049	182	0.06	0.8										
	1950	65	0.7	0.28	150	0.041	220*	0.06	0.7*										
	2500	50	0.6	0.25	125	0.030	253*	0.06	0.5*										
	3250	65	0.4	0.23	125	0.025	305*	0.06	0.41*										
	4000	80	0.4	0.22	125	0.021	354*	0.06	0.35*										
5000	100	0.3	0.20	125	0.018	414*	0.06	0.30*											
10000	100	0.1	0.16	69	0.006	645*	0.06	0.11*											

* **ATTENZIONE:** la coppia massima utilizzabile $[T_{2M}]$ deve essere calcolata utilizzando il fattore di servizio: $T_{2M} = T_2 \times FS'$

* **WARNING:** Maximum allowable torque $[T_{2M}]$ must be calculated using the following service factor: $T_{2M} = T_2 \times FS'$

* **ACHTUNG:** das max. anwendbare Drehmoment $[T_{2M}]$ muss mit folgendem Betriebsfaktor berechnet werden: $T_{2M} = T_2 \times FS'$

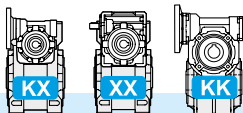

5.5 Dati tecnici

5.5 Technical data

5.5 Technische Daten

30/63	$n_1 = 1400$					XXA		KXC - XXC - XXF - KKC										
	in	30	63	n_2	Rd	T_{2M}	P	T_2	P_1	FS'	Input - IEC							
		i_1	i_2	[min ⁻¹]	[Nm]	[kW]	[Nm]	[kW]	KC - XC				XF					
									B5/B14		B5		B14					
	150	15	9.3	0.56	228	0.400	126	0.22	1.8	—	63	56	—	63	56	—	63	56
	200	10	20	7.0	279	0.378	162	0.22	1.7									
	300		4.7	0.46	268	0.285	207	0.22	1.3									
	450	15	3.1	0.43	268	0.202	238	0.18	1.1									
	600	20	2.3	0.40	268	0.162	215	0.13	1.2									
	900	30	1.6	0.37	268	0.118	250	0.11	1.1									
	1200	40	1.2	0.33	268	0.099	243	0.09	1.1									
	1500	50	0.9	0.31	268	0.085	189	0.06	1.4									
	1950	65	0.7	0.29	268	0.071	228	0.06	1.2									
	2500	50	0.6	0.26	222	0.050	265	0.06	0.8									
	3250	65	0.4	0.24	222	0.042	319*	0.06	0.70*									
	4000	80	0.4	0.23	222	0.036	369*	0.06	0.60*									
	5000	100	0.3	0.21	222	0.031	433*	0.06	0.51*									
	10000	100	0.1	0.16	138	0.012	663*	0.06	0.21*									

8.5

40/63	$n_1 = 1400$					XXA		KXC - XXC - XXF - KKC										
	in	40	63	n_2	Rd	T_{2M}	P	T_2	P_1	FS'	Input - IEC							
		i_1	i_2	[min ⁻¹]	[Nm]	[kW]	[Nm]	[kW]	KC - XC				XF					
									B5/B14		B5		B14					
	150	15	9.3	0.56	261	0.452	214	0.37	1.2	—	63	71	63	56	71	63	—	
	200	10	20	7.0	279	0.373	277	0.37	1.0									
	300		4.7	0.46	268	0.282	238	0.25	1.1									
	450	15	3.1	0.44	268	0.197	244	0.18	1.1									
	600	20	2.3	0.43	268	0.154	226	0.13	1.2									
	900	30	1.6	0.38	268	0.115	257	0.11	1.0									
	1200	40	1.2	0.36	268	0.091	264	0.09	1.0									
	1500	50	0.9	0.33	268	0.079	203	0.06	1.3									
	1950	65	0.7	0.30	268	0.067	241	0.06	1.1									
	2500	50	0.6	0.28	222	0.047	284	0.06	0.8									
	3250	65	0.4	0.25	222	0.039	338*	0.06	0.66*									
	4000	80	0.4	0.24	222	0.033	400*	0.06	0.55*									
	5000	100	0.3	0.23	222	0.028	471*	0.06	0.47*									
	10000	100	0.1	0.18	138	0.011	722*	0.06	0.19*									

9.5

* **ATTENZIONE:** la coppia massima utilizzabile $[T_{2M}]$ deve essere calcolata utilizzando il fattore di servizio: $T_{2M} = T_2 \times FS'$

* **WARNING:** Maximum allowable torque $[T_{2M}]$ must be calculated using the following service factor: $T_{2M} = T_2 \times FS'$

* **ACHTUNG:** das max. anwendbare Drehmoment $[T_{2M}]$ muss mit folgendem Betriebsfaktor berechnet werden: $T_{2M} = T_2 \times FS'$

5.5 Dati tecnici

5.5 Technical data

5.5 Technische Daten

40/75	$n_1 = 1400$					XXA		KXC - XXC - XXF - KKC												
	in	40	75	n_2	Rd	T_{2M}	P	T_2	P_1	FS'	Input - IEC									
		i_1	i_2								KC - XC		XF							
											B5/B14		B5		B14					
	150	10	15	9.3	0.57	409	0.698	322	0.55	1.3	71	63	—	71	63	56	71	63	—	
	200		20	7.0	0.56	442	0.583	417	0.55	1.1										
	300			4.7	0.47	418	0.432	358	0.37	1.2										
	450	15		3.1	0.45	418	0.302	346	0.25	1.2										
	600	20		2.3	0.43	418	0.236	390	0.22	1.1										
	900	30	30	1.6	0.39	418	0.176	309	0.13	1.4										
	1200	40		1.2	0.36	418	0.140	388	0.13	1.1										
	1500	50		0.9	0.34	418	0.121	379	0.11	1.1										
	1950	65		0.7	0.31	418	0.102	368	0.09	1.1										
	2500	50		0.6	0.29	381	0.077	296	0.06	1.3										
	3250	65	50	0.4	0.26	381	0.065	352	0.06	1.08	—	56								
	4000	80		0.4	0.25	381	0.055	417	0.06	0.91										
	5000	100		0.3	0.24	381	0.047	491*	0.06	0.78*										
	10000	100	100	0.1	0.19	232	0.018	762*	0.06	0.30*										

14.5

50/75	$n_1 = 1400$					XXA		KXC - XXC - XXF - KKC												
	in	50	75	n_2	Rd	T_{2M}	P	T_2	P_1	FS'	Input - IEC									
		i_1	i_2								KC - XC		XF							
												B5/B14		B5		B14				
	150	10	15	9.3	0.57	409	0.750	409	0.75	1.0	80	71	—	80	71	63	80	71	—	
	200		20	7.0	0.56	442	0.576	422	0.55	1.0										
	300			4.7	0.48	418	0.427	363	0.37	1.2										
	450	15		3.1	0.46	418	0.299	350	0.25	1.2										
	600	20		2.3	0.42	418	0.250	418	0.25	1.0										
	900	30	30	1.6	0.40	418	0.180	418	0.18	1.0										
	1200	40		1.2	0.38	418	0.134	406	0.13	1.0										
	1500	50		0.9	0.35	418	0.116	470	0.13	0.9										
	1950	65		0.7	0.33	418	0.095	572*	0.13	0.7*										
	2500	50		0.6	0.30	381	0.074	674*	0.13	0.6*										
	3250	65	50	0.4	0.28	381	0.060	819*	0.13	0.47*	—	63								
	4000	80		0.4	0.26	381	0.053	939*	0.13	0.41*										
	5000	100		0.3	0.25	381	0.045	1108*	0.13	0.34*										
	10000	100	100	0.1	0.19	232	0.018	1719*	0.13	0.13*										

16.5

* **ATTENZIONE:** la coppia massima utilizzabile $[T_{2M}]$ deve essere calcolata utilizzando il fattore di servizio: $T_{2M} = T_2 \times FS'$

* **WARNING:** Maximum allowable torque $[T_{2M}]$ must be calculated using the following service factor: $T_{2M} = T_2 \times FS'$

* **ACHTUNG:** das max. anwendbare Drehmoment $[T_{2M}]$ muss mit folgendem Betriebsfaktor berechnet werden: $T_{2M} = T_2 \times FS'$

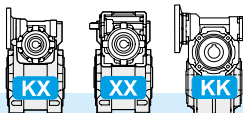

5.5 Dati tecnici

5.5 Technical data

5.5 Technische Daten

40/90	$n_1 = 1400$					XXA		KXC - XXC - XXF - KKC																				
	in	40	90	n_2	Rd	T_{2M}	P	T_2	P_1	FS'	Input - IEC																	
		i_1	i_2								KC - XC				XF													
											B5/B14		B5		B14													
	150		15	9.3	0.58	435	0.732	327	0.55	1.3	71	63	—	71	63	56	71	63	—									
	200	10	20	7.0	0.56	560	0.727	424	0.55	1.3																		
	300			4.7	0.48	673	0.683	542	0.55	1.2																		
	450	15		3.1	0.46	673	0.478	520	0.37	1.3																		
	600	20		2.3	0.44	673	0.373	668	0.37	1.0																		
	900	30	30	1.6	0.39	673	0.278	605	0.25	1.1																		
	1200	40		1.2	0.37	673	0.221	668	0.22	1.0																		
	1500	50		0.9	0.34	660	0.188	630	0.18	1.0																		
	1950	65		0.7	0.31	620	0.149	542	0.13	1.1																		
	2500	50		0.6	0.30	634	0.124	564	0.11	1.1																		
	3250	65	50	0.4	0.28	634	0.104	549	0.09	1.15										—	56							
	4000	80		0.4	0.27	634	0.088	651	0.09	0.97																		
	5000	100		0.3	0.25	634	0.074	767	0.09	0.83																		
	10000	100	100	0.1	0.19	401	0.031	1173*	0.09	0.34*																		



27

50/90	$n_1 = 1400$					XXA		KXC - XXC - XXF - KKC																			
	in	50	90	n_2	Rd	T_{2M}	P	T_2	P_1	FS'	Input - IEC																
		i_1	i_2								KC - XC				XF												
											B5/B14		B5		B14												
	150		15	9.3	0.59	655	1.089	541	0.90	1.2	80	71	—	80	71	63	80	71	—								
	200	10	20	7.0	0.57	709	0.910	584	0.75	1.2																	
	300			4.7	0.49	673	0.675	548	0.55	1.2																	
	450	15		3.1	0.46	673	0.473	527	0.37	1.3																	
	600	20		2.3	0.45	673	0.363	463	0.25	1.5																	
	900	30	30	1.6	0.41	673	0.266	632	0.25	1.1																	
	1200	40		1.2	0.39	673	0.212	573	0.18	1.2																	
	1500	50		0.9	0.36	673	0.183	662	0.18	1.0																	
	1950	65		0.7	0.34	673	0.150	582	0.13	1.2																	
	2500	50		0.6	0.32	634	0.118	701	0.13	0.9																	
	3250	65	50	0.4	0.30	634	0.097	853*	0.13	0.74*										—	63						
	4000	80		0.4	0.28	634	0.084	977*	0.13	0.65*																	
	5000	100		0.3	0.26	634	0.071	1153*	0.13	0.55*																	
	10000	100	100	0.1	0.20	401	0.030	1764*	0.13	0.23*																	



29

* **ATTENZIONE:** la coppia massima utilizzabile $[T_{2M}]$ deve essere calcolata utilizzando il fattore di servizio: $T_{2M} = T_2 \times FS'$

* **WARNING:** Maximum allowable torque $[T_{2M}]$ must be calculated using the following service factor: $T_{2M} = T_2 \times FS'$

* **ACHTUNG:** das max. anwendbare Drehmoment $[T_{2M}]$ muss mit folgendem Betriebsfaktor berechnet werden: $T_{2M} = T_2 \times FS'$

5.5 Dati tecnici

5.5 Technical data

5.5 Technische Daten

50/110	$n_1 = 1400$					XXA		KXC - XXC - XXF - KKC										
	in	50	110	n_2	Rd	T_{2M}	P	T_2	P_1	FS'	Input - IEC							
		i_1	i_2								KC - XC		XF					
											B5/B14		B5		B14			
	150		15	9.3	0.60	785	1.269	557	0.9	1.4	80	71	80	71	63	80	71	—
	200	10	20	7.0	0.58	1000	1.265	712	0.9	1.4								
	300			4.7	0.50	1165	1.130	928	0.9	1.3								
	450	15		3.1	0.48	1165	0.791	1105	0.75	1.1								
	600	20		2.3	0.47	1165	0.608	1054	0.55	1.1								
	900	30	30	1.6	0.43	1165	0.445	968	0.37	1.2								
	1200	40		1.2	0.40	1165	0.354	823	0.25	1.4								
	1500	50		0.9	0.37	1165	0.306	952	0.25	1.2								
	1950	65		0.7	0.35	1150	0.248	1018	0.22	1.1								
	2500	50		0.6	0.33	1119	0.200	1009	0.18	1.1								
	3250	65	50	0.4	0.31	1119	0.164	886	0.13	1.26								
	4000	80		0.4	0.29	1119	0.143	1015	0.13	1.10								
	5000	100		0.3	0.27	1119	0.121	1198	0.13	0.93								
	10000	100	100	0.1	0.21	727	0.051	1854*	0.13	0.39*								

49

63/110	$n_1 = 1400$					XXA		KXC - XXC - XXF - KKC										
	in	63	110	n_2	Rd	T_{2M}	P	T_2	P_1	FS'	Input - IEC							
		i_1	i_2								KC - XC		XF					
											B5/B14		B5		B14			
	150		15	9.3	0.61	1123	1.793	939	1.5	1.2	90	80	90	80	71	90	80	—
	200	10	20	7.0	0.59	1229	1.536	1200	1.5	1.0								
	300			4.7	0.51	1165	1.116	1148	1.1	1.0								
	450	15		3.1	0.49	1165	0.781	1119	0.75	1.0								
	600	20		2.3	0.48	1165	0.593	1081	0.55	1.1								
	900	30	30	1.6	0.44	1165	0.433	995	0.37	1.2								
	1200	40		1.2	0.40	1165	0.370	1165	0.37	1.0								
	1500	50		0.9	0.39	1165	0.292	998	0.25	1.2								
	1950	65		0.7	0.37	1165	0.239	1217	0.25	1.0								
	2500	50		0.6	0.34	1119	0.190	1469	0.25	0.8								
	3250	65	50	0.4	0.32	1119	0.156	1792*	0.25	0.62*								
	4000	80		0.4	0.31	1119	0.133	2097*	0.25	0.53*								
	5000	100		0.3	0.28	1119	0.117	2395*	0.25	0.47*								
	10000	100	100	0.1	0.22	727	0.049	3706*	0.25	0.20*								

52

63/130	$n_1 = 1400$					XXA		KXC - XXC - XXF - KKC										
	in	63	130	n_2	Rd	T_{2M}	P	T_2	P_1	FS'	Input - IEC							
		i_1	i_2								KC - XC		XF					
											B5/B14		B5		B14			
	150		15	9.3	0.64	1438	2.2	1176	1.8	1.2	90	80	90	80	71	90	80	—
	200	10	20	7	0.61	1831	2.2	1498	1.8	1.2								
	300			4.7	0.53	1890	1.7	1627	1.5	1.2								
	450	15		3.1	0.49	1890	1.3	1655	1.1	1.1								
	600	20		2.3	0.47	1890	0.98	1731	0.9	1.1								
	900	30	30	1.6	0.42	1890	0.73	1934	0.75	1								
	1200	40		1.2	0.39	1890	0.59	1756	0.55	1.1								
	1500	50		0.9	0.36	1890	0.51	2026	0.55	0.9								
	1950	65		0.7	0.34	1890	0.42	1673	0.37	1.1								
	2500	50		0.6	0.33	1920	0.34	2082	0.37	0.9								
	3250	65	50	0.4	0.3	1920	0.29	1663	0.25	1.2								
	4000	80		0.4	0.29	1920	0.24	1978	0.25	1.1								
	5000	100		0.3	0.26	1920	0.22	2217	0.25	0.9								
	10000	100	100	0.1	0.2	1276	0.09	3411	0.25	0.4								

63

* **ATTENZIONE:** la coppia massima utilizzabile [T_{2M}] deve essere calcolata utilizzando il fattore di servizio: $T_{2M} = T_2 \times FS'$

* **WARNING:** Maximum allowable torque [T_{2M}] must be calculated using the following service factor: $T_{2M} = T_2 \times FS'$

* **ACHTUNG:** das max. anwendbare Drehmoment [T_{2M}] muss mit folgendem Betriebsfaktor berechnet werden: $T_{2M} = T_2 \times FS'$

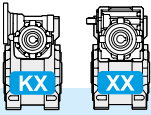

5.6 Dimensioni

5.6 Dimensions

5.6 Abmessungen

KXC

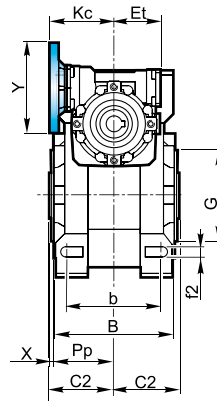
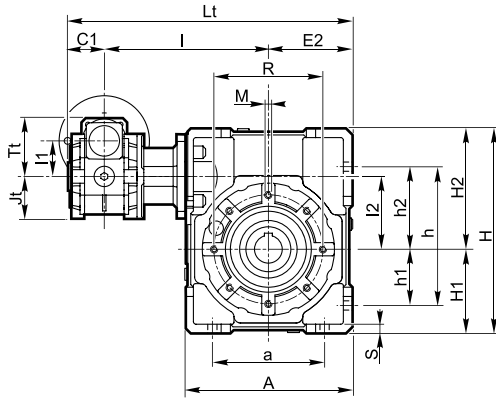

XXA

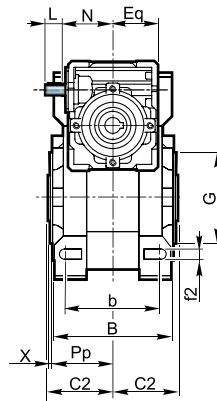
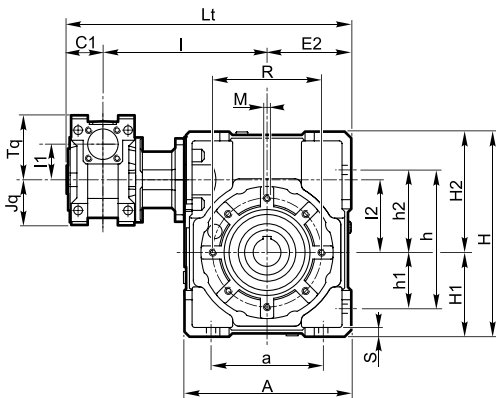

Albero entrata
Input shaft
Antriebswelle

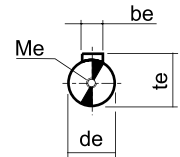

XXF

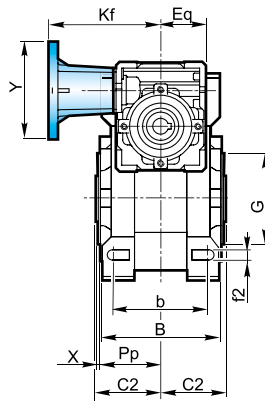
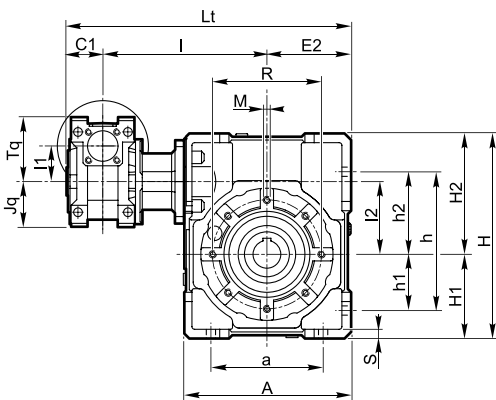

Albero uscita cavo
Output hollow shaft
Abtriebshohlwelle

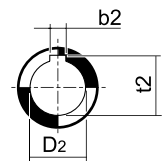

XXC

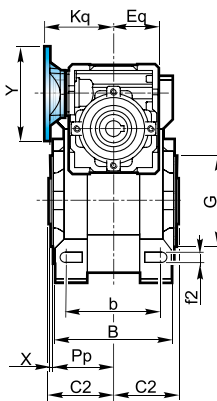
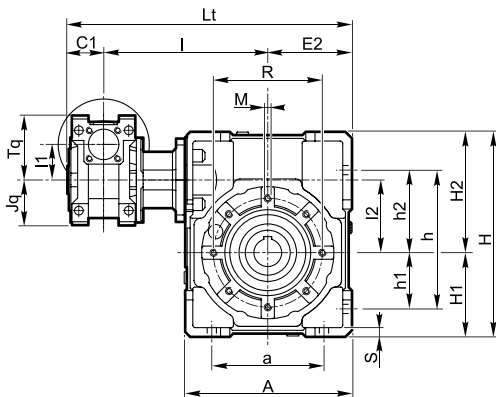

5.6 Dimensioni

5.6 Dimensions

5.6 Abmessungen

Flangia pendolare / Side cover for shaft mounting / Aufsteckflansch

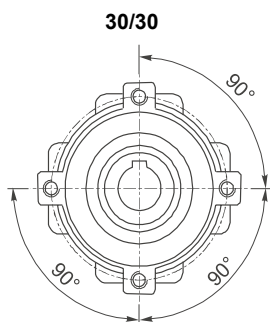

4 Fori / Holes / Bohrungen

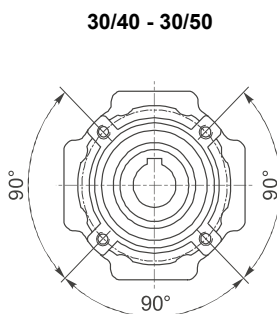

4 Fori / Holes / Bohrungen

30/63 - 40/63 - 40/75 - 40/90 - 50/75
50/90 - 50/110 - 63/110 - 63/130

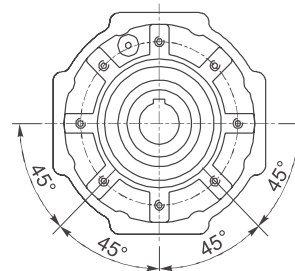

8 Fori / Holes / Bohrungen

KXC - XXC - XXF -XXA																												
	a	A	b	be	b ₂	B	C ₁	C ₂	de	D ₂ H8	Et	Eq	E ₂	f ₂	G h8	h	h ₁	h ₂	H	H ₁	H ₂							
30/30	54	80	44	3	5	—	56	31.5	31.5	14	—	41	40	40	6.5	55	71	27	44	97	40	57						
30/40	70	105	60		6	6	71		39					9	18	19	51	50	50	6.5	60	90	35	55	125	50	75	
30/50	80	125	70		8	8	85		46						24	60			8.5	70	104	40	64	150	60	90		
30/63 40/63	100	147	85	4	8	—	103	39	56	25	—	51	50	72	9	80	130	50	80	182	72	110						
40/75 50/75	120	176	90		8	8	112		46					60	14	28	30	60	60	86	11	95	153	60	93	219.5	86	133.5
40/90 50/90	140	203	100		10	—	130		39					70	11	35	—	51	50	103	13	110	172	70	102	248.5	103	145.5
50/110	170	252.5	115	6	12	—	143	46	77.5	14	—	60	60	127.5	14	130	210	85	125	310.5	127.5	183						
63/110																							56	19	71	72		
63/130	200	292.5	120	6	14	14	155	56	85	19	45	48	—	72	147.5	15	180	240	100	140	355	147.5	207.5					

KXC - XXC - XXF -XXA																								
	l	l ₁	l ₂	Jt	Jq	K _c	K _q	L	L _t	M	Me	N	P _P	R	S	Tt	Tq	t _e	t ₂	X				
30/30	100	31.5	31.5	37.5	40	57	57	15	171.5	M6x8	M4x10	44.5	29	65	5.5	52.5	57	10.2	16.3	—	1.5			
30/40	122		40						203.5	M6x10			36.5	75	6				20.8	21.8	1.5			
30/50	132		50						223.5	M8x10			43.5	85	7				27.3	27.3	1.5			
30/63	145	63	63	43.5	50	75	75	20	248.5	M8x14	M4x12	57.5	53	95	8	68.5	75	12.5	28.3	—	2			
40/63	150								261	M8x14			57	115	10				82.5	90	16	31.3	33.3	2
40/75	174.5								299.5															
50/75	190	50	75	53.5	60	82	82	25	322	M8x14	M5x13	67.5	67	130	12	68.5	75	12.2	38.3	—	2			
40/90	184.5	40	90	43.5	50	75	75	20	326.5	M10x18	M4x12	57.5	67	130	12	68.5	75	12.2	38.3	—	2			
50/90	200	50	90	53.5	60	82	82	25	349	M10x18	M5x13	67.5	74	165	14	82.5	90	16	45.3	—	2.5			
50/110	226								399.5													M10x18	77.5	
63/110	236								63	110	64	72	97	95	30	419.5	M8x20	M8x20	77.5	81	215			15
63/130	256	63	130	—	72	97	95	30	459.5	M12x20	M8x20	77.5	81	215	15	—	110	21.5	48.8	51.8	3			

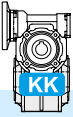

5.6 Dimensioni

5.6 Dimensions

5.6 Abmessungen

KKC_A

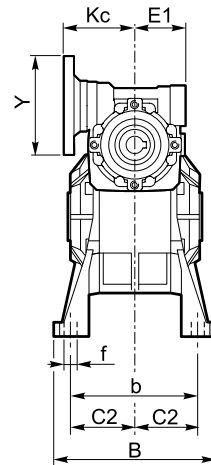
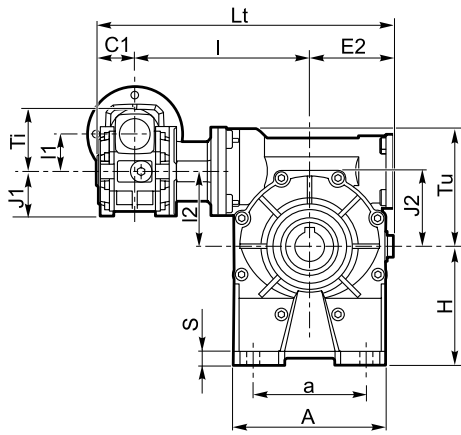

KKC_B

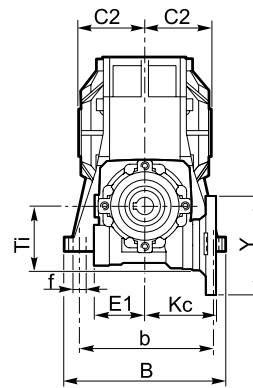
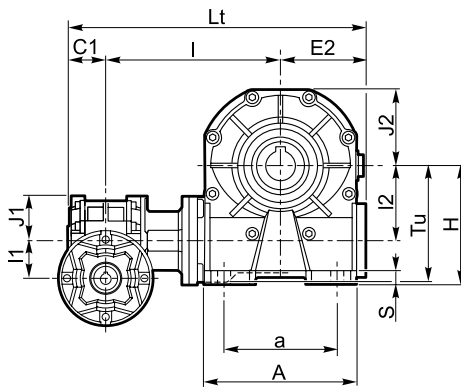

KKC_V

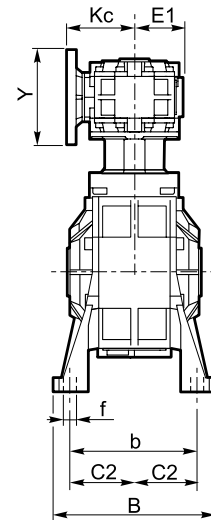
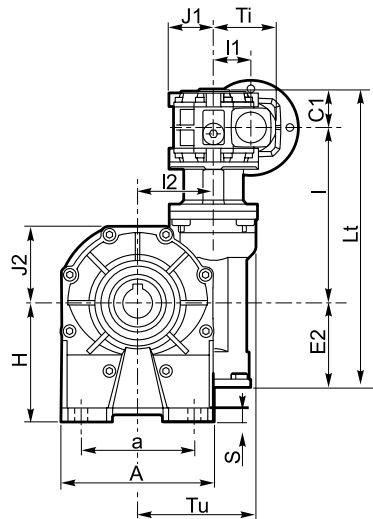

KKC_P

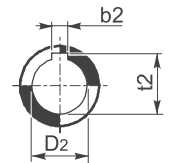
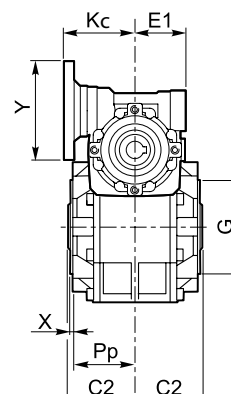
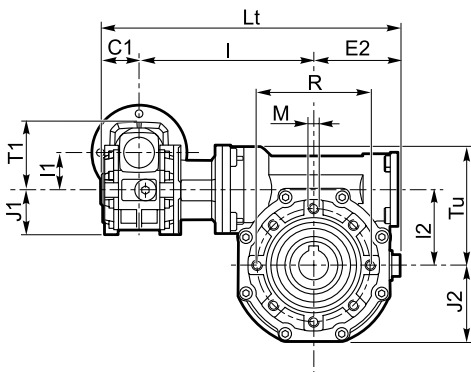

Albero uscita cavo
Output hollow shaft
Abtriebs-Hohlwelle

5.6 Dimensioni

5.6 Dimensions

5.6 Abmessungen

Flangia pendolare / Side cover for shaft mounting / Aufsteckflansch

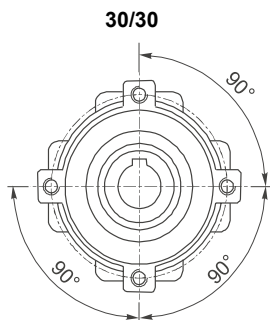

4 Fori / Holes / Bohrungen

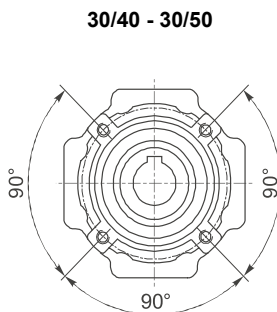

4 Fori / Holes / Bohrungen

30/63 - 40/63 - 40/75 - 40/90 - 50/75
50/90 - 50/110 - 63/110 - 60/130

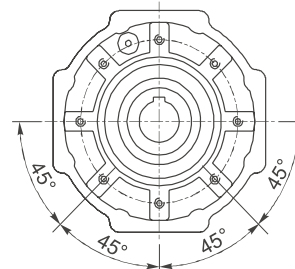

8 Fori / Holes / Bohrungen

	KKC																						
	A		a		B		b		f		H		S		b ₂	C ₁	C ₂	D2 H8	E ₁	E ₂	G h8		
	1	2	1	2	1	2	1	2	1	2	1	2	1	2									
30/30	67		40-52		78		66		6.5		52	55	5	8	5	—	31.5	14	—	41	55		
30/40	86.5		70	52	98		84	81	7	8.5	71	72	6	6	6	—	39	18	19	51	60		
30/50	106		63-85		119		99		9		85	82	8	8	8	—	46	25	24	60	70		
30/63	127.5		95		136		111		11		100		12	8	—		56	25	—	51	71	80	
40/63																							
40/75	155.5		120		140		115		11		115		12	8	—		39	60	28	30	60	85	95
50/75																							
40/90	190		140		168		140	146	13	11	135	142		14	10	—	39	70	35	—	51	103	110
50/90																							
50/110	250		200		210		162	181	13	13	171	170	17	15	12	—	46	77.5	42	—	60	127.5	130
63/110																							
63/130	295		235	220	229		190	191		15		200	195	20	15	14	56	85	45	48	71	147.5	180

	KKC															
	I	I ₁	I ₂	J ₁	J ₂	K _c	L _t	M	P _p	R	T _i	T _u	t ₂	X		
30/30	100	31.5	31.5	37.5	37.5	57	171.5	M6x8	29	65	52.5	Tu	16.3	—	1.5	
30/40	122		40				43.5	203.5	M6x10	36.5		75	52.5	20.8	21.8	1.5
30/50	132		50				53.5	223.5	M8x10	43.5		85	68.5	27.3	1.5	
30/63	147	40	63	64	75	82	248.5	M8x14	53	95	82.5	100.5	28.3	—	2	
40/63	152						261									
40/75	176.5	50	75	78	82	82	301.5	M8x14	57	115	82.5	116.5	31.3	—	2	
50/75	192						324									
40/90	186.5	40	90	100	75	82	328.5	M10x18	67	130	68.5	116.5	38.3	—	2	
50/90	202						351									
50/110	226	50	110	122	82	97	399.5	M10x18	74	165	82.5	131.5	45.3	—	2.5	
63/110	236						64									419.5
63/130	256	63	130	64	131	97	459.5	M12x20	81	215	100.5	181	48.8	51.8	3	

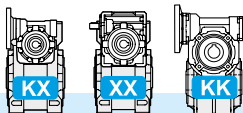

5.6 Dimensioni

5.6 Dimensions

5.6 Abmessungen

Flangia uscita / Output flange / Abtriebsflansch

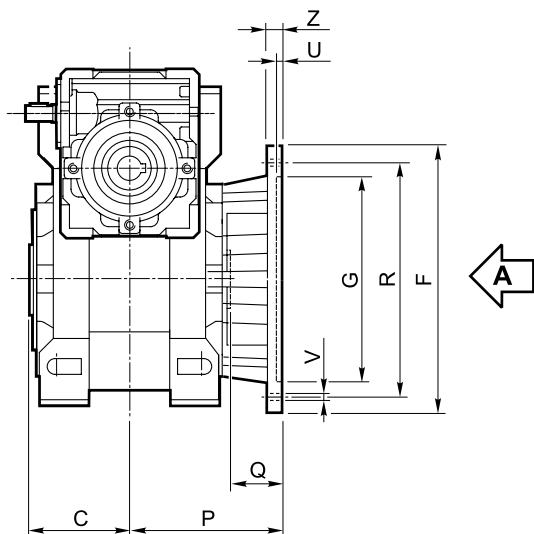

Vista da A / View from A / Ansicht von A

30/30		63/130	
F1		F1	
—		F2	
—		—	
30/30		63/130	
30/40	30/50		
F1	F1	—	—
F2	—	—	F2
—	—	F3	—
30/40 - 30/50			
30/63	40/75		
40/63	50/75	—	—
F1	F1	—	F2
F2	—	—	—
—	—	F3	—
30/63 - 40/63 - 40/75 - 50/75			
40/90	50/110		
50/90	63/110	—	—
—	F1	F1	—
—	—	—	F2
—	—	—	F3
40/90 - 50/90 - 50/110 - 63/110			

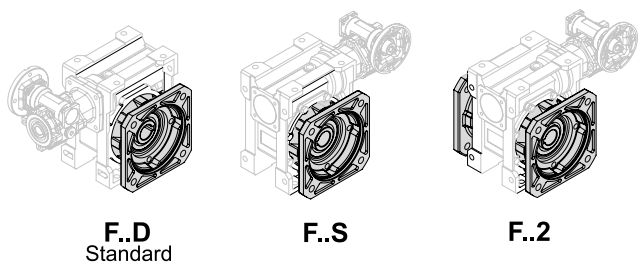

KX XX KK	Tipo Type Typ	C	F		G H8	P	Q	R	U	V			Z
												∅	
30/30	F1	31.5		66	50	54.5	23	68	4	n° 4		6.5	6
	F2												
	F3												
30/40	F1	39		85	60	67	28	75-90	4	n° 4		9	8
	F2			85	60	97	58	75-90	4	n° 4		9	8
	F3		140		95	80	41	115	5		n° 7	9	10
30/50	F1	46		94	70	90	44	85-100	5	n° 4		11	10
	F2			160	110	89	43	130	5		n° 7	11	11
	F3												
30/63 40/63	F1	56		142	115	82	26	150	5	n° 4		11	11
	F2			142	115	112	56	150	5	n° 4		11	11
	F3		160		110	80.5	24.5	130	5	n° 4		11	12
40/75 50/75	F1	60		160	130	111	51	165	5	n° 4		13	12
	F2			160	110	90	30	130	6	n° 4		11	13
	F3												
40/90 50/90	F1	70	200		152	111	41	175	5	n° 4		13	12
	F2		200		152	151	81	175	5	n° 4		13	13
	F3		200		130	110	40	165	6	n° 4		11	11
50/110 63/110	F1	77.5	260		170	131	53.5	230	6		n° 8	13	15
	F2		250		180	150	72.5	215	5	n° 4		15	16
	F3												
63/130	F1	85	320		180	140	55	255	7		n° 8 *	16	16
	F2		300	230	265								
	F3												

* Foratura ruotata di 22.5°

* Drilling turned of 22.5°

* Durchbohrung 22.5° versetzt

5.6 Dimensioni

5.6 Dimensions

5.6 Abmessungen

Flangia entrata / Input flange / Antriebsflansch

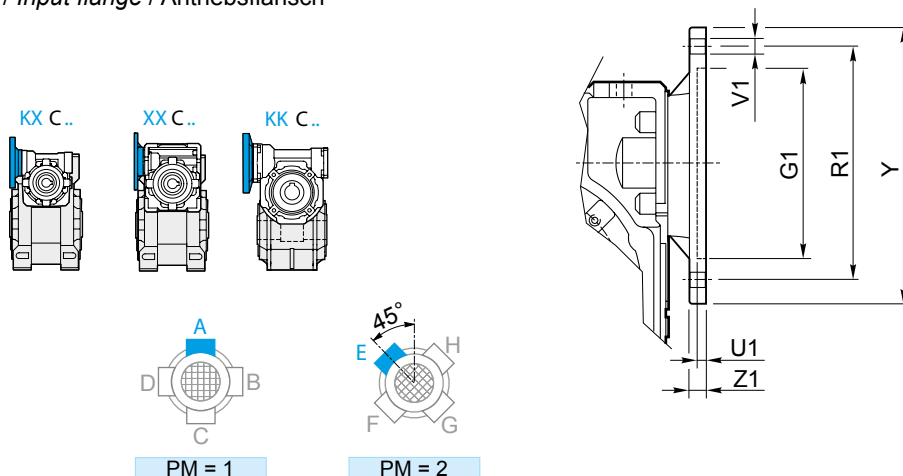

KXC XXC KKC	IEC	G ₁	PM		R ₁	U ₁	V ₁			Y	Z ₁	Diametro fori PAM / Holes diameter IEC IEC Durchmesser																					
			1	2			Ø						150	200	300	450	600	900	1200	1500	1950	2500	3250	4000	5000	10000							
30/30 30/40 30/50 30/63	56 B5	80	•	•	100	4	7			8		120	8	9	9	9	9	9	9	9	9	9	9	9	9	9	9	9	9	9	9		
	56 B14	50	•	•	65	3.5	6			8		80	8	9	9	9	9	9	9	9	9	9	9	9	9	9	9	9	9	9	9		
	63 B5	95	•	•	115	4	9			8		140	8	11	11	11	11	11	11	11	11	11	11	11	11	11	11	11	11	11	11		
	63 B14	60	•	•	75	4	6			8		90	8	11	11	11	11	11	11	11	11	11	11	11	11	11	11	11	11	11	11	11	
40/63 40/75 40/90	56 B5	80	•	•	100	4	7			8		120	9	/	/	/	/	/	/	/	/	9	9	9	9	9	9	9	9	9	9		
	56 B14	50	•	•	65	3.5	6			8	4	80	8	/	/	/	/	/	/	/	/	9	9	9	9	9	9	9	9	9	9		
	63 B5	95	•	•	115	4	9			8		140	9	11	11	11	11	11	11	11	11	11	11	11	11	11	11	11	11	11	11		
	63 B14	60	•	•	75	3.5	6			8	4	90	8	11	11	11	11	11	11	11	11	11	11	11	11	11	11	11	11	11	11	11	
	71 B5	110	•	•	130	4.5	9			8		160	10	14	14	14	14	14	14	14	14	14	/	/	/	/	/	/	/	/	/	/	
71 B14	70	•	•	85	3.5	7			8		105	8	14	14	14	14	14	14	14	14	14	/	/	/	/	/	/	/	/	/	/		
50/75 50/90 50/110	63 B5	95	•	•	115	4	9			8		140	9	/	/	/	/	/	11	11	11	11	11	11	11	11	11	11	11	11	11	11	
	63 B14	60	•	•	75	3.5	6			8	4	90	8	/	/	/	/	/	11	11	11	11	11	11	11	11	11	11	11	11	11	11	
	71 B5	110	•	•	130	4.5	9			8		160	10	14	14	14	14	14	14	14	14	14	14	14	14	14	14	14	14	14	14	14	14
	71 B14	70	•	•	85	3.5	7			8	4	105	8	14	14	14	14	14	14	14	14	14	14	14	14	14	14	14	14	14	14	14	14
	80 B5	130	•	•	165	4.5	11			8		200	10	19	19	19	19	19	19	19	19	19	/	/	/	/	/	/	/	/	/	/	
80 B14	80	•	•	100	4	7			8		120	10	19	19	19	19	19	19	19	19	19	/	/	/	/	/	/	/	/	/	/		
63/110 63/130	71 B5	110	•	•	130	4.5	9			8		160	10	/	/	/	/	/	14	14	14	14	14	14	14	14	14	14	14	14	14	14	
	71 B14	70	•	•	85	3.5	7			8	4	105	10	/	/	/	/	/	14	14	14	14	14	14	14	14	14	14	14	14	14	14	
	80 B5	130	•	•	165	4.5	11			8		200	10	19	19	19	19	19	19	19	19	19	19	19	19	19	19	19	19	19	19	19	19
	80 B14	80	•	•	100	4	7			8	4	120	10	19	19	19	19	19	19	19	19	19	19	19	19	19	19	19	19	19	19	19	19
	90 B5	130	•	•	165	4.5	11			8		200	10	24	24	24	24	24	24	24	24	24	/	/	/	/	/	/	/	/	/	/	
90 B14	95	•	•	115	4	8.5			8		140	10	24	24	24	24	24	24	24	24	24	/	/	/	/	/	/	/	/	/	/		

N.B.: E' possibile realizzare anche tutte le composizioni ibride ottenibili dalle flange esistenti.

N.B.: it is possible to create hybrid combinations with the existing flanges.

ANMERKUNG: Mischkombinationen mit der verfügbaren Flanschen sind möglich.

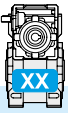

5.6 Dimensioni

5.6 Dimensions

5.6 Abmessungen

Flangia entrata / Input flange / Antriebsflansch

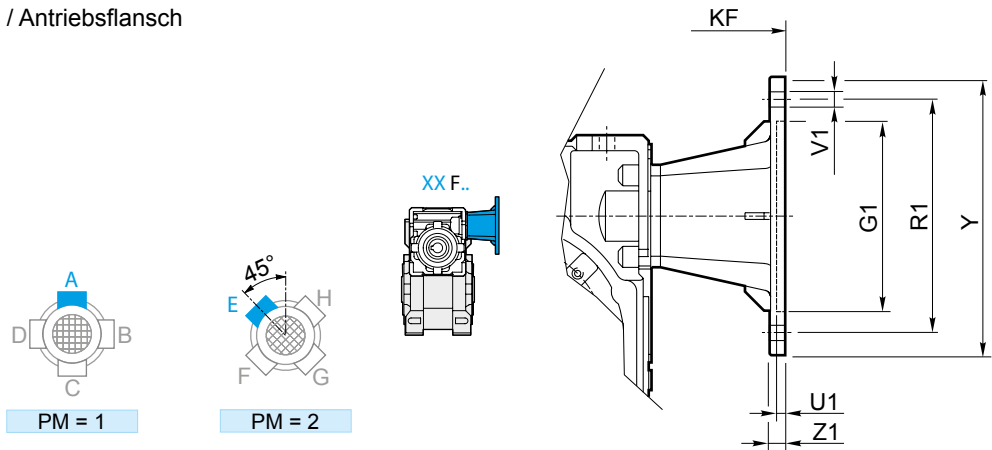

XXF	IEC	PM		G ₁	K _F	R ₁	U ₁	Ø	V ₁			Y	Z ₁
		1	2						Ø	Ø	Ø		
30/30 30/40 30/50 30/63	56 B5	•	•	80	82.5	100	3.5	7		8		120	8
	56 B14		•	50	82.5	65	3.5	6			4	80	8
	63 B5	•	•	95	85.5	115	4	9		8		140	10
	63 B14	•	•	60	85.5	75	3.5	6		8		90	8
40/63 40/75 40/90	56 B5	•	•	80	101.5	100	3.5	7		8		120	8
	63 B5	•	•	95	104.5	115	4	9		8		140	10
	63 B14	•	•	60	104.5	75	3.5	6		8		90	8
	71 B5	•	•	110	111.5	130	4.5	9		8		160	10
	71 B14	•	•	70	111.5	85	4	7		8		105	10
50/75 50/90 50/110	63 B5	•	•	95	119.5	115	4	9		8		140	10
	71 B5	•	•	110	126.5	130	4.5	9		8		160	10
	71 B14		•	70	126.5	85	3.5	7			4	105	10
	80 B5	•	•	130	136.5	165	4.5	11		8		200	10
	80 B14	•	•	80	136.5	100	4	7		8		120	10
63/110 63/130	71 B5	•	•	110	141.5	130	4.5	9		8		160	10
	80/90 B5	•	•	130	161.5	165	4.5	11		8		200	10
	80 B14	•	•	80	151.5	100	4	7		8		120	10
	90 B14	•	•	95	161.5	115	4	9		8		140	10

5.7 Limitatore di coppia cavo passante

Concepito per lavorare a bagno d'olio, il dispositivo risulta affidabile nel tempo ed è esente da usura se non viene mantenuto in condizioni prolungate di slittamento (condizione che si verifica quando la coppia presenta valori superiori a quelli di taratura).

La taratura è facilmente regolabile dall'esterno attraverso il serraggio di una ghiera autobloccante che porta a compressione le 4 molle a tazza disposte tra loro in serie.

Il dispositivo non consente:

- l'impiego di cuscinetti a rulli conici in uscita
- funzionamento prolungato in condizioni di slittamento.

Nella tabella seguente vengono riportati i valori delle coppie di slittamento M_{2S} in funzione del n° di giri della ghiera.

5.7 Torque limiter with through hollow shaft

Designed to be working in oil bath, the device is reliable over time and is not subject to wear unless in case of operation with prolonged slipping (it occurs when the torque values are higher than the calibration values).

Calibration can be easily adjusted from outside by tightening of the self-locking ring nut, which causes the compression of the 4 Belleville washers arranged in series.

The device does not go together with:

- the use of tapered roller bearings at output
- prolonged operation under slipping conditions

The following table shows the values of M_{2S} slipping torques depending on the number of revolutions of the ring nut.

5.7 Drehmomentbegrenzer mit durchgehender Hohlwelle

Er ist zuverlässig und verschleißfrei (nur im Falle eines dauerhaften Rutschens entsteht Verschleiß, hier ist das Drehmoment größer als der eingestellte Eichwert).

Die Eichung kann mühelos von aussen durch das Anziehen einer selbstsperrenden Mutter ausgeführt werden, dadurch wird der Druck auf die 4 wechselseitig angeordneten Tellerfedern erhöht.

Die Vorrichtung sieht das folgende nicht vor:

- die Verwendung von Kegelrollenlager am Abtrieb
- Längerer Rutschbetrieb

Die nachstehende Tabelle zeigt die Werte der Rutschmomente M_{2S} abhängig von der Anzahl der Umdrehungen der Mutter. Die Eichwerte weisen $\pm 10\%$ Toleranz

5.7 Limitatore di coppia cavo passante

5.7 Torque limiter with through hollow shaft

5.7 Drehmomentbegrenzer mit durchgehender Hohlwelle

XX-KX KK	N°. giri della ghiera di regolazione / N°. revolutions of ring nut / Nr. Umdrehungen der Mutter														
	1	1 1/4	1 1/2	1 3/4	2	2 1/4	2 1/2	2 3/4	3	3 1/4	3 1/2	3 3/4	4	4 1/4	4 1/2
30/30	20	25	30	35	40										
30/40	50	60	70	80	90										
30/50	75	95	115	135	155										
30/63		110	125	145	160	180	200	220	230	245	255	265	285		
40/63															
40/75			220	245	275	310	350	375	410	450					
50/75															
40/90				330	365	410	435	465	500	530	560	580	600	630	670
50/90															
50/110		750	860	1000	1100	1230									
63/110															
63/130															

I valori di taratura presentano una tolleranza del $\pm 10\%$ e si riferiscono ad una condizione statica.

In condizioni dinamiche è da notare che la coppia di slittamento assume valori diversi a seconda del tipo e/o modalità in cui si verifica il sovraccarico: con valori maggiori in caso di carico uniformemente crescente rispetto a valori più contenuti in seguito al verificarsi di picchi improvvisi di carico.

NOTA: quando si supera il valore di taratura si ha slittamento. Il coefficiente di attrito tra le superfici di contatto da statico diventa dinamico e la coppia trasmessa cala del 30% circa.

E' quindi opportuno prevedere uno stop per poter ripartire al valore di taratura iniziale.

Calibration values feature a $\pm 10\%$ tolerance and refer to static conditions.

Under dynamic conditions the values of the slipping torque will change according to the type of overload: the values are higher if the load increase is uniform; the values are lower if sudden load peaks occur.

NOTE: Slipping occurs when the setting values are exceeded.

The friction coefficient between the contact surfaces from static becomes dynamic and the transmitted torque is approx. 30% lower.

It is advisable to have a stop first in order to have a restart based on the initial setting value.

auf und beziehen sich auf statische Bedingungen.

Unter dynamischen Bedingungen hat das Rutschmoment verschiedene Werte je nach Art der Überbelastung. Die Werte sind höher, wenn die Belastung gleichmäßig zunimmt; sie sind niedriger im Falle von plötzlichen Belastungsspitzen.

BEMERKUNG: Rutschen tritt auf, wenn die eingestellten Werte überschritten werden. Der Reibungsfaktor zwischen den Berührungsflächen wird dynamisch anstatt statisch und das übertragene Drehmoment sinkt um ca. 30%.

Es ist daher ratsam, vor dem erneuten Anfahren anzuhalten, um die ursprünglichen Drehmomentwerte zu erreichen.

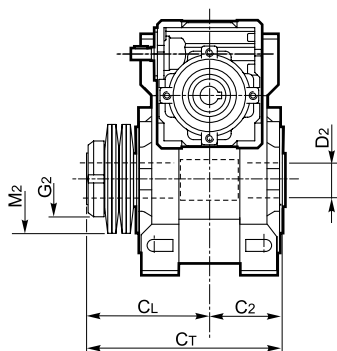

Disposizione delle molle
Washers' arrangement
Lage der Feder

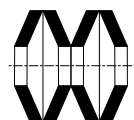

IN SERIE (min. coppia, max. sensibilità)
SERIES (min. torque, max sensitivity)
SERIE (min. Moment, max. Empfindlichkeit)

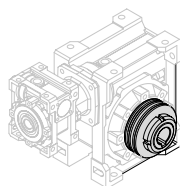

LD

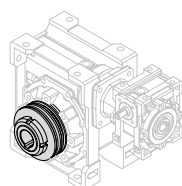

LS

XX - KX LD - LS	C ₂	C _L	C _t	D ₂ H ₈	G ₂	M ₂
30/30	31.5	55.5	87	14	M25x1.5	50x25.4x1.5
30/40	39	65	104	18 (19)	M30x1.5	56x30.5x2
30/50	46	76	122	25 (24)	M40x1.5	63x40.5x2.5
30/63 40/63	56	91	147	25	M40x1.5	71x40.5x2.5
40/75 50/75	60	100	160	28 (30)	M50x1.5	90x50.5x3.5
40/90 50/90	70	109	179	35 (32)	M50x1.5	100x51x3.5
50/110 63/110	77.5	127.5	205	42	M60x2	125x61x5
63/130						

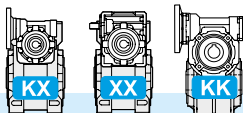

5.8 Esecuzione con vite bisporgente

5.8 Double extended worm shaft design

5.8 Versionen mit Doppelseitig Herausragender Schneckenwelle

SeA1

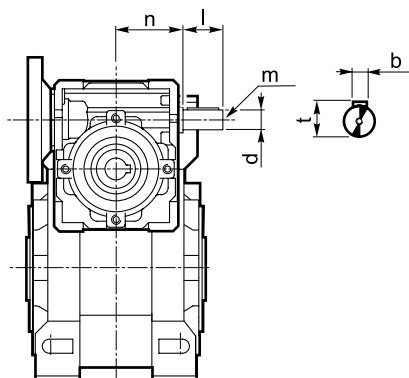

SeA2

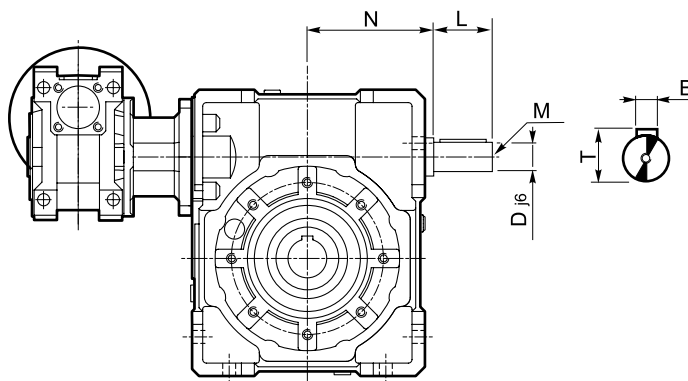

L'entrata supplementare del riduttore in uscita (SeA2) non può essere utilizzata come comando in quanto il relativo movimento risulta impedito dalla irreversibilità del primo riduttore. Utilizzato come asse condotto, avrà velocità corrispondente a quella di ingresso ridotta del rapporto del primo riduttore.

The second input shaft of the output gearbox (SeA2) can not be utilized as a drive because its motion will be stopped by the reversibility of the first gearbox. If utilized as a drive shaft its speed will be equal to the input speed decreased by the ratio of the first gearbox.

Die verlängerte Schneckenwelle des zweiten Getriebes (SeA2) kann nicht als Antrieb verwendet werden, da die Selbsthemmung des ersten Getriebes entgegengewirkt. Wird sie als Abtriebswelle verwendet, besitzt sie eine um die Untersetzung des ersten Getriebes entsprechend reduzierte Drehzahl und Drehmoment.

KXC - XXC XXF - XXA KKC	SeA1							SeA2						
	b	d j6	l	m	n		t	B	D j6	L	M	N		T
					KK-KX	XX						KK	KX-XX	
30/30	3	9	15	M4x10	42.5	42.5	10.2	3	9	15	M4x10	42.5	42.5	10.2
30/40	3	9	15	M4x10	42.5	42.5	10.2	4	11	20	M4x12	52.5	52.5	12.5
30/50	3	9	15	M4x10	42.5	42.5	10.2	5	14	25	M5x13	62.5	62.5	16
30/63	3	9	15	M4x10	42.5	42.5	10.2	6	19	30	M8x20	72.5	74.5	21.5
40/63	4	11	20	M4x12	52.5	52.5	12.5	6	19	30	M8x20	72.5	74.5	21.5
40/75	4	11	20	M4x12	52.5	52.5	12.5	8	24	40	M8x20	89	91	27
50/75	5	14	25	M5x13	62.5	62.5	16	8	24	40	M8x20	89	91	27
40/90	4	11	20	M4x12	52.5	52.5	12.5	8	24	40	M8x20	108	108	27
50/90	5	14	25	M5x13	62.5	62.5	16	8	24	40	M8x20	108	108	27
50/110	5	14	25	M5x13	62.5	62.5	16	8	28	50	M8x20	132	132	31
63/110	6	19	30	M8x20	72.5	74.5	21.5	8	28	50	M8x20	132	132	31
63/130	6	19	30	M8x20	72.5	74.5	21.5	10	38	70	M10x25	152	152	41

5.9 Accessori

5.9 Accessories

5.9 Accessories

Albero lento

Albero lento semplice
Single output shaft
Standard Abtriebswelle

Output shaft

Abtriebswelle

Albero lento doppio
Double output shaft
Doppelte Abtriebswelle

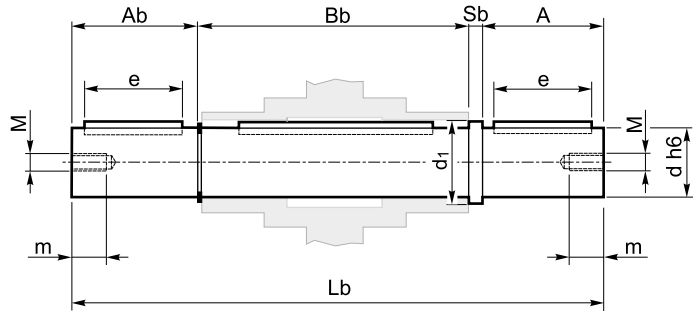
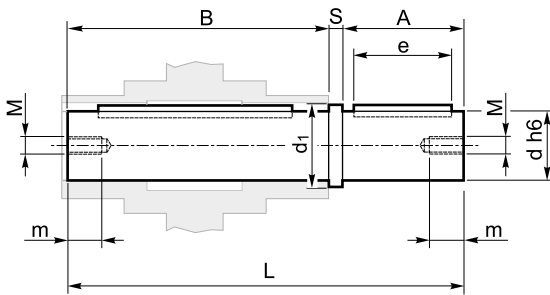

KK-KX-XX	A	B	d _{h6}		d ₁	e	L	M	m	S	A	A _b	B _b	d _{h6}	d ₁	e	L _b	S _b
30/30	30	62	14		18.5	20	94.5	M6	16	2.5	30	29	64	14	18.5	20	126	2.5
30/40	40	77	18	19	23.5	30	120	M6	16	3	40	39	79	18	23.5	30	161	3
30/50	50	90	25	24	31.5	40	143.5	M8	22	3.5	50	49	93	25	31.5	40	195.5	3.5
30/63 40/63	50	111	25		31.5	40	165	M8	22	4	50	49	113	25	31.5	40	216	4
40/75 50/75	60	119	28	30	34.5	50	183	M8	22	4	60	59	121	28	34.5	50	244	4
40/90 50/90	80	139	35		41.5	60	224	M10	28	5	80	78.5	141.5	35	41.5	60	305	5
50/110 63/110	80	154.5	42		49.5	60	242.5	M10	28	8	80	77.5	157	42	49.5	60	322.5	8
63/130	80	168	45		54.5	70	253	M16	36	5	80	78	172	45	54.5	70	335	5

Braccio di reazione

Torque arm

Drehmomentstütze

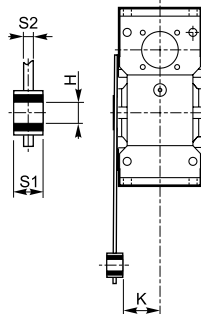
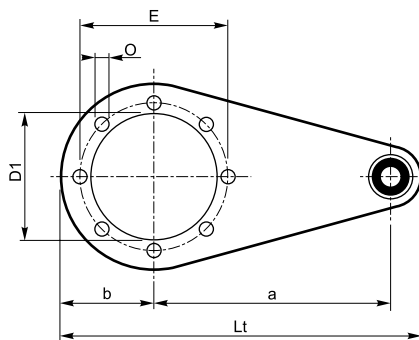

KK KX XX	a	b	D ₁	E	H	K	L _t	O	S1	S2
30/30	85	37.5	55	65	8	24	141.5	7	14	4
30/40	100	45	60	75	10	31.5	167	7	14	4
30/50	100	50	70	85	10	39	172	9	14	5
30/63 40/63	150	55	80	95	10	49	227	9	14	6
40/75 50/75	200	70	95	115	20	47.5	302	9	25	6
40/90 50/90	200	80	110	130	20	57.5	312	11	25	6
50/110 63/110	250	100	130	165	25	62	390	11	30	6
63/130	250	125	180	215	25	69	415	13	30	6

Kit di protezione: solo su versione P

Protection Kit: only for P version

Schutzvorrichtung: nur für Version P

Albero cavo / Hollow shaft / Hohlwelle

Limitatore di coppia / Torque limiter / Drehmomentbegrenzer

KK KX XX	A		B		C	
	IN	OUT	IN	OUT	IN	OUT
30/30		12		13		39
30/40	12	14	13	15.5	39	44
30/50		15		16.5		54
30/63 40/63		17		19		60
40/75 50/75	14	15.5		20	44	70
40/90 50/90	15	16.5	20	54		
40/90 50/90	14	15.5	24	44		80
50/90	15	16.5		54		
50/110	15	21.5		54		
50/110	15	16.5		54		
63/110	17	22	25	60		96
63/110	17	22	19	25	60	130
63/130	17	22	19	25	60	130

KK KX XX	A		B		C	
	IN	OUT	IN	OUT	IN	OUT
30/30		36		37		36
30/40		40		41.5		44
30/50	36	47	37	48.5	36	53
30/63 40/63		52		54		55
40/75 50/75	40	52		54		55
40/75 50/75	40	52	41.5	54	44	55
50/75	47	58	48.5	60	53	68
40/90 50/90	40	60.5	41.5	63	44	70
50/90	47	60.5	48.5	63	53	70
50/110	47	72	48.5	75	53	85
63/110	52	72	54	75	55	85
63/130	52	72	54	75	55	85

Opzioni disponibili:

Available options:

Auf Anfrage ist folgendes Zubehör erhältlich:

Cuscinetti a rulli conici corona

Tapered roller bearing on wormgear

Kegelrollenlager auf Schneckenrad

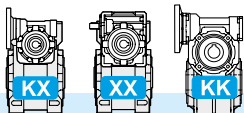

5.10 Lista parti di ricambio

5.10 Spare parts list

5.10 Ersatzteilliste

KXC - XXC - XXA - XXF - KKC

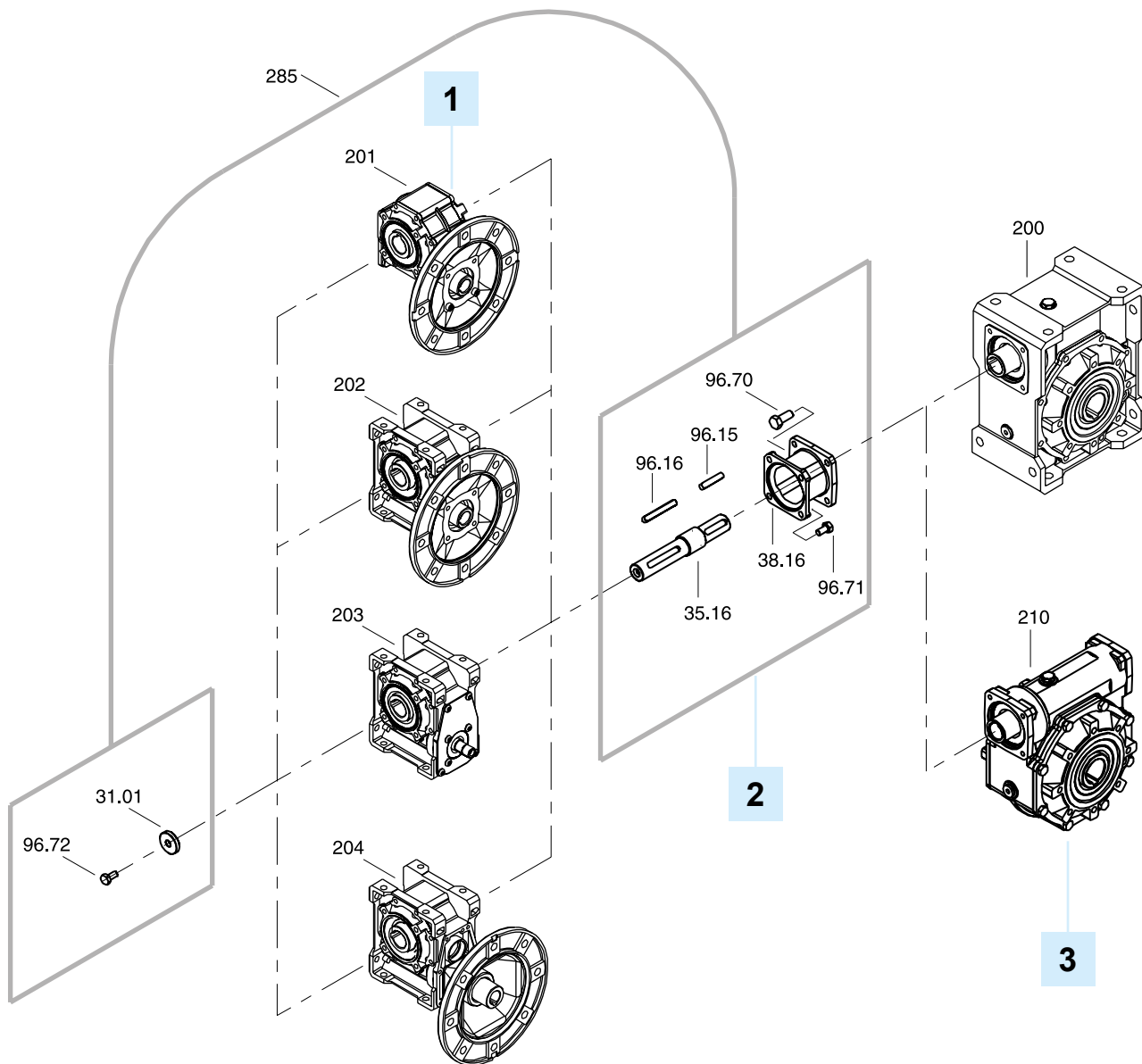

1

2

3

	IN X..P - K..P	KIT	OUT XC - KC
30/30	X30 KC30	KIT 30/30 (2850002010)	30/9
30/40		KIT 30/40 (2850002013)	40/11
30/50		KIT 30/50 (2850002016)	50/14
30/63		KIT 30/63 (2850002019)	63/19
40/63	X40 KC40	KIT 40/63 (2850002028)	63/19
40/75		KIT 40/75-90 (2850002031)	75/24
40/90			90/24
50/75	X50 KC50	KIT 50/75-90 (2850002034)	75/24
50/90		KIT 50/110 (2850002049)	90/24
50/110			110/28
63/110	X63 KC63	KIT 63/110-130 (2850002052)	110/28
63/130	X63 KC63	KIT 63/110-130 (2850002052)	110/28

X - H - K - KX - XX - KK

Limitatore di coppia cavo passante

Torque limiter with through hollow shaft

Drehmomentbegrenzer mit durchgehende Hohlwelle

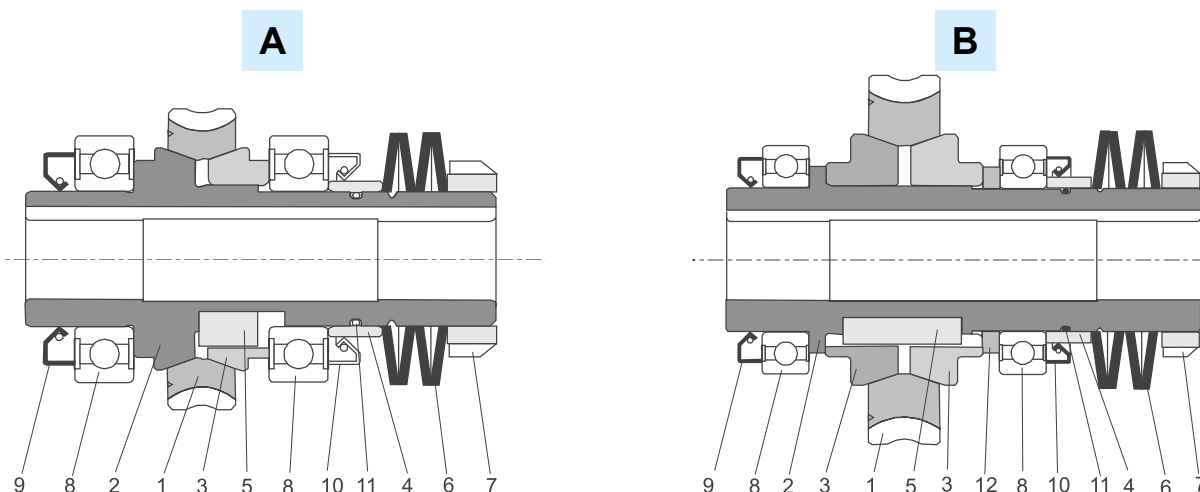

A			B				
X - H - K							
30 (LD - LS)	40 (LD - LS)	50 (LD - LS)	63 (LD - LS)	75 (LD - LS)	90 (LD - LS)	110 (LD - LS)	130 (LD - LS)
KX - XX - KK							
30/30 (L1-LD-LS) 30/40 (L1) 30/50 (L1) 30/63 (L1)	30/40 (LD - LS) 40/63 (L1) 40/75 (L1) 40/90 (L1)	30/50 (LD - LS) 50/75 (L1) 50/90 (L1) 50/110 (L1)	30/63 (LD - LS) 40/63 (LD - LS) 63/110 (L1)	40/75 (LD - LS) 50/75 (LD - LS)	40/90 (LD - LS) 50/90 (LD - LS)	50/110 (LD - LS) 63/110 (LD - LS)	63/130 (LD - LS)
1 Corona in bronzo / Bronze wheel / Bronzerad /							
2 Albero cavo limitatore / Hollow shaft torque limiter / Rutschkupplungs-Hohlwelle							
3 Anello di frizione / Friction ring / Reibring							
4 Distanziale molle / Washers' distance ring / Federdistanzring							
5 Linguetta / key / Passfeder							
8x7x10AB	10x8x13AB	12x8x18AB	12x8x40A	16x10x40A	16x10x50A	18x11x60A	
6 Molle a tazza / Belleville washers / Tellerfeder							
7 Ghiera / Metal ring / Metall Ring							
6005 25x47x12	6006 30x55x13	6008 40x68x15	6008 40x68x15	6010 50x80x16	6010 50x80x16	6012 60x95x18	
25x40x7	30x47x7	40x62x8	40x62x8	50x72x8	50x72x8	60x85x8	
30x40x5	35x47x7	48x62x8	48x62x8	58x72x8	58x72x8	70x85x8	
OR2087 21.95x1.78	OR2106 26.7x1.78	OR 36.27x1.78	OR 36.27x1.78	OR2187 47.37x1.78	OR2187 47.37x1.78	OR2225 56.87x1.78	
12 —			Distanziale / Spacer / Abstandshülse				

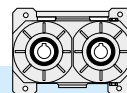

6.0	RIDUTTORI A VITE SENZA FINE CON DOPPIA USCITA	DOUBLE OUTPUT WORM GEARBOXES	SCHNECKENGETRIEBE MIT ZWEI AUSGANGSWELLEN
6.1	Caratteristiche	<i>Characteristics</i>	Merkmale 112
6.2	Designazione	<i>Designation</i>	Bezeichnung 112
6.3	Dati tecnici	<i>Technical data</i>	Technische Daten 113
6.4	Lubrificazione	<i>Lubrication</i>	Schmierung 114
6.5	Carichi radiali e assiali	<i>Radial and axial loads</i>	Radial und axial Belastungen 114
6.6	Dimensioni	<i>Dimensions</i>	Abmessungen 115

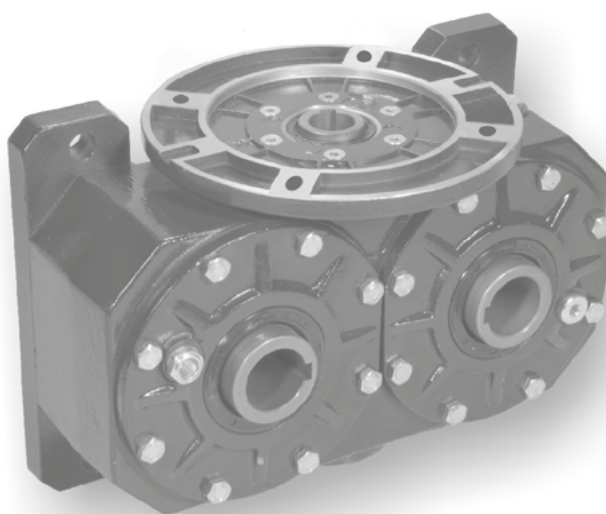

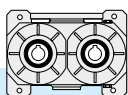

La serie di vite senza fine con doppia uscita comprende riduttori costruiti appositamente per soddisfare delle specifiche esigenze di automazione.

Il cinematismo, composto da una vite senza fine e due corone, consente di disporre, all'uscita, di due alberi cavi con una rotazione sincrona controrotante.

La motorizzazione può essere effettuata tramite motori elettrici o motorvariatori provvisti di una flangia di fissaggio dimensionata a norme IEC.

Double output worm gearboxes series includes gearboxes specially manufactured to comply with specific requirements.

The kinematic motion is carried out by means of a wormshaft and two wormwheels in order to have two output shafts with a synchronous rotation.

These gearboxes can be assembled to electric motors or moto variators fully comply with the IEC specifications.

Bei der Schneckengetriebe mit Zwei Ausgangswellen Serie handelt es sich um Schneckengetriebe, die für spezielle Antriebsaufgaben eingesetzt werden.

Der Aufbau besteht aus einer Schnecke und zwei Schneckenräder umgewandelt. Der Antrieb erfolgt durch IEC Normmotoren oder Verstellgetriebemotoren.

6.1 Caratteristiche

- **Corpo e flange**
Costruiti in alluminio e verniciati colore BLU RAL 5010
- **Vite senza fine**
In acciaio legato. Indurita tramite cementazione e tempra e finita di rettifica
- **Corona**
Fascia dentata in bronzo GcuSn12 UNI 7013 riportata di fusione su mozzo in ghisa G20 UNI 5007
- **Cuscinetti**
Sulla vite e sulle due uscite sono montati cuscinetti a rulli conici
- **Lubrificazione**
Normalmente i riduttori vengono forniti privi di lubrificante. Su richiesta possono essere forniti con lubrificante sintetico

6.1 Characteristics

- **Casing and flanges**
Made from aluminium and painted BLUE RAL 5010
- **Worm screw**
Made from alloy steel. Hardened and case-hardened then finished by grinding
- **Worm wheel**
UNI 7013 GcuSn12 bronze toothed band. Inserted by casting on UNI 5007 G20 cast-iron hub.
- **Bearings**
Taper roller bearings are mounted on the screw and on the two outputs
- **Lubrication**
Gearboxes are normally supplied without lubricant. However, they can be supplied with synthetic lubricant on request

6.1 Merkmale

- **Gehäuse und Flansche**
Aus Aluminium gefertigt und mit Farbe BLAU RAL 5010 lackiert
- **Schnecke**
Aus legiertem Stahl. Gehärtet durch Einsatzhärtung und Abschreckhärtung mit Fertigschliff
- **Zahnkranz**
Zahnband aus Bronze GcuSn 12 UNI 7013, aufgegossen auf Nabe aus Guss-eisen G20 UNI 5007
- **Lager**
Auf der Schnecke und auf den beiden Abtrieben werden Kegelrollenlager montiert.
- **Schmierung**
Normalerweise werden die Getriebe ohne Schmiermittel geliefert. Auf Anfrage können sie mit synthetischem Schmiermittel geliefert werden

6.2 Designazione

6.2 Designation

6.2 Bezeichnung

Riduttore Gearbox Getriebe	Tipo entrata Input type Antriebsart	Grandezza Size Größe	Rapporto rid. Ratio Untersetzung	Predispos.att. mot. Motor coupling Motoranschluss
VSF.2USC.	VM	135	40	pam 200/19
	VM VI	135 150 170 230	i	

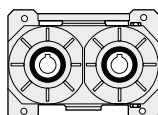

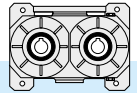

6.3 Dati tecnici

6.3 Technical data

6.3 Technische Daten

Tipo Size Typ			135	150		170		230			
				13	15.5		19		40		
		i	40	7.5	40	40	80	10	28	40	
VM	$n_1 = 1400 \text{ min}^{-1}$	$n_2 \text{ [min}^{-1}\text{]}$	35	187	35	35	17.5	140	50	35	
		$P_1 \text{ [kW]}$	0.75	1.8	0.75	1.8	1.5	4	4	1.8	
		$T_2 \text{ [Nm]}$	66	37	65	160	221	109	268	160	
		F_s	2	3.7	2.6	1.4	1	3.8	1.6	2.8	
VI	$n_1 = 1400 \text{ min}^{-1}$	$n_2 \text{ [min}^{-1}\text{]}$	35	/	/	35	17.5	/	/	/	
		$P_1 \text{ [kW]}$	1.5	/	/	2.6	1.5	/	/	/	
		$T_2 \text{ [Nm]}$	131	/	/	234	218	/	/	/	
		η_D	0.64	/	/	0.65	0.54	/	/	/	
	$n_1 = 900 \text{ min}^{-1}$	$n_2 \text{ [min}^{-1}\text{]}$	23	/	/	23	11	/	/	/	
		$P_1 \text{ [kW]}$	1.2	/	/	2	1.1	/	/	/	
		$T_2 \text{ [Nm]}$	158	/	/	269	247	/	/	/	
		η_D	0.60	/	/	0.62	0.51	/	/	/	
	$n_1 = 500 \text{ min}^{-1}$	$n_2 \text{ [min}^{-1}\text{]}$	12.5	/	/	12.5	6	/	/	/	
		$P_1 \text{ [kW]}$	0.8	/	/	1.4	0.8	/	/	/	
		$T_2 \text{ [Nm]}$	186	/	/	317	288	/	/	/	
		η_D	0.56	/	/	0.57	0.46	/	/	/	
			η_s	0.43	0.70	0.44	0.45	0.33	0.69	0.49	0.42

La coppia T_2 è riferita a ciascuna uscita. T_2 torque refers to each output

T_2 bezieht sich auf jedes Abtrieb

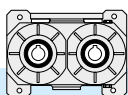

6.4 Lubrificazione

Normalmente i riduttori vengono forniti privi di lubrificante. I tappi sono predisposti come da disegno.

6.4 Lubrication

The gearboxes are normally supplied without lubricant. The filler plugs are arranged as shown in the drawing.

6.4 Schmierung

Normalerweise werden die Getriebe ohne Schmiermittel geliefert. Die Anbringung der Füllstopfen entspricht der Zeichnung.

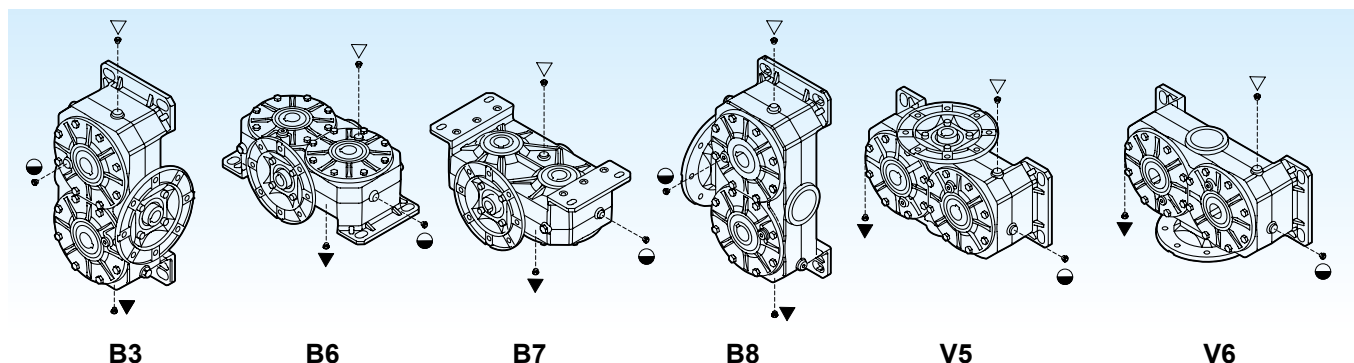

- ▽ Carico e sfiato / Filling and breather
Einfüll und Entlüftung
- Livello / Level / Ölstand
- ▼ Scarico / Drain / Ablass

		Q.tà olio / Oil quantity / Schmiermittelmenge [lt]				
		Posizione di montaggio / Mounting position / Einbaulage				
		B3	B6	B7	B8	V5 - V6
VM	135	0.8	0.6	0.6	0.8	0.5
	150	1.5	1.2	1.2	1.5	1
	170	2	1.5	1.5	2	1.2
	230	5	4.5	3.5	5	3.2

6.5 Carichi radiali e assiali

Nella tabella sono indicati i valori, espressi in N, dei carichi radiali e assiali ammissibili su ogni singola uscita. Il carico radiale F_{r2} si considera applicato ad una distanza dalla battuta dell'albero cavo pari al valore del diametro. I valori indicati hanno come limite la struttura del riduttore, perciò non variano al diminuire della velocità, cosa che normalmente avviene quando il limite è riferito ai cuscinetti.

6.5 Radial and axial loads

In the table, the permissible radial and axial loads for each individual output are shown as N. The radial load F_{r2} should be considered as applied at a distance from the shaft shoulder equal to the diameter figure. The listed values are limited by the gear drive structure, therefore, they will not change as the speed decreases, which is normally the case when bearings are the limit reference.

6.5 Radial und Axial Belastungen

In der Tabelle werden die Werte der auf jedem einzelnen Abtrieb zulässigen Radial- und Axialbelastungen in N angegeben. Hinsichtlich der radialen Belastung F_{r2} wird von einem Abstand vom Anschlag der Hohlwelle ausgegangen, der dem Wert des Durchmessers entspricht. Die angegebenen Werte werden durch die Struktur des Getriebes beschränkt und verändern sich daher bei Reduzierung der Drehzahl nicht. Dies ist normalerweise dann der Fall, wenn der Grenzwert sich auf die Lager bezieht.

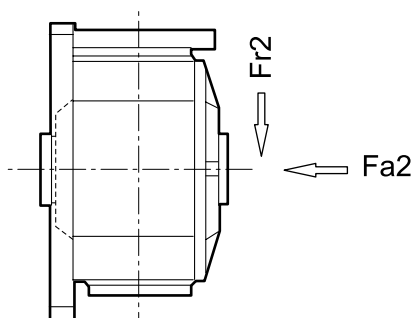

Tipo Size Typ	135	150	170	230
F_{r2} [N]	1200	1900	1700	3000
F_{a2} [N]	600	950	850	1500

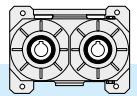

6.6 Dimensioni

6.6 Dimensions

6.6 Abmessungen

135

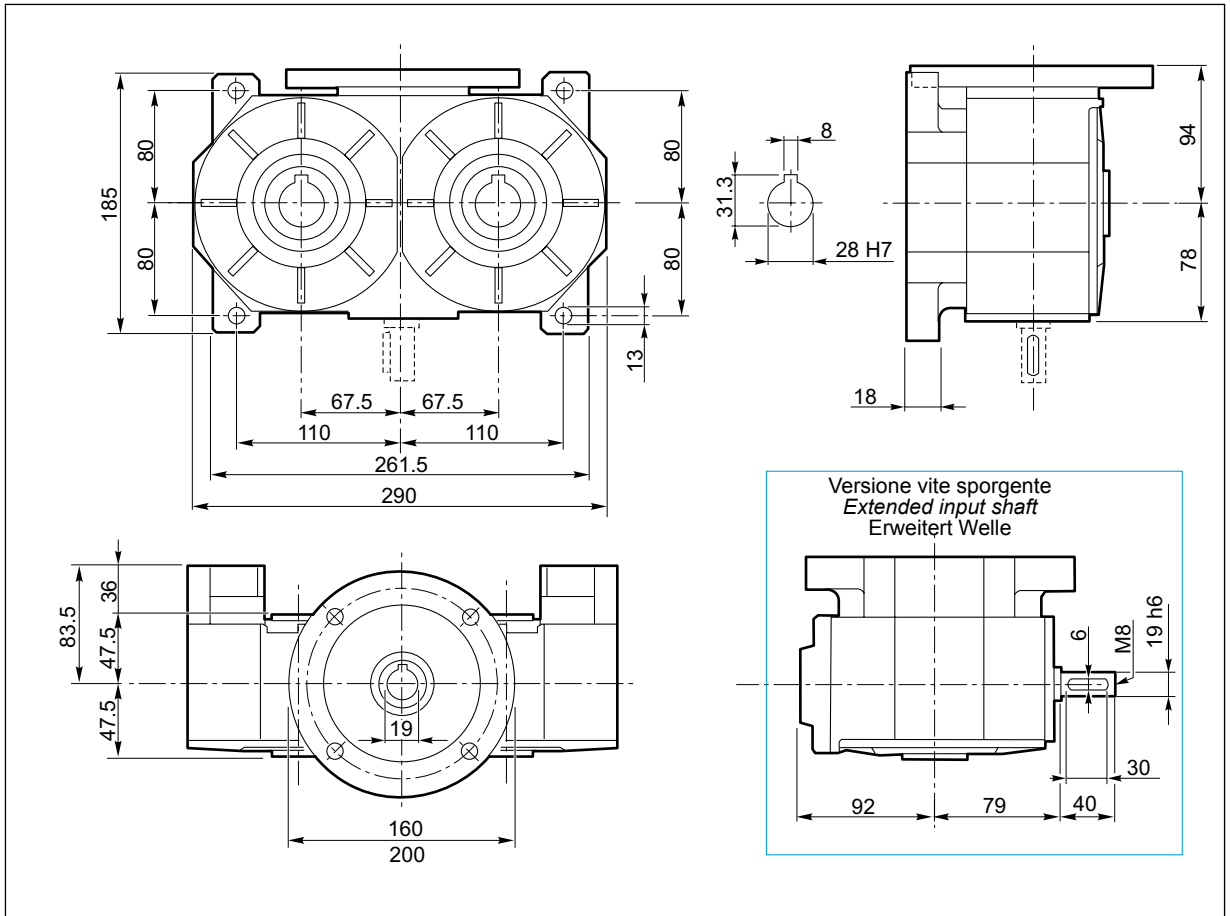

150

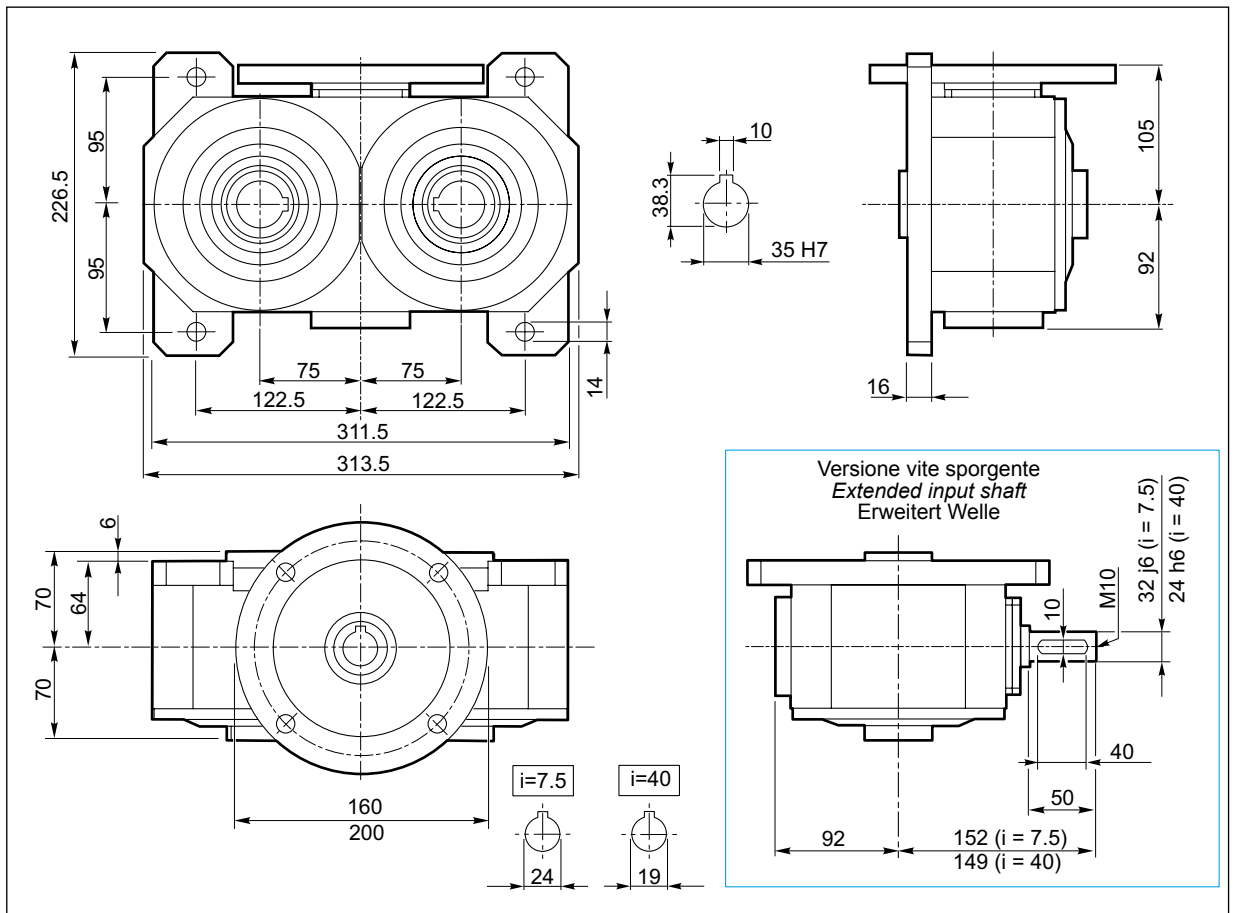

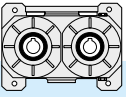

6.6 Dimensioni

6.6 Dimensions

6.6 Abmessungen

170

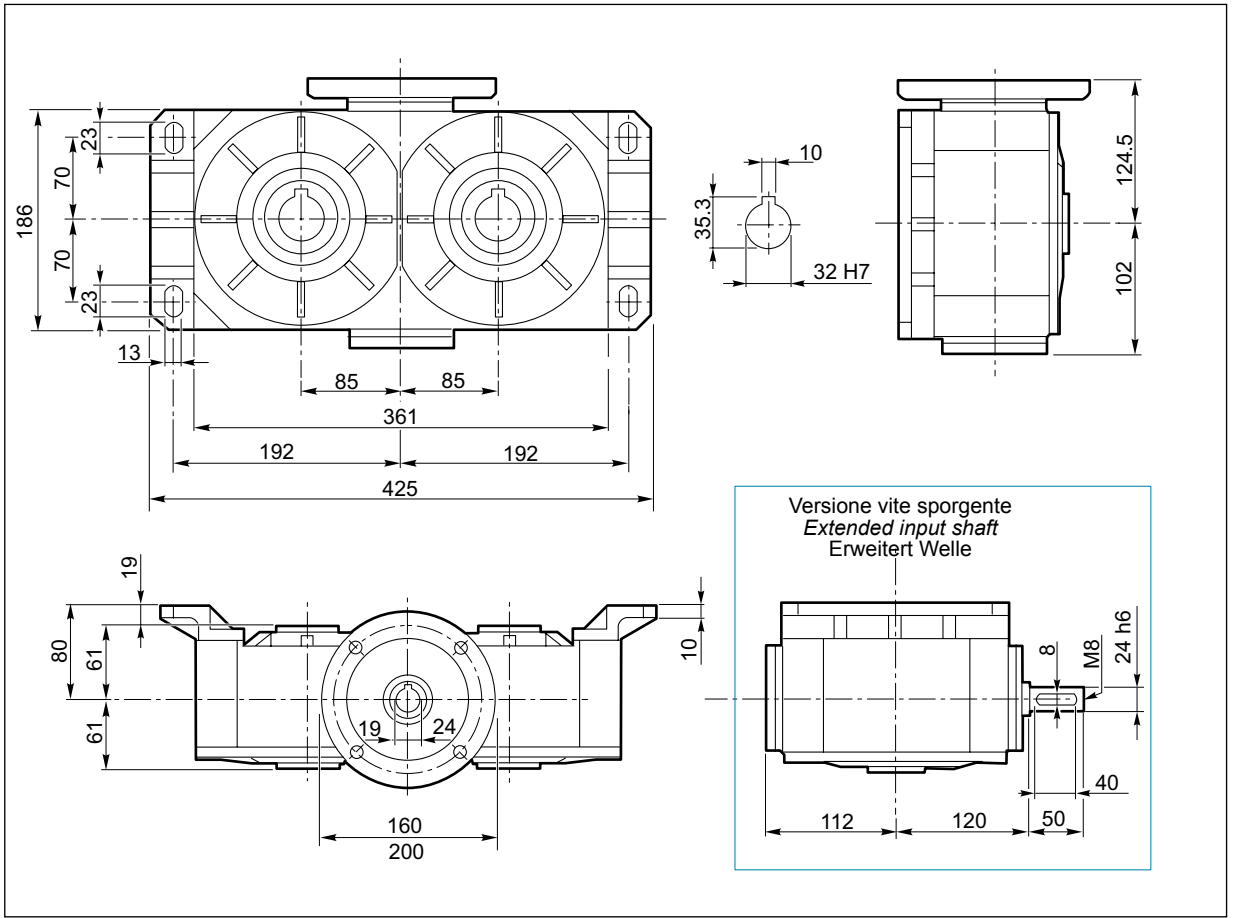

230

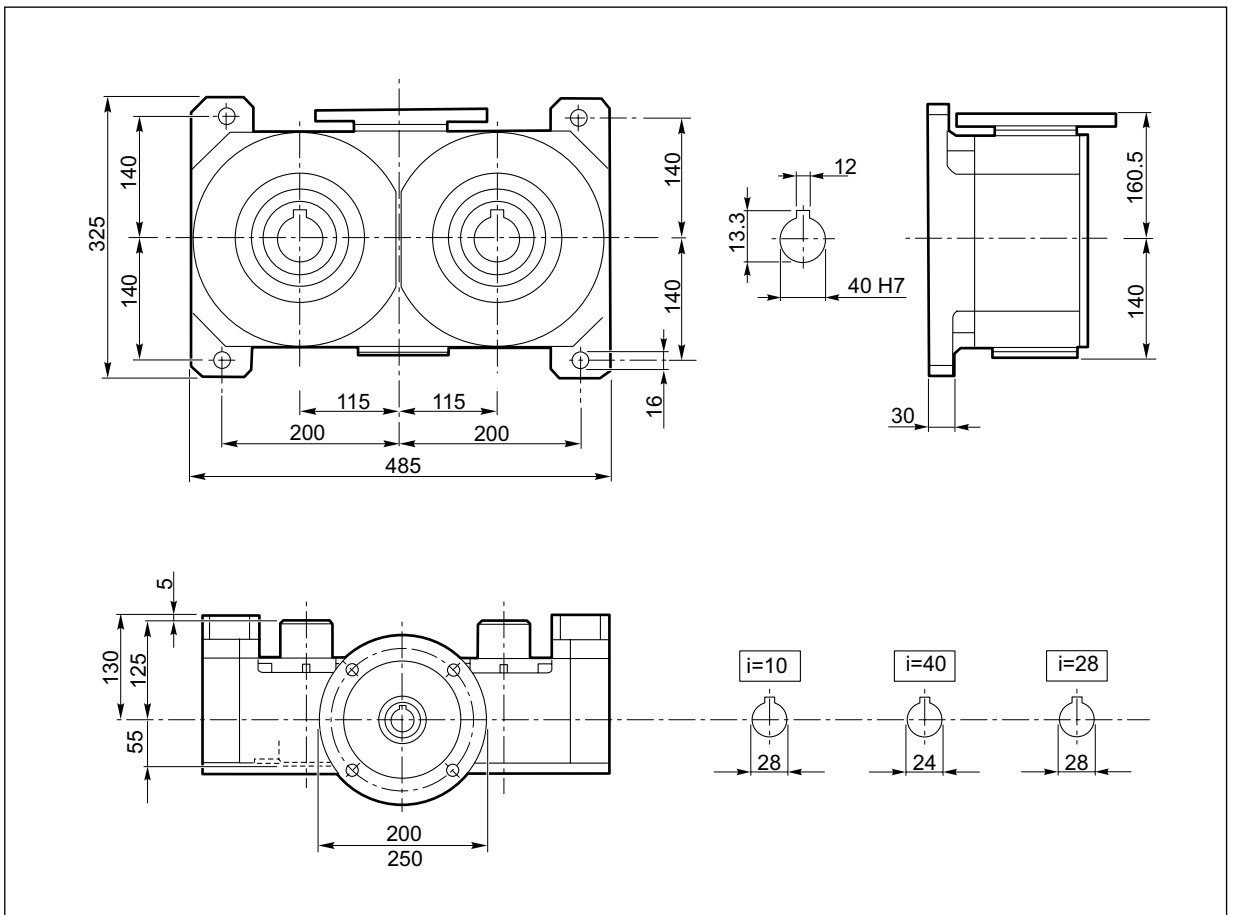

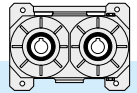

VM - VI 135

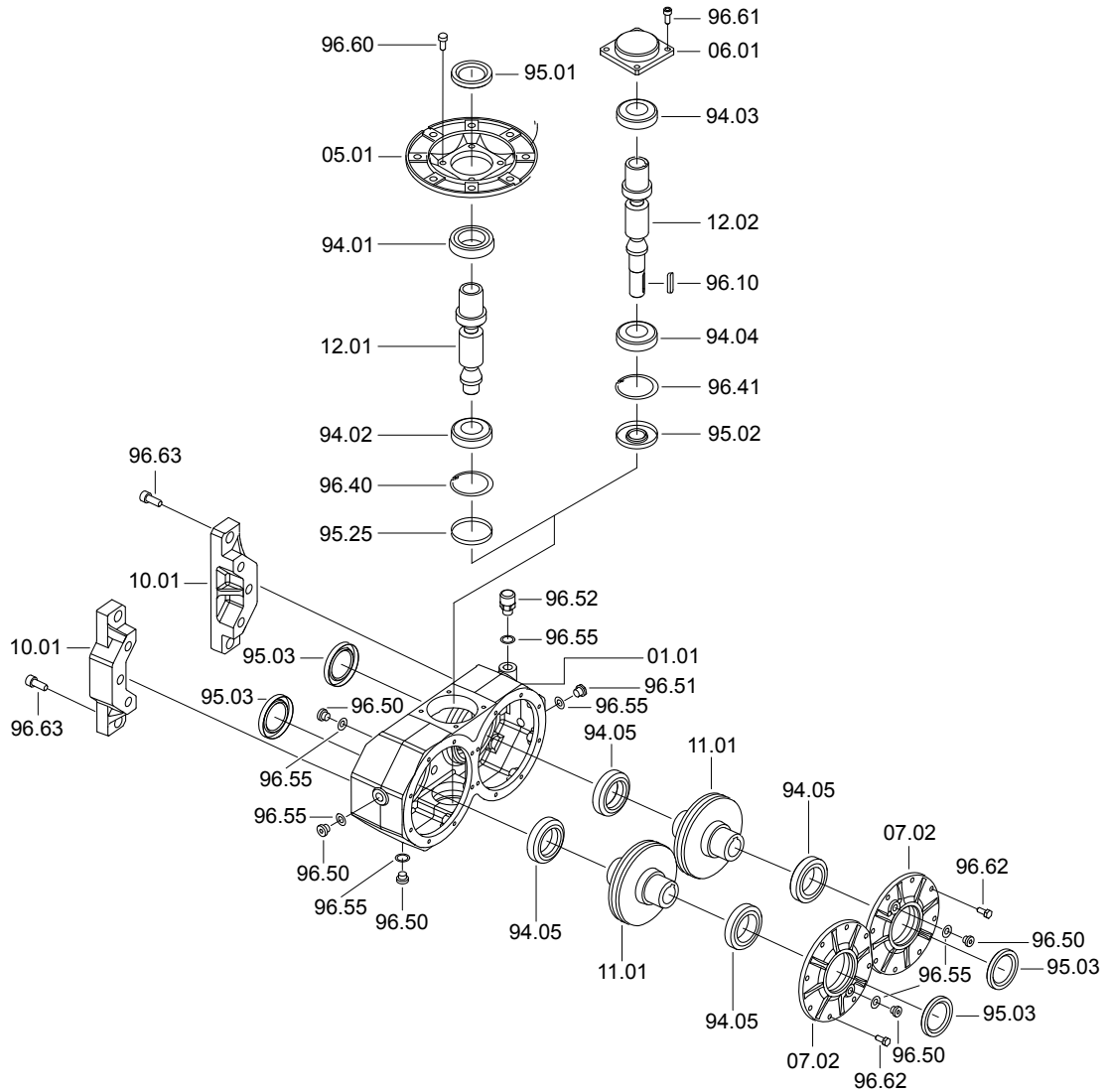

VM VI 135	Cuscinetti / Bearings / Lager					Anelli di tenuta / Oilseals Öldichtungen			Cappellotto / Closed oil seal/ Geschlossene Öldichtung
	94.01	94.02	94.03	94.04	94.05	95.01	95.02	95.03	95.25
	30206 30x62x17.25	30304 20x52x16.25	32010 50x80x20	30206 30x62x17.25	32009 45x75x20	30/56/10	20/52/10	45/65/10	ø 52x7

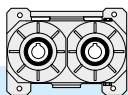

VM - VI 150

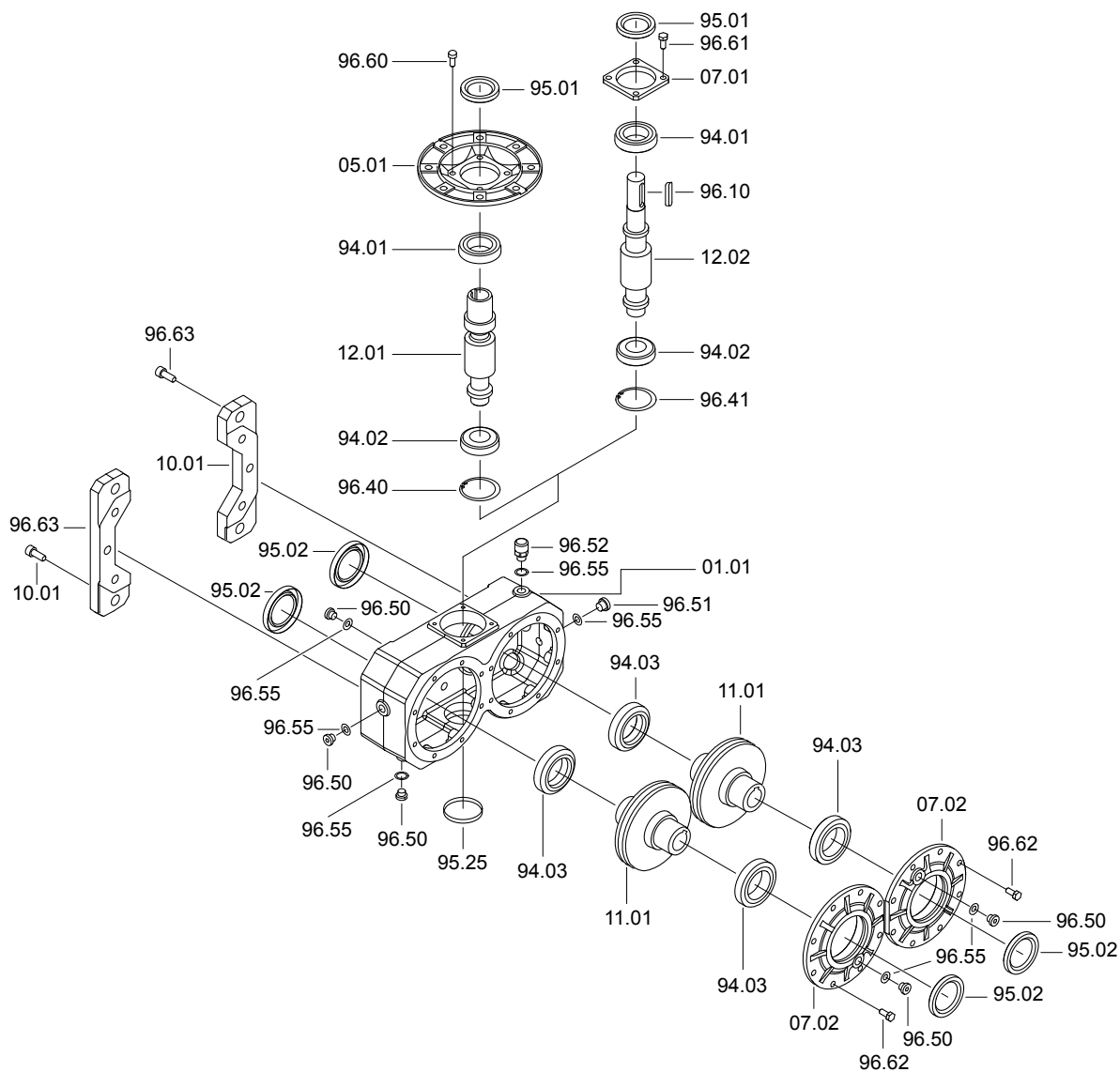

VM VI	Cuscinetti / Bearings / Lager			Anelli di tenuta / Oilseals Öldichtungen		Cappellotto / Closed oil seal Geschlossene Öldichtung
	94.01	94.02	94.03	95.01	95.02	95.25
150	32007 35x62x18	30205 25x52x16.25	32010 50x80x20	35/56/10	50/72/8	ø 52x7
	* 30305 55x62x18					

* Solo per VI150 i40 / Only for VI150 i40 / Nur für VI150 i40

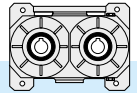

VM - VI 170

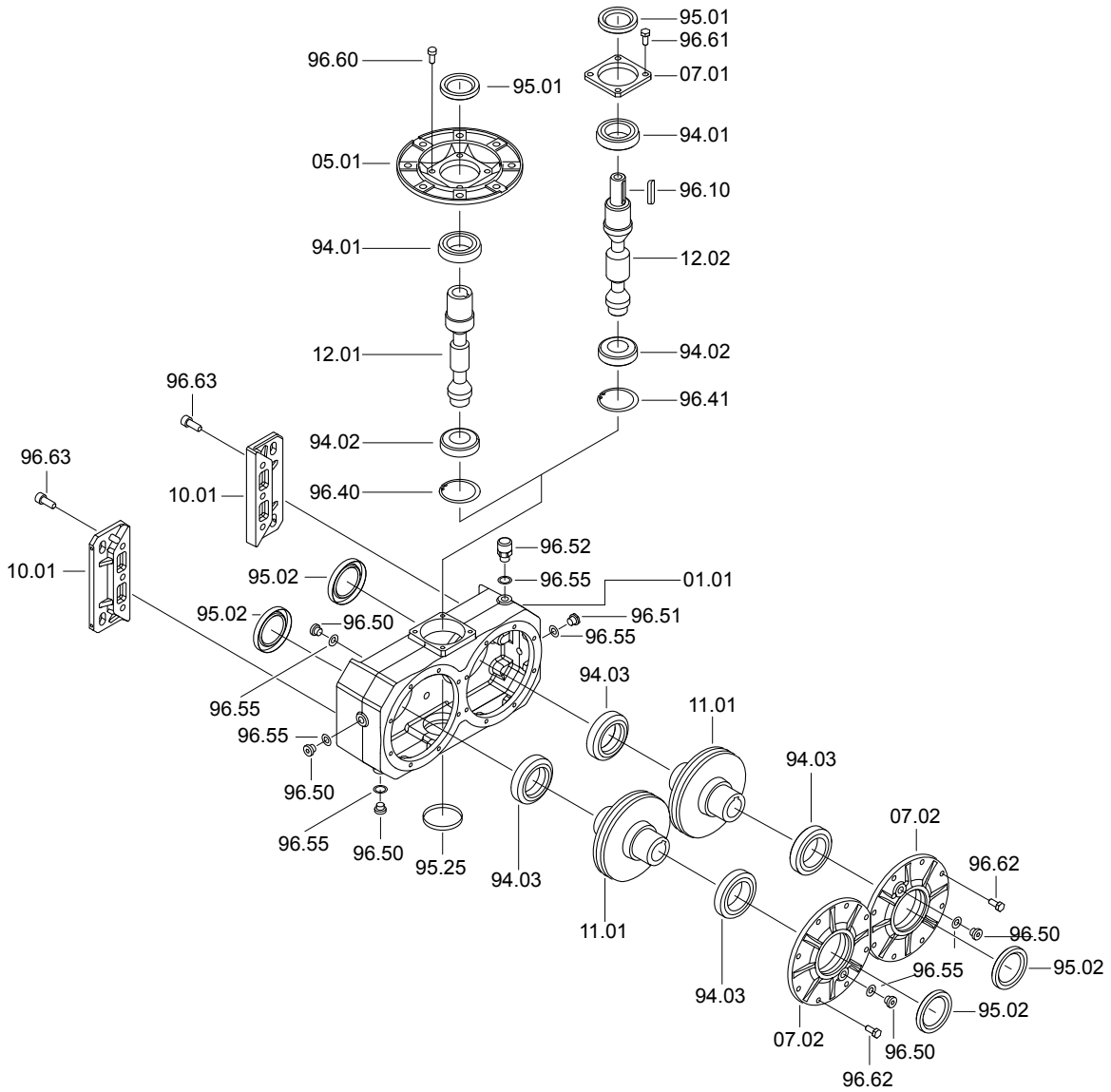

VM VI 170	Cuscinetti / Bearings / Lager			Anelli di tenuta / Oilseals Öldichtungen		Cappellotto / Closed oil seal Geschlossene Öldichtung
	94.01	94.02	94.03	95.01	95.02	95.25
	32008 40x68x19	30206 30x62x17.25	32010 50x80x20	40/62/8	50/72/8	ø 62x7

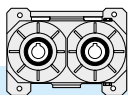

VM 230

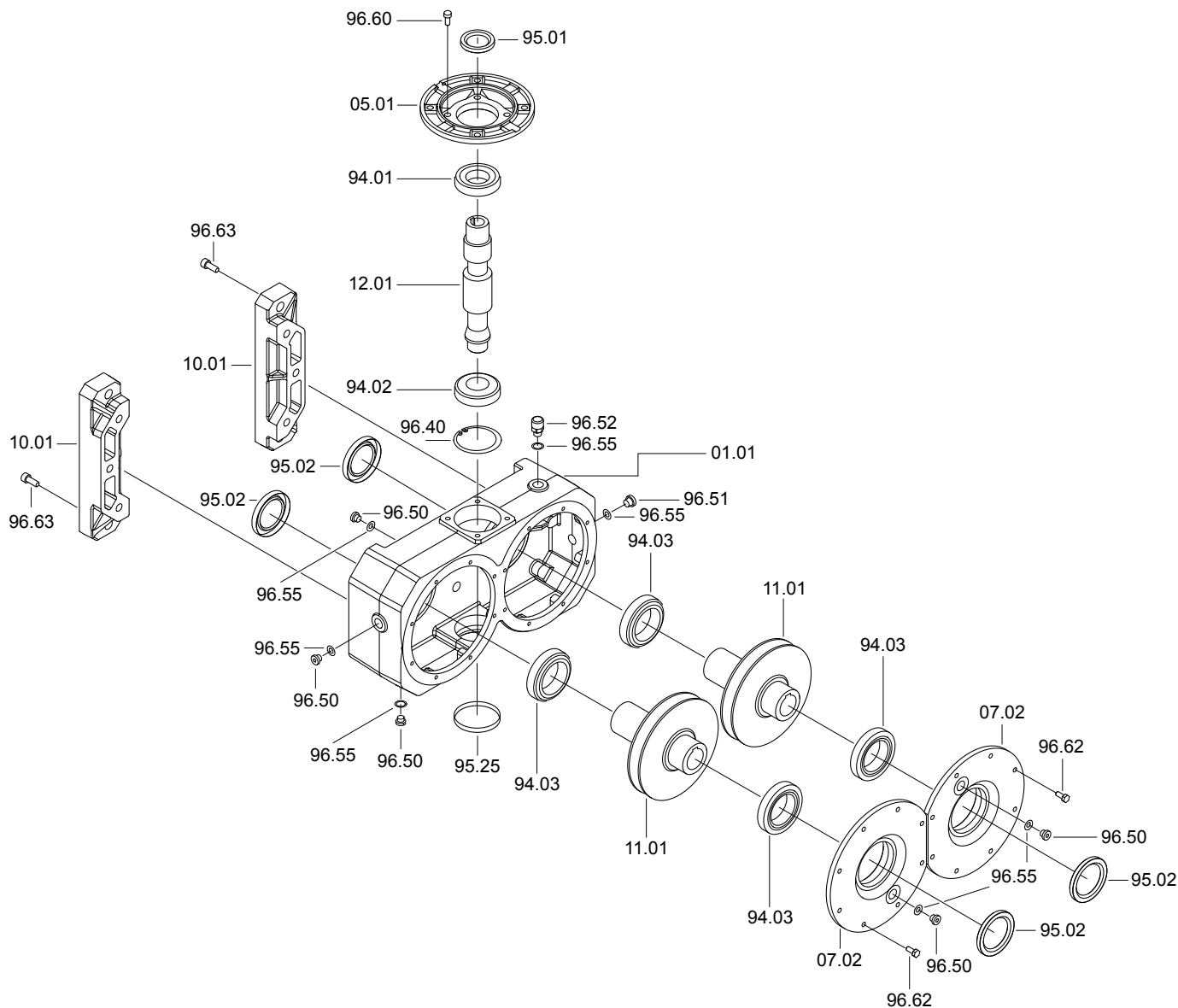

VM	Cuscinetti / Bearings / Lager			Anelli di tenuta / Oilseals Öldichtungen		Cappellotto / Closed oil seal Geschlossene Öldichtung
	94.01	94.02	94.03	95.01	95.02	95.25
230	30208 40x80x19.75	30307 35x80x22.75	32012 60x95x23	40/72/7	60/85/8	ø 80x10

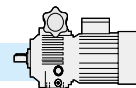

7.0	VARIATORI	VARIATORS	VERSTELLGETRIEBE	
7.1	Principio di funzionamento	<i>Variator operating principle</i>	Betriebsprinzip	122
7.2	Variatori	<i>Variators</i>	Verstellgetriebe	123
7.3	Caratteristiche	<i>Features</i>	Eigenschaften	123
7.4	Designazione	<i>Designation</i>	Bezeichnung	124
7.5	Dati tecnici	<i>Technical data</i>	Technische Angaben	126
7.6	Lubrificazione	<i>Lubrication</i>	Schmierung	127
7.7	Posizioni di montaggio	<i>Mounting positions</i>	Einbaulagen	128
7.8	Dimensioni	<i>Dimensions</i>	Abmessungen	129

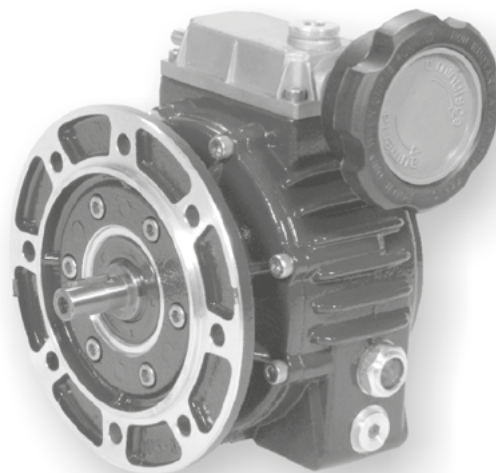

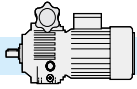

7.1 Principio di funzionamento del variatore

Si tratta di una trasmissione epicicloidale a rapporto variabile. Quando il motore aziona il solare (5-6), i satelliti (8) sono indotti a ruotare sul proprio asse e, contemporaneamente, per effetto del vincolo con la pista esterna fissa (7) e la pista esterna mobile (9), ad un movimento di rivoluzione che trascina in rotazione il portasatelliti (albero uscita). Variando la posizione assiale della pista esterna mobile (9) tramite la vite di comando, l'anello portasfere (14) e la camma fissa (15), i satelliti sono costretti a variare la loro posizione radiale di rivoluzione. In tal modo i diametri di rotolamento cambiano, così come la velocità angolare dell'albero uscita. Quando il contatto di rotolamento con le piste esterne (7) (9) si trova verso il centro del satellite (8), la velocità di rivoluzione è più bassa: l'albero uscita ruoterà più lentamente ma avrà disponibile un maggior momento torcente.

Attenzione

La regolazione della velocità si può effettuare SOLO col variatore in funzione, MAI a macchina ferma.

7.1 Variator operating principle

The mechanical variator working is based on an epicyclical transmission at variable ratio. When the motor drives the solar ring (5-6) the satellites (8) start to rotate on their axis and simultaneously, because of the connection with the fixed outer ring (7) and external mobile ring (9), originate the rotation of the satellite carrier (output shaft). The satellites rotate around their axes while simultaneously originate the rotation of the satellite carrier (output shaft). Changing the axial position of the external mobile ring (9) by means of the drive shaft, the ball support ring (14) and the fixed cam, the satellites are forced to modify their radial position rotation involving both the modification of the rolling diameters and the angular speed of the output shaft. When the rolling contact point of the outer rings (7) (9) is near the center of satellites (8) the output speed is very low: the output shaft will rotate more slowly but will dispose of a higher output torque.

Warning

Speed adjustment is only possible when variator is running, never adjust speed while variator is stationary. This will result in damage to the variator.

7.1 Betriebsprinzip

Das Verstellgetriebe ist ein Planetengetriebe mit verstellbarem Untersetzungsverhältnis. Der Motor treibt das Sonnenrad (5-6) an. Die Drehbewegung wird auf die Planetenräder (8) übertragen. Die Verbindung zwischen der unbeweglichen (7) und der beweglichen (9) äußeren Laufbahn überträgt die Drehbewegung an die Abtriebswelle. Durch die Verschiebung des Kugelringes (14) und der Nocke (15) ändert sich die Axiallage der beweglichen Laufbahn (9) und die Radiallage der Planetenräder. Auf diese Weise ändern die Rollendurchmesser und die Winkelgeschwindigkeit der Abtriebswelle. Verschiebt sich der Kontaktpunkt zwischen den Planetenrädern (7) und der äußeren Laufbahn (9) gegen das Zentrum der Planetenräder, sinkt die Ausgangsdrehzahl und das Drehmoment steigt.

Vorsicht

Die Geschwindigkeit darf nur während des Betriebes geändert werden.

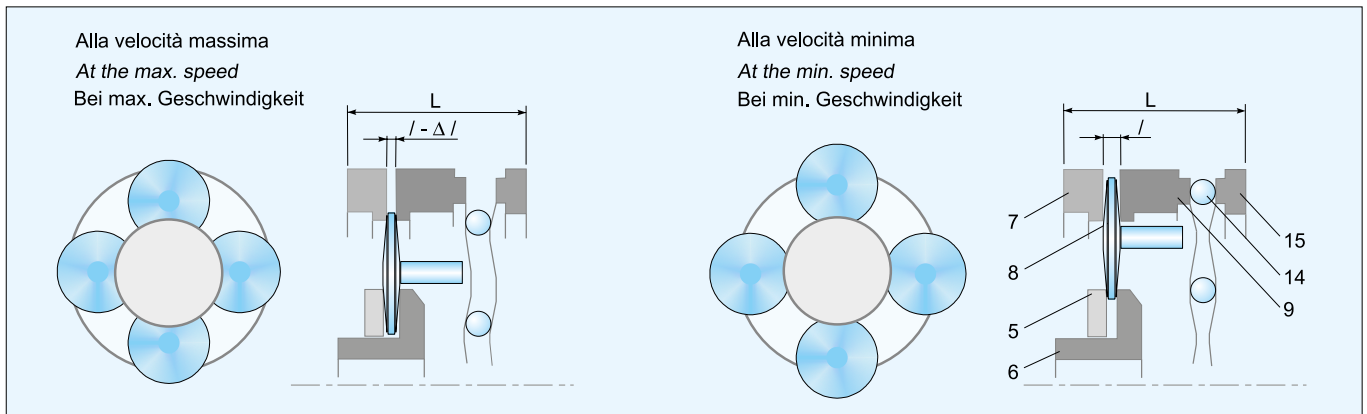

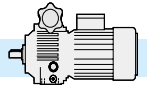

7.2 Variatori

I variatori meccanici serie N sono in alluminio nelle grandezze 003, 005, 010, 020, 030, 050 per potenze da 0.18 kW a 4 kW.

7.2 Variators

Mechanical variators N serie size 003, 005, 010, 020, 030 and 050, from 0.18 kW to 4 kW are made of aluminium.

7.2 Verstellgetriebe

Die mechanischen Verstellgetriebe Serie N sind aus Aluminium in den Größen 003, 005, 010, 020, 030, 050 für Leistungen von 0,18 kW bis 4 kW.

7.3 Caratteristiche

- La carcassa in alluminio, oltre ad una migliore estetica, comporta un minor peso del variatore rendendone più convenienti applicazioni e trasporti.
- Sul modulo base è possibile montare, in modo semplice e veloce, flangia uscita o piede, a seconda delle necessità. Questo riduce i volumi di stoccaggio ed i tempi di consegna.
- Il lato di entrata del variatore è chiuso, parte integrale col corpo: questo rende più facile l'installazione ed elimina totalmente la possibilità di perdite d'olio.
- È previsto, come standard, il collegamento a motori a dimensioni IEC forma B5.
- Il tappo di scarico olio è del tipo a magnete: la lubrificazione più pulita consente intervalli di manutenzione più lunghi.
- Funzionamento in bagno d'olio, silenzioso, con elevato rendimento ed esente da vibrazioni.
- Il funzionamento è possibile in entrambi i sensi di rotazione con entrata ed uscita concordi.
- Campo di variazione 1 - 6.
- L'albero di comando è bisporgente ed è quindi accessibile, per la manovra, da entrambe le estremità.

7.3 Characteristics

- *Alluminium housing benefits weight reduction for more convenient applications and transportation.*
- *The simple design allows both foot or output flange mounting to standard unit, reducing stocking levels and allowing quick delivery.*
- *The closed input flange is an integral part of the variator casing for easy installation and prevents possibility of oil leaks.*
- *IEC B5 motor connections available as standard.*
- *The magnetic breather plug maintains a clean lubrication and extends maintenance intervals.*
- *The oil bath operation provides high efficiency for noiseless, vibration free running.*
- *The unit can operate in both directions, input and output shafts rotate in same direction.*
- *Range of variation 1 - 6 reduction.*
- *Hand wheel can be fitted to both sides of control box for convenient installation.*

7.3 Merkmale

- Dank dem Gehäuse aus Aluminium ist das Verstellgetriebe sehr leicht, was zur erleichterten Anwendung und Transport dient.
- Auf das Grundmodul können entweder Abtriebsflansch oder Fuß montiert werden. Das bringt Raumersparnis und schnellere Lieferzeit mit sich.
- Die Antriebsseite ist geschlossen und integrales Bestandteil des Gehäuses: Installation ist einfacher und Ölverluste sind ausgeschlossen.
- Standard-Anbau zu IEC B5 Motoren.
- Magnet-Ölablassschraube: die reinigere Schmierung erlaubt längeren Wartungsintervallen.
- Betrieb im Ölbad ist geräuschlos, mit erhöhter Leistung und vibrationsfrei.
- Betrieb ist in beide Drehrichtungen möglich, mit Antriebs- und Abtriebswellen in derselber Richtung drehend.
- Variationsbreite 1 – 6
- Das Steuer-Handrad ist doppelseitig hervorstehend: es kann von beiden Enden bedient werden.

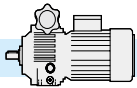

7.4 Designazione

7.4 Designation

7.4 Bezeichnung

Tipo Type Typ	Grandezza Size Größe	Albero uscita diam. mm Output shaft diam. mm Abtriebswelle Durchmesser mm	Flangia uscita diam. mm Output flange diam. mm Abtriebsflansch Durchmesser mm	Attacco motore IEC IEC motor adaptor IEC Motoranbau	Posizione di montaggio Mounting position Einbaulage	Posizione scatola di comando Speed control box position Steuerkasten	Potenza motore Motor power Motorleistung	N° poli Poles number Polzahl	Forma costruttiva motore Motor version Motorversion	Tensione Voltage Spannung	Frequenza Frequency Frequenz	Posizione morsetteria Terminal box position Lage der Klemmkaste
NF	030	AU28	F250	100B5	B5	SA	2.2 kW	4	B5	230/400	50Hz	MA
N NM NF NK NMK NFK	003 005 010 020 030 050	Vedi tabelle <i>See tables</i> Siehe Tabelle	Vedi tabelle <i>See tables</i> Siehe Tabelle	Vedi tabelle <i>See tables</i> Siehe Tabelle	B3 B6 B7 B8 V5 V6 B5 V1 V3	SA SB SC SD	Vedi tabelle <i>See tables</i> Siehe Tabelle	2 4 6	B5			MA MB MC MD

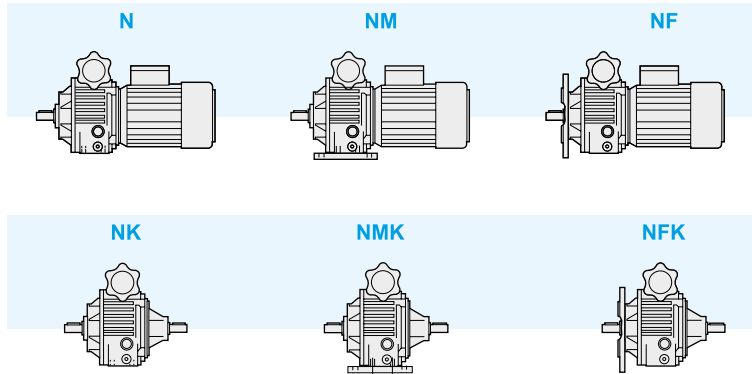

Posizione morsetteria e scatola di comando

Terminal box and speed control box position

Lage der Klemmkaste und der Steuerkaste

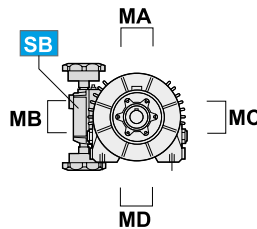
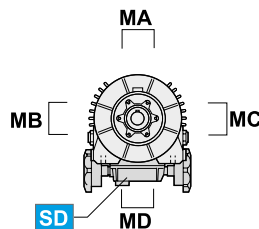
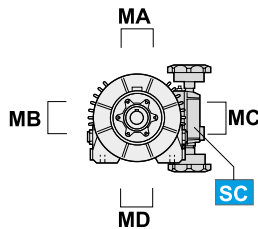
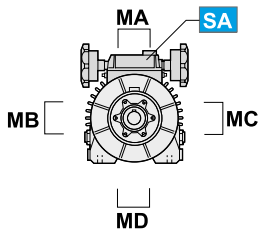

MA, MB, MC, MD
Posizione morsetteria
Terminal box position
Lage der Klemmkaste

SA, SB, SC, SD
Posizione scatola di comando
Speed control box position
Lager der Steuerkaste

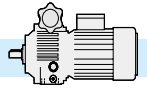

7.4 Designazione

7.4 Designation

7.4 Bezeichnung

Tipo Type Typ	Grandezza Size Größe	Rapporto di riduzione (i) Reduction ratio (i) Unteretzungsverhältnis	Albero uscita diam. mm Output shaft diam. mm Abtriebswelle Durchmesser mm	Flangia uscita diam. mm Output flange diam. mm Abtriebsflansch Durchmesser mm	Attacco motore IEC IEC motor adaptor IEC Motoranbau	Posizione di montaggio Mounting position Einbaulage	Posizione scatola di comando Speed control box position Steuerkasten	Potenza motore Motor power Motorleistung	N° poli Poles number Polzahl	Forma costruttiva motore Motor version Motorversion	Tensione Voltage Spannung	Frequenza Frequency Frequenz	Posizione morsettiere Terminal box position Lage der Klemmkaste
NFR	003/1	5	AU19	F160	63B5	B5	SA	0.25 kW	4	B5	230/400	50Hz	MA
NRT NRM NRF NRTK NRMK NRFK	003/1 005/1 010/1 020/1 030/1 050/1	2.5 5	Vedi tabelle <i>See tables</i> Siehe Tabelle	Vedi tabelle <i>See tables</i> Siehe Tabelle	Vedi tabelle <i>See tables</i> Siehe Tabelle	B3 B6 B7 B8 V5 V6 B5 V1 V3	SA SB SC SD	Vedi tabelle <i>See tables</i> Siehe Tabelle	2 4 6	B5			MA MB MC MD

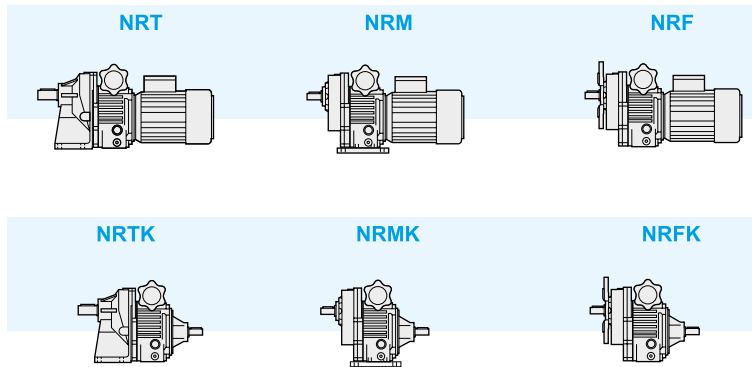

Posizione morsettiere e scatola di comando

Terminal box and speed control box position

Lage der Klemmkaste und der Steuerkaste

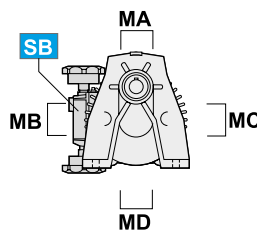
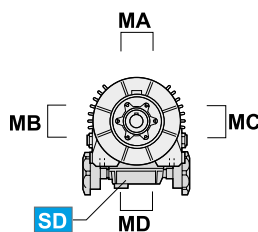
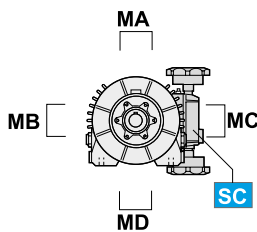
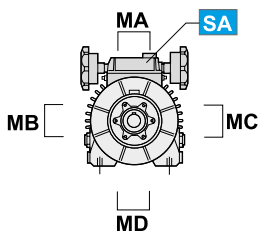

MA, MB, MC, MD
Posizione morsettiere
Terminal box position
Lage der Klemmkaste

SA, SB, SC, SD
Posizione scatola di comando
Speed control box position
Lage der Steuerkaste

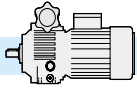

7.5 Dati tecnici

7.5 Technical data

7.5 Technische Angaben

Tipo Type Typ	P ₁ kW	Poli Poles Polen	Attacco motore IEC IEC motor adaptor IEC Motoranbau	n ₂ max min ⁻¹	n ₂ min min ⁻¹	i	T ₂ min Nm	T ₂ max Nm
N003	0.25	4	63 B5	950	190	—	1.9	3.8
	0.37	2	63 B5	1900	380	—	1.5	3
NR 003/1	0.25	4	63 B5	380	76	2.5	4.7	9.3
				190	38	5	9.3	18.6
N005	0.37	4	71 B5	1000	167	—	3	6
	0.55	4	71 B5	1000	167	—	4.5	9
	0.75	2	71 B5	2000	333	—	3	6
NR 005/1	0.37	4	71 B5	400	67	2.5	7.3	14.7
				200	33	5	14.7	29.4
N010	0.75	4	80 B5	1000	167	—	6	12
	0.92	4	80 B5	1000	167	—	7.5	12
	1.5	2	80 B5	2000	333	—	6	12
NR 010/1	0.75	4	80 B5	400	67	2.5	14.7	29.4
				200	33	5	29.4	58.8
N020	1.5	4	90 B5	1000	167	—	12	24
	1.85	4	90 B5	1000	167	—	15	24
	2.2	2	90 B5	2000	333	—	9	18
NR 020/1	1.5	4	90 B5	400	67	2.5	29.4	58.8
				200	33	5	58.8	118
N030	2.2	6	100 B5	660	125	—	27	54
	2.2	4	100 B5	1000	167	—	18	36
	3	4	100 B5	1000	167	—	24	48
NR 030/1	2.2	4	100 B5	400	67	2.5	44.1	88.2
				200	33	5	88.2	176
N050	4	4	112 B5	1000	167	—	32	64
NR 050/1	4	4	112 B5	400	67	2.5	78.4	157
				200	33	5	157	314

Simbologia:

P₁ [kW] Potenza motore
poli N° poli motore
n₂ max [min⁻¹] Velocità massima in uscita
n₂ min [min⁻¹] Velocità minima in uscita
T₂ min [Nm] Coppia alla velocità massima
T₂ max [Nm] Coppia alla velocità minima
i Rapporto di riduzione

Symbols:

P₁ [kW] Motor power
poles Number of poles
n₂ max [min⁻¹] Max output speed
n₂ min [min⁻¹] Min output speed
T₂ min [Nm] Output torque at the max speed
T₂ max [Nm] Output torque at the min speed
i Reduction ratio

Symbole:

P₁ [kW] Motorleistung
poli Motor Polzahl
n₂ max [min⁻¹] Max Abtriebsdrehzahl
n₂ min [min⁻¹] Min. Abtriebsdrehzahl
T₂ min [Nm] Drehmoment bei max. Drehzahl
T₂ max [Nm] Drehmoment bei min. Drehzahl
i Untersetzungsverhältnis

Il diagramma A riporta i valori indicativi del rendimento del variatore alle varie velocità in uscita n₂ espresse in min⁻¹ e il diagramma B indica la percentuale di carico sul motore.

Diagram A shows the indicative value of efficiency in relation to output speed n₂ expressed in min⁻¹. Diagram B shows the percentage of motor output power utilized.

Diagramm A zeigt die Richtwerte des Wirkungsgrades in Abhängigkeit zur Abtriebsdrehzahl n₂ Min⁻¹. Diagramm B zeigt den Prozentsatz der benötigten Motorleistung.

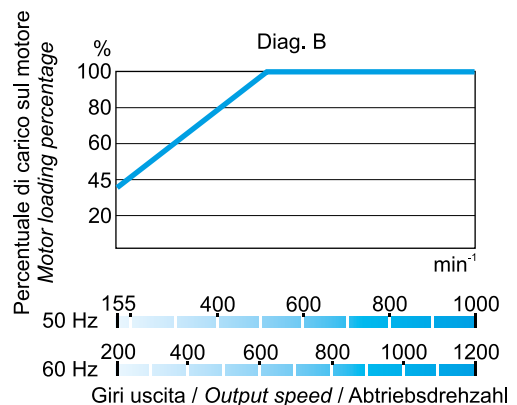
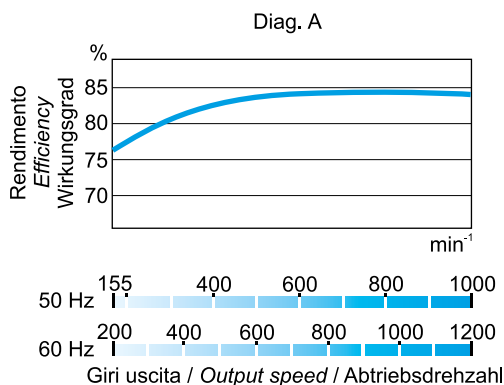

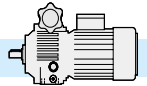

I diagrammi seguenti riportano le curve di coppia riferite alle varie potenze applicate e al numero di giri in entrata al variatore n_1 (min^{-1}).

The following diagrams show the performance for output torque in relation to input power and input speed n_1 (min^{-1}).

Die folgende Diagramme zeigen die Drehmomentkurven bezüglich Leistung und Antriebsdrehzahl.

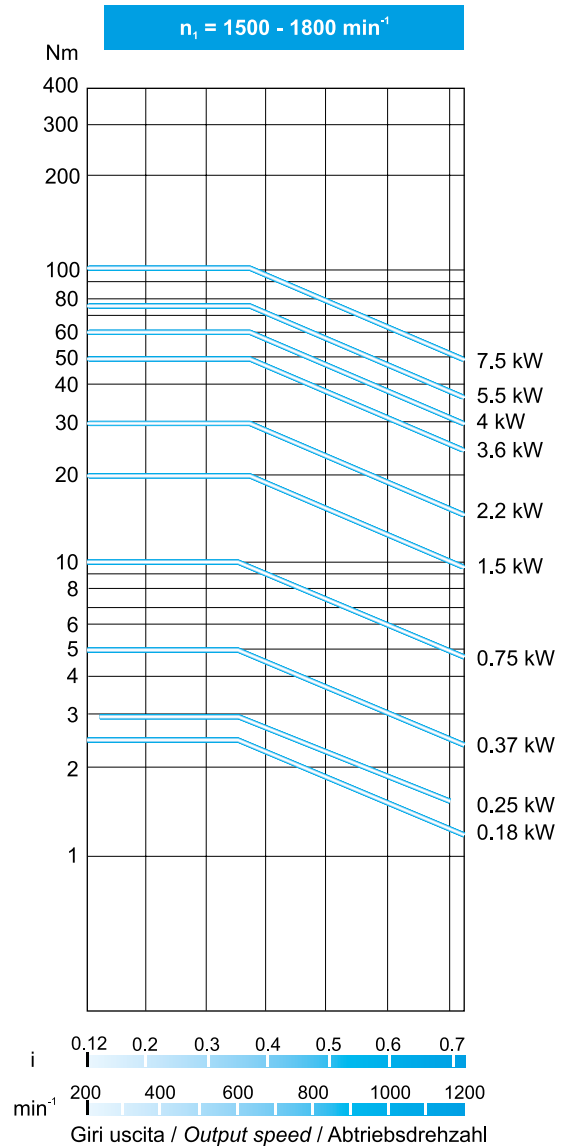
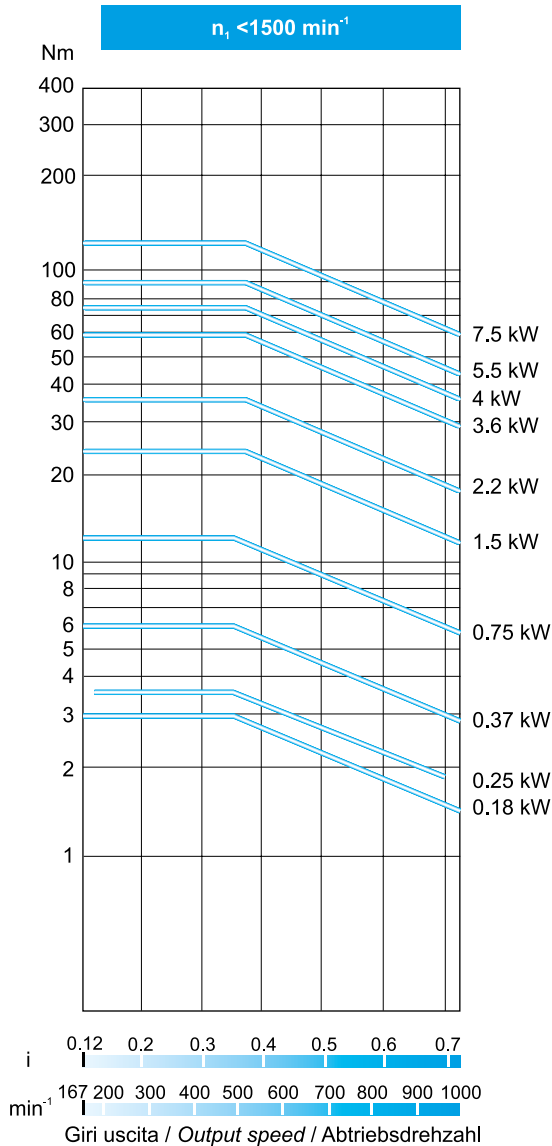

7.6 Lubrificazione

I variatori vengono forniti completi di lubrificante. Dopo il piazzamento del variatore assicurarsi che il livello del lubrificante sia visibile dall'apposita spia di livello effettuando eventuali rabbocchi se necessario, con un analogo lubrificante scelto fra quelli raccomandati in tabella.

7.6 Lubrication

The variators are supplied complete with lubricant. It is important to have the correct level of lubrication for the final mounting position chosen. Ensure the oil can be seen through the oil level plug this to allow the filling up if necessary.

7.6 Schmierung

Die Verstellgetriebe werden mit Öl geliefert. Nach Einbau des Verstellgetriebes ist der Ölstand durch das Schauglas zu prüfen. Wenn notwendig, füllen Sie mit einem der empfohlenen Öle auf (s. Tafel).

Tipi di lubrificanti raccomandati / Recommended lubricants / Empfohlene Öle			
Dexron fluid II	IP		
A.T.F. Dexron fluid DIII	SHELL		
A.T.F. 200 RED	MOBIL		
A.T.F. Dexron	FINA		
BP Autran DX	BP		
A.T.F. Dexron	ESSO		
A.T.F. Dexron	CHEVRON		
A.T.F. Dexron	AGIP		
		Atina grease 0	IP
		Tivela Compound A	SHELL

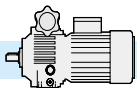

7.7 Posizioni di montaggio

7.7 Mounting positions

7.7 Einbaulagen

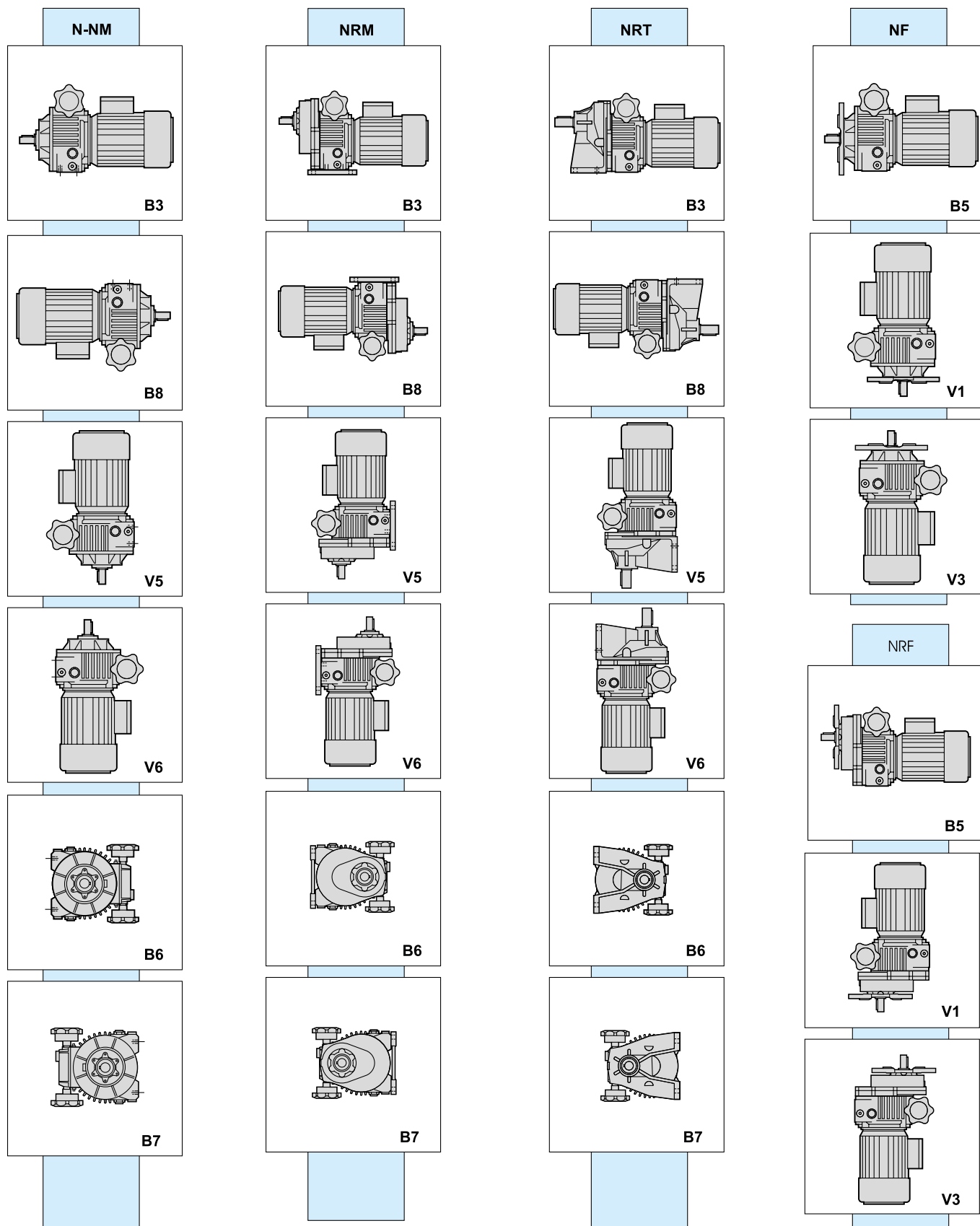

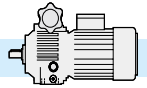

7.8 Dimensioni

7.8 Dimensions

7.8 Abmessungen

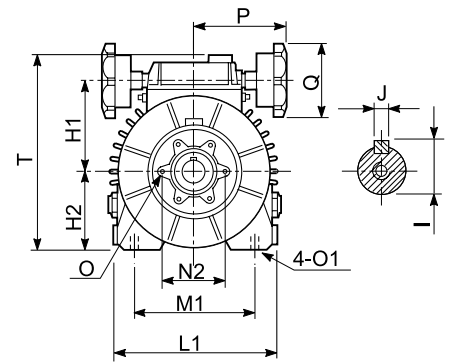
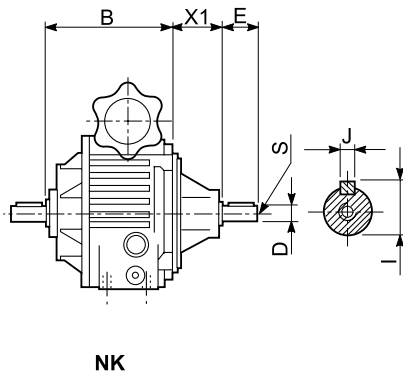
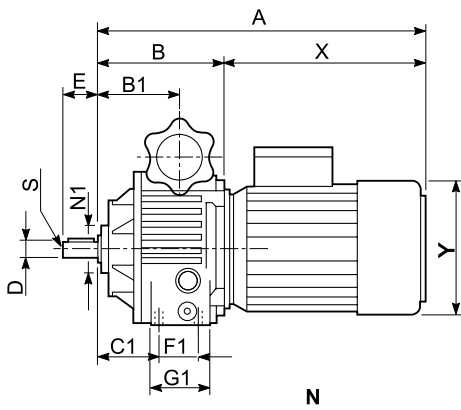

Tipo Type Typ	A	B	B1	C1	D	E	F1	G1	H1	H2	I	J	L1	M1	N1	N2	O	O1	P	Q	S	T	X	X1	Y	Kg
N003	302	110	66	44	11	23	36	55	79	58	12.5	4	128	100	42	56	M6	M8	97	89	M5	160	192	42	122	5
N005	336	118	78	61	14	30	36	55	88	73	16	5	153	120	56	75	M6	M8	97	89	M6	185	218	50	137	7
N010	383	145	95	75	19	40	45	82	107	91	21.5	6	187	140	56	75	M6	M10	107	89	M6	222	239	65	158	13
N020	450	172	105	82	24	50	58	82	126	108	27	8	220	190	75	100	M8	M10	107	89	M8	264	278	70	177	20

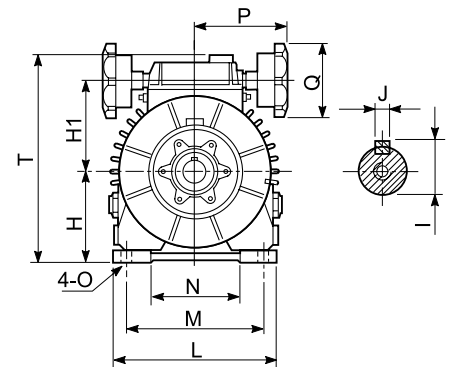
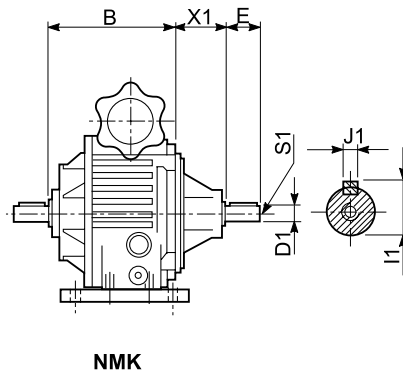
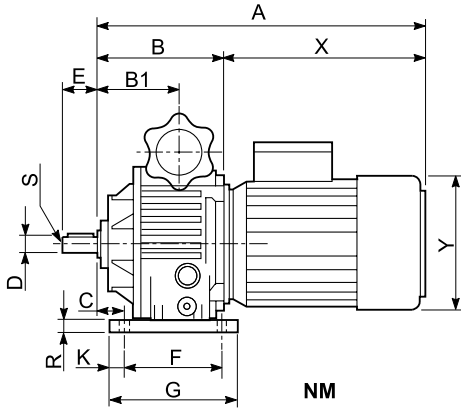

Tipo Type Typ	A	B	B1	C	D	D1	E	F	G	H	H1	I	I1	J	J1	K	L	M	N	O	P	Q	R	S	S1	T	X	X1	Y	Kg
NM003	302	110	66	25	11 (14)	11	23 (30)	105	130	71	76	12.5 (16)	12.5	4 (5)	4	12.5	140	110	80	9	97	89	11	M5 (M6)	M5	173	192	42	122	6
NM005	336	118	78	30	14 (19)	14	30 (40)	105	130	90	88	16 (21.5)	16	5 (6)	5	12.5	155	120	83	10	97	89	13	M6	M6	202	218	50	137	8
NM010	382	143	95	35	19 (24)	19	40 (50)	125	150	106	107	21.5 (27)	21.5	6 (8)	6	12.5	190	160	120	12	107	89	13.5	M6 (M8)	M6	242	239	65	158	14
NM020	441	171	104	50	24 (28)	24	50 (60)	140	165	125	126	27 (31)	27	8	8	12.5	230	180	130	12	107	89	16	M8 (M10)	M8	277	270	70	177	21
NM030/050	546	206	122	25	28 (38)	28	60 (80)	230	270	150	158	31 (41)	31	8 (10)	8	20	300	245	190	14	155	120	20	M10 (M12)	M10	337	340	95	197	51

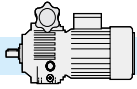

7.8 Dimensioni

7.8 Dimensions

7.8 Abmessungen

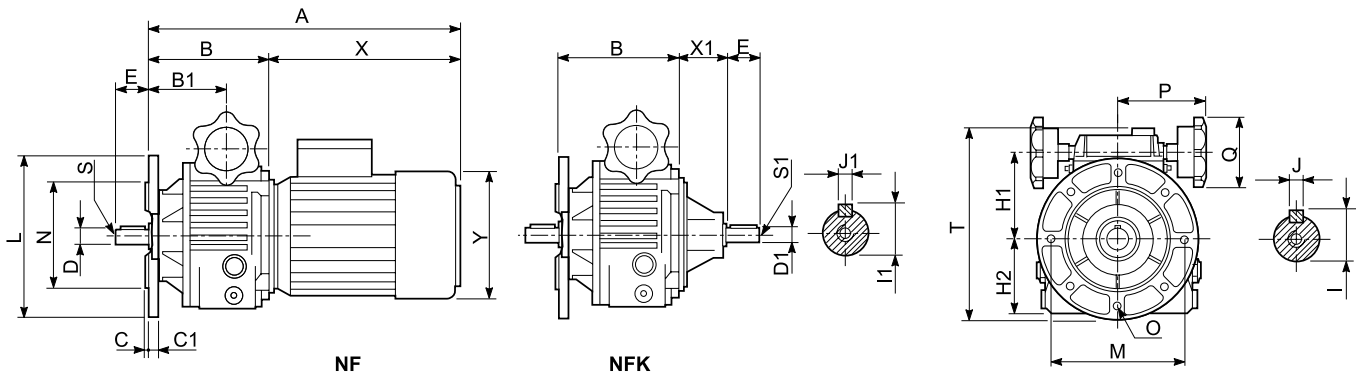

Tipo Type Typ	A	B	B1	C	C1	D	D1	E	H1	H2	I	I1	J	J1	L	M	N	O	P	Q	S	S1	T	X	X1	Y	Kg
NF003	302	110	66	3.5	8	11 (14)	11	23 (28)	76	58	12.5 (16)	12.5	4 (5)	4	140 (160)	115 (130)	95 (110)	9 (9)	97	89	M5	M5	165 (175)	192	42	122	6
NF005	338	120	80	3.5	10.5	14 (19)	14	28 (38)	88	73	16 (21.5)	16	5 (6)	5	160 (200)	130 (165)	110 (130)	9 (11)	97	89	M6	M6	188 (208)	218	50	137	8
NF010	384	145	97	3.5	13.5	19 (24)	19	38 (48)	107	91	21.5 (27)	21.5	6 (8)	6	200	165	130	11	107	89	M6 (M8)	M6	237	239	65	158	14
NF020	443	173	106	4	14	24 (28)	24	48 (58)	126	108	27 (31)	27	8	8	200 (250)	165 (215)	130 (180)	11 (14)	107	89	M8 (M10)	M8	260 (277)	270	70	177	21
NF030/050	548	208	124	4(5)	16	28 (38)	28	58 (78)	158	134	31 (41)	31	8 (10)	8	250 (300)	215 (265)	180 (230)	14	155	120	M10 (M12)	M10	336	340	95	197	51

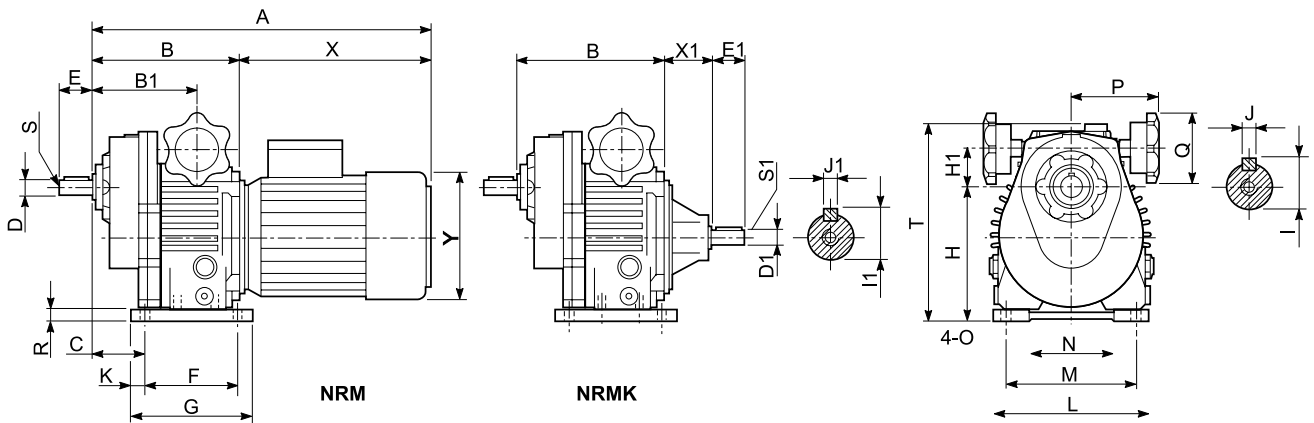

Tipo Type Typ	A	B	B1	C	D	D1	E	E1	F	G	H	H1	I	I1	J	J1	K	L	M	N	O	P	Q	R	S	S1	T	X	X1	Y	Kg
NRM003	331	139	108	57	19 (20)	11	30	23	105	130	111 (116)	36	21.5 (22.5)	12.5	6	4	12.5	140	110	80	9	97	89	11	M6	M5	173	192	42	122	7
NRM005	363	145	105	54	19 (20)	14	30	30	105	130	140 (135)	38	21.5 (22.5)	16	6	5	12.5	155	120	83	10	97	89	13	M6	M6	202	218	50	137	11
NRM010	418	179	131	69	24 (25)	19	35	40	125	150	169 (160)	44	27 (28)	21.5	8	6	12.5	190	160	120	12	107	89	13.5	M8	M6	242	239	65	158	9
NRM020	471	201	135	78	28 (30)	24	45	50	140	165	188 (190)	63	31 (33)	27	8	8	12.5	230	180	130	12	107	89	16	M10	M8	277	270	70	177	33
NRM030 NRM050	586	246	165	63	38 (40)	28	60	60	230	270	230 (224)	78	41 (43)	31	10 (12)	8	20	300	245	190	14	155	120	20	M12	M8	337	340	95	197	75

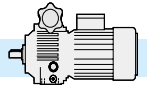

7.8 Dimensioni

7.8 Dimensions

7.8 Abmessungen

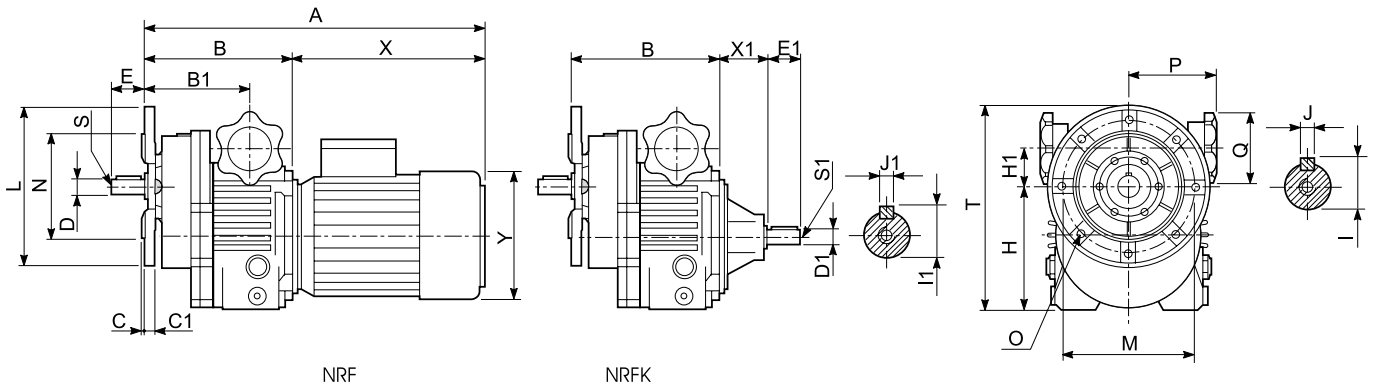

Tipo Type Typ	A	B	B1	C	C1	D	D1	E	E1	H	H1	I	I1	J	J1	L	M	N	O	P	Q	S	S1	T	X	X1	Y	Kg
NRF003	333	141	112	3.5	8	19	11	28	23	98	36	21.5	12.5	6	4	160	130	110	9	97	89	M6	M5	178	192	42	122	7
NRF005	372	154	114	3.5	10.5	19	14	28	30	123	38	21.5	16	6	5	160	130	110	9	97	89	M6	M6	203	218	50	137	11
NRF010	419	180	130	3.5	13.5	24	19	33	40	154	44	27	21.5	8	6	200	165	130	11	107	89	M8	M6	254	239	65	158	19
NRF020	473	203	137	4	14	28	24	43	50	171	63	31	27	8	8	250	215	180	14	107	89	M10	M8	296	270	70	177	33
NRF030/050	588	248	167	4	16	38	28	58	60	214	78	41	31	10	8	300	265	230	14	155	120	M12	M8	364	340	95	197	75

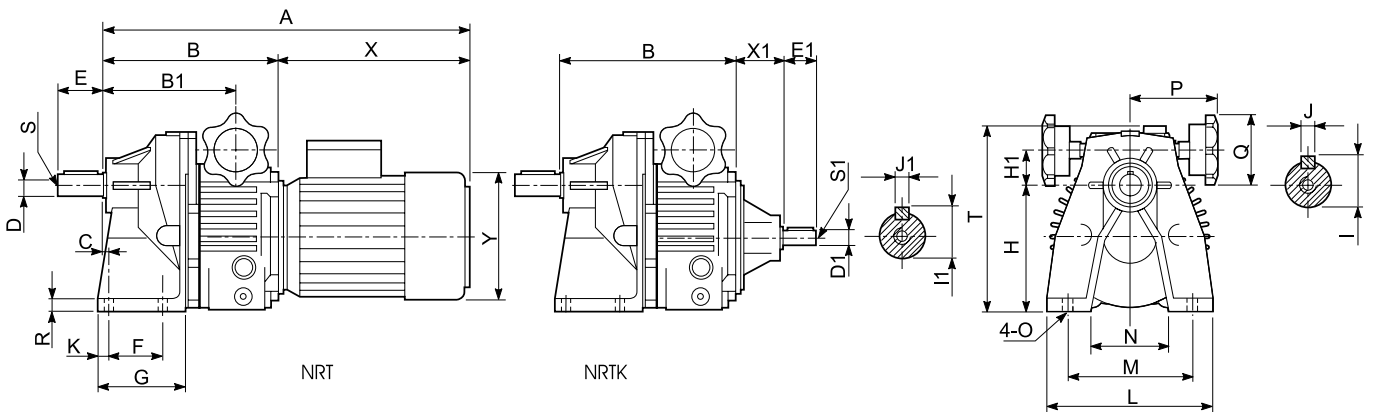

Tipo Type Typ	A	B	B1	C	D	D1	E	E1	F	G	H	H1	I	I1	J	J1	K	L	M	N	O	P	Q	R	S	S1	T	X	X1	Y	Kg
NRT003	376	184	140	20	19	11	40	23	45	80	110	36	21.5	12.5	6	4	14	130	105	70	9	97	89	10	M6	M5	167	192	42	122	9
NRT005	412	194	154	6	24	14	50	30	70	110	130	38	27	16	8	5	15	180	150	90	11	97	89	12	M8	M6	192	218	50	137	13
NRT010	456	218	171	7.5	28	19	60	40	70	115	163	44	31	21.5	8	6	14	215	165	100	11	107	89	15	M8	M6	231	239	65	158	21
NRT020	551	281	215	25	38	24	70	50	85	142	195	46	41	27	10	8	23	250	185	130	14	107	120	16	M10	M8	266	270	70	177	33
NRT030/050	686	346	261	19	48	28	100	60	130	178	250	59	51.5	31	14	8	17	310	240	160	17	155	120	18	M10	M8	337	340	95	197	75

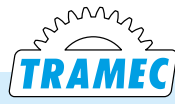
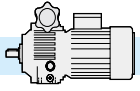

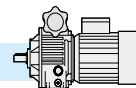

8.0

VARIATORI UDL

VARIATORS UDL

VERSTELLGETRIEBE UDL

8.1	Principio di funzionamento	<i>Variator operating principle</i>	Betriebsprinzip	134
8.2	Variatori	<i>Variators</i>	Verstellgetriebe	135
8.3	Caratteristiche	<i>Features</i>	Eigenschaften	135
8.4	Designazione	<i>Designation</i>	Bezeichnung	136
8.5	Dati tecnici	<i>Technical data</i>	Technische Angaben	136
8.6	Lubrificazione	<i>Lubrication</i>	Schmierung	136
8.7	Posizioni di montaggio	<i>Mounting positions</i>	Einbaulagen	137
8.8	Dimensioni	<i>Dimensions</i>	Abmessungen	137

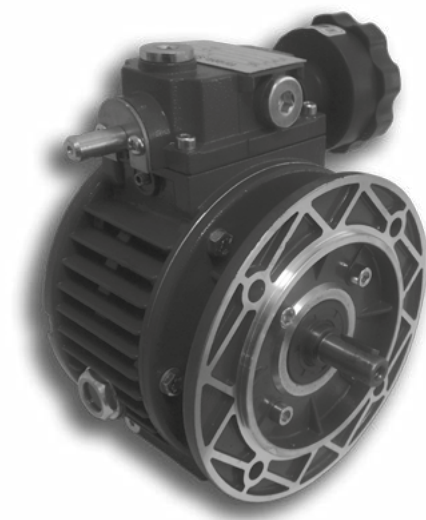

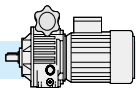

8.1 Principio di funzionamento del variatore

Si tratta di una trasmissione epicicloidale a rapporto variabile.

Quando il motore aziona il solare (5-6), i satelliti (8) sono indotti a ruotare sul proprio asse e, contemporaneamente, per effetto del vincolo con la pista esterna fissa (7) e la pista esterna mobile (9), ad un movimento di rivoluzione che trascina in rotazione il portasatelliti (albero uscita).

Variando la posizione assiale della pista esterna mobile (9) tramite la vite di comando, l'anello portasfere (14) e la camma fissa (15), i satelliti sono costretti a variare la loro posizione radiale di rivoluzione. In tal modo i diametri di rotolamento cambiano, così come la velocità angolare dell'albero uscita.

Quando il contatto di rotolamento con le piste esterne (7) (9) si trova verso il centro del satellite (8), la velocità di rivoluzione è più bassa: l'albero uscita ruoterà più lentamente ma avrà disponibile un maggior momento torcente.

Attenzione

La regolazione della velocità si può effettuare SOLO col variatore in funzione, MAI a macchina ferma.

8.1 Variator operating principle

The mechanical variator is based on an epicyclic transmission for variable ratios.

The motor rotates the solar rings (5-6) which rotate the satellites (8). In turn these are in contact with the fixed outer ring (7) and external mobile ring (9).

The satellites rotate around their axes while simultaneously originate the rotation of the satellite carrier (output shaft).

When the rolling contact point of the outer rings (7) (9) is near the center of satellites (8) the output speed will reduce: the output shaft will rotate more slowly thus increasing the output torque value.

Warning

Speed adjustment is only possible when variator is running, never adjust speed while variator is stationary.

This will result in damage to the variator.

8.1 Funktionsprinzip des Verstellgetriebes

Das Verstellgetriebe ist ein Planetengetriebe mit verstellbarem Untersetzungsverhältnis.

Der Motor treibt das Sonnenrad (5-6) an. Die Drehbewegung wird auf die Planetenräder (8) übertragen. Die Verbindung zwischen der unbeweglichen (7) und der beweglichen (9) äußeren Laufbahn überträgt die Drehbewegung an die Abtriebswelle.

Durch die Verschiebung des Kugelringes (14) und der Nocke (15) ändert sich die Axiallage der beweglichen Laufbahn (9) und die Radiallage der Planetenräder. Auf diese Weise ändern sich den Rollendurchmesser und die Winkelgeschwindigkeit der Abtriebswelle.

Verschiebt sich der Kontaktpunkt zwischen den Planetenrädern (7) und der äußeren Laufbahn (9) gegen das Zentrum der Planetenräder, sinkt die Ausgangsdrehzahl und das Drehmoment steigt.

Vorsicht

Die Geschwindigkeit darf nur verstellt werden, wenn das Verstellgetriebe im Betrieb ist und nicht wenn es still steht. Andernfalls kommt es zu einer Beschädigung des Verstellgetriebes.

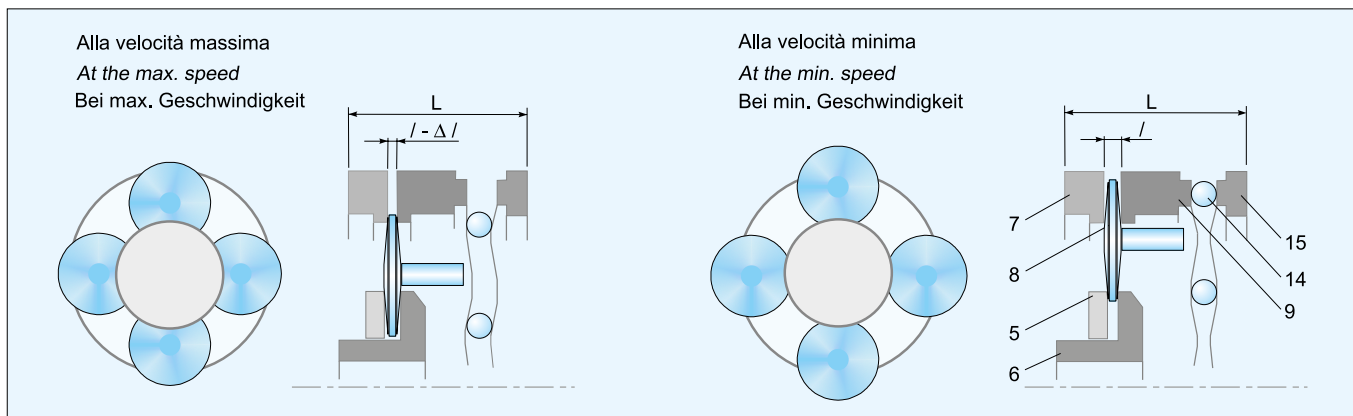

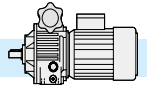

8.2 Variatori

La gamma dei variatori di velocità TRAMEC si completa con la nuova serie UDL, grandezze disponibili 002, 005 e 010.

8.2 Variators

The present range of Tramec speed reducers has been completed by the new UDL Series available in 3 sizes: 002, 005 and 010

8.2 Verstellgetriebe

Die aktuelle Tramec Variatoren - Serie wird ergänzt durch die neue UDL Serie. Sie ist in den Größen 002, 005 und 010 erhältlich.

8.3 Caratteristiche

- La carcassa in alluminio, oltre ad una migliore estetica, comporta un minor peso del variatore rendendone più convenienti applicazioni e trasporti.
- Sul modulo base è possibile montare, in modo semplice e veloce, flangia uscita o piede, a seconda delle necessità. Questo riduce i volumi di stoccaggio ed i tempi di consegna.
- Il lato di entrata del variatore è chiuso, parte integrale col corpo: questo rende più facile l'installazione ed elimina totalmente la possibilità di perdite d'olio.
- È previsto, come standard, il collegamento a motori a dimensioni IEC forma B5.
- Il tappo di scarico olio è del tipo a magnete: la lubrificazione più pulita consente intervalli di manutenzione più lunghi.
- Funzionamento in bagno d'olio, silenzioso, con elevato rendimento ed esente da vibrazioni.
- Il funzionamento è possibile in entrambi i sensi di rotazione con entrata ed uscita concordi.

8.3 Characteristics

- *The aluminium housing benefits weight reduction for more convenient applications and transportation.*
- *The simple design allows both foot or flange mounting to standard unit, reducing stocking levels and allowing quick delivery.*
- *The closed input flange is an integral part of the variator casing for easy installation and prevents possibility of oil leaks.*
- *IEC B5 motor connections available as standard.*
- *The magnetic breather plug maintains a clean lubricant and extends maintenance intervals.*
- *The oil bath operation provides high efficiency for noiseless and vibration free running.*
- *The unit can operate in both directions, input and output shafts rotate in the same direction.*

8.3 Merkmale

- Dank dem Gehäuse aus Aluminium ist das Verstellgetriebe sehr leicht, was zur erleichterten Anwendung und Transport dient.
- Auf das Grundmodul können entweder Abtriebsflansch oder Fuß montiert werden. Das bringt Raumersparnis und schnellere Lieferzeit mit sich.
- Die Antriebsseite ist geschlossen und integrales Bestandteil des Gehäuses: Installation ist einfacher und Ölverluste sind ausgeschlossen.
- Standard-Anbau zu IEC B5 Motoren.
- Magnet-Ölablassschraube: die reinigere Schmierung erlaubt längere Wartungsintervalle.
- Betrieb im Ölbad ist geräuschlos, mit erhöhter Leistung und vibrationsfrei.
- Betrieb ist in beide Drehrichtungen möglich, mit Antriebs- und Abtriebswellen in derselben Richtung drehend.

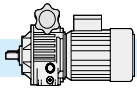

8.4 Designazione

8.4 Designation

8.4 Bezeichnung

Tipo Type Typ	Grandezza Size Größe	Albero uscita diam. mm Output shaft diam. mm Abtriebswelle Durchmesser mm	Flangia uscita diam. mm Output flange diam. mm Abtriebsflansch Durchmesser mm	Attacco motore IEC IEC motor adaptor IEC Motoranbau	Posizione di montaggio Mounting position Einbaulage	Potenza motore Motor power Motorleistung	N° poli Poles number Polzahl	Forma costruttiva motore Motor version Motorversion	Tensione Voltage Spannung	Frequenza Frequency Frequenz
UDL	010	AU19	F200	80B5	B5	0.75 kW	4	B5	230/400	50Hz
UDL	002 005 010	AU 11 AU 14 AU 19	F 140 F 160 F 200	63 B5 71 B5 80 B5	B5 V1 V3	0.18 0.25 0.37 0.55 0.75	4	B5	230/400	50Hz

8.5 Dati tecnici

8.5 Technical data

8.5 Technische Angaben

Tipo Type Typ	P ₁ kW	Poli Poles Polen	Attacco motore IEC IEC motor adaptor IEC Motoranbau	n ₂ max min ⁻¹	n ₂ min min ⁻¹	T ₂ min Nm	T ₂ max Nm
UDL 002	0.18	4	63 B5	880	170	1.5	3
UDL 005	0.25	4	71 B5	1000	200	2	6
	0.37			1000	200	3	6
UDL 010	0.55	4	80 B5	1000	200	4.4	12
	0.75	4		1000	200	6	12

8.6 Lubrificazione

8.6 Lubrification

8.6 Schmierung

I variatori vengono forniti completi di lubrificante. Dopo il piazzamento del variatore assicurarsi che il livello del lubrificante sia visibile dall'apposita spia di livello effettuando eventuali rabbocchi se necessario, con un analogo lubrificante scelto fra quelli raccomandati in tabella.

The variators are supplied complete with lubricant. After the mounting pls make sure the oil can be seen through the oil level plug this to allow the filling up if necessary. Oil has to be selected among the recommended ones.

Die Verstellgetriebe werden mit Schmiermittel geliefert. Nach Einbau des Verstellgetriebes ist der Ölstand durch das Schauglas zu prüfen. Wenn nötig, füllen Sie mit einem der empfohlenen Öle auf (siehe Tabelle).

Tipi di lubrificanti raccomandati / Recommended lubricants / Empfohlene Öle	
Dexron fluid II	IP
A.T.F. Dexron fluid DIII	SHELL
A.T.F. 200 RED	MOBIL
A.T.F. Dexron	FINA
BP Autran DX	BP
A.T.F. Dexron	ESSO
A.T.F. Dexron	CHEVRON
A.T.F. Dexron	AGIP

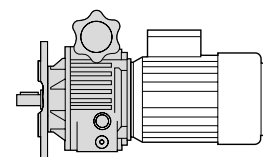

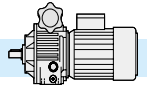

8.7 Posizioni di montaggio

8.7 Mounting positions

8.7 Einbaulagen

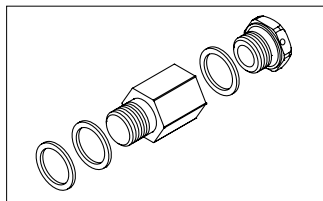
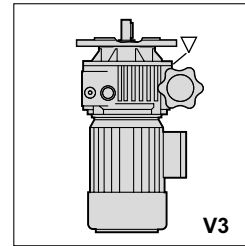
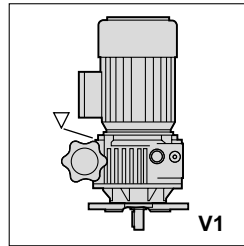
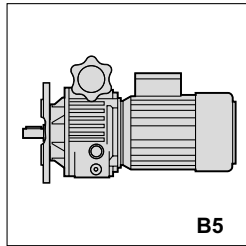

- ▽ Kit Tappo di sfiato
solo per posizione di montaggio V1, V3
- ▽ Kit breather plug
only for mounting positions V1, V3
- ▽ Kit Entlüftungsschraube
Nur für die Einbaulagen V1, V3

8.8 Dimensioni

8.8 Dimensions

8.8 Abmessungen

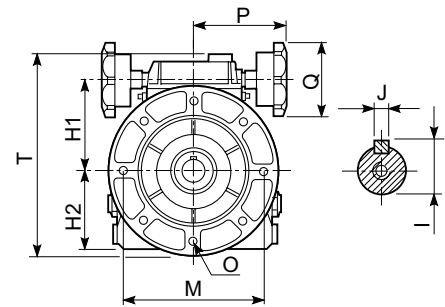
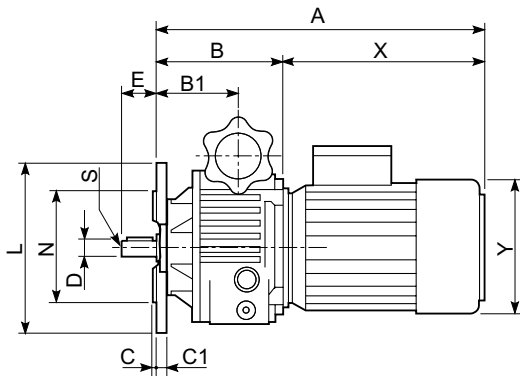

Tipo Type Typ	A	B	B1	C	C1	D	H1	H2	I	J	L	M	N	O	P	Q	S	T	X	Y	kg
UDL 002	318.5	111.5	64	3.5	6.5	11	78	70	12.5	4	140	115	95	9	113	70	M5	183	207	130	3.3
UDL 005	333	108	71.5	3.5	8.5	14	91	80	16	5	160	130	110	9	113	70	M5	205	225	145	4.6
UDL 010	398.5	143.5	87.5	3.5	10.5	19	107	100	21.5	6	200	165	130	11	120	85	M6	242	255	175	7.9

I valori A, X, Y e kg dipendono dal motore utilizzato

The values A, X, Y and kg depend on the electric motor used.

Die Werte A, X, Y und kg auf den Elektromotor abhängen

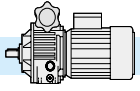

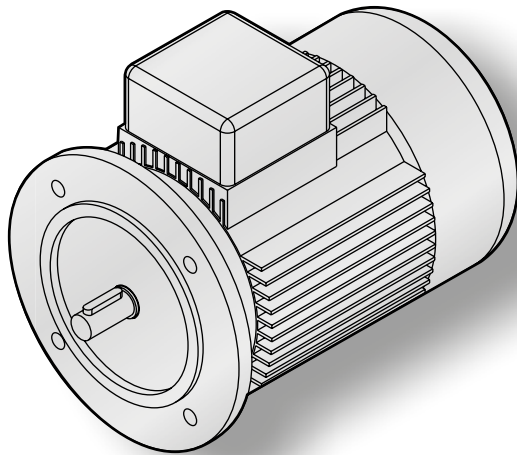

B5

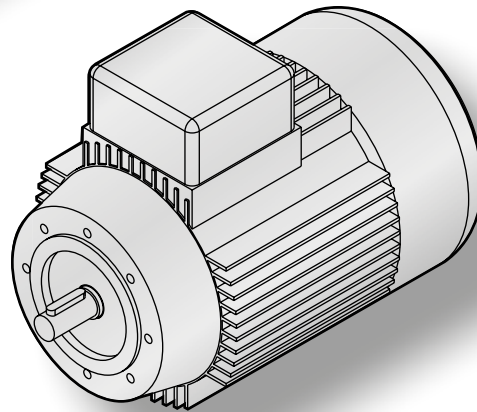

B14

B5

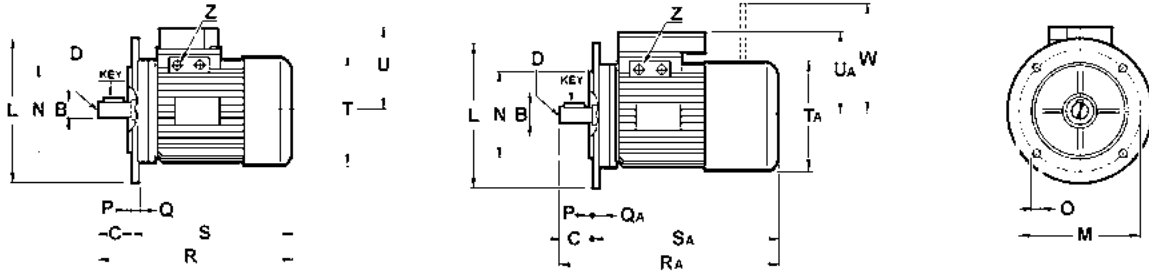

Motori elettrici ⁽¹⁾
Electric motors
Elektromotoren

Motori elettrici autofrenanti ⁽²⁾
Electric brake motors
Elektro-Bremsmotoren

	4 poles	kW	kg. (1)	kg. (2)	B	C	D	L	M	N	O	P	Q	QA	R	RA	S	SA	T	TA	U	UA	W	Z	KEY
56	A	0.06	2.5	4	9	20	M4	120	100	80	7	3	8	8	188	220	168	200	110	110	108	108	90	PG11	3x3x15
	B	0.09	2.6	5																				PG11	3x3x15
	C	0.11	3.2	5																				PG11	3x3x15
63	A	0.13	3.7	5	11	23	M4	140	115	95	9	3	9	9	208	257	185	234	123	123	110	110	98	PG11	4x4x15
	B	0.18	4.3	7																				PG11	
	C	0.22	4.3	7																				PG11	
71	A	0.25	5.8	8	14	30	M5	160	130	110	9	3.5	9	9	245	297	215	267	140	140	121	121	98	PG11	5x5x20
	B	0.37	6.2	8																				PG11	
	C	0.55	7.4	9																				PG11	
80	A	0.55	8.5	11	19	40	M6	200	165	130	11	3.5	10	10	278	336	238	296	159	159	138	138	111	PG16	6x6x30
	B	0.75	9.8	13																				PG16	
	C	0.9	10.5	13.5																				PG16	
90	S	1.1	12	17	24	50	M8	200	165	130	11	3.5	10	10	305	369	255	319	176	176	149	149	129	PG16	8x7x35
	L	1.5	13.5	18											330	394	280	344						PG16	
	LB	1.8	15.5	20											PG16										
100	A	2.2	19	25.5	28	60	M10	250	215	180	14	4	14	14	369	434	309	374	195	195	160	160	139	PG16	8x7x45
	B	3	21	28																				PG16	
	BL	4	23	30																				PG16	
112	A	4	29	38	28	60	M10	250	215	180	14	4	14	14	388	467	328	407	219	219	172	172	161	PG16	8x7x45
	BL	5.5	35	44																				PG16	
	S	5.5	43	56																				448	
132	M	7.5	52	66	38	80	M12	300	265	230	14	4	20	14	485	600	405	520	258	258	192	192	186	PG21	10x8x60
	ML	9.2	54	68											485	600	405	520	258	258	192	192	186	PG21	
	S	5.5	43	56											448	570	368	490	258	258	192	192	186	PG21	

Le dimensioni dei motori elettrici sono puramente indicative.

The dimensions of the electric motors are approximate values.

Die Abmessungen der Elektromotoren sind Näherungswerte.

B14

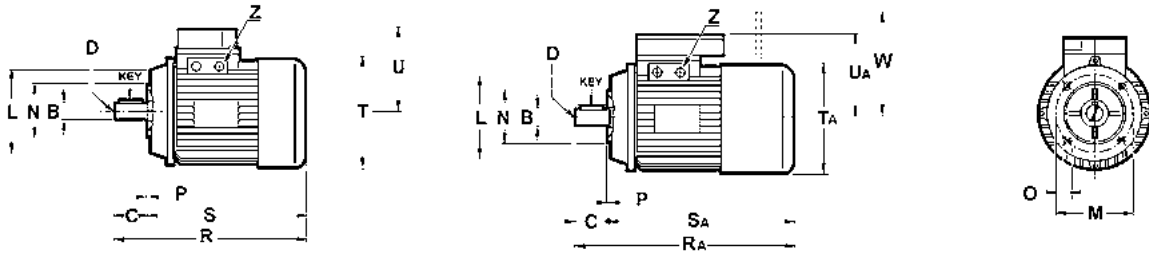

Motori elettrici ⁽¹⁾
Electric motors
Elektromotoren

Motori elettrici autofrenanti ⁽²⁾
Electric brake motors
Elektro-Bremsmotoren

	4 poles	kW	kg. (1)	kg. (2)	B	C	D	L	M	N	O	P	R	RA	S	SA	T	TA	U	UA	W	Z	KEY	
56	A	0.06	2.5	4	9	20	M4	80	65	50	M5	2.5	188	220	168	200	110	110	108	108	90	PG11	3x3x15	
	B	0.09	2.6	5																		PG11	3x3x15	
	C	0.11	3.2	5																		PG11	3x3x15	
63	A	0.13	3.7	5	11	23	M4	90	75	60	M5	2.5	208	257	185	234	123	123	110	110	98	PG11	4x4x15	
	B	0.18	4.3	7																		PG11		
	C	0.22	4.3	7																		PG11		
71	A	0.25	5.8	8	14	30	M5	105	85	70	M6	2.5	245	297	215	267	140	140	121	121	98	PG11	5x5x20	
	B	0.37	6.2	8																		PG11		
	C	0.55	7.4	9																		PG11		
80	A	0.55	8.5	11	19	40	M6	120	100	80	M6	3	278	336	238	296	158	159	138	138	111	PG16	6x6x30	
	B	0.75	9.8	13																		PG16		
	C	0.9	10.5	13.5																		PG16		
90	S	1.1	12	17	24	50	M8	140	115	95	M8	3	305	369	255	319	176	176	149	149	129	PG16	8x7x35	
	L	1.5	13.5	18									330	394	280	344								160
	LB	1.8	15.5	20																				
100	A	2.2	19	25.5	28	60	M10	160	130	110	M8	3.5	369	434	309	374	195	195	173	160	139	PG16	8x7x45	
	B	3	21	28																				
	BL	4	23	30																				
112	A	4	29	38	28	60	M10	160	130	110	M8	3.5	388	467	328	407	219	219	192	172	161	PG16	8x7x45	
	BL	5.5	35	44																		PG16	8x7x45	
132	S	5.5	43	56	38	80	M12	200	165	130	M10	4	448	570	368	490	258	258	192	192	186	PG21	10x8x60	
	M	7.5	52	66									485	600	405	520								
	ML	9.2	54	68																				

Le dimensioni dei motori elettrici sono puramente indicative.

The dimensions of the electric motors are approximate values.

Die Abmessungen der Elektromotoren sind Näherungswerte.



CONDIZIONI GENERALI DI GARANZIA

La garanzia relativa a difetti di costruzione ha la durata di un anno dalla data di fatturazione delle merce. Tale garanzia comporta per la TRAMEC l'onere della sostituzione o riparazione delle parti difettose ma non ammette ulteriore addebiti per eventuali danni diretti o indiretti di qualsiasi natura. La garanzia decade nel caso in cui non siano state osservate le disposizioni riportate nel manuale di uso e manutenzione e/o siano state eseguite riparazioni o apportate modifiche senza nostro consenso scritto.

La merce di ritorno sarà da noi accettata solo se spedita franco di ogni spesa.

WARRANTY GENERAL CONDITIONS

Gearboxes are covered for manufacturing defects by a one-year warranty from their invoicing date. TRAMEC will replace or repair defective parts but will not accept any further charges for direct or indirect damages of any kind. The warranty will become null and void if the instructions given in the use and maintenance manual are not complied with or if repairs or changes are carried out without our prior written authorization.

Returned goods will be accepted only if delivered free of any charge.

ALLGEMEINE GARANTIEBEDINGUNGEN

Die Garantie auf Herstellungsfehler dauert ein Jahr ab Rechnungsdatum. Aufgrund Garantie unterliegt der TRAMEC die Pflicht der Ersetzung oder Reparatur der defekten Teile, jedoch nicht die Übernahme weiterer Belastungen für direkte oder indirekte Schäden egal welcher Natur. Die Garantie verfällt bei Nichtbeachtung der in der betreffenden „Betriebs- und Instandhaltungsanleitung“ angeführten Anweisungen und/oder falls ohne unsere vorausgehende schriftliche Genehmigung Reparaturen oder Änderungen vorgenommen wurden.

Die an uns zurückgesendete Ware akzeptieren wir nur wenn gebührenfrei geliefert.

REVISIONI

10/2010 - Inserita nuova grandezza 130.
03/2011 - Kit di protezione albero cavo disponibile nella grandezza 130.
01/2012 - Modificate quantità di olio a pag.18,45,68,92,93.
- Limitatore L1 nei combinati non più disponibile.
06/2012 - Inserito rapporto 5 su grandezza 30-40-50-63.
- Inseriti nuovi alberi lenti.

10/14
- Inserita nuova serie UDL
- Inseriti cusc. conici corona tavole ricambi
11/2015 - Modifica tolleranza albero cavo
04/16
- Modificata q.tà olio pos. B6-B7 gr. 30, 40, 50, 63 e 75

REVISIONS

10/2010 - New size 130 added.
03/2011 - Hollow shaft protection cover available for the size 130.
01/2012 - Modified oil quantity at page 18,45,68,92,93.
- L1 torque in combined gearboxes limiter not available anymore.
06/2012 - Ratio 5 for sizes 30-40-50-63 has been added
- Added new output solid shafts.

10/14
- NEW UDL Series included
- Included tapered roller bearings in spare parts
-11/2015 Modification tolerance output hollow shaft
04/16
Modification oil quantity mounting positions B6-B7 size 30, 40, 50, 63, 75

ÄNDERUNG

10/2010 - Größe 130 eingefügt.
03/2011 - Schutzvorrichtung fuer die Hohlwelle BG 130.
01/2012 - Ändern Menge Öl auf pag.18,45,68,92,93.
- Im kombinierten L1 Limiter ist nicht mehr verfügbar.
06/2012 - Untersetzungsverhältnis 5 fuer Getriebegröße 30-40-50-63 wurde eingefügt.
- Die neue Abtriebswellen wurden eingefügt.
10/14
- Einfügung der neuen Serie UDL
- Einfügung Kegelrollenlager in Ersatzteilliste
11/2015 Änderung Toleranz Antriebswelle
04/16
Änderung Schmiermittelmenge Einbaulagen B6-B7 30, 40, 50, 63, 75

04/2016

Questo catalogo annulla e sostituisce ogni precedente edizione o revisione. Tutti i dati elencati sono indicativi e s'intendono senza impegno alcuno da parte nostra. Ci riserviamo il diritto di apportare modifiche senza preavviso.

This catalogue cancels and replaces any previous edition and revision. All listed data are approximate and it's understood that this entails no obligation on our part. We reserve the right to implement modifications without notice.

Mit der Ausgabe dieses Katalogs annullieren sich gleichzeitig alle bisherigen Katalogen. Sämtliche Daten sind Berechnete Werte die für den Verkäufer unverbindlich sind. Der Verkäufer behält sich das Recht vor, Änderungen, ohne eine vorhergehende Advisierung durchzuführen.