

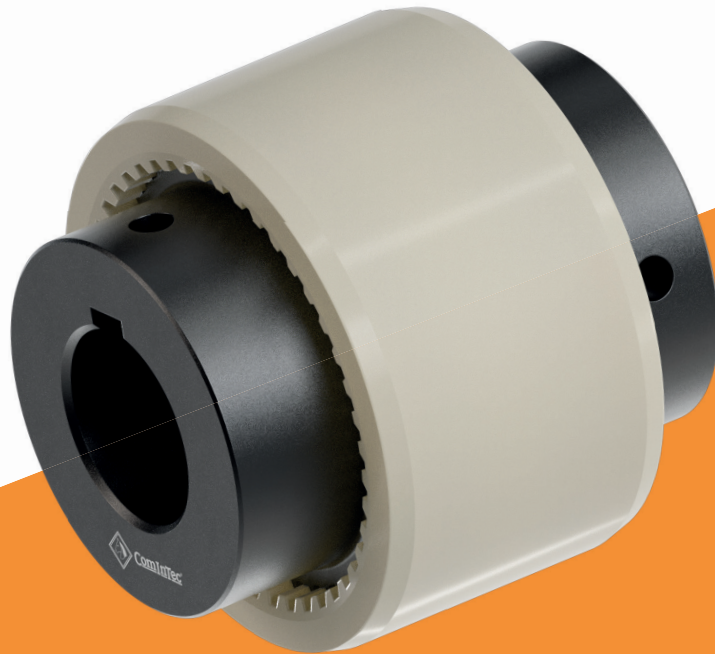

**ComInTec**<sup>®</sup>  
Safety in Power Transmission

# GEAR COUPLING

up to 5,000 Nm and 125 mm bore diameters



Ed.04/2024



- Download catalog
- Download instruction sheets

# GD

## GD - gear coupling: introduction

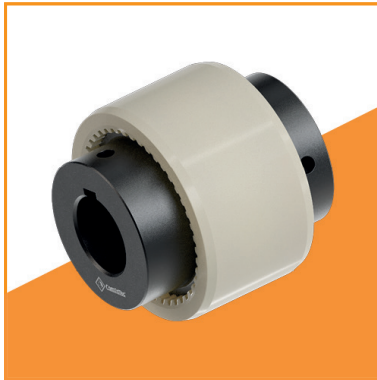

- Hubs made in steel fully turned with standard treatment of phosphating.
- Polyamide sleeve.
- Statically balanced.
- Maintenance and lubrication free.
- Compact and simple to be assembled.
- Vibrations dampening.

### ON REQUEST

- Various hub connection type available.
- Version with sleeve in steel, circlip and seals.
- Version with sleeve directly integrated in one hub.
- Specific surface treatments possible.

The GD coupling is composed of two hubs in steel UNI EN ISO 683-1:2018 fully turned, externally toothed with rounded profile and assembled only with a sleeve in polyamide stabilized resin, toothed internally.

Due to the tooth profile with which the hubs and the sleeve are connected, you can obtain a high contact surface also in presence of misalignments, in order to reduce the contact pressures and promote a longer life.

The connection polyamide/steel assures silent and reliable functioning, in absence of maintenance and lubrication.

This kind of coupling represents a reliable and economic kind of connection, for medium and big power industrial purposes.

### DESCRIPTION OF THE SLEEVE

The standard sleeve is made in polyamide 6.6 stabilized resin and its properties are as follows:

- Resistant to all common lubricants and hydraulic fluids
- Suitable to operate in a continuous way on temperatures from -25°C up to 90°C and for short periods up to 125°C
- Optimum sliding properties
- High insulating capacities
- Optimum mechanical properties

### DIMENSIONING

For pre-selection of the coupling's size you can use the generic formula indicated on page 6.

Having established the coupling's size to be used, it is possible to make other checks considering further parameters:

$$C_{nom} > C_{mot} \cdot f_T \cdot f_R$$

Where:

$C_{nom}$  = nominal torque of the coupling [Nm]  
 $C_{mot}$  = nominal torque motor side [Nm]  
 $C_{max}$  = maximum torque of the coupling [Nm]  
 $C_{SU}$  = starting torque motor side [Nm]  
 $C_{SM}$  = starting torque motor side [Nm]  
 $f_A$  = starting frequency factor  
 $f_R$  = thermic factor  
 $f_T$  = inertia motor side  
 $J_{mot}$  = inertia motor side [Kgm<sup>2</sup>]  
 $J_{uti}$  = inertia user side [Kgm<sup>2</sup>]  
 $K$  = shock factor

thermic factor ( $f_T$ )

1 = -40 ÷ +60 °C  
 1,2 = +70 °C  
 1,4 = +80 °C  
 1,6 = +90 °C

Shock factor (K)

1 = light shock  
 1,5 = medium shock  
 1,8 = hard shock

Starting frequency factor ( $f_A$ )

1 = 0 ÷ 120 starting each hour  
 1,2 = 240 starting each hour  
 1,4 = 400 starting each hour  
 1,6 = 800 starting each hour  
 1,8 = 1600 starting each hour

Considering la coppia di spunto:

$$C_{nom} = C_{SM} \cdot \frac{J_{uti}}{J_{mot} + J_{uti}} \cdot K \cdot f_T \cdot f_A + C_{mot} \cdot f_T \cdot f_R$$

$$C_{nom} = C_{SU} \cdot \frac{J_{uti}}{J_{mot} + J_{uti}} \cdot K \cdot f_T \cdot f_A + C_{mot} \cdot f_T \cdot f_R$$

It is important to consider that misalignments, axial, angular and parallel, must be considered paired together, as inversely proportional (one reduces when the other increases). If all types of misalignments occur then it is necessary that the sum in percentage respect to the maximum value doesn't exceed 100%.

### FITTING

Specific procedures to assemble this coupling are not required.

- 1) Achieve radial and axial alignment as precisely as possible to have the maximum absorption of possible misalignments and longer life of the coupling.
- 2) Having pre-assembled the coupling, insert the external half-hub on one shaft. Check that the external parts of the two shafts don't exceed the relevant half-hub's surface (quote "N") and fix this one to the shaft with its relevant fixing system.
- 3) Insert the sleeve on the two half-hubs being careful to respect the distance of the same half-hubs, quote "P" on the catalogue.
- 4) Before starting transmission be sure that the sleeve can move freely.

# GD - gear coupling: technical data

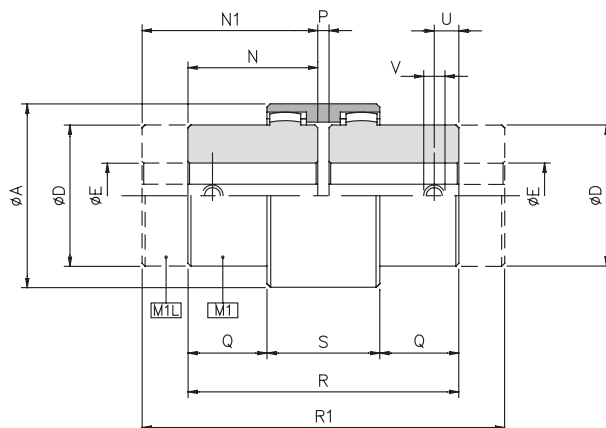

## DIMENSIONS

| Size       | A   | D   | E H7  |     | N   | N1   | P  | Q    | R   | R1    | S   | U  | V   |
|------------|-----|-----|-------|-----|-----|------|----|------|-----|-------|-----|----|-----|
|            |     |     | pilot | max |     |      |    |      |     |       |     |    |     |
| 1 (14)     | 40  | 24  | -     | 14  | 23  | 40   | 4  | 6,5  | 50  | 84    | 37  | 6  | M5  |
| 2 (19)     | 48  | 30  | -     | 19  | 25  | 40   | 4  | 8,5  | 54  | 84    | 37  | 6  | M5  |
| 3 (24)     | 52  | 36  | -     | 24  | 26  | 50   | 4  | 7,5  | 56  | 104   | 41  | 6  | M5  |
| 4 (28)     | 66  | 44  | -     | 28  | 40  | 55   | 4  | 19   | 84  | 114   | 46  | 10 | M8  |
| 5 (32)     | 76  | 50  | -     | 32  | 40  | 55   | 4  | 18   | 84  | 114   | 48  | 10 | M8  |
| 6 (38)     | 83  | 58  | -     | 38  | 40  | 60   | 4  | 18   | 84  | 124   | 48  | 10 | M8  |
| 7 (42)     | 92  | 65  | -     | 42  | 42  | ▲ 60 | 4  | 19   | 88  | ▲ 124 | 50  | 10 | M8  |
| 8 (48)     | 95  | 67  | -     | 48  | 50  | ▲ 60 | 4  | 27   | 104 | ▲ 124 | 50  | 10 | M8  |
| 9 (55)     | 114 | 82  | -     | 55  | 52  | ▲ 65 | 4  | 25   | 108 | ▲ 134 | 58  | 20 | M10 |
| 10 (65)    | 132 | 96  | -     | 65  | 55  | ▲ 70 | 4  | 23   | 114 | ▲ 144 | 68  | 15 | M10 |
| ▲ 11 (80)  | 175 | 124 | 25    | 80  | 90  | -    | 6  | 46,5 | 186 | -     | 93  | 20 | M10 |
| ▲ 12 (100) | 210 | 152 | 35    | 100 | 110 | -    | 8  | 63   | 228 | -     | 102 | 20 | M10 |
| ▲ 13 (125) | 270 | 192 | 45    | 125 | 140 | -    | 10 | 78   | 290 | -     | 134 | 20 | M10 |

## TECHNICAL CHARACTERISTICS

| Size       | Torque [Nm] |      | Weight [Kg] |      |        | Inertia [Kgm <sup>2</sup> ] |          |          | Max speed [Rpm] | Operating temperature [°C] | Misalignments |              |               |
|------------|-------------|------|-------------|------|--------|-----------------------------|----------|----------|-----------------|----------------------------|---------------|--------------|---------------|
|            | nom         | max  | M1          | M1L  | Sleeve | M1                          | M1L      | Sleeve   |                 |                            | Angular α [°] | Axial X [mm] | Radial K [mm] |
| 1 (14)     | 11,5        | 23   | 0,10        | 0,13 | 0,022  | 0,000010                    | 0,000013 | 0,000007 | 14000           | -25 ÷ +80                  | 2°            | ±1           | ±0,3          |
| 2 (19)     | 18,5        | 36,5 | 0,18        | 0,28 | 0,028  | 0,000018                    | 0,000032 | 0,000013 | 11800           |                            | 2°            | ±1           | ±0,4          |
| 3 (24)     | 23          | 46   | 0,23        | 0,42 | 0,037  | 0,000036                    | 0,000076 | 0,000020 | 10600           |                            | 2°            | ±1           | ±0,4          |
| 4 (28)     | 51,5        | 103  | 0,54        | 0,73 | 0,086  | 0,000122                    | 0,000187 | 0,000068 | 8500            |                            | 2°            | ±1           | ±0,5          |
| 5 (32)     | 69          | 138  | 0,66        | 0,90 | 0,104  | 0,000207                    | 0,000328 | 0,000116 | 7500            |                            | 2°            | ±1           | ±0,5          |
| 6 (38)     | 88          | 176  | 0,93        | 1,42 | 0,131  | 0,000394                    | 0,000787 | 0,000171 | 6700            |                            | 2°            | ±1           | ±0,4          |
| 7 (42)     | 110         | 220  | 1,10        | 1,46 | 0,187  | 0,000510                    | 0,001223 | 0,000286 | 6000            |                            | 2°            | ±1           | ±0,4          |
| 8 (48)     | 154         | 308  | 1,50        | 1,83 | 0,198  | 0,000744                    | 0,001445 | 0,000327 | 5600            |                            | 2°            | ±1           | ±0,4          |
| 9 (55)     | 285         | 570  | 2,30        | 3,26 | 0,357  | 0,001962                    | 0,003378 | 0,000741 | 4800            |                            | 2°            | ±1           | ±0,6          |
| 10 (65)    | 420         | 840  | 3,17        | 3,95 | 0,595  | 0,004068                    | 0,007586 | 0,001519 | 4000            |                            | 2°            | ±1           | ±0,6          |
| ▲ 11 (80)  | 700         | 1400 | 8,40        | -    | 1,130  | 0,015292                    | -        | 0,006471 | 3150            |                            | 2°            | ±1           | ±0,7          |
| ▲ 12 (100) | 1200        | 2400 | 15,37       | -    | 1,780  | 0,040213                    | -        | 0,015696 | 3000            |                            | 2°            | ±1           | ±0,8          |
| ▲ 13 (125) | 2500        | 5000 | 31,19       | -    | 3,880  | 0,137141                    | -        | 0,054469 | 2120            |                            | 2°            | ±1           | ±1,1          |

## NOTES

▲ On request

- The weights refer to the coupling with minimum bore.
- Inertias refer to the coupling with maximum bore.
- For choice and availability of different hub connection type see pages 4 and 5.

# GD - gear coupling: additional information

## ORDER EXAMPLE

| GEAR COUPLING |      |         |                       |                       |                       |                       |
|---------------|------|---------|-----------------------|-----------------------|-----------------------|-----------------------|
| Model         | Size | Version | Bore 1                | Hub connection bore 1 | Bore 2                | Hub connection bore 2 |
| GD            | 8    | M1 - M1 | d <sub>1</sub> =40 H7 | A1                    | d <sub>2</sub> =40 H7 | A1                    |

|              |                    |
|--------------|--------------------|
| <b>Model</b> | GD   gear coupling |
|--------------|--------------------|

|                |                     |
|----------------|---------------------|
| <b>Size</b>    | From 1 to 13        |
| <b>Version</b> | M1 - M1<br>M1 - M1L |

|                       |  |
|-----------------------|--|
| <b>Hub connection</b> | see hub connection type list at page 4 |
|-----------------------|--|