



ComInTec[®]
Safety in Power Transmission

COMPACT ELASTIC COUPLING

up to 105 kNm and 220 mm bore diameters



Ed.04/2024



- Download catalog
- Download instruction sheets

GEC

GEC - compact elastic coupling: introduction



- Made in steel fully turned with standard treatment of phosphating.
- Maintenance without removing the coupling
- Suitable for working in high temperatures.
- Statically balanced, suitable to absorb vibrations.
- Highest protection.
- Excellent value torque/dimensions.

ON REQUEST

- Various hub connection type available.
- Specific treatments or aluminum version fully turned available.
- Customised versions for specific needs including hub/flange connection.
- Connection to the Torque limiter's (safety coupling) range possible.

The GEC coupling is composed of two hubs in steel UNI EN ISO 683-1:2018 fully turned. These two hubs are connected by radial pins, made in steel with high resistance and seated within the elastomeric elements.

These pins, with their relevant elastomeric elements, are protected by an external band, allowing the coupling a high grade of protection.

This construction feature allows the user to be able to perform maintenance, by substituting the elastic elements, without the need to move the two transmission hubs/shafts, reducing maintenance times and optimizing the plant productivity.

Particularly suitable for connecting Pelton turbines, for the coupling between engines and worm compressors and in general for transmission where safety is highly necessary without compromising the quality and effectiveness of the same transmission.

DESCRIPTION OF THE ELASTOMERIC ELEMENT

The main features that distinguish this elastic element are as follows:

- Good resistance to all common lubricants and hydraulic fluids.
- Optimum mechanical properties.
- Green element suitable to operate for short periods up to 170 °C.

DIMENSIONING

For pre-selection of the coupling's size you can use the generic formula indicated on page 6. Alternatively it is possible to determine the coupling's nominal torque using several correction factors:

$$C_{nom} > C_{mot} \cdot f \cdot K \cdot f_T \cdot f_A$$

Where:
 C_{nom} = theoretic nominal torque of the coupling [Nm]
 C_{mot} = nominal torque motor side [Nm]
 f = service factor (see page 5)
 f_A = starting frequency factor [Hz]
 f_T = thermic factor
 K = shock factor

Shock factor (K)
 1,2 = light shock
 1,5 = medium shock
 1,8 = hard shock

Thermic factor (f_T)
 1 = -36 ÷ +60 °C
 1,2 = 80 °C
 1,4 = 100 °C
 1,8 = 120 °C

Starting frequency factor (f_A)
 1 = 0 ÷ 120 starting each hour
 1,2 = 240 starting each hour
 1,4 = 400 starting each hour
 1,6 = 800 starting each hour
 1,8 = 1600 starting each hour

Having completed and checked the coupling's choice, in accordance to the torque to be transmitted, it is necessary now, to take into consideration, the necessary flexibility comparing the misalignments allowed from the kind of coupling selected, with the real ones, seen by the shafts to be connected. It is important to consider that misalignments, axial, angular and parallel, must be considered paired together, as inversely proportional (one reduces when the other increases). If all types of misalignments occur, it is necessary that the sum in percentage respect to the maximum value doesn't exceed 100%.

FITTING

Specific procedures to assemble this coupling are not required.

- 1) Achieve radial and axial alignment as precisely as possible for maximum absorption of possible misalignments and the long life of the coupling.
- 2) Having pre-assembled the coupling, insert the external half-hub on one shaft. Check that the external parts of the two shafts don't exceed the relevant half-hub's surface (quote "N") and fix this one to the shaft with its relevant fixing system.
- 3) Close the second shaft inserting it into the internal half-hub for a quantity not higher than the length of the bore (quote "N"). If the insertion should be difficult, due to an accentuated misalignment, it is advisable to release all the connection pins, this will allow for a higher flexibility between the two half-hubs.
- 4) After having inserted and fixed the hubs, take away each connection pin, damp them with loctite threadlocker, and reassemble and tighten them carefully in progressive way following a cross sequence.
- 5) Cover the pins with the protection band, making the holes of the band coincide with the relevant locking spheres.

GEC - compact elastic coupling: technical data

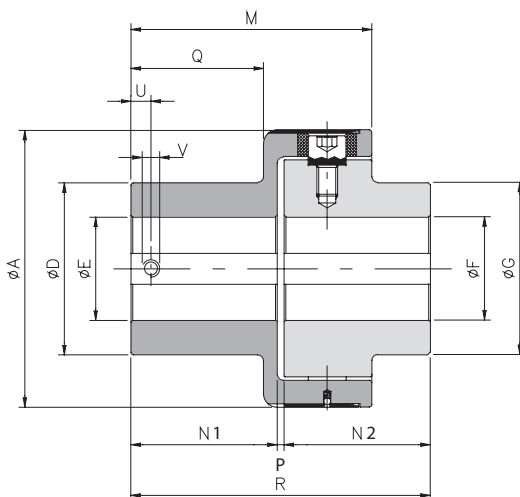

DIMENSIONS

Size	A	D	E H7		F H7		G	M	N1	N2	P	Q	R	U	V
			pilot	max	pilot	max									
00	63	42	-	28	-	24	42	52	24	25	2	18	52	8	M4
0	78	50	-	35	-	35	50	63,5	32	3,5	3,5	28	67,5	10	M5
1	108	70	-	48	-	48	70	89	49	4	4	44	102	12	M6
2	130	80	-	55	-	55	80	111	65	4	4	59	134	15	M8
3	161	100	-	68	-	68	100	140	85	4	4	77	174	15	M8
4	206	120	20	80	20	80	120	168	105	4	4	97	214	20	M10
5	239	135	30	90	30	90	135	201	130	4	4	120	264	20	M10
6	315	215	40	150	40	120	175	260	165	5	5	150	335	25	M12
7	364	240	40	165	40	145	210	310	205	5	5	185	415	25	M12
...	610	320	80	220	80	220	320						535		-

TECHNICAL CHARACTERISTICS

Size	Torque [Nm]		Weight [Kg]	Inertia [Kgm²]	Max speed [Rpm]	Operating temperature [°C]	Hardness elastic element [Sh-A]	Misalignments					
	nom	max						Angular α [°]		Axial X [mm]		Radial K [mm]	
								continuous	intermittent	continuous	intermittent	continuous	intermittent
00	35	50	0,8	0,00045	6000	-15 ÷ +150	74 ±3	1°	1° 30'	±0,7	± 1,5	0,5	0,7
0	70	110	1,5	0,00124	5500			1°	1° 30'	±0,7	± 1,5	0,5	0,7
1	280	420	4,2	0,00633	5000			0° 48'	1°	±0,7	± 1,5	0,5	0,7
2	570	860	7,7	0,01592	4500			0° 36'	0° 48'	±0,7	± 1,5	0,6	0,7
3	980	1500	14,2	0,04666	4000			0° 30'	0° 42'	±0,8	± 1,6	0,6	0,8
4	2340	3600	22,6	0,12546	3100			0° 24'	0° 30'	±0,8	± 1,6	0,6	0,8
5	3880	5800	36,0	0,26035	2800			0° 24'	0° 30'	±0,8	± 1,6	0,6	0,8
6	15000	20000	118	0,88951	2000			0° 24'	0° 30'	±0,8	± 1,6	0,6	0,8
7	30000	35000	128,4	1,77108	1500			0° 24'	0° 30'	±0,8	± 1,6	0,6	0,8
...	90000	105000											

ORDER EXAMPLE

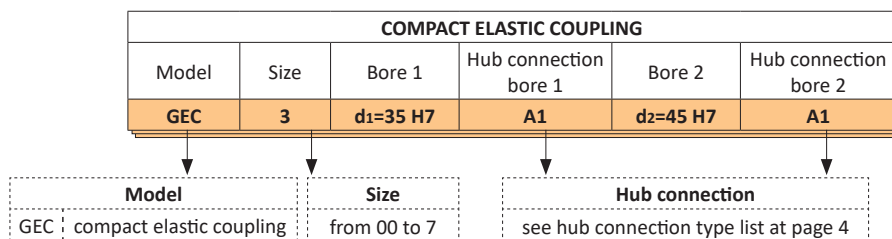

NOTES

▲ On request

- The weights refer to the coupling with minimum bore.
- Inertias refer to the coupling with maximum bore.
- Choice and availability of different hub connection type see pages 4 and 5.