



ComInTec[®]
Safety in Power Transmission

JAW COUPLING

up to 55 KNm and 200 mm bore diameters



Ed.04/2024

GAS/SG GAS



- Download catalog
- Download instruction sheets
- Download 3D and 2D cad model

GAS/SG-ST - backlash free jaw coupling «in steel»: introduction



- Made in steel fully turned with standard phosphating treatment.
- Several elastomer hardnesses available (see page 27).
- High torsional rigidity.
- Electric insulation between the parts.
- Statically balanced.
- Version with integrated locking assemblies (GAS/SG/CCE page 29).

ON REQUEST

- Conformity to directive ATEX possible.
- Specific surface treatments or fully stainless steel version (GAS-SS).
- Customised manufacturing for specific requirements.
- Connection to the Torque limiter's (safety coupling) range possible.



The coupling GAS/SG is an elastomeric coupling with compact dimensions composed of two hubs made in steel UNI EN ISO 683-1:2018, fully turned and one elastomeric element.

The hub's tooth profile is designed to allow the elastomeric element to work only by compression and not in shear, allowing for a longer life of the coupling in high reversal or load applications.

The presence of the elastomer assures:

- the possibility to absorb collisions and vibrations;
- to compensate for unavoidable misalignments between the shafts;
- silence during transmission.

The basic series of GAS/SG is composed of different details that can be assembled together in order to get the right configuration for the application:

- **Hub 1 (M1):** hub base for any type of connection
- **Long hub 1 (M1L):** extended hub for connecting long shafts
- **Hub 2 (M2) :** hub with external diameter lowered for assembly in confined spaces

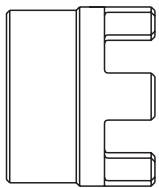

Hub M1

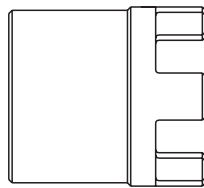

Hub M1L

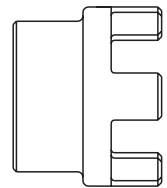

Hub M2

DESCRIPTION OF THE ELASTOMERIC ELEMENT

The fundamental item of this coupling is the elastomeric element or elastomer, made in polyurethane and available in several hardness grades, for different uses and applications. The elastomer is manufactured to resist ageing, scoring, fatigue, hydrolysis and UV radiations, promoting longer life operation. It also resists main chemical agents, like ozone, oils, grease and hydrocarbons.

The elastomeric element becomes prestressed during the assembly between the relevant hub's teeth, in order to be able to transmit the motion without backlash, so torsionally rigid inside the prestressing load. The prestressed elastomer's surface is sufficiently wide to induce a low contact pressure on the tooth of the same elastomer, reducing permanent deformations and promoting a long life.

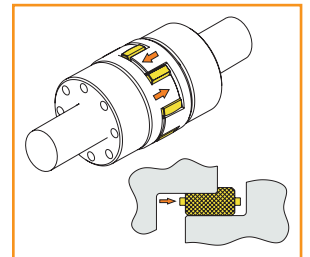

ATEX CONFORMITY

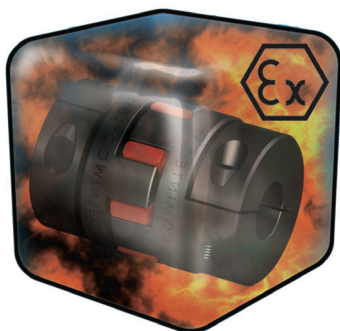

The GAS/SG coupling can be supplied in accordance to directive 2014/34/UE ATEX, which is relevant to protection apparatus and systems for use in potentially explosive spaces.

The dimensions of this coupling's version are not different from the standard version.



A mark relevant to the coupling's performances is printed on the hubs. It is necessary to consider planned tests, like those in the use and maintenance manual supplied together with each ATEX coupling.

The elastomeric elements used can be:

- yellow elastic element in polyurethane, 92 Shore-A : II 2 G D c T5 -20≤Ta≤+80°C X U
- red elastic element in polyurethane, 98 Shore-A : II 2 G D c T6 -20≤Ta≤+60°C X U
- green elastic element in polyurethane, 64 Shore-D : II 2 G D c T6 -20≤Ta≤+80°C X U

GAS/SG-ST - backlash free jaw coupling «in steel»: introduction

SG ELASTIC ELEMENT: PHYSICAL CHARACTERISTICS

Hardness	Material	Spider	Allowed temperature [°C]		Uses
			working	max (for short period)	
92 Sh-A	Polyurethane		-40 ÷ +90	-50 ÷ +120	- low and medium power - measurement and control system - common electric motors
98 Sh-A	Polyurethane		-30 ÷ +90	-40 ÷ +120	- high transmission torque - actuators, screwjacks - servomotors, right angle gearboxes
64 Sh-D	Polyurethane		-20 ÷ +110	-30 ÷ +120	- high torsional rigidity - machining centres - internal combustion motors

▲ On request different materials and hardnesses for specific applications

SG ELASTOMERIC ELEMENT: TECHNICAL CHARACTERISTICS

Size	Hardness	Torque		Misalignment			Rigidity			
		nom [Nm]	max [Nm]	angular α [°]	axial X [mm]		radial K [mm]	static torsional R_{stat} [Nm/Rad]	dynamic torsional R_{din} [Nm/rad]	radial R_r [N/mm]
					GAS/SG	-/DBSE				
◆ 04 (7)	● 92 Sh-A	1,2	2,4	1	+ 0,6	-	0,1	14,5	43	218
	98 Sh-A	2	4	0,9	- 0,3	-	0,06	23	69,5	420
◆ 03 (9)	92 Sh-A	3	6	1	+ 0,8	-	0,13	31,5	95	270
	98 Sh-A	5	10	0,9	- 0,4	-	0,08	51,5	155	520
◆ 02 (12)	92 Sh-A	5	10	1	+ 0,9	-	0,15	160	460	265
	98 Sh-A	9	18	0° 54'	- 0,4	-	0,10	320	700	840
	64 Sh-D	12	24	0° 48'	-	-	0,08	300	950	1050
01 (14)	92 Sh-A	7,5	15	1°	+ 1	+ 1	0,14	115	340	330
	98 Sh-A	12,5	25	0° 54'	- 0,5	- 1	0,09	170	510	605
	64 Sh-D	16	32	0° 48'	-	-	0,06	235	700	855
00 (19)	92 Sh-A	10	20	1°	+ 1,2	+ 1,2	0,10	815	1900	1250
	98 Sh-A	17	34	0° 54'	- 0,5	- 1	0,06	980	2340	2000
	64 Sh-D	21	42	0° 48'	-	-	0,04	1450	4450	2950
0 (24)	92 Sh-A	35	70	1°	+ 1,4	+ 1,4	0,14	2300	5120	1900
	98 Sh-A	60	120	0° 54'	- 0,5	- 1	0,10	3650	8100	2900
	64 Sh-D	75	150	0° 48'	-	-	0,07	4500	11500	4180
1 (28)	92 Sh-A	95	190	1°	+ 1,5	+ 1,5	0,15	3810	7280	2100
	98 Sh-A	160	320	0° 54'	- 0,7	- 1,4	0,11	4180	10700	3650
	64 Sh-D	200	400	0° 48'	-	-	0,08	7350	18500	4880
2 (38)	92 Sh-A	190	380	1°	+ 1,8	+ 1,8	0,16	5580	11950	2850
	98 Sh-A	325	650	0° 54'	- 0,7	- 1,4	0,12	8150	21850	5000
	64 Sh-D	405	810	0° 48'	-	-	0,09	9920	33600	6200
3 (42)	92 Sh-A	265	530	1°	+ 2	+ 2	0,18	9800	20400	4050
	98 Sh-A	450	900	0° 54'	- 1	- 2	0,15	15000	34000	5900
	64 Sh-D	560	1120	0° 48'	-	-	0,10	16000	71300	7570
4 (48)	92 Sh-A	310	620	1°	+ 2,1	+ 2,1	0,22	11500	22000	4400
	98 Sh-A	525	1050	0° 54'	- 1	- 2	0,16	16000	49000	6800
	64 Sh-D	655	1310	0° 48'	-	-	0,11	31000	100000	8900
5 (55)	92 Sh-A	410	820	1°	+ 2,2	-	0,24	12000	22500	3100
	98 Sh-A	685	1370	0° 54'	- 1	-	0,17	24200	62500	7150
	64 Sh-D	825	1650	0° 48'	-	-	0,12	42000	111000	9850
6 (65)	92 Sh-A	630	1260	1°	+ 2,6	-	0,25	24000	35000	6400
	98 Sh-A	900	1800	0° 54'	- 1	-	0,18	45000	65000	6650
	64 Sh-D	1100	2200	0° 48'	-	-	0,13	115000	180000	8800

◆ Only for GAS/SG-AL version (see page 35)

● Elastic element 92 Sh-A white colour

GAS/SG-ST - backlash free jaw coupling «in steel»: technical data

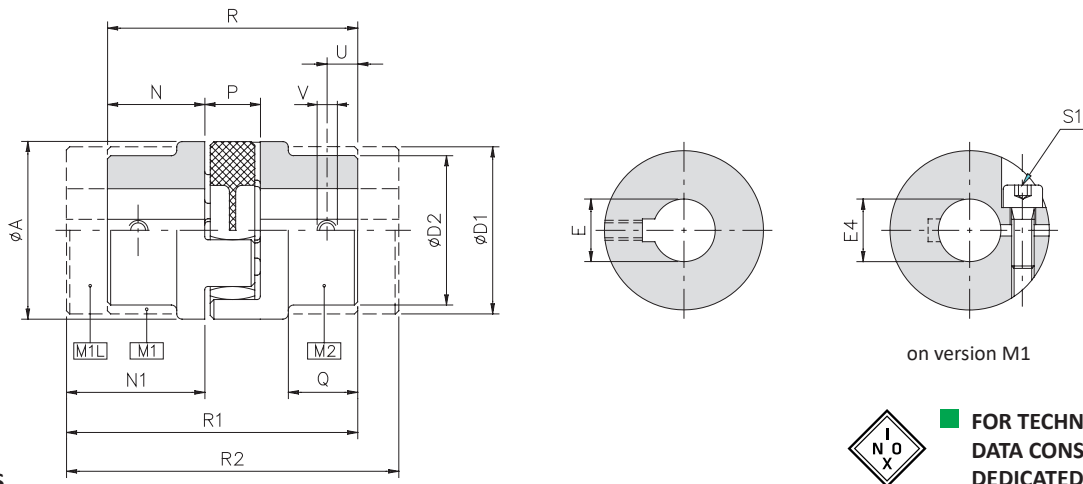

DIMENSIONS

Size	A	D1	D2	EH7 max		E4 H7 max		N	N1	P	Q	R	R1	R2	U	V
				M1/M1L	M2	min	max									
01 (14)	30	30	-	16	-	6	15	11	19	12	-	35	42.5	50	5	M4
00 (19)	40	40	32	25	20	8	20	25	37	16	16,5	66	78	90	10	M5
0 (24)	55	53	40	35	26	10	30	30	50	18	20	78	98	118	10	M5
1 (28)	65	63	48	40	32	14	35	35	60	20	24	90	115	140	15	M8
2 (38)	80	78	66	48	44	18	45	45	70	24	33	114	139	164	15	M8
3 (42)	95	93	75	55	50	20	50	50	75	26	38	126	151	176	20	M8
4 (48)	105	103	85	62	56	25	60	56	80	28	45	140	164	188	20	M8
5 (55)	120	118	98	74	65	32	65	65	90	30	49	160	185	210	20	M10
6 (65)	135	133	115	80	75	35	70	75	100	35	61	185	210	235	20	M10

TECHNICAL CHARACTERISTICS

Size	Torque [Nm]	Weight [Kg]				Inertia [kgm ²]				Max speed [Rpm]	Clamp hub	
		M1	M1L	M2	Spider	M1	M1L	M2	Spider		Screw S1	Tightening torque S1 [Nm]
01 (14)	See table of page 27	0,06	0,1	-	0,005	0,00001	0,00001	-	0,0000005	25000	M4	5
00 (19)		0,2	0,3	0,2	0,009	0,00005	0,00007	0,00003	0,0000015	19000	M5	10,5
0 (24)		0,4	0,8	0,3	0,020	0,00020	0,00029	0,00014	0,0000080	13500	M6	17,5
1 (28)		0,7	1,3	0,5	0,030	0,00042	0,00066	0,00027	0,0000180	11800	M8	28
2 (38)		1,3	2,2	1,1	0,060	0,00131	0,00189	0,00091	0,0000500	9500	M8	28
3 (42)		1,9	3,2	1,8	0,098	0,00292	0,00411	0,00178	0,0001000	8000	M10	84
4 (48)		2,8	4,4	2,4	0,105	0,00483	0,00653	0,00297	0,0002000	7100	M12	140
5 (55)		4,0	6,1	3,8	0,150	0,00825	0,01125	0,00505	0,0003000	6300	M12	140
6 (65)		5,9	8,6	4,6	0,200	0,01682	0,02175	0,01037	0,0005000	5600	M12	140

TORQUE PERMISSIBLE WITH HUB CONNECTION TYPE B

Size	Torque transmitted [Nm] according to the ϕ finished bore [mm]																												
	6	8	10	11	12	14	15	16	18	19	20	22	24	25	28	30	32	35	38	40	42	45	48	50	55	60	65	70	75
01 (14)	21	23	24	25	26	27	28	▲29																					
00 (19)		45	47	49	50	52	53	55	57	58	60																		
0 (24)			77	78	80	83	84	86	88	90	91	94	97	98	103	106													
1 (28)					158	161	164	169	171	174	179	184	187	194	199	204	212												
2 (38)								193	196	198	203	208	211	218	223	228	236	243	248	253	260								
▲ 3 (42)										342	350	357	361	372	379	387	398	409	417	424	435	446	454						
▲ 4 (48)													569	585	596	607	623	639	650	661	677	693	704	731	758				
▲ 5 (55)																672	688	704	715	726	742	758	769	796	823	850			
▲ 6 (65)																	753	769	780	791	807	823	834	861	888	915	942	970	

▲ on request

NOTES

- Clamps hub type B and B1 on size 01 machined with a single axial cut
- Clamps hub type C and C1 on size 01 machined on M1L hub (dimension N1)
- The weights refer to the coupling with minimum bore.
- Inertias refer to the coupling with maximum bore.
- For choice and availability of different hub connection type see pages 4 and 5.

GAS/SG/CCE-ST - backlash free jaw coupling with external locking assembly «in steel»: technical data

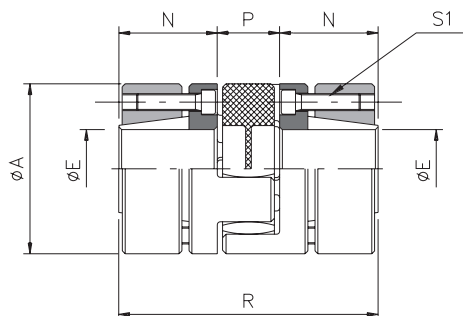

DIMENSIONS

Size	A	EH7		N	P	R
		min	max			
01 (14)	30	6	16	11,5	12	35
00 (19)	40	10	20	25	16	66
0 (24)	55	15	28	30	18	78
1 (28)	65	18	38	35	20	90
2 (38)	80	20	48	45	24	114
3 (42)	95	28	55	50	26	126
4 (48)	105	35	62	56	28	140
5 (55)	120	35	70	65	30	160
6 (65)	135	40	75	75	35	185

TECHNICAL CHARACTERISTICS

Size	Torque [Nm]	Weight [Kg]		Inertia [Kgm²]		Max speed [Rpm]	Clamp hub	
		M1	Spider	M1	Spider		Screw S1 UNI 5931	Tightening torque S1 [Nm]
01 (14)	See table of page 27	0,06	0,005	0,00001	0,0000005	25000	N°4 x M2,5	0,75
00 (19)		0,20	0,009	0,00005	0,0000030	19000	N°6 x M4	3
0 (24)		0,40	0,020	0,00020	0,0000100	13500	N°4 x M5	6
1 (28)		0,70	0,030	0,00042	0,0000200	11800	N°8 x M5	6
2 (38)		1,30	0,060	0,00131	0,0000500	9500	N°8 x M6	10
3 (42)		1,90	0,098	0,00292	0,0001000	8000	N°4 x M8	35
4 (48)		2,80	0,105	0,00483	0,0002000	7100	N°4 x M8	35
5 (55)		4,00	0,150	0,00825	0,0003000	6300	N°4 x M10	69
6 (65)		5,90	0,200	0,01682	0,0005000	5600	N°4 x M12	120

TORQUE PERMISSIBLE WITH EXTERNAL LOCKING ASSEMBLY TYPE D

Torque transmitted [Nm] according to the Ø finished bore [mm]																												
Grand.	6	10	11	14	15	16	17	18	19	20	22	24	25	28	30	32	35	38	40	42	45	48	50	55	60	65	70	75
01 (14)	7	12	13	17	18	20																						
00 (19)		48	53	67	72	77	81	86	91	96																		
0 (24)					77	82	88	93	98	103	113	124	129	144														
1 (28)								186	196	206	227	247	258	289	309	330	361	392										
2 (38)											291	320	349	364	408	437	466	510	553	582	612	655	699					
3 (42)														485	545	584	623	681	740	779	818	876	934	973	1071			
4 (48)															584	623	681	740	779	818	876	934	973	1071	1168			
5 (55)																1091	1184	1247	1309	1402	1496	1558	1714	1870	2026	2182		
6 (65)																		1852	1944	2083	2222	2315	2546	2778	3009	3241	3472	

NOTES

▲ on request

- The weights refer to the coupling with minimum bore.
- Inertias refer to the coupling with maximum bore.

GAS/SG-AL - backlash free jaw coupling «in aluminium»: technical data



- ⊙ Made in aluminum fully turned.
- ⊙ High torsional rigidity.
- ⊙ Elastomer available in different hardness (see page 27).
- ⊙ Weight and inertia reduced.
- ⊙ Electrical insulation between the parties.
- ⊙ Statically balanced.

ON REQUEST

- ⊙ Single split clamp hub with H7 bore and keyway (type B1).
- ⊙ Two piece clamp hub with H7 bore and keyway (type C1)
- ⊙ Conformity to Directive ATEX possible.
- ⊙ Customised manufacturing for specific requirements.

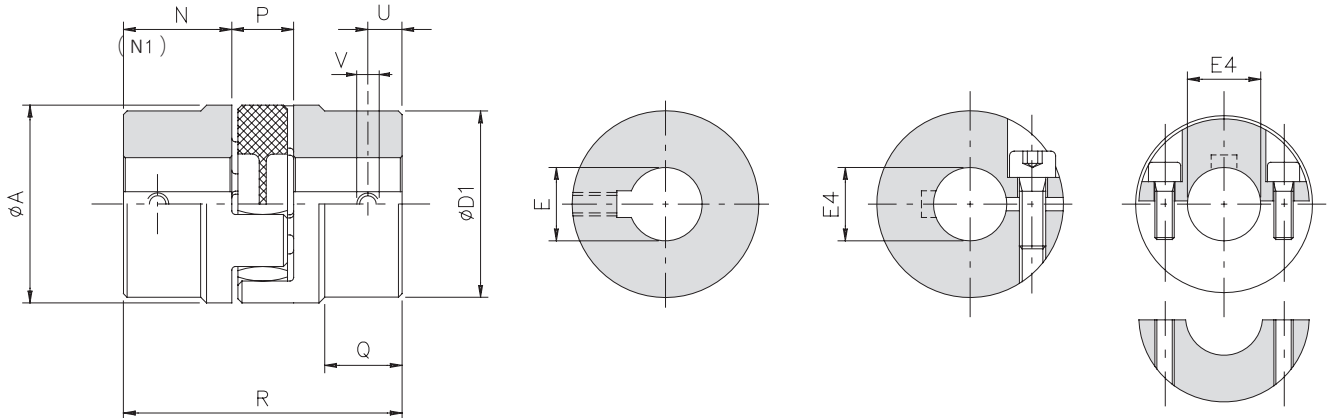

DIMENSIONS

Size	Torque [Nm]	A	D1	E H7 max	E4 H7		N	N1	P	Q	R	U	V	Weight [Kg]		Inertia [10 ³ kgm ²]		Max speed [Rpm]	Clamp hub	
					min	max								M1	Spider	M1	Spider		Screw	Tightening torque [Nm]
04 (7)	see table of pag.27	14	-	7	3	▲ 6	7	15	8	-	22	3,5	M3	0,003	0,0007	0,000085	0,000015	34000	M2,5	0,8
03 (9)		20	-	9	4	▲ 9	10	18	10	-	30	4	M4	0,009	0,002	0,000500	0,000080	22000	M3	1,4
▲ 02 (12)		25	-	12	5	12	11	19	12	-	34	5	M4	0,015	0,003	0,001500	0,000300	20000	M3	1,4
01 (14)		30	-	16	6	15	11,5	19	12	-	35	5	M4	0,02	0,005	0,002800	0,000500	19000	M4	3,1
00 (19)		40	-	25	8	20	25	-	16	-	66	10	M5	0,07	0,009	0,020500	0,001500	14000	M5	6,2
0 (24)		55	53	35	10	30	30	-	18	20	78	10	M5	0,13	0,020	0,050000	0,008000	10500	M6	10,5
1 (28)		65	63	40	14	35	35	-	20	24	90	15	M8	0,26	0,030	0,200000	0,018000	9000	M8	25
2 (38)		80	78	48	15	45	45	-	24	33	114	15	M8	0,46	0,060	0,400000	0,050000	7000	M8	25
▲ 3 (42)		95	93	62	20	50	50	-	26	38	126	20	M8	0,68	0,098	1,0420	0,1000	6000	M10	45
▲ 4 (48)		105	103	62	25	60	56	-	28	45	140	20	M8	1,00	0,105	1,7250	0,2000	5500	M12	80

TORQUE PERMISSIBLE WITH HUB CONNECTION TYPE B

Size	Torque transmitted [Nm] according to the ϕ finished bore [mm]																														
	3	4	5	6	8	9	10	11	12	14	15	16	18	19	20	22	24	25	28	30	32	35	38	40	42	45	48	50	55	60	
04 (7)	1,5	1,6	1,7	1,8																											
03 (9)		3,2	3,3	3,5	3,8	4,0																									
▲ 02 (12)			3,8	4,0	4,3	4,5	4,7	4,8	5,0																						
01 (14)				8,3	8,9	9,2	9,5	9,8	10,1	10,7	11,0	▲ 11,3																			
00 (19)					21	21	22	23	23	24	25	25	27	27	28	▲ 26	▲ 27														
0 (24)							35	35	36	37	38	39	40	41	41	42	44	44	46	48											
1 (28)										78	79	80	83	84	85	88	90	91	95	98	100	104	▲ 98								
2 (38)											94	95	98	99	100	103	105	106	110	113	115	119	123	125	128	131					
▲ 3 (42)															179	183	186	188	194	198	202	208	214	217	221	227	233	237			
▲ 4 (48)																		291	300	305	311	319	327	333	338	347	355	361	375	388	

NOTES

▲ On request

- ◆ Clamps hub type C and C1 on size 01, 02, 03, 04 machined on long hub M1L (dimension N1, change also total length R)
- Clamps hub type B and B1 on size 01, 02, 03, 04 machined with a single axial cut
- The weights refer to the coupling with minimum bore.
- Inertias refer to the coupling with maximum bore.
- For choice and availability of different hub connection type see pages 4 and 5.

GAS/SG/C-AL - COMPACT «aluminium» backlash free jaw coupling: technical data



- Compact solution
- Made in aluminium fully turned.
- Backlash free model for high torsional rigidity.
- Elastomer available in different hardness.
- Weight and inertia reduced.
- Electrical insulation between the parties.

ON REQUEST

- Single split clamp hub with H7 bore and keyway (type B1).
- Customised manufacturing for specific requirements.

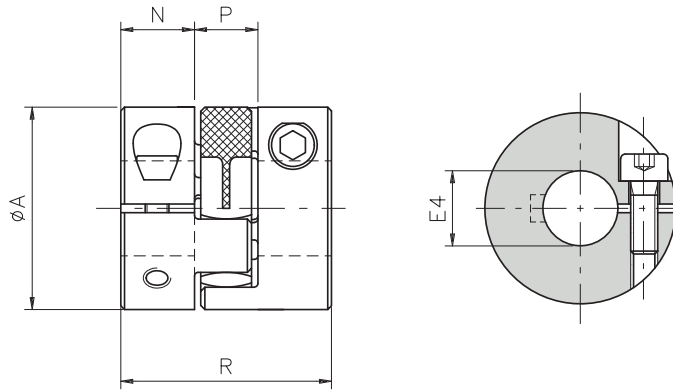

DIMENSIONS

Sizes	Nom. Torque [Nm] (*)			A	E4 H7		N	P	R	U1	Weight [Kg]		Inertia [$10^{-3} \text{Kg} \cdot \text{m}^2$]		Max speed [Rpm]	Clamp locking	
	92 Sh-A	98 Sh-A	64 Sh-D		min	max					M1	Jaw	M1	Jaw		Screw	Tightening torque [Nm]
▲ 04 (7)	1	2	-	14	3	6	5	8	18	2,5	0,002	0,0007	0,000065	0,000015	34000	M2,5	0,8
▲ 03 (9)	3	5	-	20	4	9	7	10	24	3,5	0,006	0,002	0,000375	0,000080	22000	M3	1,4
▲ 02 (12)	5	9	12	25	4	12	6,5	12	25	3,5	0,009	0,003	0,001035	0,000300	20000	M3	1,4
01 (14)	7,5	12,5	16	30	6	15	10	12	32	5	0,015	0,005	0,002478	0,000500	19000	M4	3,1
00 (19)	10	17	21	40	8	20	17	16	50	8	0,065	0,009	0,019483	0,001500	14000	M5	6,2
0 (24)	35	60	75	55	10	32	18	18	54	8	0,055	0,020	0,020908	0,008000	10500	M6	10,5
1 (28)	95	160	200	65	14	36	21	20	62	9	0,135	0,030	0,133790	0,018000	9000	M8	25
2 (38)	190	325	405	80	15	45	26	24	76	11	0,200	0,060	0,193815	0,050000	7000	M10	45
▲ 3 (42)	265	450	560	95	20	50	32	26	90	16	0,335	0,098	0,653572	0,100000	6000	M10	45
▲ 4 (48)	310	525	655	105	25	60	33	28	94	17	0,465	0,105	0,984324	0,200000	5500	M12	80

TRANSFERABLE TORQUE TYPE B CLAMP LOCKING

Transferable torque [Nm] with respect to the diam. of the finished hole [mm]																																						
Sizes	3	4	5	6	8	9	10	11	12	14	15	16	18	19	20	22	24	25	28	30	32	35	36	38	40	42	45	48	50	55	60							
▲ 04 (7)	1,5	1,6	1,7	1,8																																		
▲ 03 (9)		3,2	3,3	3,5	3,8	4,0																																
▲ 02 (12)			3,7	3,8	4,0	4,3	4,5	4,7	4,8	5,0																												
01 (14)				8,3	8,9	9,2	9,5	9,8	10,1	10,7	11,0	▲11,3																										
00 (19)					21	21	22	23	23	24	25	25	27	27	28	▲26	▲27																					
0 (24)							35	35	36	37	38	39	40	41	41	42	44	44	46	48	50																	
1 (28)										78	79	80	83	84	85	88	90	91	95	98	100	104	▲105															
2 (38)											150	152	156	158	160	164	168	170	176	180	184	190	192	196	200	204	210											
▲ 3 (42)																179	183	186	188	194	198	202	208	210	214	217	221	227	233	237								
▲ 4 (48)																			291	300	305	311	319	321	327	333	338	347	355	361	375	388						

▲ On request

N.B.

- The weight values refer to the unworked hole coupling.
- The inertia values refer to the maximum hole coupling.
- B and B1 locking activated with single axial cut.
- (*) For short periods: **Max. Torque = Nom. Torque x 2**

GAS/SG/DBSE-AL - backlash free jaw coupling with spacer «in aluminium»: technical data



- Made of aluminum fully turned.
- Elastomer available in different hardness (see page 27).
- Simple mounting thanks to the two piece clamp hub (type C).
- Radial assembly without removing the parts.
- Electrical insulation between the parts.
- Spacer with DBSE custom made.

ON REQUEST

- Two piece clamp hub with keyway (C1).
- Various hub connection types available.
- Conformity to Directive ATEX possible.
- Dynamic balancing up to Q=2.5.

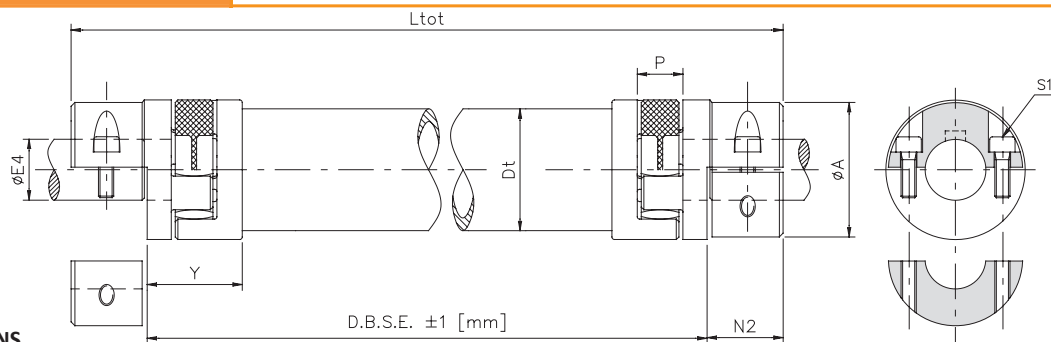

DIMENSIONS

Size	Torque [Nm]	A	E4 H7		N2	P	Y	Spacer			Total weight [Kg]	L _{tot} [mm]	DBSE min [mm]	Clamp hub	
			min	max				Dt	Weight [Kg/m]	Inertia [10 ³ Kg+m ² /m]				Rigidity R _{r,rel} [Nm/rad·m]	Screw S1
01 (14)	See table of pag.27	30	6	15	14	12	20,5	30	1,06	0,162	1552	= 2 • weight [GAS/SG-AL] + spacer weight • (DBSE - 2Y) = DBSE + 2 N2	58	M4	3,1
00 (19)		40	8	20	19	16	30,5	35	1,27	0,273	2650		95	M5	6,2
0 (24)		55	10	30	22	18	37,5	50	1,91	0,917	8800		113	M6	10,5
1 (28)		65	14	35	25	20	41	60	3,34	2,184	21150		131	M8	25
2 (38)		80	15	45	34	24	46	70	5,09	4,341	42400		161	M8	25
3 (42)		95	20	50	39	26	49	80	5,94	7,418	66850		170	M10	46
4 (48)		105	25	60	46	28	49	90	6,78	11,021	99300		170	M12	80

TORQUE PERMISSIBLE WITH HUB CONNECTION TYPE C

Size	Torque transmitted [Nm] according to the ϕ finished bore [mm]																										
	6	8	9	10	11	12	14	15	16	18	19	20	22	24	25	28	30	32	35	38	40	42	45	48	50	55	60
01 (14)	6	8	9	10	11	12	14	15	▲ 16																		
00 (19)		14	16	17	19	21	24	26	28	31	33	35	▲ 33	▲ 36													
0 (24)				20	22	24	28	30	32	36	38	40	44	48	50	57	61										
1 (28)						55	59	63	71	75	79	86	94	98	110	118	126	137	▲ 128								
2 (38)							59	63	71	75	79	86	94	98	110	118	126	137	149	157	165	177					
3 (42)												121	133	146	152	170	182	194	212	230	243	255	273	291	303		
4 (48)															217	243	260	277	303	329	346	364	390	416	433	476	520

PERMITTED SPEEDS

▲ on request

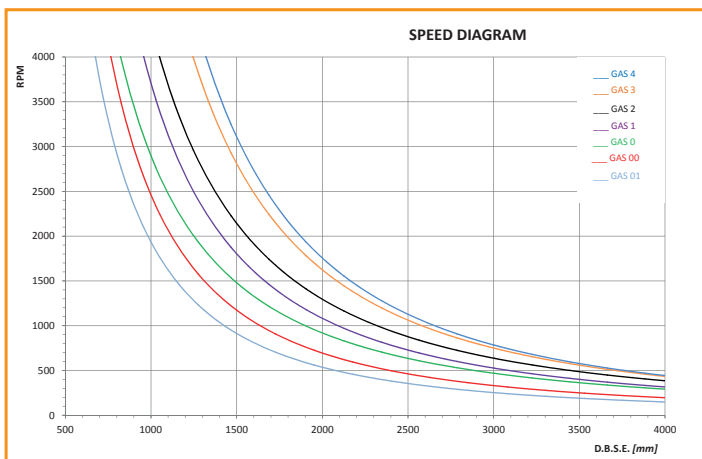

NOTES

- The weights refer to the coupling with minimum bore.
- Inertias refer to the coupling with maximum bore.
- For choice and availability of different hub connection type see pages 4 and 5.
- For high speed and/or distance to be connected, consult our technical department to evaluate the best connection solution (single spacer or split with central support, page 33)
- In case of vertical assembly, please contact our technical department.

GAS/SG/DBSE-AL - backlash free jaw coupling with spacer «in aluminium»: additional information

APPLICATION EXAMPLE

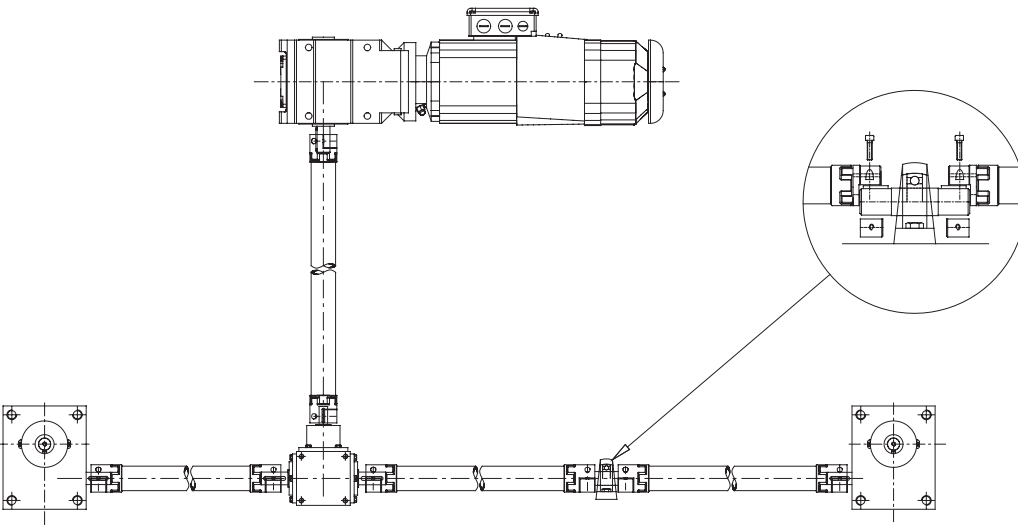

In case of a long DBSE combined with high speed, it is would be necessary to use an intermediate shaft with support and bearing. Please consult our Technical Department.

Plummer block housing units		
GAS/SG/DBSE	Type	Shaft
01	UCP 202	d=15
00	UCP 204	d=20
0	UCP 205	d=25
1	UCP 206	d=30
2	UCP 208	d=40
3	UCP 209	d=45
4	UCP 210	d=50

The model with a central spacer "GAS / SG / DBSE-AL", in addition to being essential for connecting transmission drives spaced apart. Is able (unlike the classic model GAS/SG) to recover, as needed, up to twice the angular misalignment (picture 2) and axial (picture 3) or a high radial misalignment (picture 1) according to the formula:

$$K = [L_{tot} - (2 \cdot N) - P] \cdot \text{Tg } \alpha$$

Where:

- K = radial misalignment [mm]
- L_{tot} = total length of GAS/DBSE coupling [mm]
- N = useful length of an half-hub [mm]
- P = useful space of the elastomeric element [mm]
- α = angular misalignment [°]

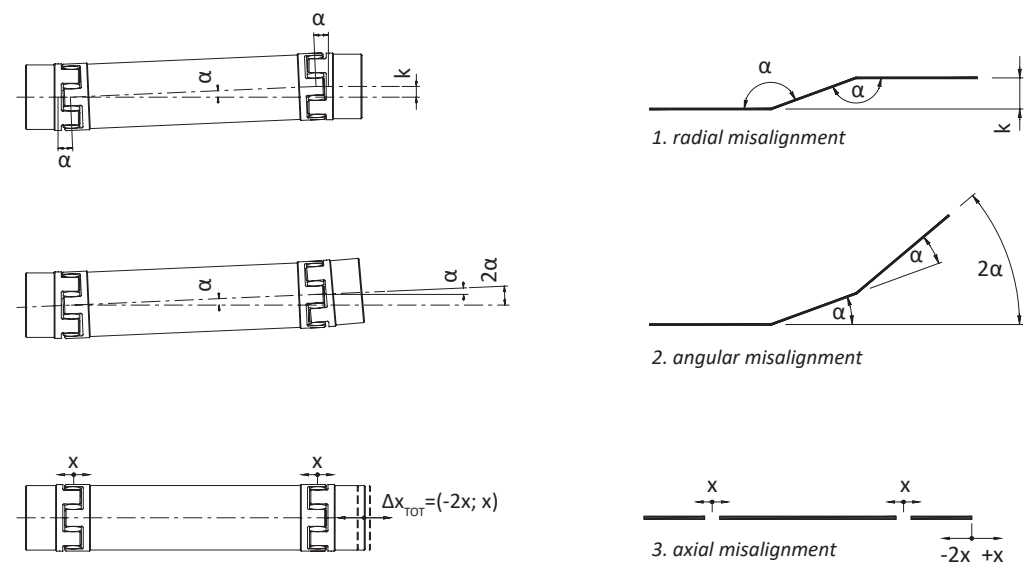

1. radial misalignment

2. angular misalignment

3. axial misalignment

It is possible to determine also the positioning error by the torsion angle according to the formula:

$$\beta = \frac{180 \cdot C_{mot}}{\pi \cdot R_{TOT}}$$

Where:

- β = torsion angle [°]
- C_{mot} = maximum torque motor side [Nm]
- R_{TOT} = total torsional rigidity of the coupling [Nm/rad]

In case of GAS/SG/DBSE-AL the total torsional rigidity of the coupling is expressed by the formula:

$$R_{TOT} = \frac{1}{\left(\frac{2}{R_T} + \frac{L_t}{R_{rel}}\right)}$$

Where:

- R_{TOT} = total torsional rigidity [Nm/rad]
- R_T = torsional rigidity of spider [Nm/rad]
- R_{rel} = torsional rigidity of spacer [Nm/rad]
- L_t = spacer length (=DBSE-2Y) [m]

GAS-ST - jaw coupling «in steel»: introduction



- Made in steel fully turned with standard phosphating treatment.
- Several elastomer hardnesses available (see page 35).
- High compensation of misalignments.
- Vibration dampening.
- Statically balanced.
- Modularity of the components, with different assembly versions.

ON REQUEST

- Conformity to ATEX directive possible.
- Specific treatments or version fully in stainless steel.
- Manufacturing made to length and customizations for specific needs.
- Connection to the Torque limiter's (safety coupling) range possible.



The coupling GAS/SG is an elastomeric coupling with compact dimensions composed of two hubs made in steel UNI EN ISO 683-1:2018, fully turned with one elastomer.

The hub's tooth profile is designed to allow the elastomeric element to work only by compression and not in shear, allowing for long life of the coupling in high reversal or load applications.

The GAS base series are available in several hub versions to allow an assembly to suit the application.

- **Hub 1 (M1)** : base hub for any kind of connection.
- **Long hub 1 (M1L)** : extended hub to connect long shafts.
- **Hub 2 (M2)** : hub with reduced external diameter for assembly in compact spaces.
- **Flangie (F)** : flange for connection shaft-flange.

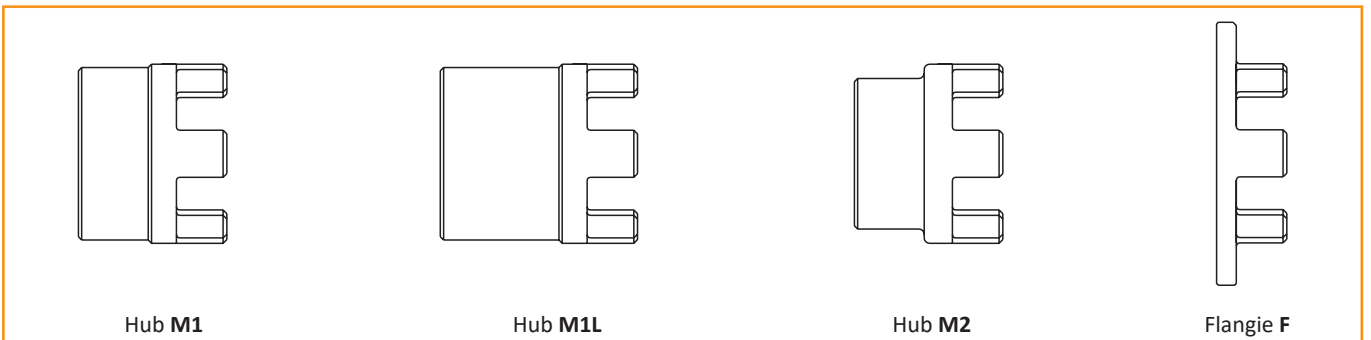

Hub M1

Hub M1L

Hub M2

Flangie F

DESCRIPTION OF THE ELASTOMERIC ELEMENT

The fundamental item of this coupling is the elastomeric element, made in different grades of hardness for different needs and applications. The elastomer is manufactured from elements to resist ageing, scoring, fatigue, hydrolysis and UV radiations, promoting long life operation and resisting main chemical agents, like ozone, oils, greases and hydrocarbons.

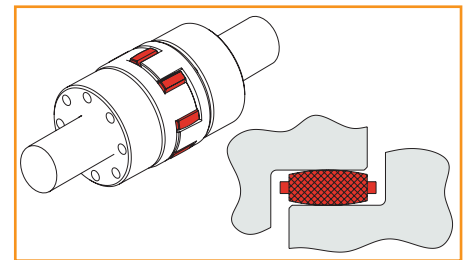

ATEX CONFORMITY



The GAS coupling can be supplied in accordance to directive 2014/34/UE (ATEX), which is relevant to protection apparatus and systems for use in potentially explosive spaces.

The dimensions of this coupling's version are not different from the standard version.



A mark relevant to the coupling's performances is printed on the hubs. It is necessary to consider planned tests, as described in the use and maintenance manual supplied together with each ATEX coupling.

The elastomeric elements used can be:

- yellow elastic element in polyurethane, 92 Shore-A : II 2 G D c T5 -20≤Ta≤+80°C X U
- green elastic element in polyurethane, 64 Shore-D : II 2 G D c T6 -20≤Ta≤+80°C X U

GAS-ST - jaw coupling «in steel»: introduction

ELASTIC ELEMENT: PHYSICAL CHARACTERISTICS

Hardness	Material	Spider	Allowed temperature [°C]		Users
			working	max (for short periods)	
92 Sh-A	Polyurethane		-40 ÷ +90	-50 ÷ +120	- low and medium power - systems with frequent starts
95 Sh-A	Polyurethane > size 8		-30 ÷ +90	-40 ÷ +120	- high transmission torque - high temperature range
98 Sh-A	Thermoplastic		-40 ÷ +80	-50 ÷ +110	
64 Sh-D	Polyurethane		-20 ÷ +110	-30 ÷ +120	- high torsional rigidity - Internal combustion motors

▲ On request different materials and hardnesses for specific applications

ELASTIC ELEMENT: TECHNICAL CHARACTERISTICS

Size	Hardness	Torque			Misalignments			Rigidity R_T [10^3 Nm/rad]			
		nom [Nm]	max [Nm]	alternate motion [Nm]	Angular α [°]	Axial x [mm]	Radial k [mm]	25% nom torque	50% nom torque	75% nom torque	100% nom torque
00 (19)	92 Sh-A	10	20	2,6	1° 18'	-0,5/+1,2	0,20	0,62	0,73	0,93	1,18
	98 Sh-A	17	34	4,4				0,92	1,14	1,33	1,49
	64 Sh-D	21	42	5,5				1,97	3,33	4,40	5,37
0 (24)	92 Sh-A	35	70	9	1° 18'	-0,5/+1,4	0,22	2,44	2,71	3,66	4,43
	98 Sh-A	60	120	16				3,64	4,74	5,47	5,92
	64 Sh-D	75	150	19,5				5,50	9,35	12,40	15,10
1 (28)	92 Sh-A	95	190	25	1° 18'	-0,7/1,5	0,25	4,10	5,73	6,62	7,65
	98 Sh-A	160	320	42				6,08	7,82	8,88	10,68
	64 Sh-D	200	400	52				10,10	17,00	22,55	27,50
2 (38)	92 Sh-A	190	380	49	1° 18'	-0,7/+1,8	0,28	8,69	10,75	12,55	14,57
	98 Sh-A	325	650	85				10,95	14,13	18,25	21,90
	64 Sh-D	405	810	105				25,75	43,50	57,50	70,10
3 (42)	92 Sh-A	265	530	69	1° 18'	-1/+2	0,32	11,52	14,66	17,27	21,50
	98 Sh-A	450	900	117				16,34	21,41	25,17	30,29
	64 Sh-D	560	1120	145				29,30	49,50	65,45	79,85
4 (48)	92 Sh-A	310	620	81	1° 18'	-1/+2,1	0,36	11,85	18,72	21,34	24,52
	98 Sh-A	525	1050	137				17,97	24,39	27,68	34,14
	64 Sh-D	655	1310	170				35,10	59,20	78,30	95,50
5 (55)	92 Sh-A	410	820	105	1° 18'	-1/2,2	0,38	16,63	26,27	29,94	34,42
	98 Sh-A	685	1370	178				24,88	33,77	38,33	47,27
	64 Sh-D	825	1650	215				39,65	66,90	88,55	107,90
6 (65)	92 Sh-A	625	1250	163	1° 18'	-1/+2,6	0,42	27,14	38,00	40,71	50,67
	98 Sh-A	940	1880	245				36,00	48,01	55,55	66,47
	64 Sh-D	1175	2350	305				55,54	93,65	124,00	150,10
7 (75)	92 Sh-A	1280	2560	335	1° 18'	-1,5/+3	0,48	54,17	70,10	89,38	103,63
	98 Sh-A	1465	2930	381				72,52	92,30	112,81	123,07
	64 Sh-D	2410	4820	625				91,21	153,87	203,51	249,12
8 (90)	92 Sh-A	2400	4800	624	1° 18'	-1,5/+3,4	0,50	88,99	113,90	164,29	177,98
	98 Sh-A	3600	7200	936				127,47	172,99	201,82	230,65
	64 Sh-D	4500	9000	1170				246,85	415,53	550,13	672,87
9 (100)	95 Sh-A	4900	9800	1280	1° 18'	-1,5/+3,8	0,52	95,09	157,88	210,55	255,82
10 (110)	95 Sh-A	7000	14000	1870	1° 18'	-2/+4,2	0,55	115,44	195,24	256,41	315,42
---	95 Sh-A	27500	55000	7200	-	-	-	-	-	-	-

▲ on request

GAS-ST - jaw coupling «in steel»: technical data

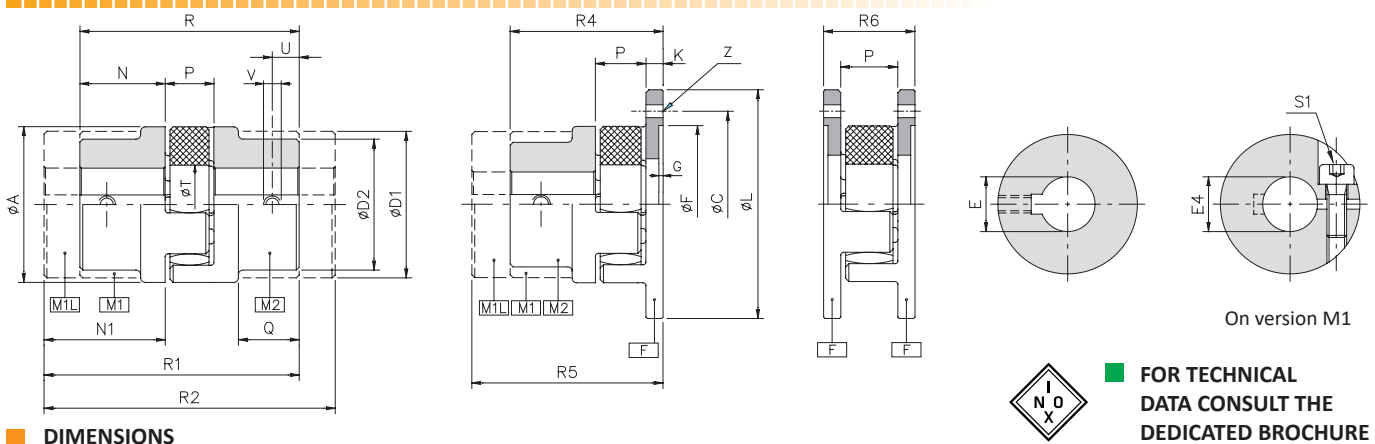

DIMENSIONS

FOR TECHNICAL DATA CONSULT THE DEDICATED BROCHURE

Size	A	C	D1	D2	E H7 max		E4 H7		F H7	G	L	K	N	N1	P	Q	R	R1	R2	R4	R5	R6	T	U	V	Z	
					M1/M1L	M2	min	max																			
00 (19)	40	50	40	32	25	20	8	20	40	1,5	58	8	25	37	16	16,5	66	78	90	49	61	32	18	10	M5	n.5 x Ø4,5	
0 (24)	55	65	53	40	35	26	10	30	55	1,5	74	8	30	50	18	20	78	98	118	56	76	34	27	10	M5	n.5 x Ø4,5	
1 (28)	65	80	63	48	40	32	14	35	65	1,5	92	10	35	60	20	24	90	115	140	65	90	40	30	15	M8	n.6 x Ø6,6	
2 (38)	80	95	78	66	48	44	18	45	80	1,5	107	10	45	70	24	33	114	139	164	79	104	44	38	15	M8	n.6 x Ø6,6	
3 (42)	95	115	93	75	55	50	20	50	95	2	132	12	50	75	26	38	126	151	176	88	113	50	46	20	M8	n.6 x Ø9	
4 (48)	105	125	103	85	62	56	25	60	105	2	142	12	56	80	28	45	140	164	188	96	120	52	51	20	M8	n.8 x Ø9	
5 (55)	120	145	118	98	74	65	32	65	120	2	164	16	65	90	30	49	160	185	210	111	136	62	60	20	M10	n.8 x Ø11	
6 (65)	135	160	133	115	80	75	35	70	135	2	179	16	75	100	35	61	185	210	235	126	151	67	68	20	M10	n.10 x Ø11	
7 (75)	160	185	158	135	95	90	-	-	160	2,5	208	19	85	110	40	69	210	235	260	144	169	78	80	25	M10	n.10 x Ø14	
8 (90)	200	225	180	160	110	110	-	-	200	3	246	20	100	125	45	81	245	270	295	165	190	85	100	30	M12	n.12 x Ø14	
9 (100)	225	250	-	180	-	120	-	-	225	4	285	25	110	-	50	89	270	-	-	185	-	100	113	30	M12	n.12 x Ø14	
10 (110)	255	290	-	185	-	130	-	-	255	4	330	26	120	-	55	96	295	-	-	201	-	157	127	35	M16	n.12 x Ø18	
...	420	-	-	-	-	200	-	-	-	-	-	-	195	-	-	-	475	-	-	-	-	-	-	-	-	-	-

TECHNICAL CHARACTERISTICS

Size	Torque [Nm]	Weight [Kg]					Inertia [Kg·m²]					Max speed [Rpm]	Clamp hub	
		M1	M1L	M2	F	Spider	M1	M1L	M2	F	Spider		Screw S1	Tightening torque S1 [Nm]
00 (19)	See table of page 33	0,2	0,3	0,2	0,1	0,009	0,00005	0,00007	0,00003	0,00007	0,000003	19000	M5	10,5
0 (24)		0,4	0,8	0,3	0,3	0,020	0,00020	0,00029	0,00010	0,00014	0,000010	13500	M6	17,5
1 (28)		0,7	1,3	0,5	0,6	0,030	0,00042	0,00066	0,00022	0,00044	0,000020	11800	M8	28
2 (38)		1,3	2,2	1,1	0,9	0,060	0,00131	0,00189	0,00089	0,00121	0,000050	9500	M8	28
3 (42)		1,9	3,2	1,8	1,6	0,098	0,00292	0,00411	0,00232	0,00246	0,000100	8000	M10	84
4 (48)		2,8	4,4	2,4	1,8	0,105	0,00483	0,00653	0,00383	0,00302	0,000200	7100	M12	140
5 (55)		4,0	6,1	3,8	3,0	0,150	0,00825	0,01125	0,00740	0,00740	0,000300	6300	M12	140
6 (65)		5,9	8,6	4,6	3,7	0,200	0,01682	0,02175	0,01087	0,01087	0,000500	5600	M12	140
7 (75)		9,1	13	7,2	5,2	0,380	0,03933	0,04915	0,02393	0,02333	0,002000	4750	-	-
8 (90)		17,0	22	12,5	8,3	0,650	0,10936	0,09293	0,08484	0,06036	0,004000	3750	-	-
9 (100)	-	-	25	10,5	0,850	-	-	0,11450	-	0,006000	3350	-	-	
10 (110)	-	-	32	18,0	1,250	-	-	0,20120	-	0,011000	3000	-	-	
...	-	-	-	-	-	-	-	-	-	-	1800	-	-	

TORQUE PERMISSIBLE WITH HUB CONNECTION TYPE B

Size	Torque transmitted [Nm] according to the Ø finished bore [mm]																													
	8	10	11	12	14	15	16	18	19	20	22	24	25	28	30	32	35	38	40	42	45	48	50	55	60	65	70	75		
00 (19)	45	47	49	50	52	53	55	57	58	60																				
0 (24)		77	78	80	83	84	86	88	90	91	94	97	98	103	106															
1 (28)					158	161	164	169	171	174	179	184	187	194	199	204	212													
2 (38)								193	196	198	203	208	211	218	223	228	236	243	248	253	260									
3 (42)											342	350	357	361	372	379	387	398	409	417	424	435	446	454						
4 (48)													569	585	596	607	623	639	650	661	677	693	704	731	758					
5 (55)																672	688	704	715	726	742	758	769	796	823	850				
6 (65)																	753	769	780	791	807	823	834	861	888	915	942	970		

NOTES

▲ On request

- The weights refer to the coupling with minimum bore. • Inertias refer to the coupling with maximum bore.
- For choice and availability of different hub connection type see pages 4 and 5.

GAS-AL - jaw coupling «in aluminium»: technical data



- ⊙ Made in aluminum fully turned.
- ⊙ Elastomer available in different hardness (see pages 35).
- ⊙ Weight and inertia reduced.
- ⊙ Electrical insulation between the parties.
- ⊙ Statically balanced.
- ⊙ Vibration dampening.

ON REQUEST

- ⊙ Single split clamp hub with H7 bore and keyway (type B1).
- ⊙ Two piece clamp hub with H7 bore and keyway (type C1)
- ⊙ Conformity to Directive ATEX possible.
- ⊙ Customised manufacturing for specific requirements.

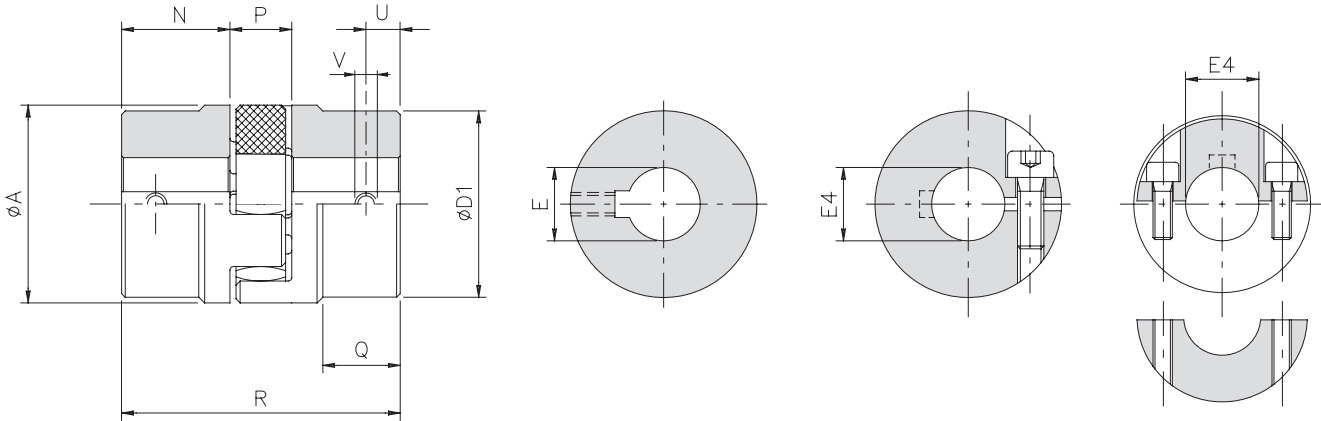

DIMENSIONS

Size	Torque [Nm]	A	D1	E H7 max	E4 H7		N	P	Q	R	U	V	Weight [kg]		Inertia [10 ⁻³ Kg ^m ²]		Max speed [Rpm]	Clamp hub	
					min	max							M1	Spider	M1	Spider		Screw	Tightening torque [Nm]
00 (19)	see table of pag.33	40	-	25	8	20	25	16	-	66	10	M5	0,07	0,009	0,020500	0,001500	14000	M5	6,2
0 (24)		55	53	35	10	30	30	18	20	78	10	M5	0,13	0,020	0,050000	0,008000	10500	M6	10,5
1 (28)		65	63	40	14	35	35	20	24	90	15	M8	0,26	0,030	0,200000	0,018000	9000	M8	25
2 (38)		80	78	48	15	45	45	24	33	114	15	M8	0,46	0,060	0,400000	0,050000	7000	M8	25
3 (42)		95	93	62	20	50	50	26	38	126	20	M8	0,68	0,098	1,0420	0,1000	6000	M10	45
4 (48)		105	103	62	25	60	56	28	45	140	20	M8	1,00	0,105	1,7250	0,2000	5500	M12	80

TORQUE PERMISSIBLE WITH HUB CONNECTION TYPE B

Size	Torque transmitted [Nm] according to the Ø finished bore [mm]																												
	8	9	10	11	12	14	15	16	18	19	20	22	24	25	28	30	32	35	38	40	42	45	48	50	55	60			
00 (19)	21	21	22	23	23	24	25	25	27	27	28	▲26	▲27																
0 (24)			35	35	36	37	38	39	40	41	41	42	44	44	46	48													
1 (28)						78	79	80	83	84	85	88	90	91	95	98	100	104	▲98										
2 (38)							94	95	98	99	100	103	105	106	110	113	115	119	123	125	128	131							
3 (42)											179	183	186	188	194	198	202	208	214	217	221	227	233	237					
4 (48)														291	300	305	311	319	327	333	338	347	355	361	375	388			

▲ On request

NOTES

- The weights refer to the coupling with minimum bore.
- Inertias refer to the coupling with maximum bore.
- For choice and availability of different hub connection type see pages 4 and 5.

GAS/SG & GAS - jaw coupling: additional information

APPLICATION EXAMPLE

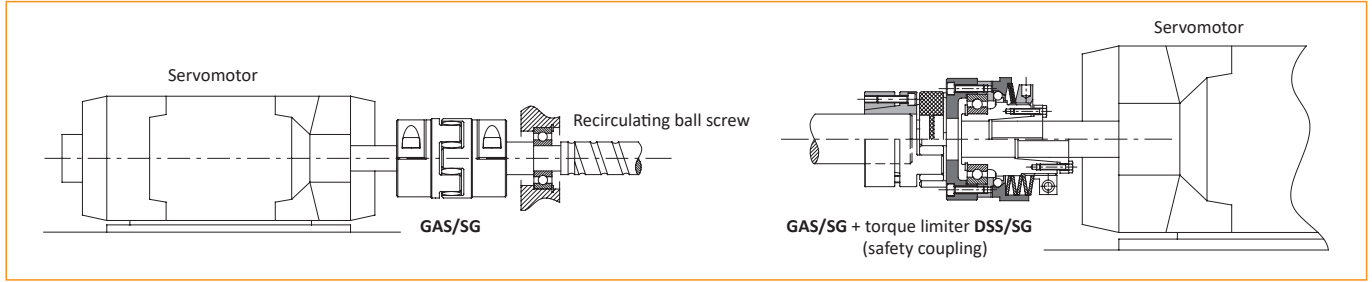

DIMENSIONING

For pre-selection of the coupling's size you can use the generic formula indicated on page 6. Having established the coupling's size to be used, it is possible to make other checks considering further parameters:

$$C_{nom} > C_{mot} \cdot f_T \cdot f_R$$

Dove:

- C_{nom} = theoretic nominal torque of the coupling [Nm]
- C_{mot} = nominal torque motor side [Nm]
- C_{max} = maximum torque of the coupling [Nm]
- C_{SU} = static torque user side [Nm]
- C_{SM} = static torque motor side [Nm]
- f_A = starting frequency factor
- f_R = rigidity factor
- f_T = thermic factor
- J_{mot} = inertia motor side [Kgm²]
- J_{uti} = inertia user side [Kgm²]
- K = shock factor

$$C_{max} = C_{SM} \cdot \frac{J_{uti}}{J_{mot} + J_{uti}} \cdot K \cdot f_T \cdot f_A + C_{mot} \cdot f_T \cdot f_R$$

$$C_{nom} = C_{SU} \cdot \frac{J_{uti}}{J_{mot} + J_{uti}} \cdot K \cdot f_T \cdot f_A + C_{mot} \cdot f_T \cdot f_R$$

$$C_{nom} > \frac{1}{M} \cdot C_{alt} \cdot f_F \cdot f_T \cdot f_R$$

Dove:

- C_{alt} = alternate system torque [Nm]
- C_{nom} = theoretic nominal torque of the coupling [Nm]
- f_F = resonance factor
- f_R = rigidity factor
- f_T = thermic factor
- M = coefficient of material

Coefficient of material (M)

0,25 = aluminium

0,35 = steel

Resonance factor (f_F)

1 = frequency < 10

$\sqrt{f/10}$ = frequency > 10

Rigidity factor (f_R)

2÷5 = positioning system

3÷8 = tool machines

>10 = turn indicator

Shock factor (K)

1 = light shock

1,4 = medium shock

1,8 = hard shock

Thermic factor (f_T)

1 = -30 ÷ +30 °C

1,2 = +40 °C

1,4 = +60 °C

1,8 = +80 °C

Starting frequency factor (f_A)

1 = 0 ÷ 100 starting each hour

1,2 = > 100 ÷ 200 " "

1,4 = > 200 ÷ 400 " "

1,6 = > 400 ÷ 800 " "

1,8 = > 800 ÷ 1600 " "

Completed and verified the choice of the coupling respect the torque to be transmitted, it is necessary to consider the flexibility, comparing the misalignment allowed by the type of coupling chosen with the real ones provided by the shafts to be connected. If simultaneously present at all types of misalignment, it is necessary that the sum as a percentage of the maximum value does not exceed 100%, according to the graphic 1.

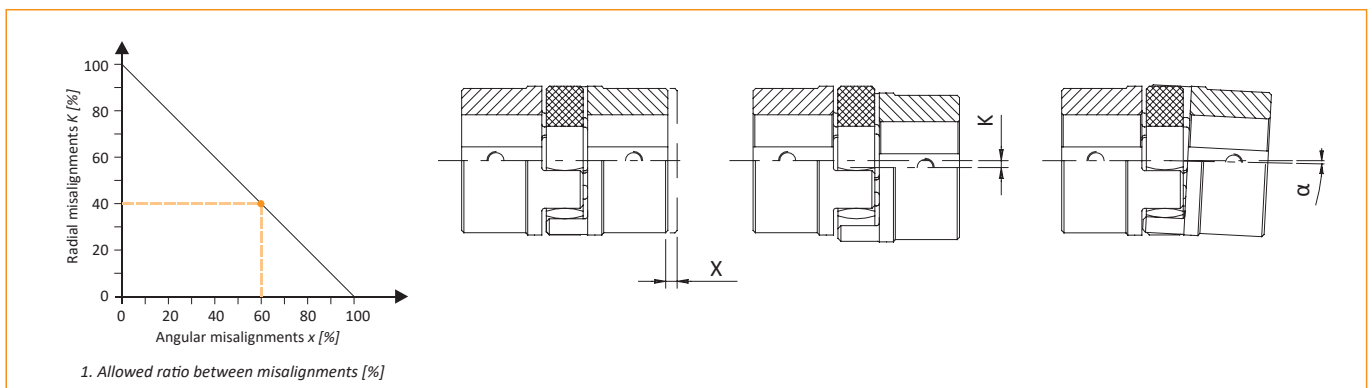

GAS/SG & GAS - jaw coupling: additional information

FITTING

This coupling does not require particular procedures for assembly. It can be assembled both vertically and horizontally.

- 1) Achieve radial and axial alignments as precisely as possible, in order to have maximum absorption of possible misalignments and life of the coupling.
- 2) Assemble the two half-hubs on the shafts. Check that the external parts of the two shafts do not exceed the relevant half-hub's surface (quote "N") and fix this one to the shaft with its relevant fixing system.
- 3) Assemble the elastomeric element on one half-hub and close the other inserting the relevant teeth into the elastomeric element, being careful to respect the distance of the two half-hubs indicated on the catalogue, quote "P".

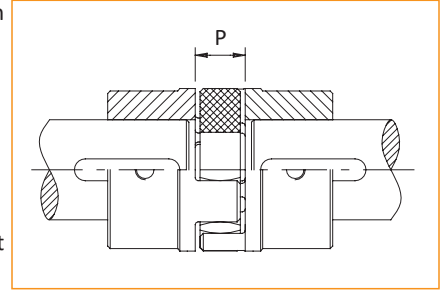

In case of connection by clamp locking or locking assemblies, tighten the relevant screws progressively up to the tightening torque indicated in the catalogue, using a cross sequence.

ORDER EXAMPLE OF COMPLETE COUPLING

JAW COUPLING									
Model	Material	Size	Version	Bore 1	Hub connection bore 1	Bore 2	Hub connection bore 2	● DBSE	Elastic element
GAS	ST	4	M1-M1	d1=40 H7	B1	d2=40 H7	B1	-	Red spider 98 Sh-A

Material	Size	Version	Hub connection	For GAS
ST steel	from 04 to 10	M1-M1	see hub connection type list at page 4	yellow spider 92 Sh-A
AL aluminium		M1-M1L		red spider 98 Sh-A
SS stainless steel		M1-M2		green spider 64 Sh-D
		M1-F		For GAS/SG - GAS/SG/DBSE
		M1L-M1		yellow spider SG 92 Sh-A
		M1L-M1L		red spider SG 98 Sh-A
		M1L-M2		green spider SG 64 Sh-D
		M1L-F		
		M2-M1		
		M2-M1L		
		M2-M2		
		M2-F		
		F-M1		
		F-M1L		
		F-M2		
		F-F		

Model	Elastic element
GAS	jaw coupling
GAS/SG	backlash free jaw coupling
▲ ● GAS/DBSE	jaw coupling with spacer
● GAS/SG/DBSE	backlash free jaw coupling with spacer

● In case of GAS/DBSE & GAS/SG/DBSE model indicate the length or spacer "DBSE".
Example DBSE = 250mm

▲ On request

ORDER EXAMPLE OF INDIVIDUAL COMPONENTS

INDIVIDUAL COMPONENTS OF JAW COUPLING				
Component	Material	Size	Bore H7	Hub connection
Hub GAS M1	ST	4	d=54 H7	C

Component	Material	Size	Hub connection
hub GAS M1	ST steel	from 04 to 10	see hub connection type list at page 4
hub GAS M1L	AL aluminium		
hub GAS M2	SS stainless steel		
flangie GAS F			
hub GAS/SG M1			
hub GAS/SG M1L			
hub GAS/SG M2			
yellow spider 92 Sh-A			
red spider 98 Sh-A			
green spider 64 Sh-D			
yellow spider SG 92 Sh-A			
red spider SG 98 Sh-A			
green spider SG 64 Sh-D			

GAS/SG & GAS - jaw coupling: selection for motors

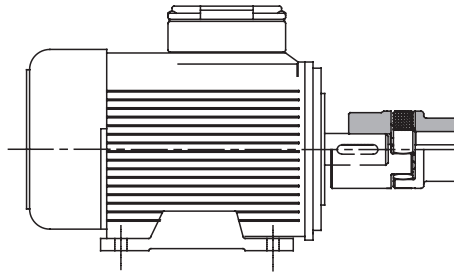

Electric motor		750 Rpm (8P)					1000 Rpm (6P)					1500 Rpm (4P)					3000 Rpm (2P)				
Size IEC	Shaft	P [Kw]	C [Nm]	GAS			P [Kw]	C [Nm]	GAS			P [Kw]	C [Nm]	GAS			P [Kw]	C [Nm]	GAS		
				92 Sh-A	98 Sh-A	64 Sh-D			92 Sh-A	98 Sh-A	64 Sh-D			92 Sh-A	98 Sh-A	64 Sh-D			92 Sh-A	98 Sh-A	64 Sh-D
56	Ø9x20	-	-	-	-	-	0,037	0,43	03	03	03	0,06	0,43	03	03	03	0,09	0,32	03	03	03
		-	-	-	-	-	0,045	0,52	03	03	03	0,09	0,64	03	03	03	0,12	0,41	03	03	03
63	Ø11x23	-	-	-	-	-	0,06	0,7	02	02	02	0,12	0,88	02	02	02	0,18	0,62	02	02	02
		-	-	-	-	-	0,09	1,1	02	02	02	0,18	1,30	02	02	02	0,25	0,86	02	02	02
71	Ø14x30	0,09	1,4	01	01	01	0,18	2,0	01	01	01	0,25	1,80	01	01	01	0,37	1,30	01	01	01
		0,12	1,8				0,25	2,8				0,37	2,50				0,55	1,90			
80	Ø19x40	0,18	2,5	00	00	00	0,37	3,9	00	00	00	0,55	3,70	00	00	00	0,75	2,50	00	00	00
		0,25	3,5				0,55	5,8				0,75	5,10				1,10	3,70			
90 S	Ø24x50	0,37	5,3	00	00	00	0,75	8,0	0	00	00	1,10	7,50	0	00	00	1,50	5,00	00	00	00
90 L	Ø24x50	0,55	7,9	0	00	00	1,10	12	0	0	0	1,50	10	00	00	00	2,20	7,40	0	00	00
100 L	Ø28x60	0,75	11	0	0	0	1,50	15	0	0	0	2,20	15	0	0	0	3,00	9,80	0	0	0
		1,10	16									3,00	20								
112 M	Ø28x60	1,50	21	0	0	0	2,20	22	0	0	0	4,00	27	1	0	0	4,00	13	0	0	0
132 S	Ø38x80	2,20	30	1	1	1	3,00	30	1	1	1	5,50	36	1	1	1	5,50	18	1	1	1
		-	-	-	-	-	-	-	-	-	-	-	-	-	-	-	-	7,50	25	-	-
132 M	Ø38x80	3,00	40	1	1	1	4,00	40	1	1	1	7,50	49	1	1	1	-	-	-	-	-
		-	-	-	-	-	5,50	55	1	1	1	-	-	-	-	-	-	-	-	-	-
160 M	Ø42x110	4,00	54	2	2	2	7,50	75	2	2	2	11,00	72	2	2	2	11,00	35	2	2	2
		5,50	74				7,50	109				11,00	15,00				15,00	19			
160 L	Ø42x110	7,50	100	2	2	2	11,00	109	2	2	2	15,00	98	2	2	2	18,50	60	2	2	2
180 M	Ø48x110	-	-	-	-	-	-	-	-	-	-	18,50	121	2	2	2	22	71	2	2	2
180 L	Ø48x110	11,00	145	3	2	2	15,00	148	3	2	2	22	148	3	2	2	-	-	-	-	-
200 L	Ø55x110	15,00	198	4	3	3	18,50	181	4	3	3	30	196	4	3	3	30	97	3	3	3
		-	-	-	-	-	22,00	215				37	120								
225 S	Ø55x110 Ø60x140	18,50	244	4	3	3	-	-	-	-	-	37	240	4	3	3	-	-	-	-	-
				4	4	4								4	4	4					
225 M	Ø55x110 Ø60x140	22	290	4	3	3	30	293	4	3	3	45	292	4	3	3	45	145	3	3	3
				4	4	4			4	4	4			3	4	4					
250 M	Ø60x140 Ø65x140	30	392	6	5	4	37	361	6	5	4	55	356	6	4	4	55	177	4	4	4
				6	5	5			6	5	5			5	5	5					
280 S	Ø65x140 Ø75x140	37	483	6	6	5	45	438	6	5	5	75	484	6	5	5	75	241	5	5	5
280 M	Ø65x140 Ø75x140	45	587	6	6	6	55	535	6	6	5	90	581	6	6	6	90	289	5	5	5
									6	6	6								5	6	6
315 S	Ø65x140 Ø80x170	55	712	8	7	6	75	727	8	7	6	110	707	8	7	6	110	353	6	5	5
									-	-	6						6	6			
315 M	Ø65x140 Ø80x170	75	971	8	7	7	90	873	8	7	7	132	849	8	7	7	132	423	7	6	5
									8	7	7						7	6	6		
315 L	Ø65x140 Ø80x170 Ø85x170	90	1170	8	8	7	110	1070	8	8	7	160	1030	8	8	7	160	513	7	6	5
		110	1420	8	8	8	132	1280	8	8	7	200	1290				200	641	7	6	6
		132	1710	10	8	8	160	1550	8	8	7	-	-				-	-	-	-	-
315	Ø65x140 Ø85x170	160	2070	10	8	8	200	1930	10	8	8	250	1600	8	8	7	250	802	8	7	7
		200	2580	-	10	8	250	2410	10	8	8	315	2020				8	315	1010	8	8
355	Ø75x140 Ø95x170	-	-	-	-	-	-	-	-	-	-	355	2280	9	8	8	355	1140	8	8	7
		250	3220	-	10	10	315	3040	-	10	8	400	2570	-	10	8	400	1280	8	8	7
		315	4060	-	-	-	400	3850	-	-	-	500	3210	-	10	10	500	1600	8	8	7
400	Ø80x170 Ø110x210	355	4570	-	-	-	450	4330	-	-	-	560	3580	-	-	-	560	1790	8	8	8
		400	5150	-	-	-	500	4810	-	-	-	630	4030	-	-	-	630	2020			

NOTES

◆ Only for GAS/SG-AL version (see page 30)

• For the choice of the coupling, is considered a safety factor of 1,5 on the nominal torque and an ambient temperature of 27 °C