

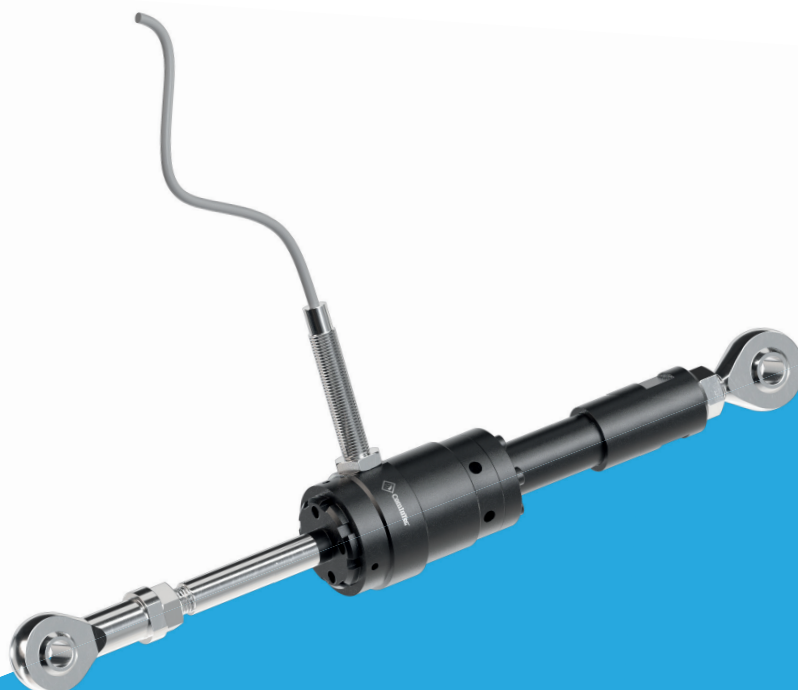

**ComInTec®**  
Safety in Power Transmission

# AXIAL FORCE LIMITER

up to 4,700 N and 20 mm shaft diameters



Ed.04/2024



- Download catalogue
- Download instruction sheets
- Download 3D and 2D cad model

# DSA

## DSA - axial force limiter: introduction

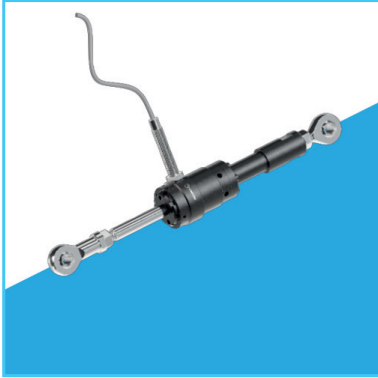

- ⦿ Axially backlash free.
  - ⦿ Protection in both tension and compression.
  - ⦿ Free movement in tension and compression after release.
  - ⦿ Automatic re-engagement in the exact position of disengagement.
  - ⦿ Innovative calibration system by “H dimension” for an immediate calibration of the device.
  - ⦿ Made of steel fully turned with special high mechanical strength.
  - ⦿ No maintenance for high reliability in the time.
- ON REQUEST
- ⦿ Complete with drive rods and rod ends.
  - ⦿ Sensor or switch mounted in axial or radial position.
  - ⦿ Possibility of customization for specific applications.
  - ⦿ Possibility of surface treatments for corrosion-specific needs.

Safety coupling with linear limitation of force. Releasing both in compressive and tension once it reaches the calibration force. The setting force can be adjusted by turning the adjuster nut onto the springs and re-engagement is automatic. Possibility of connecting linear motion also very distant from each other.

### ■ MAIN APPLICATIONS

- ⦿ Shaft mounted gearboxes.
- ⦿ Cam/Eccentric movements.
- ⦿ Transactions structured for pushers and slides.
- ⦿ Crank mechanism.

### ■ ADVANTAGES AND BENEFITS

- ⦿ Protect shaft mounted gearboxes overloads on the transmission.
- ⦿ Protect slides or other moving parts from accidental shock or collision limit.
- ⦿ Protect movements typically jams or improperly placements.
- ⦿ Protect the final product from crushing or deformation.

### ■ ASSEMBLY EXAMPLES

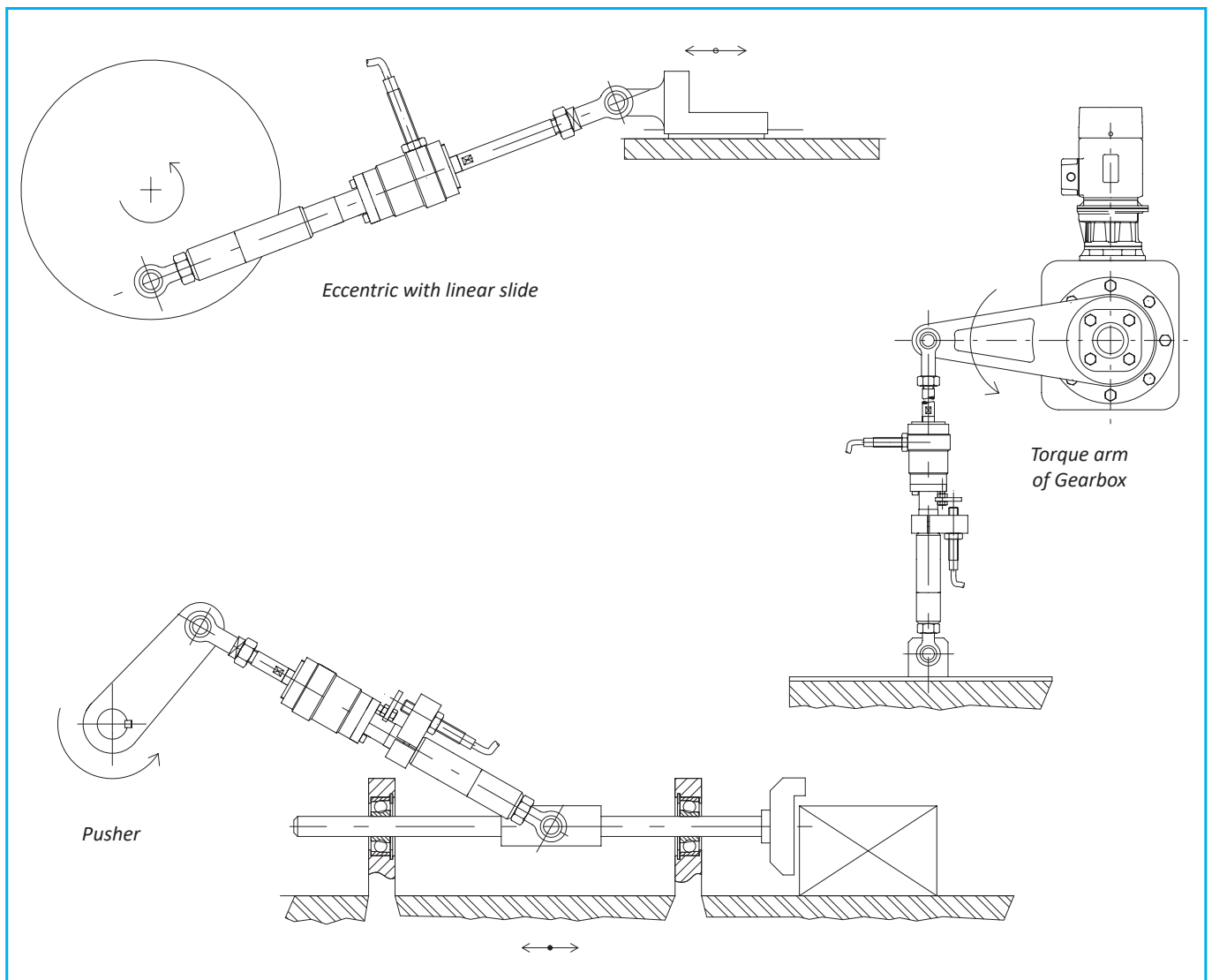

## DSA - axial force limiter: introduction



- High axial stiffness.
- Compact.
- Immediate interruption of power in case of overload.
- Continuous adjustment of the intervention force.
- Possibility of mechanical limit to prevent the slipping of the central pin after disengagement.
- Force range: 25-4.700 N.

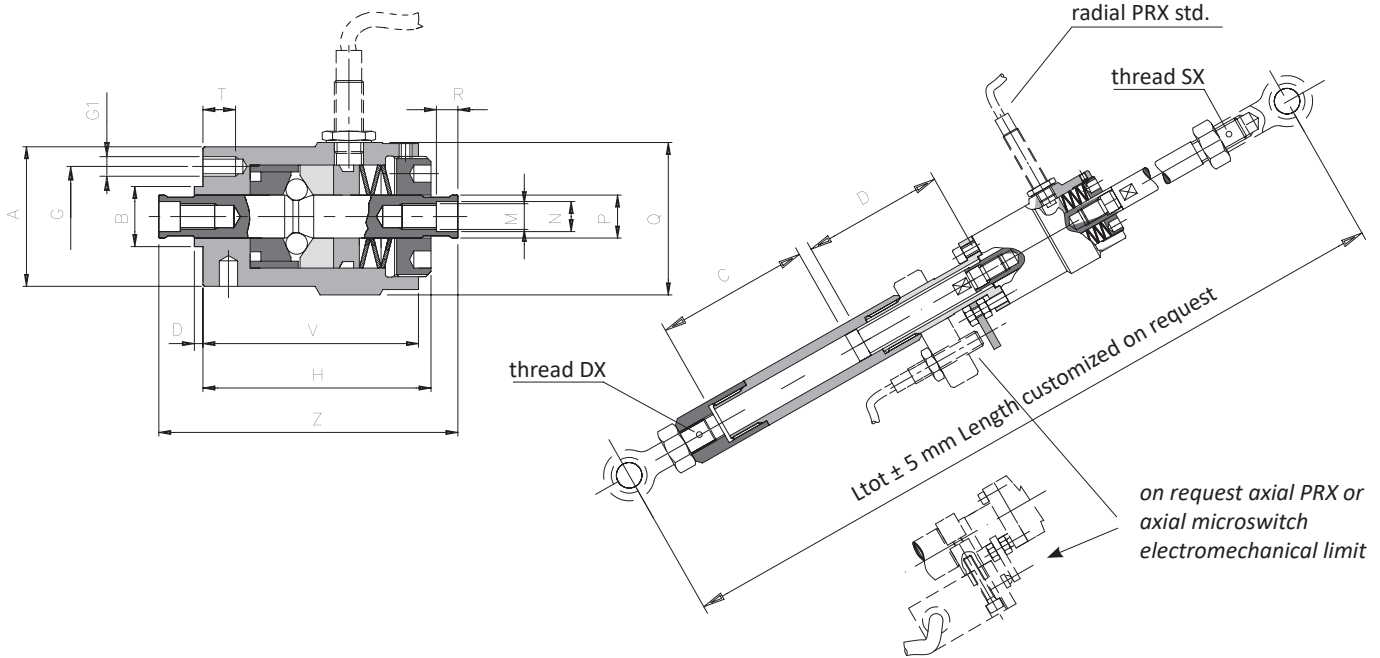

### DIMENSIONS AND TECHNICAL DETAILS

Size	Force [N]			A	B h7	E	G	G1	M	N h7	P	Q	R	T	V	Z	Weight [Kg]
	T0	T1	T2														
1	25 - 90	55 - 500	295 - 1300	30,5	14	2	22	6xM3	M6x0,75	7	10	36,5	5	7	50	66	0,3
2	-	320 - 1050	880 - 2850	38	18	2	28	6xM5	M10x0,75	11	14	42	9	10	61	85	0,5
3	-	530 - 2430	970 - 4700	50	25	3	37	6xM6	M12x1	13	20	56	10	11	78	105	1,1

## PRX - inductive proximity sensor: technical data



- Standard version: Stainless steel cover with protection level IP67 DIN 40050.
- Electric contact: 7 ÷ 30 Vdc. - Frequency: 4 KHz; Absorption ≤ 10 mA (Max 200mA).
- Operation temperature range from -25°C to + 70°C
- Output: NPN (N.O.-N.C.) – PNP (N.O.-N.C.).
- Operating distance: max 1,5 mm.
- Cable length: 2 m (3x0,2).

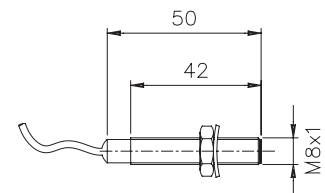
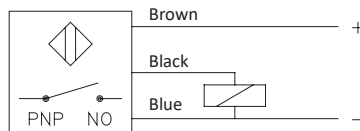
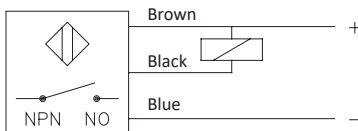

Weight: 50g

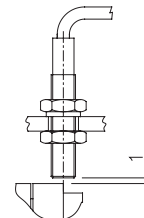
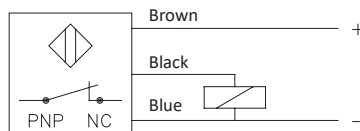
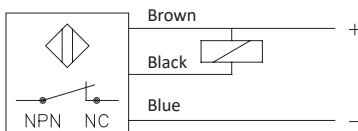

# DSA - axial force limiter: additional information

## ORDER EXAMPLE MODULE ONLY

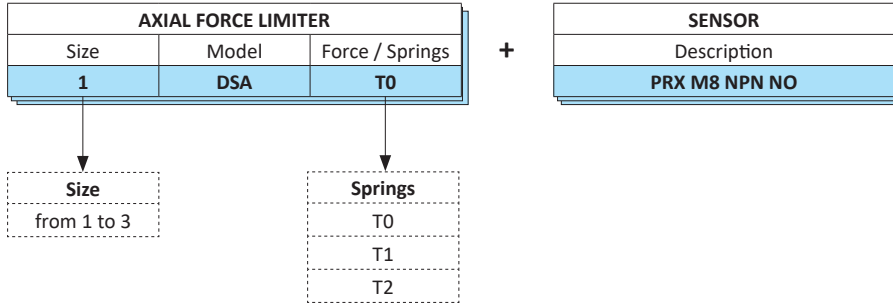

## ORDER EXAMPLE COMPLETE GROUP

