



ComInTec®
Safety in Power Transmission

MODULAR TORQUE LIMITER

up to 120 kNm and 260 mm bore diameters



Ed.04/2024



- Download catalogue
- Download instruction sheets
- Download 3D and 2D cad model

DSM

DSM - modular torque limiter (free rotation): introduction



- ⊙ Made in steel fully turned, with high mechanical strength.
 - ⊙ Free rotation after disengagement without residual torque.
 - ⊙ Reliable and maintenance free.
 - ⊙ Protected from external agents.
 - ⊙ Suitable for high rotation speeds and high inertias.
 - ⊙ Simple system of calibration and re-engagement.
 - ⊙ Compact and robust design.
- ON REQUEST
- ⊙ Overload signal ring (.../SI).
 - ⊙ Possibility of fitting with finished bore and keyway or locking assembly.
 - ⊙ Custom solutions for specific applications.
 - ⊙ Possibility of surface anticorrosive treatments for specific requirements.

A robust torque limiter with modular torque adjustment. Free rotation after overload permits high rotational speeds with also high torque settings and large shaft diameters can be accommodated.



The torque modules can be individually adjusted and re-engagement of the unit is quick and easy.

MAIN APPLICATION

- ⊙ Extruders and mills.
- ⊙ Mining industry and transporters.
- ⊙ Heavy industry.
- ⊙ Earthmoving machines and shredding/crushing machines.

ADVANTAGES AND BENEFITS

- ⊙ Product protection in case of overload.
- ⊙ Protection of operating units of machines in case of a collision.
- ⊙ Protection of the drive from external overloads.
- ⊙ Protecting conveyor belt stoppages.

	DSM: basic model for transmission to parallel shafts with plate wheel, gear or pulleys.	From 200 to 9,500 Nm of torque 140 mm max. bore	Pag. 47
	... + GAS: coaxial connection with elastic coupling to absorb start-up torque and vibration.	From 200 to 7.000 Nm of torque 140 mm max. bore	Pag. 48
	... + GTR: coaxial connection with torsionally rigid disc coupling for backlash free transmission.	From 200 to 9,500 Nm of torque 140 mm max. bore	Pag. 48

ESEMPI DI APPLICAZIONE

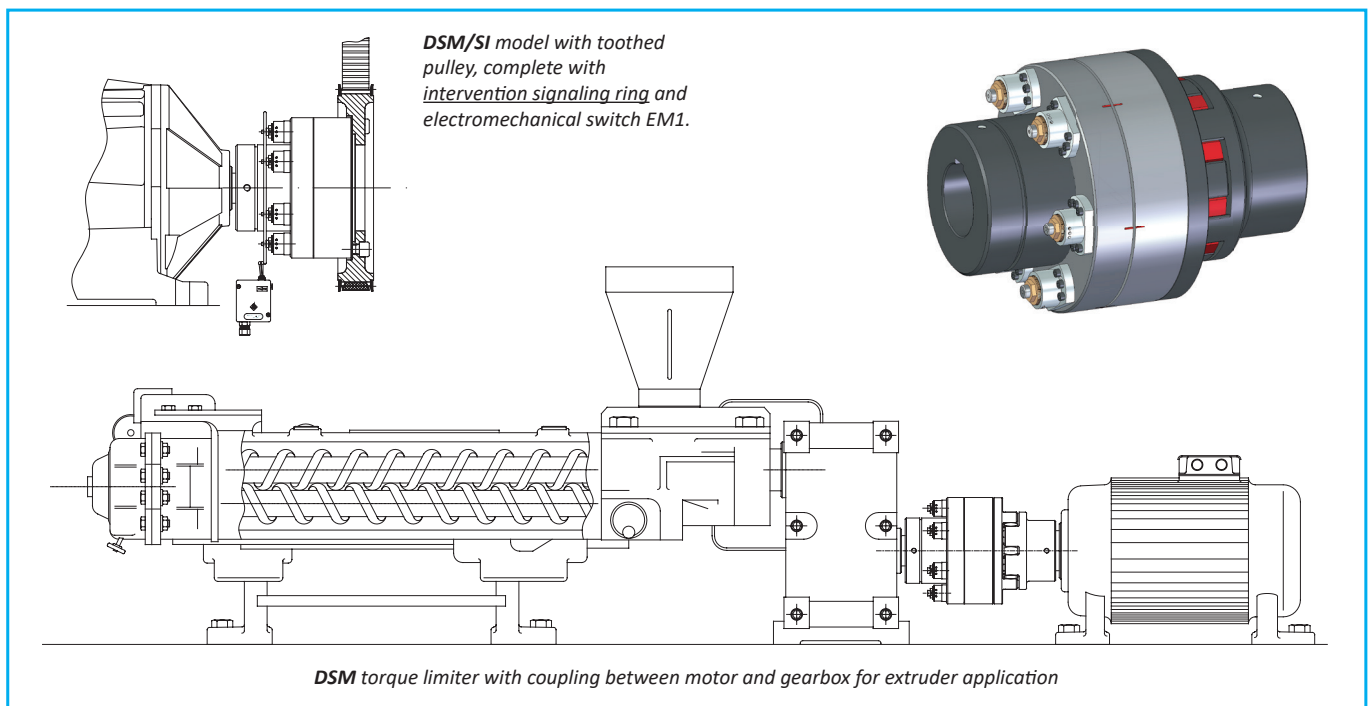

DSM - modular torque limiter (free rotation): technical data



- ⦿ Statically balanced with modules arranged symmetrically.
- ⦿ Torsionally rigid.
- ⦿ Module replacement without removing the device or other transmission components.
- ⦿ Complete separation between the driven and driving part after disengagement.
- ⦿ Integrated bearings for the support of the transmission.
- ⦿ Torque range: max up to 120 KNm; maximum ϕ 260 mm

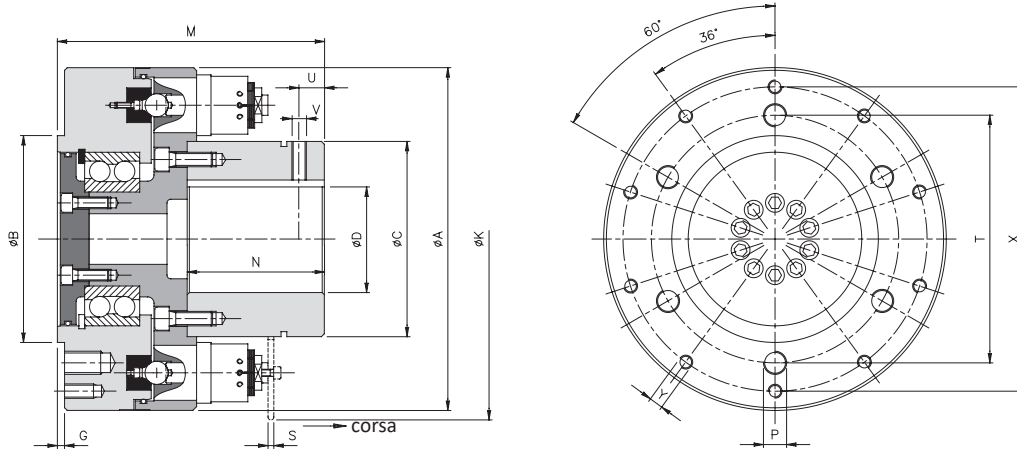

DIMENSIONS

Size	A	B h7	C	D H7 max	G	M	N	P	T	U	V	X	Y	On request	
														K	S
0	237	140	135	90	5	190	95	6xM16	170	18	M10	210	10xM10	250	4
1	270	175	165	110	5	220	110	6xM18	205	25	M12	245	10xM12	300	5
2	350	220	215	140	5	300	145	6xM20	260	35	M16	310	10xM14	380	6
...	650	-	-	260	-	485	-	-	-	-	-	-	-	-	-

CARATTERISTICHE TECNICHE

Size	Torque [Nm]			Stroke [mm]	Inertia [Kgm ²]		Max speed [Rpm]	Weight [Kg]
	3 MD	6 MD	9 MD		Flange side	Hub side		
0	200 - 1200	400 - 2400	-	4	0,136228	0,103605	3000	42
1	325 - 1400	650 - 2800	975 - 4200	4	0,284825	0,193814	3000	55
2	1250 - 3300	2200 - 6200	3300 - 9500	5,5	1,128794	0,807608	3000	85
...	Up to 120.000 Nm			-	-	-	-	-

NOTES

▲ On request

- The weights and inertias refer to the torque limiter with maximum bore and 6 modules.
- Microswitches EM1 and inductive sensor PRX see page 69

... + GAS - model with jaw coupling: technical data

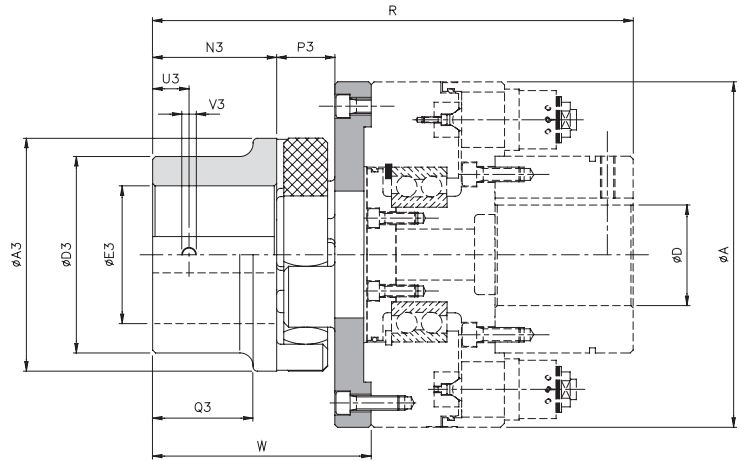

DIMENSIONS AND TECHNICAL CHARACTERISTICS

DSM	Size		Torque [Nm]		A3	D3	E3 H7 max	N3	P3	Q3	U3	V3	A	D H7 max	R	W	Misalignments			Speed [Rpm]	Weight [Kg]
	GAS std	GAS ▲	Nom	Max													Angular α [°]	Axial X [mm]	Radial K [mm]		
0	7	8	1465	2930	160	135	95	85	40	69	25	M10	237	90	335	150	1° 18'	2,5	0,48	3000	10
1	8	10	3600	7200	200	160	110	100	45	81	30	M12	270	110	385	170	1° 18'	2,8	0,50	3000	15
▲ 2	10	-	7000	14000	255	185	130	120	55	96	30	M12	350	140	500	205	1° 18'	3,2	0,55	3000	46

▲ On request

... + GTR - model with torsional rigid coupling: technical data

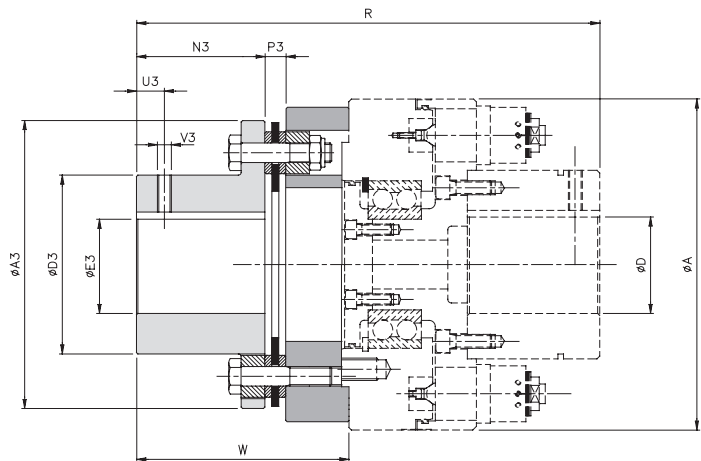

DIMENSIONS AND TECHNICAL CHARACTERISTICS

DSM	Size		Torque [Nm]		A3	D3	E3 H7 max	N3	P3	U3	V3	A	D H7 max	R	W	Misalignments			Speed [Rpm]	Weight [Kg]
	GTR	Nom	Max	Angular α [°]												Axial X [mm]	Radial K [mm]			
0	7	2600	5200	206	128	90	92	15	20	M10	237	90	337	152	0° 45'	2,2	-	3000	18	
1	8	4000	8000	226	133	95	100	22	20	M10	270	110	390	175	0° 45'	2,4	-	3000	29	
▲ 2	10	10000	20000	296	170	120	120	32	25	M12	350	140	535	240	0° 45'	2,6	-	3000	51	

NOTES

▲ On request

- ... + GAS: data relates to red normal elastomeric element 98 Sh-A (95 Shore-A for size 10).
- Data is relevant only to application (GAS, GTR), for torque limiter data see on page 47.
- Weights are relevant only to the coupling (GAS, GTR) with max bore.
- Microswitches EM1 and inductive sensor PRX see page 69

MD - module of calibration: technical data



- ⦿ Made in steel fully turned with high mechanical resistance.
- ⦿ Ease of registration.
- ⦿ Ease of manual re-engagement.
- ⦿ Mounted on DSM devices for a torsionally rigid transmission.
- ⦿ Disengaging with complete detachment between the driving and driven side.
- ⦿ Available in two sizes.

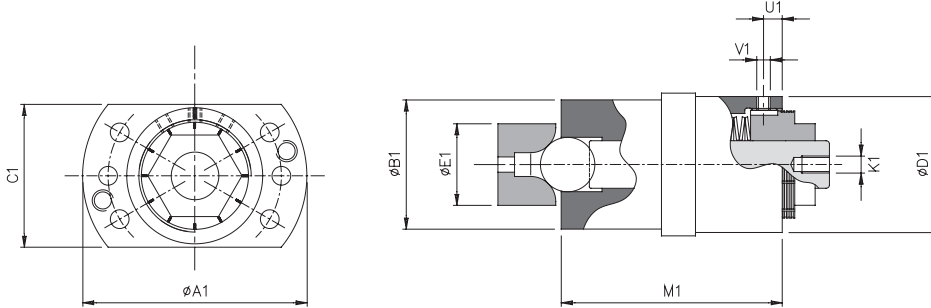

DIMENSIONS

Size		A1	B1 h7	C1	D1	E1 h7	K1	M1	U1	V1
DSM	MD									
0	2	66	38	42	40	24	M5	65	5,5	3xM4
1										
2	3	87	50	56	54	30	M8	95	5,5	3xM4

CALIBRATION

The key elements of the DSM module consist of the central piston (p) that will drive a hardened ball (s) into the location seat (t). Torque adjustment can be made also whilst the module is fitted to the torque limiter by the rotation of the hexagonal adjuster nut (r). Make sure that during the adjustment the fixing screw (u) is fully unscrewed to allow free rotation of the adjuster nut. The units are supplied as standard with the minimum possible torque setting but by rotating the adjuster nut clockwise the torque value will increase, and the setting can be monitored by viewing the adjustment notches located on the circumference of the adjuster nut. A complete revolution of the adjuster nut will equal one pitch. It is important once setting is completed to tighten the locking screw (u) in order to lock the adjuster nut in place. For more detailed setting instructions please see the fitting and setting instructions sheets available.

Calibration of a module

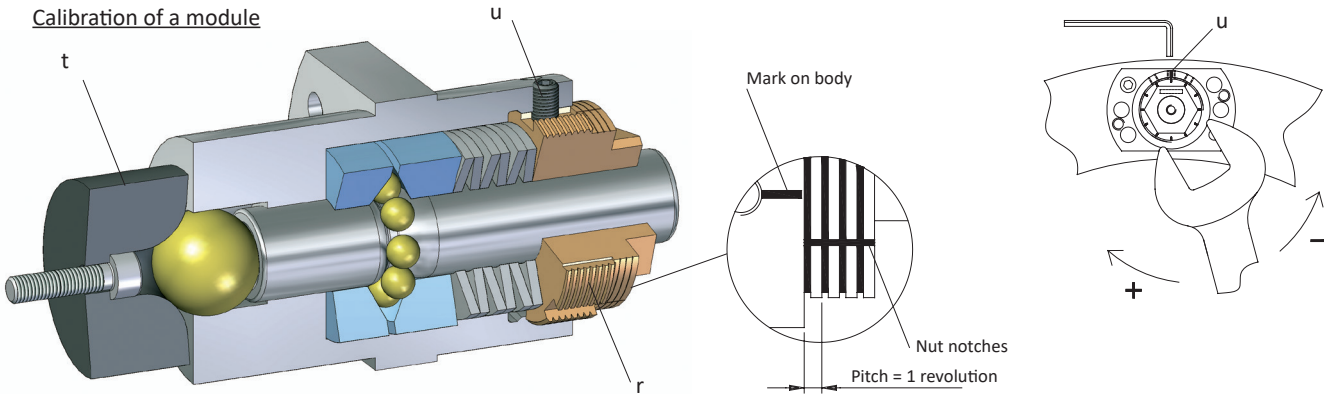

RE-ENGAGEMENT

The re-engagement of the limiter is manual and should only be performed with the device at rest. Turn the fixed base (c) or the mobile base (d) so that the two reference marks are in line. At this point, insert the pins of the related modules with slight but firm pressure using a tool or rubber mallet.

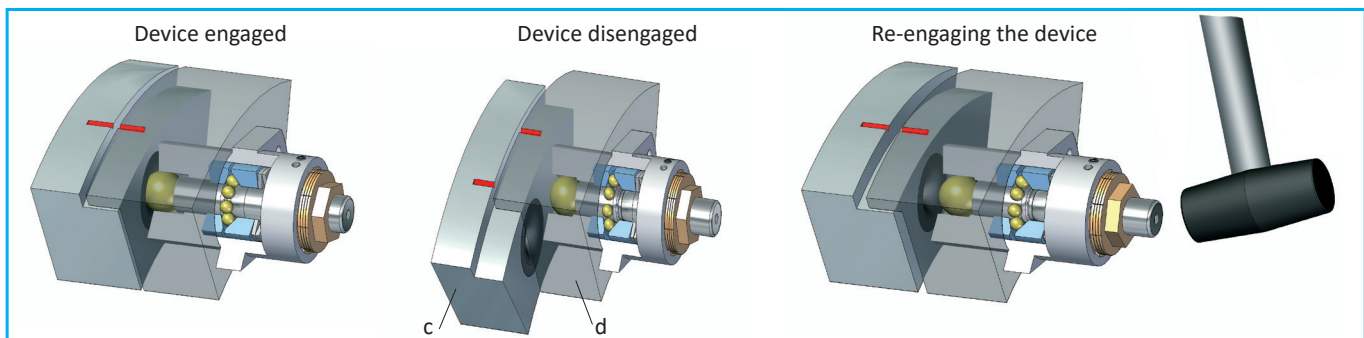

DSM - modular torque limiters (free rotation) : additional information

OPERATION

This model of freely rotating limiter DSM has been specifically designed to protect against overload in heavy industry machines with significant powers and inertia and high speed of rotation.

The seals present protect from dust, dirt and prevent leakage of grease used within.

In nominal operating conditions the transmission torque is transferred from the driving to driven components by a different number of modules assembled symmetrically on an outer circumference of the device with the possibility of different configurations of springs inside them.

In case of overload, when the torque demand from the driven portion exceeds that of calibration, the balls will be forced out of the seat area and by doing so axially move the central pistons within the modules. This release occurs instantaneously separating the driver and driven sections allowing free rotation of the section still rotating until the transmission is stopped.

The device can also be equipped with a overload detection ring (DSM/SI), connected to the central pivots of the various modules, to be able to "read", through an electromechanical switch (model ComInTec: EM1) or an inductive sensor (model ComInTec: PRX), the axial movement and send an electrical signal to trigger an alarm and stop the transmission.

The re-engagement of the individual modules must be done with the machine stopped as described in the previous section devoted to it.

HOW TO USE AND ASSEMBLE

The device comes complete with finished bore, unless otherwise noted, with tolerance H7 and keyway DIN6885-1 with H9 tolerance.

The fixing of the device can be made axially through the bore with a washer or on request an internal locking assembly.

The device is NOT self-supporting so it is necessary to provide ensure that the shaft on which the device will be mounted are supported with bearings and in the case of shaft to shaft connection the misalignment values detailed in the catalogue are noted.

MAINTENANCE

These devices, are maintenance-free.

In the case of the torque calibration it is important to take into account several variables that combined together can affect the duration of the limiter:

- Torque value of intervention in relation to the actual range of the limiter.
- The frequency and duration of interventions.
- Ability to dissipate the heat generated by slippage or disengagement.
- Speed of rotation.
- Environmental conditions at work.

ORDER EXAMPLE

