



ComInTec[®]
Safety in Power Transmission

TORQUE LIMITER FREE ROTATION

up to 1,300 Nm and 65 mm bore diameters



ED. 07/2021

DSS/SG /RF



- Download catalogue
- Download instruction sheets
- Download 3D and 2D cad model

DSS/SG/RF - torque limiter free rotation: introduction



- ⦿ Absence of torsional play during the transmission of motion.
 - ⦿ Fine-tuning the torque through a balanced radial ring.
 - ⦿ Motion transmission through balls.
 - ⦿ An innovative calibration system with "H dimension" for an immediate calibration of the equipment.
 - ⦿ Manual re-engagement.
 - ⦿ No residual torque after disengagement.
 - ⦿ Possibility of combining a switch / proximity to stop the engine.
- ON REQUEST
- ⦿ Complete transmission gear worked and fitted (crown, pulley, gear, ...).
 - ⦿ Can be supplied with various types of rigid/elastic couplings for in-line shafts transmission.
 - ⦿ Possibility of surface treatments for corrosion-specific needs.
 - ⦿ Possibility of connection with 8 holes interchangeable with other products on the market.

A backlash free Safety coupling with free rotation and no residual torque suitable for high speed transmission. The disengagement is instantaneous once the torque is reached, the calibration is adjusted by changing the pressure of the springs. The re-engagement is manual, quick and reliable.

APPLICATIONS

- ⦿ Extruders.
- ⦿ Packing machines.
- ⦿ Automation technology.
- ⦿ Test benches.

ADVANTAGES AND BENEFITS

- ⦿ Protect the elements of a transmission even in case of high inertias.
- ⦿ Protect the product from shock or incorrect positioning.
- ⦿ Protect devices during transmission at high speeds of rotation.
- ⦿ Greater durability of all devices, thanks to the free rotation.

	.../DSS/SG/RF: version suitable for immediate release to overcome Torque calibration; low residual torque after disengagement.	from 5 to 1,300 Nm 65 mm max bore	Pag. 46
	... + GAS/SG: connection with flexible coupling and locking clamp for quick installation.	from 5 to 1,300 Nm 70 mm max bore	Pag. 48

ATEX CONFORMITY



The DSS/SG/RF device can be supplied in compliance with Directive 2014/34/EU (ATEX) relating to equipment and protection systems intended for use in potentially explosive atmospheres.

Marking is carried out on the hub as required by the directive assembly, program checks as described in the use and maintenance manual supplied with the device.

II 2G Ex II B T5 Gb -15 °C ≤ Ta ≤ + 80 °C

ASSEMBLY EXAMPLES

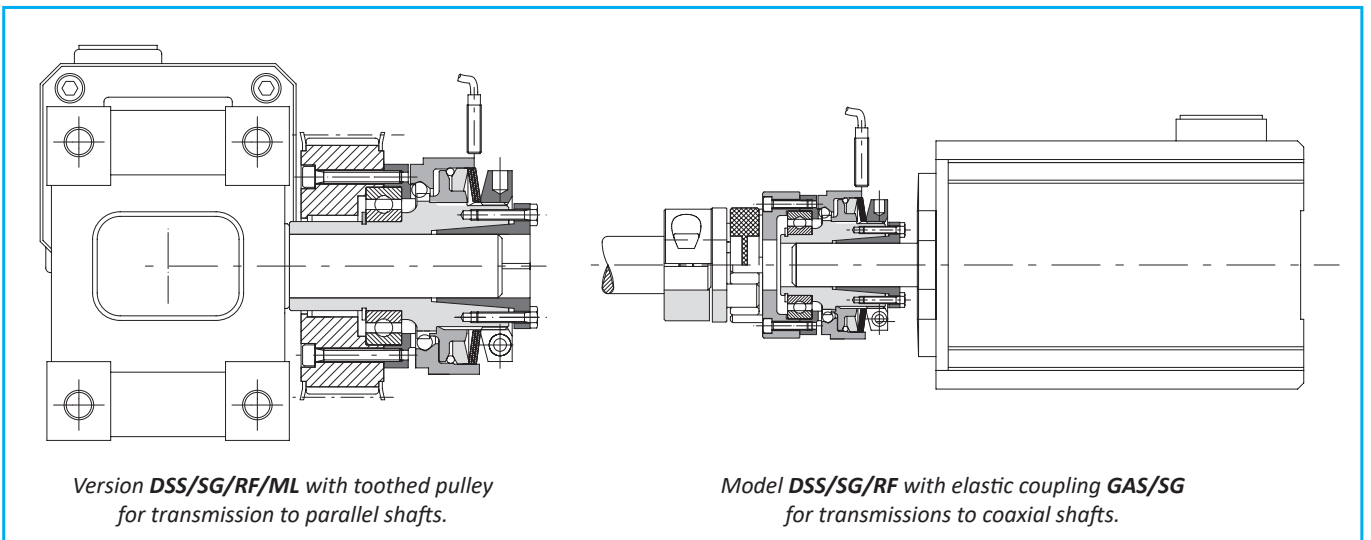

OPERATION

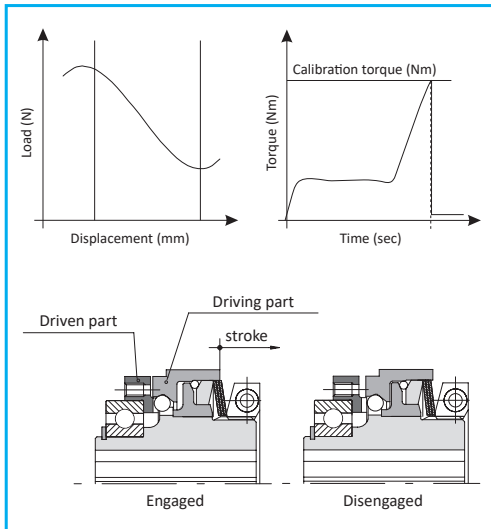

This model of torque limiter negative version to incorporate the following features:

- ⦿ Backlash free with compact dimensions
- ⦿ Instantaneous reduction of the couple at the time of overloading
- ⦿ Absence of residual torque, after disengagement
- ⦿ Immediate response times and high sensitivity

Suitable for protecting against overloads within automatic machines with significant powers and inertias and high rotation speeds. When an overload occurs an immediate and complete separation of the drive and driven occurs and will remain disconnected in free rotation until it is re-engaged manually or using a suitable tool. A possible micro switch or sensor detects the movement of the movable base by generating an electrical signal necessary to stop the transmission. This electrical signal can also be used for further control functions. Electromechanical microswitches model EM1 or EM2 or inductive sensors model PRX, available from Comintec.

TORQUE ADJUSTMENT

Adjustment of the Negative version is opposite to all other units in our range. Unlike the traditional units, by rotating the adjuster nut clockwise the disengagement torque will reduce, and therefore to increase the torque the nut must be rotated anti-clockwise. To assist the operator in setting, there are clear markings on the nut showing 75% of the max torque and +/- Min/Max directions indicated.

Unless otherwise requested, these models are supplied pre-calibrated at 75% of the maximum torque value of the spring's chosen configuration.

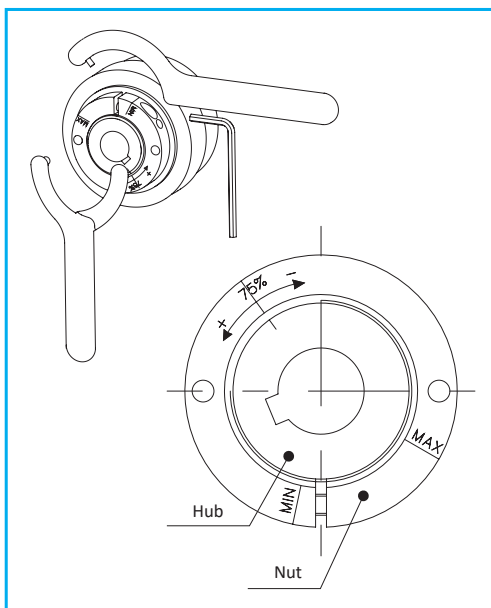

HOW TO USE, ASSEMBLE AND RE-ENGAGEMENT

The device is supplied ONLY with finished bore in the hub, unless otherwise specified, with tolerance H7 with integrated locking assembly or keyway according to UNI 6604 (DIN 6885-1) with tolerance H9.

The device can be fixed axially by a screw and washer for the version with hole and keyway or by the locking device integrated in the version with this. The device is NOT self-supporting so it is necessary to provide that the shafts on which it will be fitted are with bearings and are supported in the case of the application are met with coupling misalignment shown in the catalog.

The re-engagement can take place only and exclusively when the machine is stopped. Occurs simply by moving the external mobile base in the opposite direction to the ring nut by exerting a slight axial pressure manually for low torques or by using a tool that can act as a lever for larger torques.

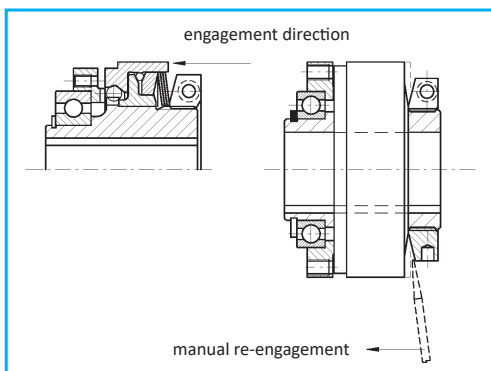

MAINTENANCE

These devices, mechanical, are maintenance-free.

In the case of the torque is appropriate to take account of different variables that combined together can affect the length of the limiter:

- Torque intervention in relation to the range provided by the limiter.
- Whether the frequency and duration of interventions.
- Ability to dissipate heat generated by the sliding.
- Speed of rotation.
- Environmental working conditions.

DSS/SG/RF - torque limiter free rotation: technical data



- ⊙ Simple manual re-engagement without special equipment.
- ⊙ Suitable to be installed in the kinematic chains with high inertia.
- ⊙ Available according to ATEX conformity: II 2G Ex II B T5 Gb -15°C ≤ Ta ≤ + 80°C.
- ⊙ Organ mounted and directly supported by a ball bearing.
- ⊙ Model available only with finished bore (with keyway or with locking assembly).
- ⊙ Torque range: 5-1,300 Nm; ø65 mm maximum bore.

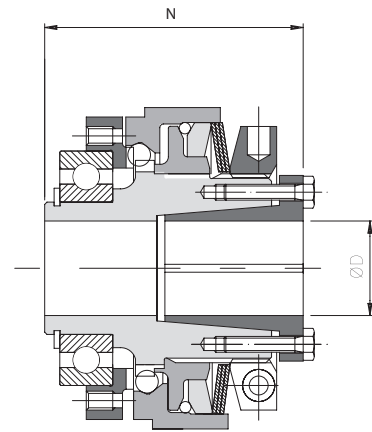
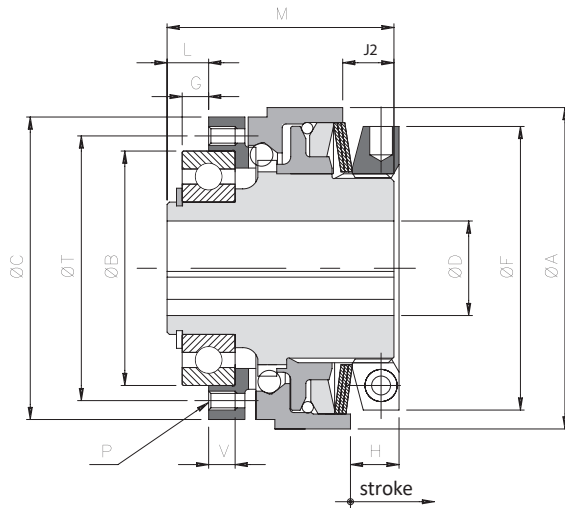

DIMENSIONS

Size	A	B h5	C	DH7	F	* G	L	J2	P	M	N	T	V	▲ On request "8C"						
				Max.		B h5								C	G	L	P	T	V	
0.63	70	42	65	20	62	4	7	12	6xM5	50	57	48	7	47	-	5	8	8xM4	56	6
1.80	85	62	80	25	75	7	11	13,5	6xM5	60	68	70	7	-	-	-	-	8xM5	71	-
2.96	100	75	96	35*	82	9	14	16	6xM6	70	78	89	9	-	95	-	-	8xM6	85	-
3.116	120	90	115	42	97	8	14	18	6xM8	88	97	105	12	-	110	10	16	8xM6	100	10
4.138	138	100	138	50	117	6,5	14,5	20,5	6xM10	100	111	125	14	-	130	10	18	8xM8	116	11
▲ 5.172	172	130	172	65	145	11	20	33	6xM12	130	145	155	18	-	166	12	21	8xM10	150	15

TECHNICAL DETAILS

Size	Torque [Nm]				Stroke [mm]	Locking assembly		Inerzia [kgm²]			Max speed [Rpm]	Weight [Kg]	
	T1	T2	T3	T4		Screws	Tightening torque [Nm]	Flange side	Nut side			cava	Locking assembly
									keyway	Locking assembly			
0.63	5 - 14	10 - 30	20 - 50	-	1,8	6xM4	4,1	0,00008	0,00039	0,00040	8000	1,2	1,2
1.80	9 - 30	20 - 70	30 - 100	-	2	8xM4	4,1	0,00029	0,00115	0,00118	7000	2	2,1
2.96	20 - 54	40 - 95	-	80 - 200	2,5	10xM4	4,1	0,00068	0,00257	0,00264	6000	3,6	3,8
3.116	50 - 95	90 - 185	-	180 - 400	4	8xM5	8,5	0,00129	0,00473	0,00493	5000	5,0	5,4
4.138	70 - 190	125 - 345	-	300 - 720	4,5	8xM6	14	0,00315	0,01083	0,01132	4000	8,7	9,3
▲ 5.172	120 - 350	230 - 650	-	500 - 1300	5	8xM8	35	0,01012	0,03302	0,03380	3500	13,0	13,4

▲ On request

NOTES

- DH7*: maximum diameter for finished bore with reduced keyway according to UNI 7510.
- G*: assembly tolerance +0,1.
- Weights are relevant to the pilot bore; inertias refer to the maximum diameter for finished bore of the torque limiter.
- Microswitches EM1 or EM2 and inductive sensor PRX see page 73

... + GAS/SG - model with jaw coupling and single split clamp hub type "B": technical data

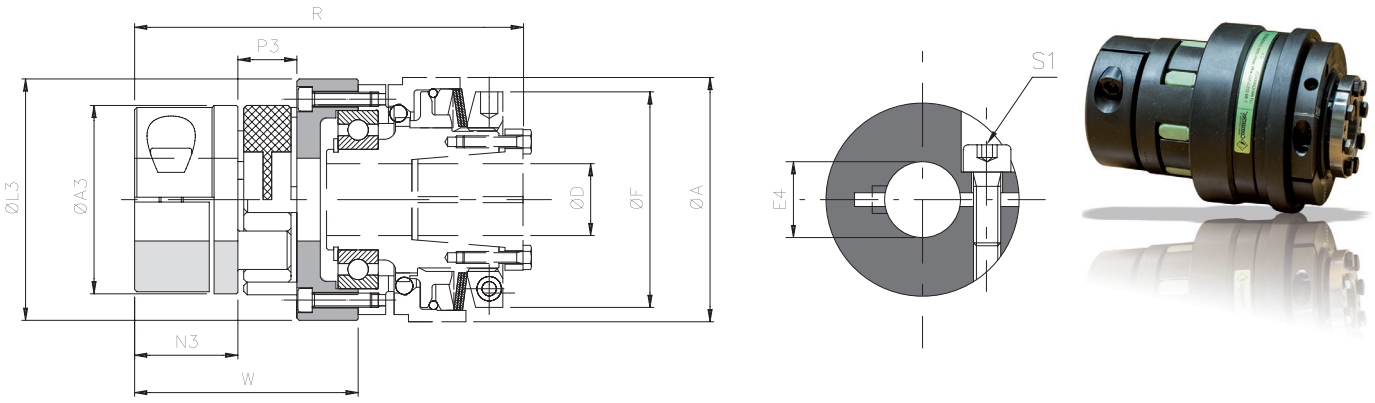

DIMENSIONS

Size		Torque [Nm]		A3	E4 H7 max	L3	N3	P3	A	D H7	F	W	R
/RF	GAS SG	Nom	Max							max			
0.63	0	60	120	55	30	65	30	18	70	20	62	63	112
1.80	1	160	320	65	35	84	35	20	85	25	75	74,5	131,5
2.96	2	325	650	80	45	102	45	24	100	35	82	93	157
3.116	3	450	900	95	50	122	50	26	115	42	97	100	183
4.138	4	525	1050	105	60	143	56	28	135	50	117	110,5	207
5.172	6	900	1800	135	70	178	75	35	165	65	145	147	247

TECHNICAL DETAILS

Size		Clamp hub		Misalignments			Rigidity			Inertia coupling side [kgm²]	Max. speed [Rpm]	Weight [kg]
/RF	GAS SG	Screws	Tightening torque [Nm]	Angular α [°]	Axial X [mm]	Radial K [mm]	Torsional static [Nm/rad]	Torsional dynamic [Nm/rad]	Radial [N/mm]			
0.63	0	M6	15	0° 54'	1,4	0,10	3650	8100	2900	0,00040	8000	0,7
1.80	1	M8	36		1,5	0,11	4180	10700	3650	0,00107	7000	1,7
2.96	2	M8	36		1,8	0,12	8150	21850	5000	0,00296	6000	1,9
3.116	3	M10	70		2,0	0,15	15000	34000	5900	0,00559	5000	3,2
4.138	4	M12	121		2,1	0,16	16000	49000	6800	0,01213	4000	5,8
5.172	6	M12	121		2,6	0,18	38000	97000	6400	0,04301	3500	13

TRANSMITTABLE TORQUE WITH CLAMP HUB ASSEMBLY TYPE "B"

Size GAS/SG	Transmission torque [Nm] according to the ϕ finished bore [mm]																												
	8	10	11	12	14	15	16	18	19	20	22	24	25	28	30	32	35	38	40	42	45	48	50	55	60	65	70	75	
00 (19)	45	47	49	50	52	53	55	57	58	60																			
0 (24)		77	78	80	83	84	86	88	90	91	94	97	98	103	106														
1 (28)					158	161	164	169	171	174	179	184	187	194	199	204	212												
2 (38)								193	196	198	203	208	211	218	223	228	236	243	248	253	260								
3 (42)										342	350	357	361	372	379	387	398	409	417	424	435	446	454						
4 (48)												569	585	596	607	623	639	650	661	677	693	704	731	758					
6 (65)																753	769	780	791	807	823	834	861	888	915	942	970		

▲ On request

NOTES

- These details refer only for the coupling (GAS/SG with backlash free red element 98 Shore-A), for torque limiters details see on page 46.
- Weights are relevant only to the pilot bore (GAS/SG); inertias refer only the coupling with maximum bore (GAS/SG).
- Microswitches EM1 or EM2 and inductive sensor PRX see page 73

DSS/SG/RF - torque limiter free rotation: additional information

OTHER COUPLING TYPES AVAILABLE ON REQUEST

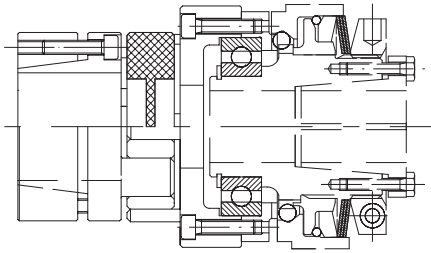

Model **DSS/SG/RF** with backlash free jaw elastic coupling
GAS/SG/CCE with integrated locking assembly when is required
 to accomodate misalignment with high torsional rigidity.

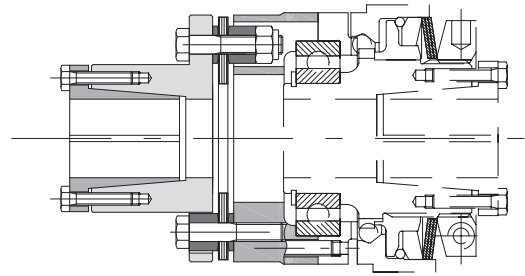

Model **DSS/SG/RF** with single flexing disc coupling **GTR/S**,
 for applications where torsional rigidity is required.

ORDER EXAMPLE

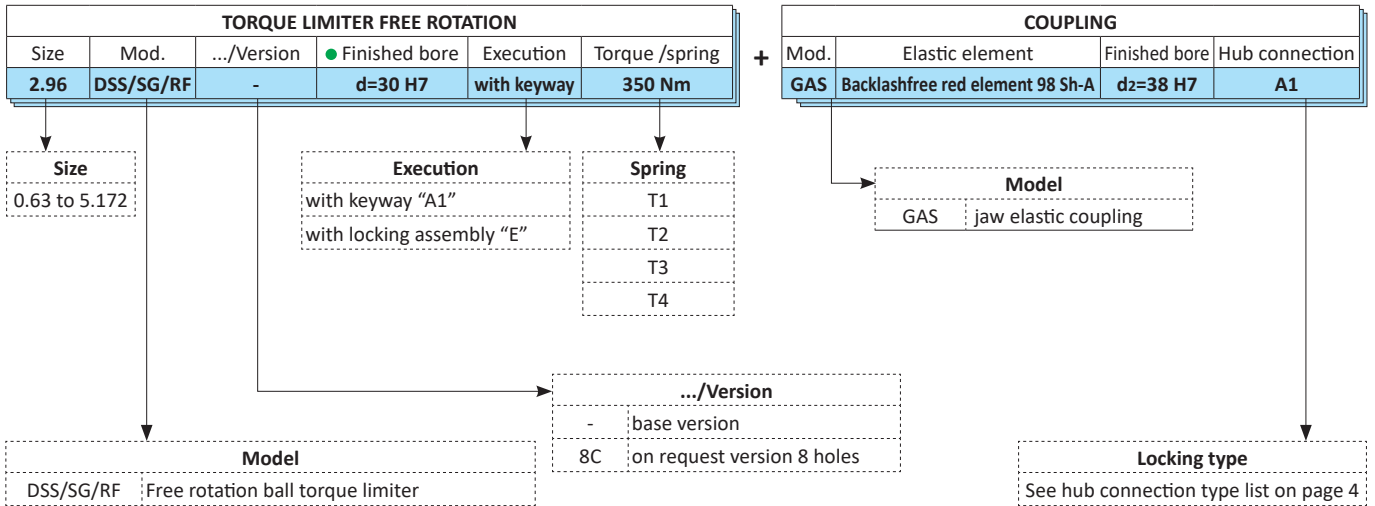

● Model available only with finished bore.