

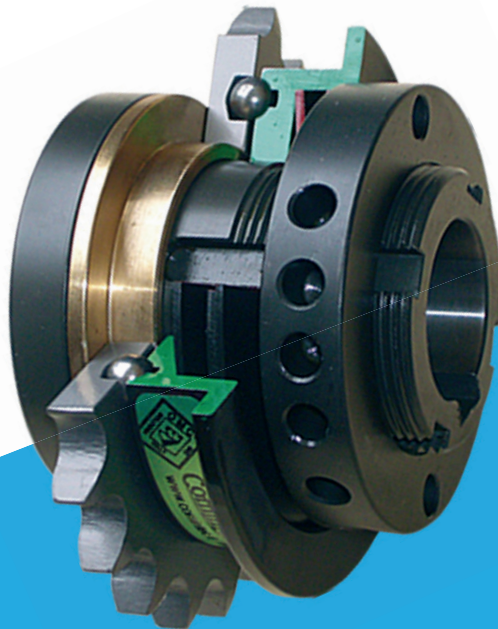

**ComInTec**<sup>®</sup>  
Safety in Power Transmission

# ECONOMIC BALL TORQUE LIMITER

up to 1,450 Nm and 55 mm bore diameters



ED. 07/2021



- Download catalogue
- Download instruction sheets
- Download 3D and 2D cad model



# EDF

# EDF/F - economic ball torque limiter: introduction



- ⊙ Reduced torsional backlash by ball drive.
  - ⊙ Maintenance free for long lasting, high reliability.
  - ⊙ Version with 360° phase re-engagement available.
  - ⊙ Model available only with plate wheel or other transmission component.
  - ⊙ Innovative calibration system by “H dimension” for an immediate calibration of the device.
  - ⊙ Possibility of combining a microswitch / proximity to stop the drive.
  - ⊙ Suitable for use in damp and oily environments.
- ON REQUEST
- ⊙ Complete with drive component or personalized plate wheel.
  - ⊙ Possibility of connections with locking assembly or other types of locking.
  - ⊙ Possibility of surface treatments for corrosion-specific needs.
  - ⊙ Personalized version with re-engagement in phase at 30°, 45°, 60°, 90°..

Safety coupling with the transmission of motion by means of hardened balls inserted directly in the drive element, obtaining a simple, compact and competitive device. The disengagement occurs quickly and safely allowing the stop of the transmission if the calibrated torque is exceeded.

	EDF/F: basic model for drive with platewheel or pulley, with parallel shafts	from 7,5 to 1450 Nm 55 mm max. bore	Page 19
	EDF/F/TAC: in-line shaft connection, simple and economic	from 7,5 to 1450 Nm 80 mm max. bore	Page 20

## MAIN APPLICATION

- ⊙ Filling machines.
- ⊙ Metal chip conveyors.
- ⊙ Automatic conveyor belts.
- ⊙ Winches.

## ADVANTAGES AND BENEFITS

- ⊙ Protects the product from damage or wrong positioning.
- ⊙ Protect the gear motor from accidental product collisions.
- ⊙ Protect the drive against bumps or limit.
- ⊙ Protects conveyor belts in case of product collisions.

## ORDER EXAMPLE

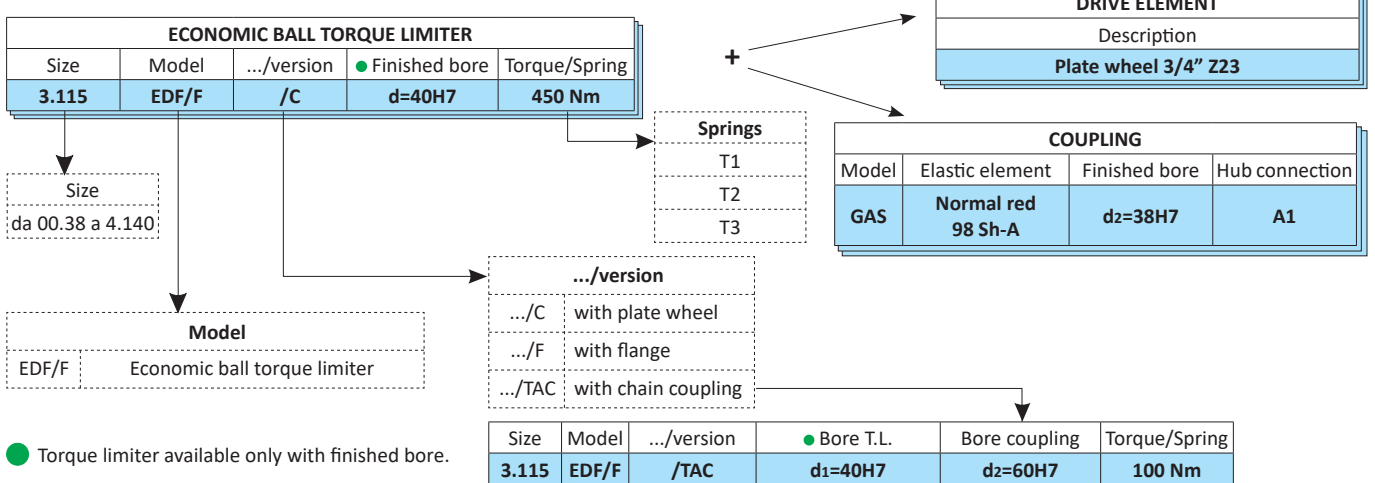

## APPLICATION EXAMPLE

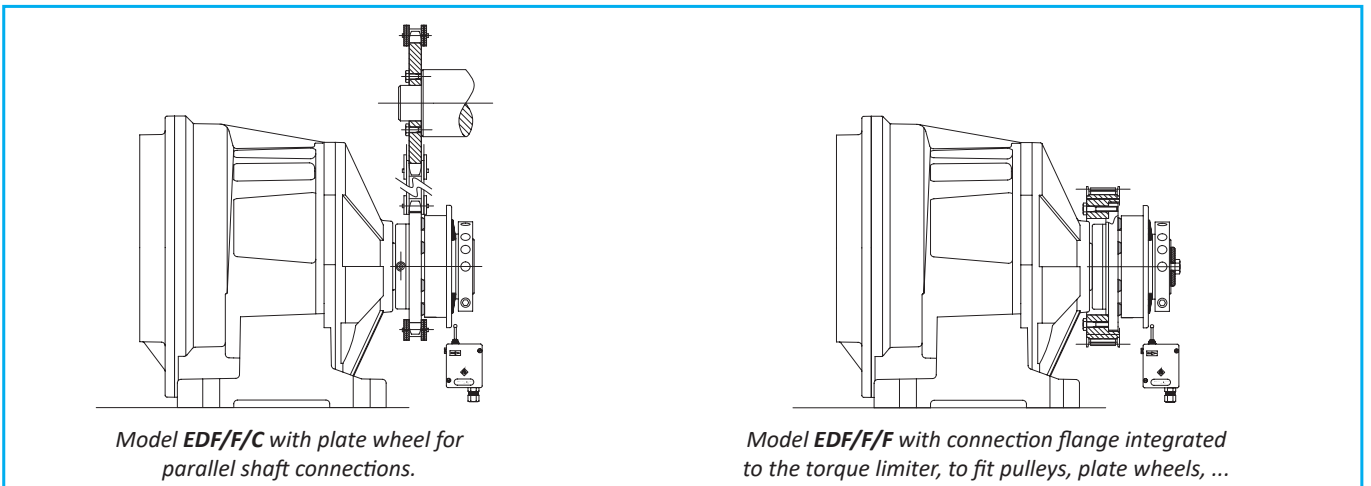

# EDF/F - economic ball torque limiter: technical data

- Mounting of the drive organ within the device similar to the friction series.
- Automatic re-engagement after the restoration of transmission.
- Available with radial ring statically balanced
- Model with flange for custom links: EDF/F/F.
- Model available only with finished bore.
- Torque range from 7.5 to 1,450 Nm; max. bore  $\varnothing 55$  mm.

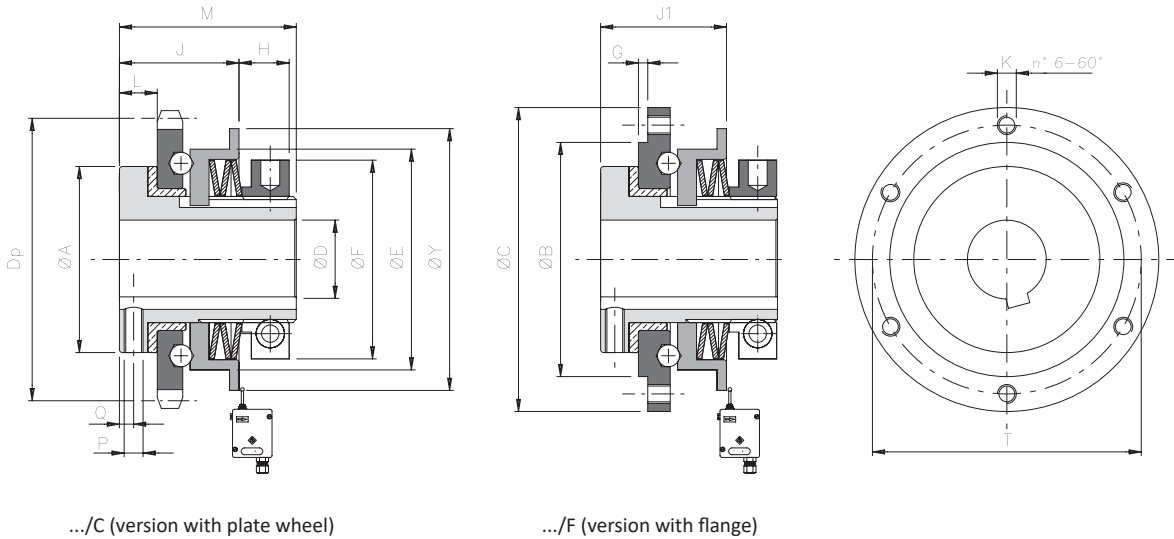

## DIMENSIONS

Size	A	B h7	C	D H7		E	F	G	J1	K	L	M	P	Q	T	Y	Standard platewheel		
				pilot bore	max												lead	Dp	J
00.38	30	35	52	-	12	38	35	1	21	M4	6	33	M3	2	44	48	3/8" Z16	48,82	20,5
0.50	40	50	68	-	20	50	42	1,5	26	M5	8	42	M4	3	58	63	3/8" Z20	60,89	24,5
1.70	59	65	90	-	25	70	63	2	36	M5	11	55	M6	4	80	83	1/2" Z22	89,24	34
2.90	72	85	112	-	38	90	82	2	40	M6	12	61	M6	4,5	100	103	3/4" Z18	109,71	40
3.115	89	110	140	18	45	115	104	2	51	M8	14	71	M6	5,5	125	128	1" Z17	138,22	53
4.140	104	135	174	24	55	140	128	2	57,5	M10	15	86	M8	5,5	155	153	1" Z20	162,38	58,5

## TECHNICAL DETAILS

Size	Torque [Nm]			Stroke [Nm]	Inertia [Kg <sup>m</sup> ²]		Max speed [Rpm]	Weight [Kg]	
	T1	T2	T3		Flange side	Nut side		EDF/F/C	EDF/F/F
00.38	7,5 - 15	14,5 - 30	-	1	0,000024	0,000032	1900	0,2	0,3
0.50	8 - 24	15 - 40	40 - 60	1,5	0,000076	0,000097	1400	0,5	0,7
1.70	12 - 37	30 - 68	53 - 120	2	0,000331	0,000562	1200	1,3	1,3
2.90	-	60 - 150	140 - 290	2,5	0,001001	0,001605	1000	2,4	2,5
3.115	-	145 - 385	215 - 580	3	0,003302	0,004868	800	4,1	4,1
4.140	-	-	550 - 1450	3	0,008578	0,012687	650	6,9	7,1

▲ On request

## NOTES

- Weights are relevant to the torque limiter with pilot bore (EDF/F/TAC), inertias refer to the torque limiter (EDF/F/TAC) hole max.
- Microswitches EM1 or EM2 and inductive sensor PRX see page 73

## .../TAC - version with chain coupling: technical data

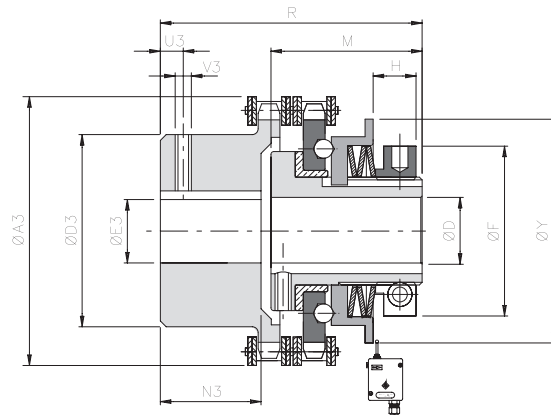

### DIMENSIONS

Size	Torque [Nm]	D H7		F	Y	M	R	A3	D3	E3 H7		N3	U3	V3	Disallineamenti			Velocità max [Rpm]	Peso [Kg]
		pilot bore	max							pilot bore	max				Angolare $\alpha$ [°]	Assiale X [mm]	Radiale K [mm]		
00.38	7,5-30	-	12	35	48	33	60	58	37	10	20	20	5	M3	2°	1,50	0,20	1900	0,6
0.50	8-60	-	20	42	63	42	67	75	50	12	28	19	8	M4		1,50	0,20	1400	1
1.70	12-120	-	25	63	83	55	91	101	70	16	38	29	12	M6		2,40	0,25	1200	2,9
2.90	60-290	-	38	82	103	61	107	126	89	20	55	38	12	M6		3,20	0,30	1000	6,1
3.115	145-580	18	45	104	128	71	136	159	110	20	70	56,5	15	M8		4,50	0,35	800	9,5
4.140	550-1450	24	55	128	153	86	156	184	130	28	80	59,5	15	M8		4,80	0,40	650	20

▲ On request

## ... + GAS - model with jaw coupling: technical data

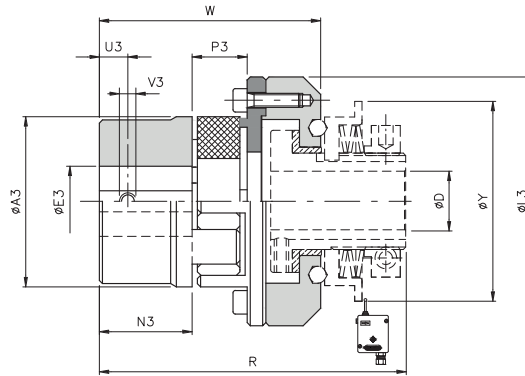

### DIMENSIONI E CARATTERISTICHE TECNICHE

Size		Torque * [Nm]		A3	E3 H7 max	L3	N3	P3	U3	V3	D H7		Y	R	W	Misalignments *			Max speed [Rpm]	Weight [Kg]
EDF/F	GAS Std	Nom	Max								pilot bore	max				Angolare $\alpha$ [°]	Axial X [mm]	Radial K [mm]		
00.38	00 (19)	17	34	40	25	58	25	16	10	M5	-	12	48	86,5	64	1°18'	-0,5/+1,2	0,20	10000	0,4
0.50	0 (24)	60	120	55	35	74	30	18	10	M5	-	20	63	103	74,5		-0,5/+1,4	0,22	7600	0,8
1.70	1 (28)	160	320	65	40	107	35	20	15	M8	-	25	83	125	90		-0,7/+1,5	0,25	5450	2,5
2.90	2 (38)	325	650	80	48	132	45	24	15	M8	-	38	103	146,5	108,5		-0,7/+1,8	0,28	4250	4,5
3.115	4 (48)	525	1050	105	62	164	56	28	20	M8	18	45	128	175,5	132,5		-1/+2,1	0,36	3350	8,5
4.140	6 (65)	940	1880	135	80	208	75	35	20	M10	24	55	153	220	166		-1/+2,6	0,42	2750	17

▲ On request

### NOTES

- Weights are relevant to the whole group with pilot bore
- EDF / F + GAS: (torque and misalignments) \*: The data refers to the standard red elastomer 98 Sh-A. The weights refer to the coupling application only.
- For Torque limiter data see on page 19
- Microswitches EM1 or EM2 and inductive sensor PRX see page 73