

C2-10

Control and protection
of electric actuators

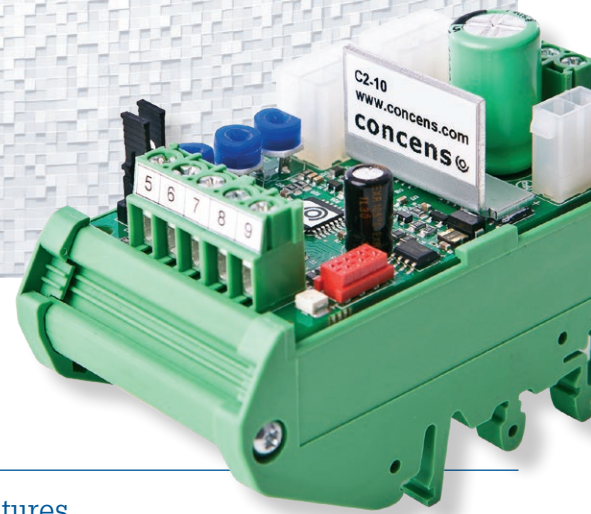

The C2-10 is developed for controlled ON-OFF Operating and direction change of Concens actuators. The C2-10 has advanced current limit features. It limits the actuator current in start-up, braking and jam-situations and in that way protects the motor and the application. The C2-10 also has a fault in- and output which indicates error/over-current status and can be used to stop the actuator (for example if an emergency-stop switch is used). The C2-10 is only suitable for use with actuators without hall sensors.

The start and stop ramp times are individually adjustable to suit each application. In other words the motor voltage can be controlled to give a preferred smooth start and stop. When the C2-10 controller is without power, the motor is dynamically braked with so called short-circuit braking, i.e. the motor poles are connected together. The reverse and forward inputs can be set to work with negative or positive voltage by moving a jumper (See Fig. 3).

This datasheet is related to C2-10 firmware version 1.7 (v1.7) only.

Features

- Adjustable start ramp
- Adjustable stop ramp
- Adjustable current limit
- Continuous-mode, impulse-mode
- High momentary load capacity
- Easy interfacing to PLC etc.
- Connectors and terminals
- DIN-rail fittable
- Status LED

Technical Data

Supply	12/24 VDC (filtered max ripple < 30 % @ full load)
Over voltage protection	40 V
Idle current	Approx. 15 mA
Driving current	10 A continuous, 16 A with duty cycle 50 % Max 16 A on duty 2 min
Current limit	0,5 ... 16 A
Current trip delay	20 ms
Start delay	5 ms
Voltage loss	0,5 V ($I_{motor} = 4 A$)
PWM frequency	2 kHz
Ramps	0,1 ... 2,5 s
Digital inputs	'High' @ $U_{in} 4 V \rightarrow$ supply voltage, 'Low' @ $U_{in} 0 V \rightarrow 1 V$
Operating temp. (T_a)	- 20 °C to + 60 °C
Weight	36 g
Dimensions	73 x 42 x 26 mm (L x W x H)

C2-10

FIG. 1 WIRING FOR C2-10

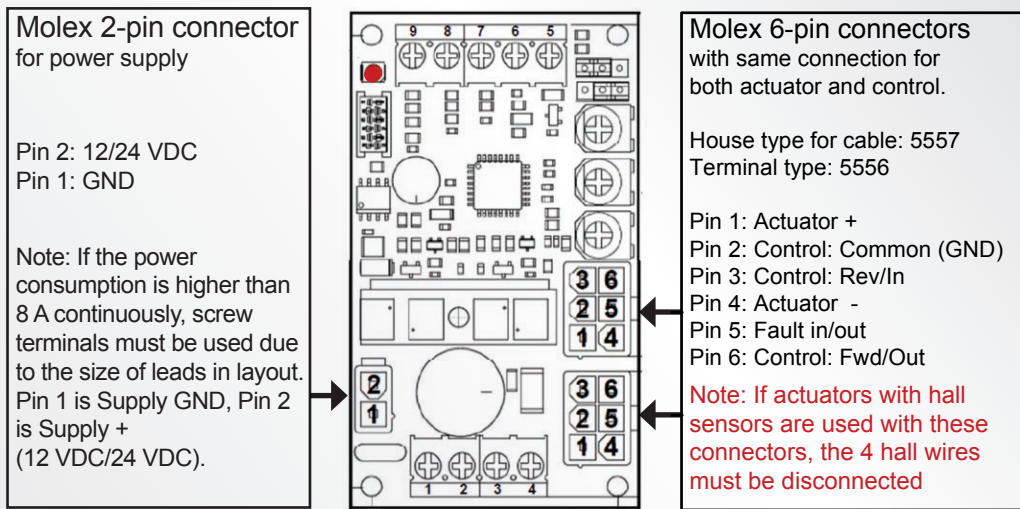

General

Status LED signals:

Fast blink:	Current trip
Four blinks:	Overvoltage
Solid light:	Overtemp
One long blink followed by two short blinks:	Fault input active

The C2-10 has a 'trip' feature that cuts the motor voltage if the current limit value is exceeded (after trip delay of 20 ms). After trip the motor can only be started in the opposite direction. Additionally the C2-10 provides 'kick-start' which translates to 100 ms at full speed (100 % PWM). Current limit during kick-start is up to 55 A.

If the actuator is stopped without going into trip mode, the C2-10 controller will allow 50 % higher current from start and until 500 ms after ending start ramp (see timing figure).

The fault terminal is both input and output (see fig. 2). During normal operation the signal is pulled high to 5,4 V on the C2-10 board in series with a 100 kΩ resistor. When a fault occurs the fault terminal changes to low voltage (GND via 100 Ω resistor).

Screw Terminals

- 1 Supply GND
- 2 Supply + (12/24 VDC) fuse required
- 3 Actuator + red wire
- 4 Actuator – black wire
- 5 + 5,4 V output for control-use max. 10 mA load
- 6 Fault in- and output
- 7 Reverse (Rev/In) signal input (0,5 mA)
- 8 Forward (Fwd/Out) signal input (0,5 mA)
- 7+8 Used to activate the actuator reverse and forward. Please refer to description of 'Control mode' on page 3
- 9 GND for control-use (not to be used as supply input)

C2-10

FIG. 2 CIRCUIT DIAGRAM

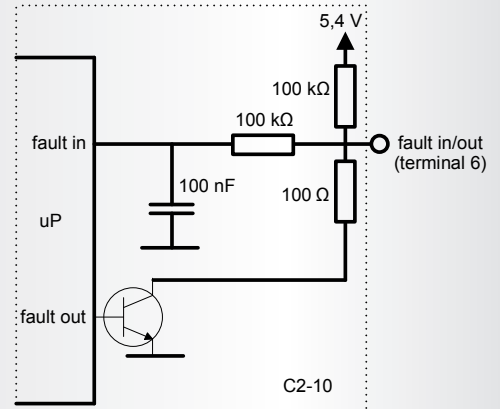
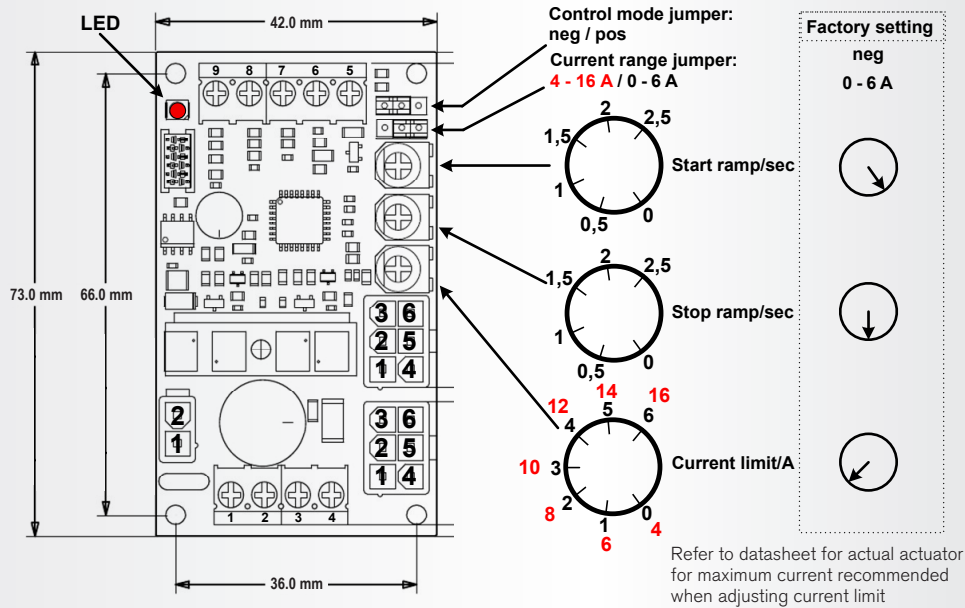

FIG.3 SETTINGS AND MECHANICAL DIMENSIONS



Control mode

When jumper is put in mode 'neg' (left hand side) a negative (GND) signal is put on terminal 7 and 8 to run motor.

When using 'neg' mode, terminal 9 can be used as the negative supply.

When jumper is put in mode 'pos' (jumper in right side) a positive (> 4 V) signal is put on terminal 7 and 8 to run motor.

When using 'pos' mode, terminal 5 can be used as the positive supply.

NOTE: When using the connectors for remote control, the jumper MUST be in 'neg' mode (left side).

Input current for reverse & forward control is 0.5 mA.

Parameter #1 is as default set to '0' which enables 'continous mode'. If #1 is changed to '1' 'impulse mode' is enabled. Use C2-USB/C2 Config Tool Light for changing. Warning: Do not change other parameters.

FIG. 4 TIMING DIAGRAM

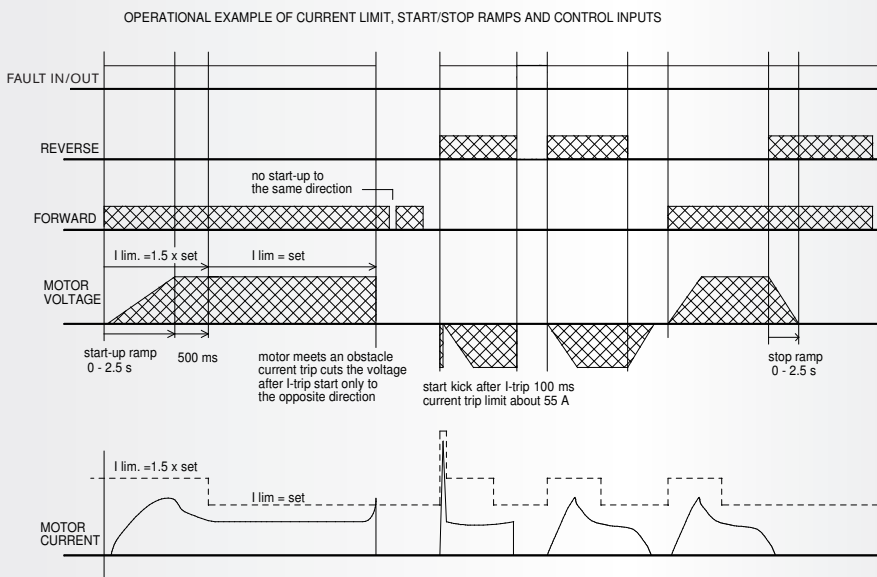

C2-10



C2-10-PCB-00-0000-00
board alone, weight 36 g
73 x 42 x 26 mm (L x W x H)



C2-10-DIN-00-0000-00
DIN rail version, weight 66 g
90 x 46 x 56 mm (L x W x H)



C2-10-BOX-00-0000-00
BOX version, weight 64 g, IP55
102 x 73 x 47 mm (L x W x H)

BOX-version is not for use with Molex Minifit, only open ends.

C2-10 Part number combination

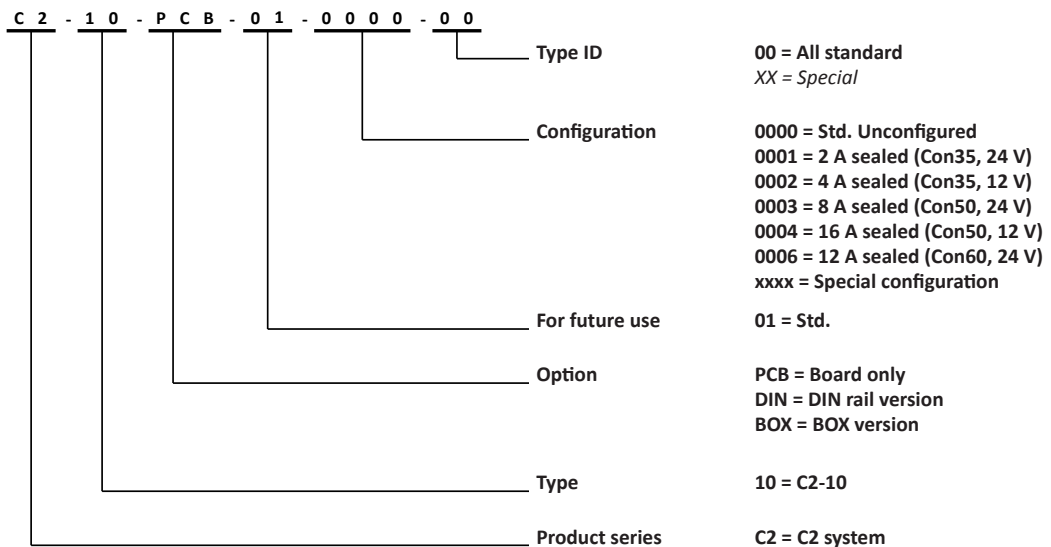

Recommendations and warnings

- Attention! C2-10 controller has no fuse in it. Use external fuse according to application.
- If C2-10 goes into "trip" (overcurrent), it is only possible to run actuator in opposite direction.
- Please adjust the max. current to be 10 % higher than maximum current during running the actuator. This ensures the best possible conditions for mechanical and electrical longevity.
- It is very important to ensure that the power supply for the controller is capable of supplying sufficient current – otherwise the controller and the actuator may be damaged.
- Double-check correct polarity of power supply. If wrong connected, the C2-10 will be damaged.
- If wire colors differ from what is expected, please check with supplier or check on our YouTube channel before connecting the actuator to the controller.
- Braking load resistor (C2-A23) for suppressing flyback is available.

Disclaimer

- Concents products are continuously developed, built and tested for highest requirements and reliability but it is always the responsibility of the customer to validate and test the suitability of our products in a given application and environment. Concents products must not be used in safety critical applications.
- We do our utmost to provide accurate and up-to-date information at all times. In spite of that, Concents cannot be held responsible for any errors in the documentation. Specifications are subject to change without prior notice.

For more information, please visit our website at www.concents.com

C2-10

