

# PRODUCTS

The *Motion Coordinator* system is extremely modular, allowing the user to tailor the controller to their specific applications, this also allows the flexibility to incorporate new modules if the need should change, making the system “future proof”. Systems may be used with a stand alone program or alternatively commands can be sent from an external computer.

All *Motion Coordinators*, whether panel mount, rack mount, DIN-rail mount or a custom design format, allow digital or analogue I/O expansion with Trio's I/O modules. Special I/O requirements can also be accommodated using the CANopen protocol to control third party I/O modules. The Flexslice System offers fast high performance EtherCAT devices for Trio's range of EtherCAT *Motion Coordinators*.

Trio's UNIPLAY range of operator interfaces provide a robust and functional HMI using the Ethernet network. Third party HMI products, touchscreens, etc. can communicate to the *Motion Coordinator* via the Modbus-RTU serial protocol.

## System Set-Up

The MC4/5/6 range includes advanced networking technology for connection to Digital Servos, CANbus and Factory Networks. Access to all parts of the system by network connections allows reduced down-time with automated fault reporting and analysis.

With a MC664 *Motion Coordinator*, it is possible to control a machine with up to 128 axes (64 stepper/servo and 64 virtual), 1024 digital inputs, 1024 digital outputs, 32 analogue inputs and 16 analogue outputs.

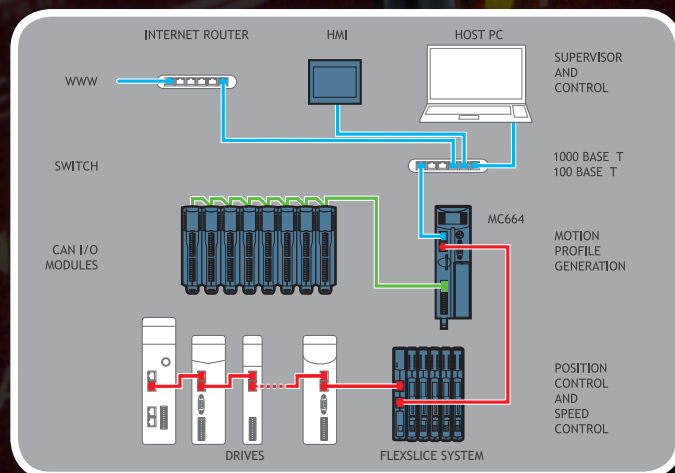

Preliminary specifications may change without notice

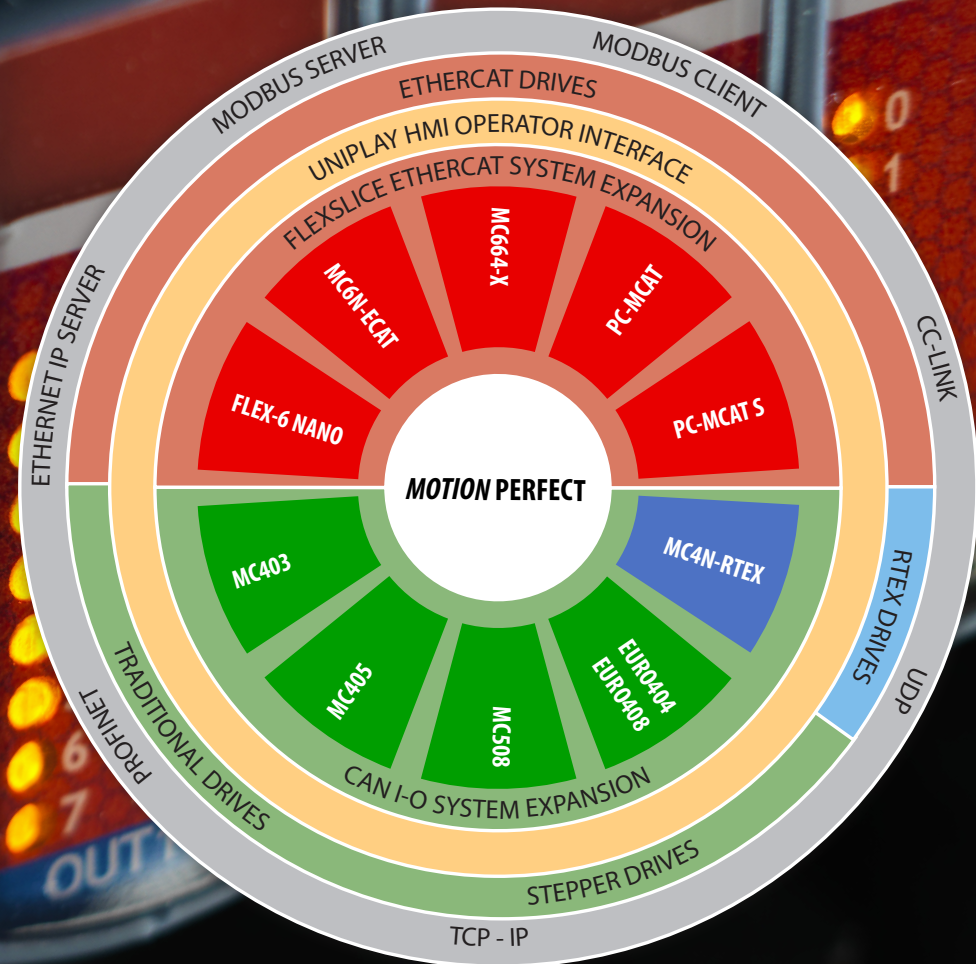

UK | USA | CHINA | INDIA | [WWW.TRIMOTION.COM](http://WWW.TRIMOTION.COM)



# Flexslice System

## Flexible EtherCAT Devices

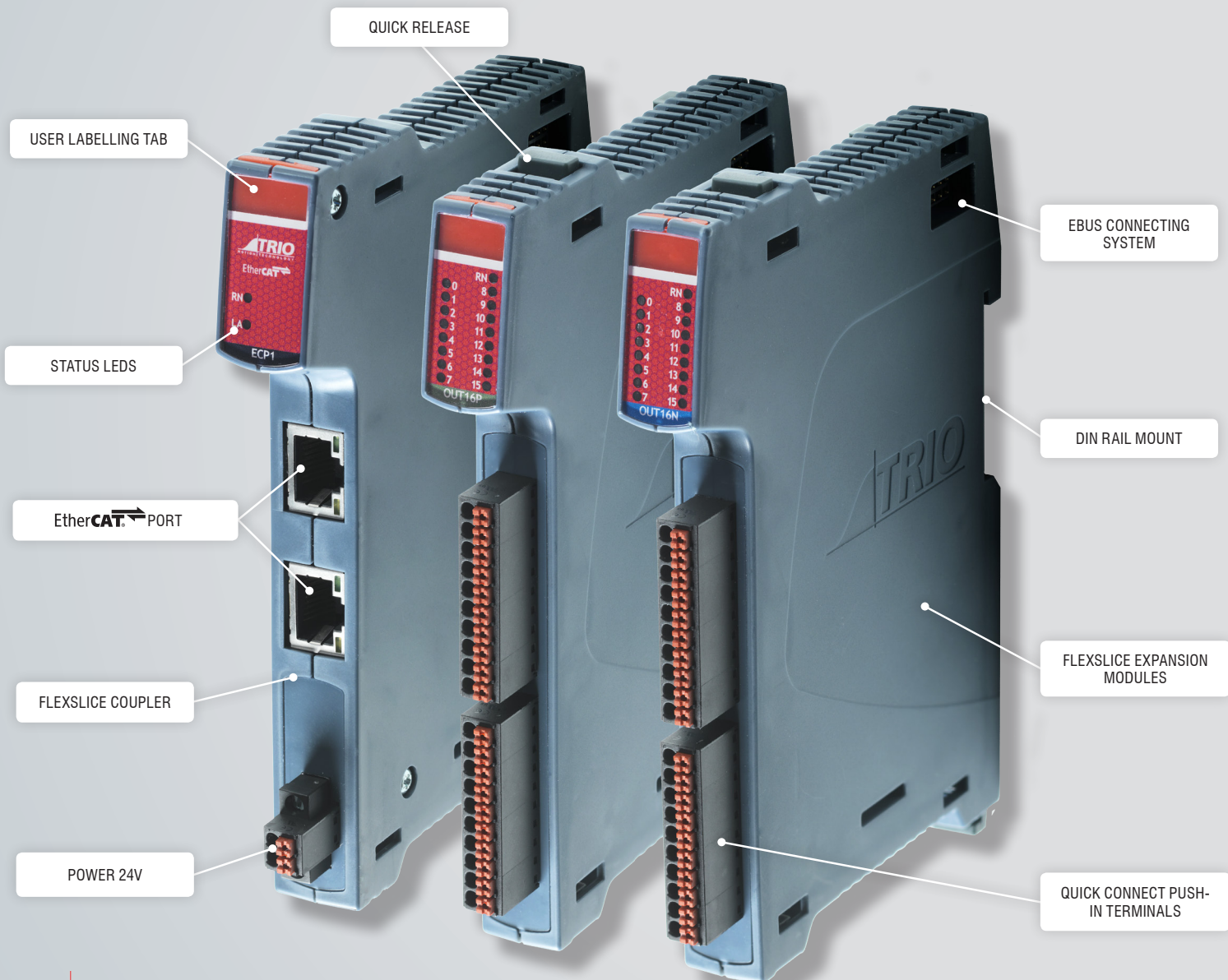
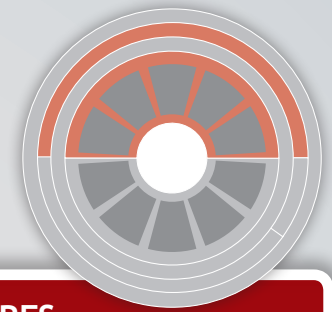

### FEATURES

- ★ Use with Trio or 3<sup>rd</sup> Party EtherCAT Masters
- ★ High Performance, Flexible Topology and Simple Configuration
- ★ Bus Cycle Time Synchronised with *Motion Coordinator* Servo Period
- ★ Bus Coupler Module with 2x RJ45 Ethernet Ports For Ethercat Connection
- ★ Ethercat Protocol Remains Fully Intact Down to Individual Modules Using the E-Bus System
- ★ I/O Functions Tightly Synchronised to Motion Using Ethercat Distributed Clocks
- ★ Automatic Mapping to the *Motion Coordinator* I/O System
- ★ DIN Rail Mounted
- ★ Multiple Practical Push-In Connector Options – No Break Outs Required
- ★ Clip-Together Design With 'Quick Release' Locks For Mechanical Integrity
- ★ User Labelling Facility
- ★ Machine Builder Custom Functionality Options

The EtherCAT Flexslice System is designed to let you do more! It offers fast flexible expansion for motion applications and can be used with Trio or 3rd Party Masters.

Trio's Flexslice input/output modules provide a robust, high speed and flexible solution for both motion control and general automation. EtherCAT cycle times down to 250µsecs are supported and the bus coupler uses EBUS technology to bring all the sub-modules on to the EtherCAT network with no degradation in performance.

The Flexslice system makes available a selection of digital and analogue I/O terminals as well as motion modules with pulse + direction outputs designed for precise positioning of stepper and servo motors via suitable drive technology.

The digital I/O modules have high-speed functionality. In addition, analogue modules and axis modules may be fitted to make a superbly tailored system that can be placed remotely from the master if needed.

All Flexslice modules support automatic addressing with the master to automatically detect and configure the modules on startup. The bus coupler can support up to 16 input/output modules which have a positive mechanical lock and bus connector, making a reliable EBUS connection through the backplane. The complete assembly can be DIN rail mounted.

The Flexslice system begins with the coupler.

The coupler is connected to the network via the upper Ethernet interface. The lower RJ45 socket may be used to connect further EtherCAT devices in the same strand.

In the EtherCAT network, the P366 coupler can be installed in any position in the Ethernet string; making it suitable for operation close to the master or at a remote position.

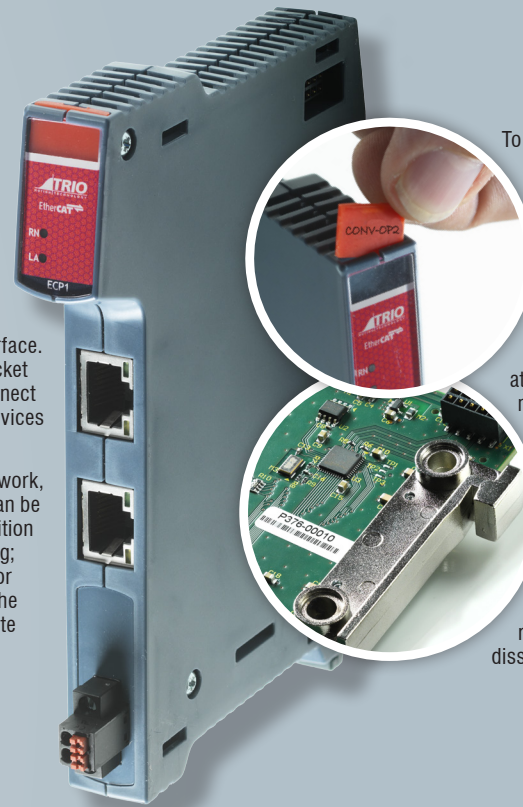

To help with identification, each Flexslice module incorporates a handy removable tab that can be written on. It simply slides in and out of a slot at the top of each module.

The robust metal chassis provides a good earth from the pcb of each module to the DIN rail to reduce noise and dissipate heat.

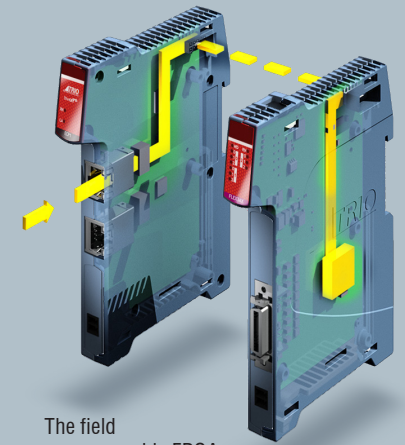

The field programmable FPGA allows customisation of the functionality of some Flexslice Modules using *Motion Perfect v4*. The program can be "locked-down" creating a unique function for a machine builder which protects the functionality from being copied.

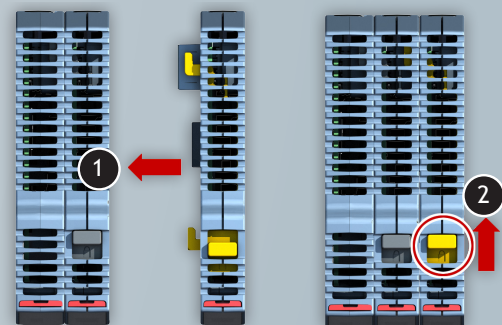
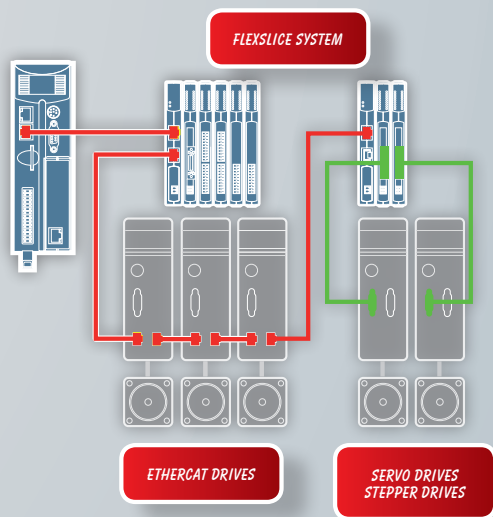

The positive "click-to-lock" mechanism firmly clamps Flexslice modules to each other to form a Flexslice station. Simply push each module together and slide the quick release locks into position.

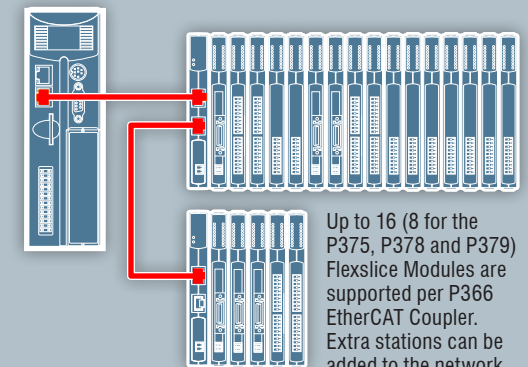

Up to 16 (8 for the P375, P378 and P379) Flexslice Modules are supported per P366 EtherCAT Coupler. Extra stations can be added to the network using the second EtherCAT port.

# Flexslice System Flexible EtherCAT Devices

## P366: ETHERCAT COUPLER

The P366 Flexslice EtherCAT Coupler connects EtherCAT with the EtherCAT slices. One station consists of a P366 Coupler and up to 16 Flexslice EtherCAT modules. The Coupler converts the passing telegrams from Ethernet 100BASE-T to EBUS signal format.

Power supply requirement	24V DC, 0.8A min for full system
EtherCAT Connection	RJ45
Protocol	EtherCAT
Data rate	100 Mbit/s
Dimensions (mm)	17.2w x 147h x 107d
Weight	160g
Network Cable	CAT5e min
Compliance	RoHS, CE and UL

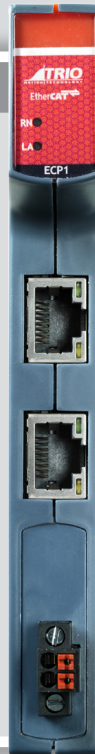

### PRODUCT CODES:

P366	Flexslice EtherCAT Coupler
P371	Flexslice 16-Out PNP
P372	Flexslice 16-In PNP
P375	Flexslice Flex 3-Axis
P376	Flexslice 16-Out NPN
P377	Flexslice 16-In NPN
P378	Flexslice 8 Analogue Outputs
P379	Flexslice 8 Analogue Inputs
P367	Flexslice Thermocouple *
P373	Flexslice 8-In 8-Out*
P374	Flexslice Analogue 2 Servo Axes*

\* Coming soon

## P371: 16-OUT PNP

The P371 digital output Flexslice connects the binary control signals from the *Motion Coordinator* to the machine's output devices at 24V DC. All 16 outputs are current sourcing (PNP) type and have electrical isolation. Outputs and power connection are via 2 x single-row push-in connectors. The Flexslice module indicates the output signal states via LEDs.

Module current consumption (EBUS 5V)	110mA max
Number of Digital Outputs	16 (2 banks of 8)
Power supply requirement	24V (+/-20%) DC
Load type	Resistive, inductive and capacitive
"ON" time	110us (10% to 90%)
"OFF" time	210us (90% to 10%)
Max. Output current	0.5A per channel
Max. Output current	4A per bank of 8 Outputs
Short-Circuit Protection	1.4A typ per output
Over voltage Protection	Yes
Reverse Voltage Protection	Yes



## P372: 16-IN PNP

The P372 digital input Flexslice connects 24V DC signals from devices on the machine to the binary control registers in the *Motion Coordinator*. All 16 inputs are current sinking (PNP) type and have electrical isolation. Inputs and power connection are via 2 x single-row push-in connectors. The Flexslice module indicates the input signal states via LEDs.

Module current consumption (EBUS 5V)	100mA max
Number of Digital Inputs	16 (2 banks of 8)
Power supply requirement	24V (+/-20%) DC
"ON" Voltage threshold	11.2V typ
"OFF" Voltage threshold	10.2V typ
Input current	3.5mA typ
Input filter Cut-off (RC network)	18KHz



## P375: FLEX 3-AXIS

The P375 Flex 3 Axis Module allows up to 3 stepper motors or encoders to be connected to a control system. It supports incremental encoders. If configured for stepper / pulse output an axis can be pulse+direction or quadrature simulated encoder output. A single MDR connector provides a reliable shielded 26 way connector for high speed signals. The P375 is compatible with most high-resolution microstep drives.

Max Step Rate	8MHz pulse count
Step / Pulse Width	Pulse Control or Square Wave
Max Enc Rate	8MHz encoder count
Module current consumption (EBUS 5V)	150mA max
Field Programmable	Yes
Step/Enc Port	MDR Connector 0...5V
Max Axes	3 (software configurable)
WDOG Output	Yes



**EtherCAT®**

### P376: 16-OUT NPN

The P376 digital output Flexslice connects the binary control signals from the *Motion Coordinator* to the machine's output devices, such as relays, contactors, valves, lamps etc. at 24V dc. All 16 outputs are current sinking (NPN) type and have electrical isolation. Outputs and power connection are via 2 x single-row push-in connectors. The Flexslice module indicates the output signal states via LEDs.

Module current consumption (EBUS 5V)	110mA max
Number of Digital Outputs	16 (2 banks of 8)
Power supply requirement	24V (+/-20%) DC
Load type	Resistive, inductive and capacitive
"ON" time	75us (90% to 10%)
"OFF" time (typ)	105us (10% to 90%)
Max. Output current	0.5A per channel
Max. Output current	4A per bank of 8 Outputs
Short-Circuit Protection	3A typ per output
Over voltage Protection	Yes
Reverse Voltage Protection	Yes



### P377: 16-IN NPN

The P377 digital input Flexslice connects 24V dc signals from devices on the machine to the binary control registers in the *Motion Coordinator*. All 16 inputs are current sourcing (NPN) type and have electrical isolation. Inputs and power connection are via 2 x single-row push-in connectors. The Flexslice module indicates the input signal states via LEDs.

Module current consumption (EBUS 5V)	100mA max
Number of Digital Inputs	16 (2 banks of 8)
Power supply requirement	24V (+/-20%) DC
"ON" Voltage threshold	13.7V typ
"OFF" Voltage threshold	14.6V typ
Input current	3.5mA
Input filter Cut-off (RC network)	18KHz



### P378: 8 ANALOGUE OUTPUTS

The P378 Flexslice 8 Analogue Output module has eight programmable voltage range output terminals, each digitised to a resolution of 12 bit. The 8 single ended outputs have a common 0V potential and are brought out to a single push-in connector.

Power Supply	via the EBUS
Module current consumption (EBUS 5V)	200mA max
Signal voltage	-10...+10V; 0...+10V
Signal current	+/-6mA max
Resolution	12 bit
Output impedance	0.5ohm
Number of Analogue Outputs	8



### P379: 8 ANALOGUE INPUTS

The P379 Flexslice 8 Analogue Input module has eight programmable voltage range input terminals, each digitised to a resolution of 12 bit. The 8 single ended inputs have a common 0V potential and are brought out to a single row push-in connector.

Power Supply	via the EBUS
Module current consumption (EBUS 5V)	160mA max
Signal voltage	-10...+10V; 0...+10V
Signal current	0...20mA
Resolution	12 bit
Overvoltage protection	±25V
Number of Inputs	8



### ALL FLEXSLICE MODULES

Connectors	Push-in
Cable length (max)	30m
Dimensions (mm)	15w x 147h x 107d
Weight	145 g
EtherCAT refresh cycle	≥ 125us
Isolation	1KV
Compliance	RoHS and CE

### OVERALL DIMENSIONS

