



Automation for a Changing World

Delta Industrial Automation

2018 Full Range Catalogue

TABLE OF CONTENTS

Milestones

1

About Delta
Delta IABG Profile
Delta IABG Milestones

AC Motor Drive

3

High Performance/Standard Compact Drives ^{New} MH300/MS300	3
Sensorless Vector Control Compact Drives VFD-E/EL	4
Economy Vector Control Drive C200	5
Vector Control Drive C2000	6
Fan/Pump Vector Control Drive CP2000	7
IP55 Fan/Pump Drive ^{New} CFP2000	8
Heavy Duty Vector Control Drive CH2000	9
Textile Vector Control Drive CT2000	10
Elevator Drive VFD-ED	11
Door Control Drive VFD-DD	12
Integrated Elevator Drive IED	13
Hybrid Energy Saving System HES	15
Power Regenerative Unit REG2000	16

Power Quality Solutions

Active Front End AFE2000	17
Static Var Generator SVG2000	17
Active Power Filter APF2000	18

AC Servo Drives and Motors

AC Servo Drives

ASDA-A3 New	19
ASDA-A2	20
ASDA A2-E	23
ASDA-B2	25
ASDA-M	27
Spindle Motor Drive	29
ASDA-S	
IPM Spindle Motor	29
ECMS	

Actuators

Linear Motion Drive	30
ASDA-A2R	
Ironless Linear Motor	30
ECML	
Linear Shaft Motor	31
ECML-S	
Linear Stages	
LU	32
LA-S	33

Gearboxes

Planetary Gearboxes	34
PS/PA	

PC-Based Motion Controllers

PC-Based Motion Controllers (PAC)	35
MH1/MP1	
Delta High-Speed Motion Control System	37
DMCNET	
High-Speed Motion Control System New	39
EtherCAT	

CNC Solutions

Open CNC Solution New	41
NC E	
CNC Solution	42

Robot Controller

Robot Controller with Servo Drive Integrated ASDA-MS	43
---	----

Controller with Human Machine Interfaces

7-inch Controller with Widescreen Handheld HMI HMC07-N411H5C5(A)	45
7-inch Controller with Handheld HMI HMC08-N500S52	45
8-inch Controller with HMI HMC08-N500S52	45

Controller

47

Programmable Logic Controllers

Hot Swappable Mid-range PLC AH500	47
Compact Modular Mid-range PLC AS	51
High Performance PLC DVP-EH3	53
Standard PLC/Analog I/O PLCs DVP-ES2/EX2	54
Advanced Network Type Slim PLC DVP-SE	54
High Performance Slim PLC DVP-SV2	55
Standard Slim PLC DVP-SS2	56
Advanced Slim PLC DVP-SA2	56
Analog I/O Slim PLC DVP-SX2	56
Multi-axis Motion Controllers DVP-10MC/15MC New	57
General Motion Controller DVP-PM	58

Human Machine Interfaces

Advanced Ethernet HMIs New	59
DOP-103WQ (4.3-inch) / DOP-107WV (7-inch) / DOP-110WS (10.1-inch)	
Large-Size HMIs	60
DOP-W105B (10.4-inch) / DOP-W127B (12-inch) / DOP-W157B (15-inch)	
Widescreen HMIs	61
DOP-B03S(E)211 (4.3-inch) / DOP-B07S(E)411 (7-inch) / DOP-B07S(E)415 (7-inch) / DOP-B10S411 (10.1-inch) / DOP-B10S(E)615 (10.1-inch)	
Standard HMIs	62
DOP-B05S111 (5.6-inch) / DOP-B07S(E)515 (7-inch) / DOP-B08S(E)515 (8-inch) / DOP-B10S511 (10.4-inch) / DOP-B10E515 (10.4-inch)	
Functional HMIs	63
DOP-B07PS415 (7-inch Widescreen) / DOP-B07PS515 (7-inch)	
Widescreen Handheld HMI	64
DOP-H07 (7-inch)	

Text Panel HMIs

4-Line Text Panel HMIs	65
TP04G-AL-C / TP04G-AL2 / TP04G-BL-C	
8-Line Text Panel HMI	65
TP08G-BT2	

Touch Panel HMIs with Built-in PLC

7-Inch Touch Panel HMIs with Built-in PLC	66
TP70P-RM0 / TP70P	
4-Line Text Panel HMI with Built-in PLC	66
TP04P	

Sensor / Process Controller / Field Device 67

Sensors

Photoelectric Sensors New	67
PS-R / PS-F / PS-L / PS-M	
Inductive Proximity Sensor	67
IS	
Fiber Amplifier New	68
FA	
Laser Displacement New	68
LD	
Area Sensor New	68
AS	

Rotary Encoders

Rotary Encoders HS/ES/EH	69
-----------------------------	----

Barcode Scanner

Handheld Barcode Scanner New DAH	70
--	----

Temperature Controllers

Advanced Intelligent Temperature Controller DT3	71
Intelligent Temperature Controller DTK	73
Standard Temperature Controller DTA	73
Advanced Temperature Controller DTB	73
Modular Temperature Controller DTC	74
Basic Temperature Controller DTD	74
Multi-Channel Modular Temperature Controller DTE	74

Pressure Sensors /Flow Switch

Standard Multifunction Pressure Sensor DPA	75
Basic Multifunction Pressure Sensor DPB	75
Flow Switch New DFM	75

Timer/Counter/Tachometer/Valve Controllers

Valve Controller DTV	76
Timer/Counter/Tachometer CTA	76

Power Meters

Multifunction Power Meters DPM-C530 / DPM-C520 / DPM-C501L New / DPM-C520W New / DPM-C520I	77
---	----

Machine Vision

79

Machine Vision Systems

DMV2000	79
DMV1000	81

Industrial Power Supply

83

DIN Rail Models

CliQ / CliQ II / CliQ III / CliQ M / Lyte / Chrome / Sync / DVP	83
---	----

Panel Mount Models

PMC / PMF / PMH / PMR / PMT / PMU	84
-----------------------------------	----

Open Frame Models

PJ / PJB / PJT / PJU	84
----------------------	----

Network

85

Industrial Ethernet Solutions

Managed Switches

DVS-328 ^{New} / DVS-110 / DVS-109 / DVS-108	85
--	----

PoE+ Managed Switch

DVS-G512	86
----------	----

Unmanaged Switches

DVS-G005100A / DVS-005 / 008 / 016	87
------------------------------------	----

PoE+ Unmanaged Switches

DVS-G408W01 / DVS-G406W01-2GF	87
-------------------------------	----

SFP Fiber Transceivers

LCP-GbE / LCP-1FE	88
-------------------	----

PoE+ Splitter

DVS-G401	88
----------	----

PoE+ Injector

DVS-G402	88
----------	----

IEEE 802.11 WLAN

DVW-W02W2-E2	89
--------------	----

High-gain Antenna

DVW-ANT	89
---------	----

Industrial 3G Cloud Router

DX-2100	90
---------	----

Industrial Ethernet Cloud Router 90
DX-2300

Industrial 3G/WAN VPN Router 90
DX-3001

Industrial Fieldbus Solutions

BACnet MS/TP Slave Module 91
DVPCM52-SL

PROFIBUS DP Slave Module 91
DVPPF02-SL

Ethernet Master Module 91
DVPEN01-SL

RS-422/485 Master Module 91
DVPCM12-SL

CANopen Master Module 91
DVPCOPM-SL

DeviceNet Master Module 91
DVPDNET-SL

Ethernet Remote I/O Communication Module 92
RTU-EN01

PROFIBUS DP Remote I/O Communication Module 92
RTU-PD01

DeviceNet Remote I/O Communication Module 92
RTU-DNET

RS-485 Remote I/O Communication Module 92
RTU-485

DVP Series Slave Modules (Right-side) 92
DVPCP02-H2/DVPPF01-S/DVPPF02-H2/DVPDT01-S/DVPDT02-H2

USB Converters 93
UC-PRG015-01A/IFD6500/IFD6503/IFD6530

MODBUS Serial Converters 94
IFD8500A/IFD8510A/IFD8520

Industrial Network Converters 94
IFD9502/IFD9503/IFD9506/IFD9507

Industrial Automation Solutions 95

Industrial PC / Equipment IoT Platform / Software 97

Industrial PC DIAV	97
Equipment IoT Platform New DIALink	99
SCADA System DIAView	101
Industrial Energy Management System DIAEnergie	102

Robot 103

Delta Articulated Robots New DRV70L / DRV90L	103
SCARA Robots DRS40L / DRS50L New / DRS60L / DRS60H New / DRS70L New	105

Global Operations 107

About Delta

Delta, founded in 1971, is a global leader in power and thermal management solutions and a major player in several product segments such as industrial automation, displays, and networking. Its mission statement, "To provide innovative, clean and energy-efficient solutions for a better tomorrow," focuses on addressing key environmental issues such as global climate change. As an energy-saving solutions provider with core competencies in power electronics and innovative research and development, Delta's business categories include Power Electronics, Automation, and Infrastructure. Delta has 163 sales offices, 64 R&D centers and 39 manufacturing facilities worldwide.



Throughout its history, Delta has received many global awards and recognition for its business achievements, innovative technologies and dedication to corporate social responsibility. Since 2011, Delta has been selected as a member of the Dow Jones Sustainability™ World Index (DJSI World) for 7 consecutive years. In 2016, Delta was selected out of 5,800 large companies by CDP (formerly the Carbon Disclosure Project) for its Climate Change Leadership Level.

Delta IABG Milestones

1995		1999		2003	
AC Motor Drive (A Series)	Small PLC (DVP-ES Series)	AC Servo Motor and Drive (ASDA-A Series)	Temperature Controller (DTA Series)	Optical Incremental Encoder (ES / EH Series)	
2009		2010		2011	
Pressure Sensor (DPA Series)	Active Front End Unit (AFE2000 Series)	Motion Control Card (PCI Series)	CNC Controller (NC300 Series)	Hybrid Energy Saving System (HES)	
2012		2014			
Machine Vision System (DMV Series)	Programmable Automation Controller (MH1 Series)	Power Meter (DPM Series)	Linear Shaft Motor (ECML-S Series) Linear Stage (LU/LA-S Series)	Photoelectric Sensor (PS-F/PS-R Series) Inductive Proximity Sensor (M12/M18 Series)	
2016					
Compact Modular Mid-range PLC (AS Series)	IIoT Cloud-based Platform (DIACloud)	IIoT Industrial Cloud Routers (DX-2100/2300 Series)	Industrial PCs (DIAV Series)	Planetary Gearboxes (PS Series)	

Delta IABG Profile

- **Mission:** To elevate the living environment through advanced automation technology with value added innovation.
- **Headquarters** in Taoyuan, Taiwan
- **Launched AC motor drives** in 1995
- **Manufacturing and R&D technology centers** in Taoyuan (Taiwan), Taichung (Taiwan), Tainan (Taiwan), Wujiang (China), Shanghai (China), and Hosur (India)
- **Number of employees:** 7,451 (R&D 1,047)



About Delta Industrial Automation

As a world-class industrial automation brand, we are dedicated to the development of AC motor drives, servo and motion control systems, programmable logic controllers, human machine interfaces, machine vision systems, meters and sensors, industrial control and monitoring software, and industrial robots.

Our industrial automation solutions extend to a broad range of industry applications, including electronics, textiles, food, pharmacy, rubber and plastics, packaging, printing, woodworking, and machine tools. We integrate our automation products, equipment networking, system software, IoT technology, and big data analysis to build innovative and reliable smart, green factory automation solutions for global customers, and to realize our promise of “Automation for a Changing World”.

2004		2005		2006		2008	
Human Machine Interface (DOP-A Series) 		AC Servo Motor and Drive (ECMA/ASDA-B Series) 		Time/Counter/Tachometer (CTA Series) 		Industrial Power Supply (PMC/CliQ Series) 	
2012							
Integrated Elevator Drive (IED Series) 		Unmanaged Industrial Ethernet Switch (DVS Series) 		High Performance Mid-range PLC (AH500 Series) 		Controller with Human Machine Interface (HMC Series) 	
2015				2016			
Robot Controller with Servo Drive Integrated (ASDA-MS Series) 		SCARA Robot (DRS40L Series) 		Industrial Energy Management System (DIAEnergie) SCADA System (DIAView) 		Articulated Robots (DRV70L/DRV90L Series) 	
2017							
Flow Switch (DFM Series) 		Laser Displacement (PS Series) 		Barcode Scanner (PS Series) 		Area Sensor (PS Series) 	



High Performance / Standard Compact Drive New

MH300/MS300

Compact-designed Powerful Multifunction Drives

Optimized Space Utilization

- Compact design with up to 40% size reduction compared to existing models

Outstanding Drive Performance

- Support both induction and permanent magnet motors
- MS300 series: supports open-loop control
- MH300 series: supports open-loop/closed-loop control

Strong System Support

- High speed models: support up to 1500 Hz (MS300)/ 2000 Hz (MH300) output frequency under open-loop control
- Built-in PLC with 2k steps (MS300); 5k steps (MH300) program capacity
- Built-in braking choppers for the entire series
- Various communications: EtherCAT, PROFIBUS DP, DeviceNet, MODBUS TCP, EtherNet/IP, CANopen



High Safety, Stability and Reliability

- Built-in STO (SIL2/PLd) safety function and safety measures for sudden power outages
- Enhanced 100% PCBs conformal coating; compliant with IEC 60721-3-3 class 3C2
- Extended key components lifetime

Easy to Install, Easy to Use

- A user friendly and removable 5-digital LED keypad for the MS300 series; LCD keypad equipped with quick setting wheel dial for the MH300 series
- Macro function, quick parameter setting and duplication
- Built-in USB port for monitoring



Power Range	0.2 kW 0.25 HP	0.4 kW 0.5 HP	0.75 kW 1 HP	1.5 kW 2 HP	2.2 kW 3 HP	3.7 kW 5 HP	5.5 kW 7.5 HP	7.5 kW 10 HP	11 kW 15 HP	15 kW 20 HP	18.5 kW 25 HP	22 kW 30 HP
Standard Model MH300 & MS300 0~599 Hz	150V/1-phase											
	230V/1-phase											
	230V/3-phase											
	460V/3-phase											
High Speed Model MH300: 0~2000 Hz MS300: 0~1500 Hz				230V/1-phase								
					230V/3-phase							
	460V/3-phase											

Applications

MS300: Machine tools, textile machines, woodworking machines, packaging machines, electronics, fans, pumps and air compressors

MH300: Machine tools, textile machines, woodworking machines, rubber & plastic machines and cranes

Sensorless Vector Control Compact Drive

VFD-E/EL

Small Size with Multifunctions



- Optional extension modules for more flexible applications (High speed fieldbus, braking modules, I/O cards and PG cards for VFD-E Series)
- Modular fan design for easy maintenance and replacement
- Built-in EMC filter for 230V single-phase and 460V three-phase models to effectively minimize the electromagnetic interference
- Built-in RFI Switch for noise suppression (all models)
- Built-in PLC with 500 steps program capacity (VFD-E Series)
- Support common DC BUS. The regenerative braking power is shared by parallel connected AC motor drives to enhance the stability of the DC BUS voltage
- Support side-by-side installation and DIN-rail mounting
- Built-in PID feedback control, special functions for constant pressure pump
- Built-in RS-485, compatible with MODBUS communication (baud rate up to 38,400 bps)
- Two models for selection: CANopen drive with CANopen communication protocol, and the plate drive with no fan and colling fins installed



Power Range	0.2 kW 0.25 HP	0.4 kW 0.5 HP	0.75 kW 1 HP	1.5 kW 2 HP	2.2 kW 3 HP	3.7 kW 5 HP	5.5 kW 7.5 HP	7.5 kW 10 HP	11 kW 15 HP	15 kW 20 HP	18.5 kW 25 HP	22 kW 30 HP
VFD-E	115V/1-phase											
	230V/1-phase											
	230V/3-phase											
	460V/3-phase											
VFD-EL	115V/1-phase											
	230V/1-phase											
	230V/3-phase											
	460V/3-phase											

Applications

Food packaging machines, conveyor equipment, textile machines, woodworking machines, fans and water pumps

Economy Vector Control Drive

C200

High Speed Frequency Output

- Support both induction and permanent magnet motors
- Built-in PLC with 5k steps program capacity
- Special PCB coating and ventilation design for enhanced environment tolerance
- Flange mount design for Frame A and removable panel to facilitate installation process
- Built-in pulse input terminal with encoder for closed-loop control
- Built-in CANopen and RS-485 (MODBUS) communication



Power Range	0.4 kW 0.5 HP	0.75 kW 1 HP	1.5 kW 2 HP	2.2 kW 3 HP	3.7 kW 5 HP	4 kW 5 HP	5.5 kW 7.5 HP	7.5 kW 10 HP
C200	230V/1-phase							
	230V/3-phase							
	460V/3-phase							

Applications

Food packaging machines, conveyor equipment, textile machines, woodworking machines, fans and water pumps



Vector Control Drive

C2000

For Universal Drive Controls

- Support both induction and permanent magnet motors
- Field oriented vector control
- Wide power range for different industry needs
- Built-in PLC with 10k steps program capacity
- Long service life design
- Enhanced protections and adaptation to industrial environments
- Modular design for easy maintenance and extensions
- Built-in MODBUS communication and provides for optional communication cards: PROFIBUS DP, DeviceNet, MODBUS TCP, EtherNet/IP, EtherCAT and CANopen



Power Range	0.75~3.7 kW 1~5 HP	5.5~18.5 kW 7.5~25 HP	22~37 kW 30~50 HP	45~90 kW 60~125 HP	110~185 kW 150~250 HP	220~450 kW 300~600 HP	560~630 kW 715~850 HP
C2000	230V/3-phase						
	460V/3-phase						
	575V/3-phase						
					690V/3-phase		

Applications

Printing machines, extruders, calender machines, paper machines, compressors and wire drawing machines



Fan/Pump Vector Control Drive

CP2000

Excellent for Large Power Fans and Pumps Applications



- Built-in BACnet and RS-485 (MODBUS) communication protocols
- Enhanced conformal coating on PCBs for superior durability in critical environments
- Fire mode and Bypass mode: continuous pressure output to extract smoke when a fire accident or other emergencies occur
- Quick setting functions to support self-defined parameter groups and parameter duplication for fast and easy installation
- Various modes for fans/pumps applications including PID control, sleep/wake up functions, flying start and frequency-hopping functions
- Built-in LCD keypad is easy-to-use, and the TPEditor software allows users to customize the main page screen
- Multi-pumps synchronous control of up to 8 motors at one time, fixed amount and fixed time circulation control. Relay expansion card is optional
- Built-in PLC with 10k steps program capacity and Real Time Clock
- Optional communication cards: PROFIBUS DP, DeviceNet, MODBUS TCP, EtherNet/IP and CANopen

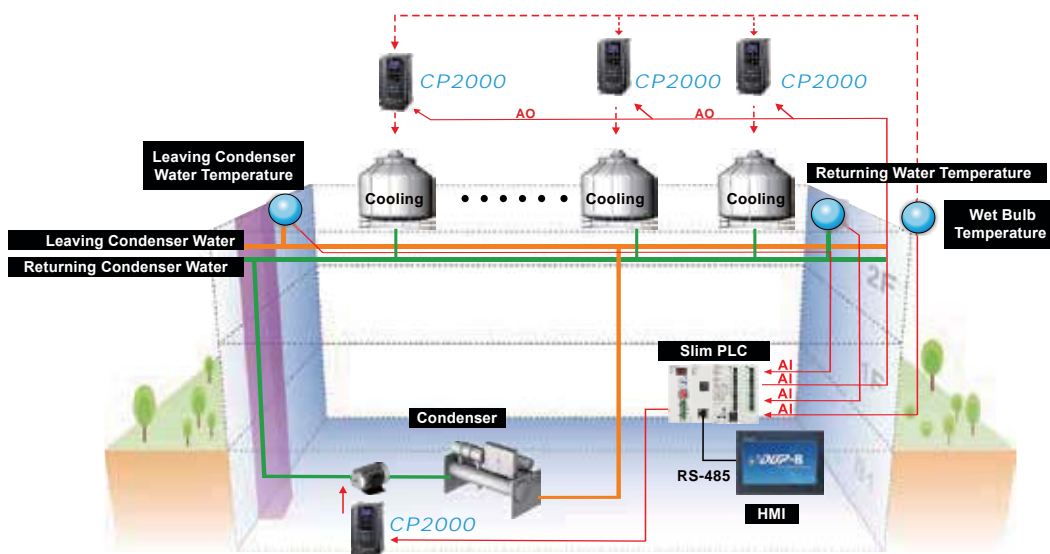

Power Range	0.75 ~ 3.7 kW 1 ~ 5 HP	5.5 ~ 18.5 kW 7.5 ~ 25 HP	22 ~ 37 kW 30 ~ 50 HP	45 ~ 90 kW 60 ~ 125 HP	110 ~ 185 kW 150 ~ 250 HP	220 ~ 450 kW 300 ~ 600 HP	560 ~ 630 kW 715 ~ 850 HP
CP2000	230 V/3-phase						
	460 V/3-phase						
	575 V/3-phase						
	690 V/3-phase						

Applications

Factory automation, HVAC, fans and pumps

IP55 Fan & Pump Drive New

CFP2000

For HVAC, Fans and Pumps Applications

- IP55 and IP41 enclosure protections
- Built-in mains switch option for the IP55 models
- Built-in Safe Torque Off (STO) SIL2 function
- Built-in EMC filter; IEC61800-3 C2, C1 standard
- Built-in DC reactor effectively reduces the harmonic distortion; IEC61000-3-12 standard
- Enhanced PCB (Printed Circuit Board) conformal coating improves drive durability; Class 3C3 standard
- 2 sets of PID controller functions
- Built-in PLC with 10k steps program capacity and Real Time Clock (RTC)
- Built-in MODBUS and BACnet MS/TP communication
- Optional communication cards: PROFIBUS DP, DeviceNet, MODBUS TCP, EtherNet/IP, CANopen
- Built-in Quick Start function and application groups to simplify the installation and setup



Power Range	0.75 ~ 5.5 kW 1 ~ 7.5 HP	11 ~ 22 kW 15 ~ 30 HP	30 ~ 37 kW 40 ~ 50 HP	45 ~ 55 kW 60 ~ 75 HP	75 ~ 90 kW 100 ~ 125 HP
CFP2000	380 to 480V/3-phase				

Applications



Fans



Chiller



Water treatment

Heavy Duty Vector Control Drive

CH2000

Large Overload Capability Excellent for Impact Loading Applications

- Fast response to impact loads
- Super Heavy Duty (SHD) setting for high overload capability: 150% of rated current for 60sec and 200% of rated current for 3sec
- Large starting torque: above 200% at 0.5Hz, and 200% at 0Hz in FOC+PG mode
- Support both induction and permanent magnet motors
- Various crane functions for high operation performance
- Modular design: easy installation and maintenance
- Built-in PLC with 10k steps program capacity
- Built-in MODBUS communication
- Optional communication cards: PROFIBUS DP, DeviceNet, MODBUS TCP, EtherNet/IP, EtherCAT and CANopen



Advanced Crane Functions

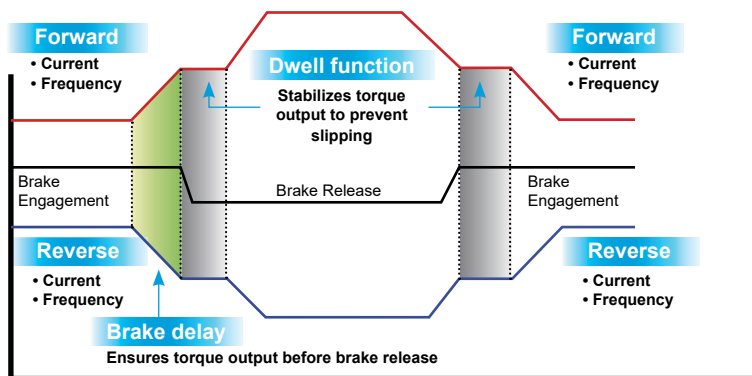

▲ Mechanical Brake Control

8 independent brake control settings for different criteria. High flexibility to meet complex application needs and to ensure operation safety

▲ Advanced Crane Time Sequence

Brake delay and dwell function for smooth operation

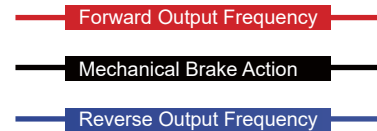

Light Load Acceleration

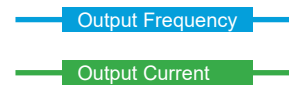
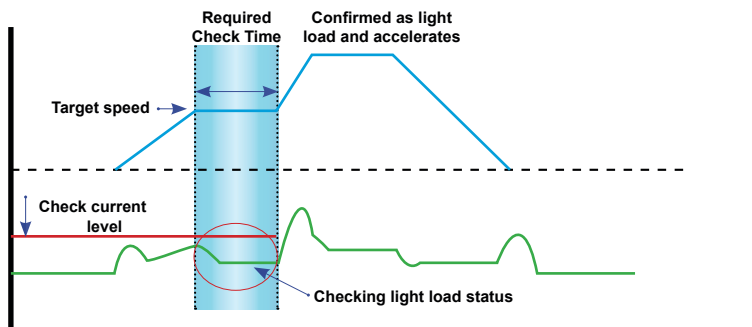

Applications

Machine tools, punching machines, cranes and hoists



Power Range	0.75 ~ 3.7 kW 1 ~ 5 HP	5.5 ~ 18.5 kW 7.5 ~ 25 HP	22 ~ 37 kW 30 ~ 50 HP	45 ~ 75 kW 60 ~ 100 HP	90 ~ 185 kW 125 ~ 250 HP	220 ~ 280 kW 300 ~ 375 HP
CH2000	230V/3-phase					
	460V/3-phase					

Textile Vector Control Drive

CT2000

Highly Flexible Flange Mount and Wall Mount Methods

- Fanless design with highly effective heat sink to prevent fiber and dust from clogging or entering the drive, solving overheating problems^(*)
- Flange mount installation to enhance system safety and stability, providing excellent heat dissipation performance^(*)
- Support external fan connection (optional)^(*)
- Wall mount installation model with an enlarged fan^(**)
- Deceleration Energy Backup (DEB) function for smooth motor deceleration control
- Support both induction and permanent magnet motors
- Common DC BUS design
- Built-in PLC with 10k steps program capacity and RS-485 with MODBUS communication
- Optional communication cards are available upon request

*1: For model names ending with code A or B

*2: For model names ending with code C



Flange Mount



Wall Mount



Power Range	11 kW	15 kW	18.5 kW	22 kW	30 kW	37 kW	45 kW	55 kW	75 kW	90 kW
CT2000	460 V/3-phase									

Applications

Textile machines and all textile applications that require flange mount or wall mount method.

* Flange mount: Please refer to the CT2000 user manual for airway design requirements before installing the drive



Elevator Drive

VFD-ED

Excellent Time Sequence Control for Smooth Rides

- Support both induction and permanent magnet motors
- Precise control of S curve performs smooth start and stop for a comfortable ride
- Optional PG feedback cards (for ABZ & Heidenhain encoder)
- Advanced field oriented vector control
- Automatic torque compensation function to prevent elevator from slipping or vibrating
- Emergency operation is enabled using UPS or battery set when power outage occurs
- Support both wall-mount and embedded installation methods
- Built-in LED digital keypad
- 4 relay output and 2 multi-function digital signal output terminals (MO)
- 2 analog signal input (AI) and 2 analog signal output (AO)
- 1 CANopen and 2 RS-485 with MODBUS communication



Emergency Operation

- Support single phase 230VAC Uninterrupted Power System (UPS)
- Automatically determine the light load operation direction when a power outage occurs

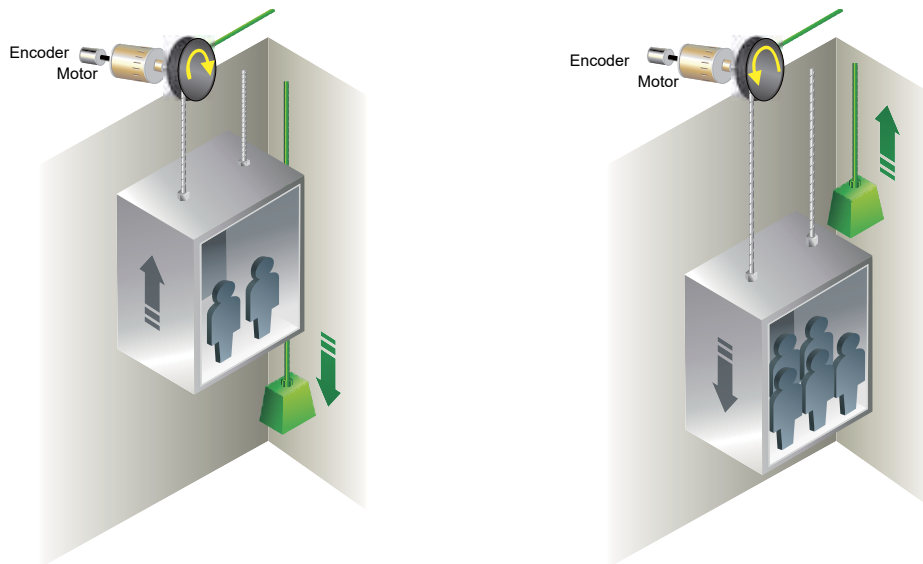

CE EAC  (UL: does not include VFD22ED21S and VFD037ED21S models)

Power Range	2.2 kW 3 HP	3.7 kW 5 HP	4 kW * 5 HP	5.5 kW 7.5 HP	7.5 kW 10 HP	11 kW 15 HP	15 kW 20 HP	18.5 kW 25 HP	22 kW 30 HP	30 kW 40 HP	37 kW 50 HP	45 kW 60 HP	55 kW 75 HP	75 kW 100 HP
ED	230V/1-phase													
	230V/3-phase													
	460V/3-phase													

*Minimum Power Range of the 460V model is 4kW

Door Control Drive

VFD-DD

Door Control Solution

■ Compact and Thin Design

55mm

■ Safety Switch

■ Removable Terminal Blocks



■ Built-in Digital Keypad

■ Distance Control Mode

■ Speed Control Mode

■ Multi-step Speed Control Mode

- Simplified elevator door control system
- Support both induction and permanent magnet motors
- Easy to install with I/O input/output design
- Various protection functions ensure passenger safety
- Auto-tuning of door width

- Auto-positioning when power is applied
- Smooth door re-open / re-close curve
- Demo mode
- Support elevator door obstruction detection

Optional Motors

ECMD-B91207MS

ECMD-B91608MS

ECMD-B81610MS



Applications

Elevator doors

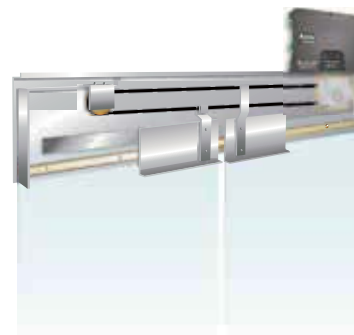

Power Range	0.2 kW 0.25 HP	0.4 kW 0.5 HP
VFD-DD	230 V/1-phase	



Integrated Elevator Drive

IED

Integrated Drive and Control to Save Installation Space

Control

- High-efficiency group control function capable of controlling multiple elevators without the need of additional control cards
- Various operation modes including demo mode; attendant service mode and time-based modes
- Single and double door elevator applications
- Max. 48 floors

Design

- Compact design, suitable for limited installation spaces
- Modular design of fans and capacitors for easy replacement and maintenance
- A small-size LED keypad allows users to check and set the drive control

Drive

- Support induction and permanent magnet motors
- Emergency Power Supply (EPS) function
- Dual safety protection functions. All time output phase loss check and confirms torque output before releasing mechanical brake

Tune

- Auto-learning hoistway and auto floor height detection
- Auto-tuning motor parameters without load disconnection
- PC software monitors motor operation status

Energy Saving

- Power regeneration function available when installed with Delta's Active Front End (AFE2000 Series) or Power Regenerative Unit (REG2000 Series)
- Scheduled lighting and air circulation time function for the elevator car
- Standby mode to save energy

Efficiency

- Direct stop: multi-speed control to provide a comfortable ride with higher efficiency
- Peak hour operation: improves peak hour operation efficiency
- Full-load bypass operation: arrives at designated floor without stopping



One drive for all control needs

Optional

External Digital Keypad

- Controller setting
- Drive setting
- Parameter copy



CE EAC

Power Range	2.2 kW 3 HP	3.7 kW 5 HP	4 kW 5 HP	5.5 kW 7.5 HP	7.5 kW 10 HP	11 kW 15 HP	15 kW 20 HP	18.5 kW 25 HP	22 kW 30 HP	30 kW 40 HP	37 kW 50 HP	45 kW 60 HP	55 kW 75 HP	75 kW 100 HP
IED	230V/1-phase													
	230V/3-phase													
	460V/3-phase													

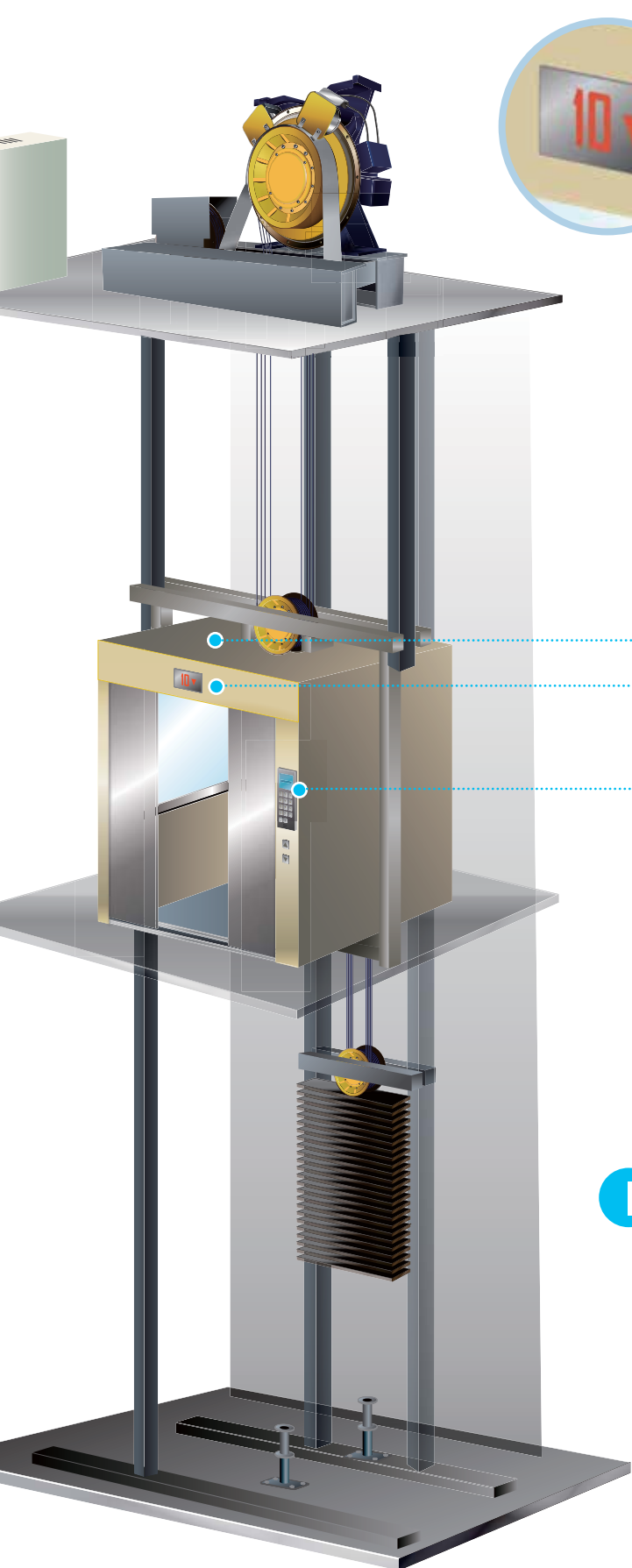

Floor Display Board

- Vertical matrix display board - Standard Type

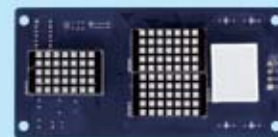

- Vertical/Horizontal matrix display board - Standard Type



Integrated Cartop and Button Board

- Integrated cartop and button board



- Button extension board



PC Software

USB port facilitates program upload/download and tuning process

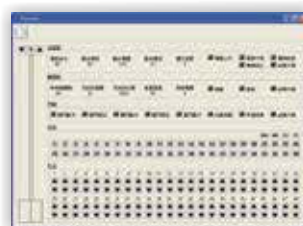

Hybrid Energy Saving System

HES

Energy Saving for Injection Molding Machine

- **Superior Energy-Saving Outcomes:** 40% less energy consumption compared to variable pump hydraulic systems; 60% less energy consumption compared to traditional quantitative pump hydraulic systems
- **Low Oil Temperature:** oil temperature decreased by 5°C to 10°C, saving costs on oil cooler
- **Reduce Oil Usage:** 50% to 60% oil usage savings and a 50% smaller oil tank
- **High Duplication Accuracy:** Precise flow and pressure control featuring duplication of products with less than 0.09% difference
- **Long Holding Pressure:** Keep mold halves securely closed for a longer period for thick plastic products formation
- **Fast Frequency Response:** Delta HES with permanent magnet servo motor (PMSM) speeds up frequency response to 50 ms
- **Suitable for Harsh Environments:** Resolver is resistant to earthquakes, oil and dust
- **Easy to Refurbish Old Machines:** Analog command 0~10V and linear correction (3 points), no need to replace the computer
- **Flow Convergence:** Saves cost on tubes, large flow capacity, and outstanding energy-saving performance



Power Consumption Curve of the Injection Molding Process

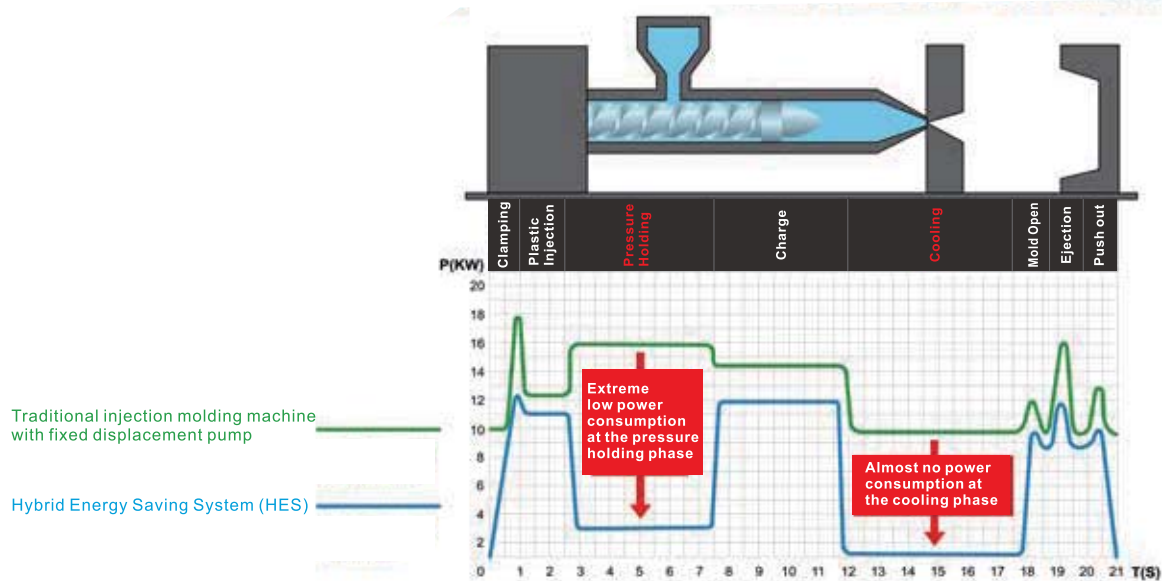

Power Range	50 L/min	63 L/min	80 L/min	100 L/min	125 L/min	160 L/min	200 L/min	250 L/min	320 L/min	
HES	230V/3-phase									
	460V/3-phase									

Applications

Injection molding machines, bottle blowing machines, pipe bending machines, bending machines and other hydraulic equipment

Power Regenerative Unit

REG2000

Replaces Traditional Brake Resistor and Features Power Regeneration

- Compact design with reactor included and easy to install
- Outstanding energy-saving performance with more than 95% power regeneration efficiency
- Replace traditional brake resistors to reduce the generation of heat
- Improve motor braking capability from 125% to 150%
- Built-in RS-485 (MODBUS) communication and real-time monitoring of energy-saving performance and cost
- Compatible with the drives and servo drives that have a DC terminal
- Support parallel connections for large power applications
- Optional communication cards: ⁽¹⁾ MODBUS TCP, EtherNet/IP, CANopen, PROFIBUS DP and DeviceNet

* Please contact Delta Industrial Automation

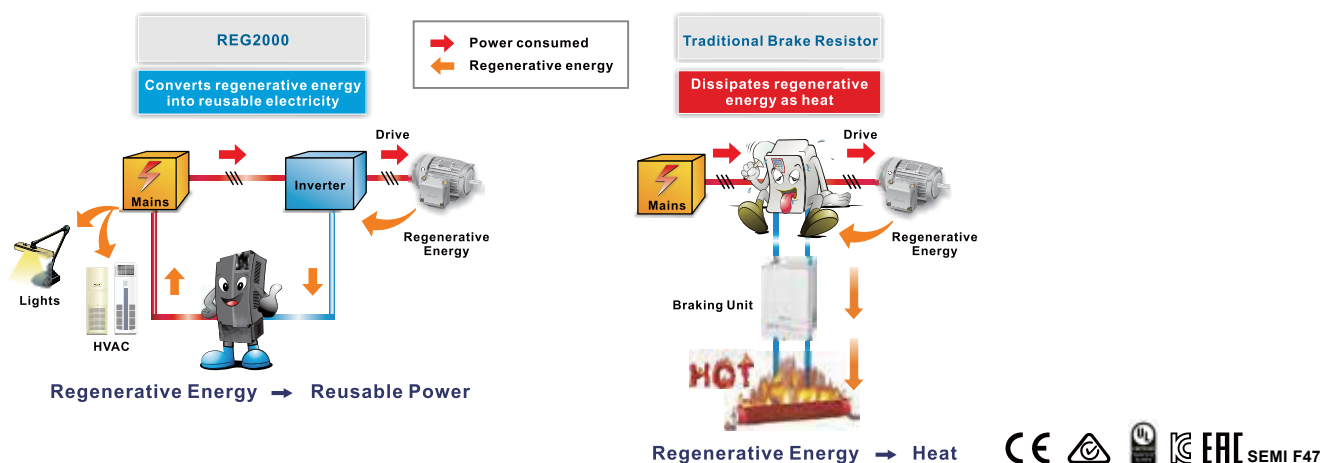

Power Range	7.5 kW	11 kW	15 kW	18.5 kW	22 kW	30 kW	37 kW	45 kW	55 kW
REG2000	230V/3-phase								
	460V/3-phase								

Applications

Large-inertia load applications: centrifuge equipment, industrial laundries, roving machines and more

4-quadrant load applications: elevators, cranes, pumpjacks and more

Long-term energy feedback applications: printing machines, escalators and more

Quick braking applications: machine tools, bag making machines, auto storage and retrieval systems, press machines and more



Escalators



Elevators



Tension Controls

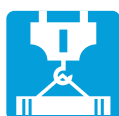

Cranes



Centrifuge Equipment



Press Machines



Industrial Laundries



Machine Tools

Active Front End

AFE2000

The Best Energy Saving Device with AC Motor Drives

- More than 95% power regeneration efficiency
- Improve power factor to more than 99% with input current THD $\leq 5\%$
- Realize 4-quadrant operation with variable frequencies and speed control when applied with AC motor drives
- Maintain constant DC BUS voltage and current when the voltage provided by the mains is unstable
- Supports all kinds of fieldbus for real time power status monitoring and control*



CANopen

DeviceNet

MODBUS TCP

EtherNet/IP

*Available from Delta upon request



EAC

Power Range	7.5 kW 10 HP	15 kW 20 HP	22 kW 30 HP	37 kW 50 HP	45 kW 60 HP	75 kW 100 HP
AFE2000	230 V 3-phase					
	460 V 3-phase					

Applications

Large-inertia loads applications: centrifuge equipment, dewatering machines and roving machines

4-quadrant loads applications: elevators, cranes and pumpjacks (oil extraction machines)

Quick braking applications: machine tools, bag making machines, auto storage and retrieval systems, and lathes

Power quality improvement: semiconductor and panel industries

Long energy feedback time applications: wind power, water power, steel printing and paper making machinery (winding equipment)

Static Var Generator

SVG2000

Comprehensive Reactive Power Compensation to Improve Power Efficiency

- Compensates both leading and lagging reactive current; improves power factor to 0.99
- Adopts special Delta power supply modules to provide a wide range application from 220 V~480 V and 525 V~690 V
- Modular design of fan, power, drive, control and reactor modules
- 7" touch screen TFT LCE expression in 65,536 colors

Capacity	300 k VAR	500 k VAR
SVG2000	220 V~480 V/3-phase	
	525 V~690 V/3-phase	

Applications

A new solution to replace traditional phase-leading capacitors, applicable to the power distribution systems of industry, infrastructure, commercial buildings and homes



Active Power Filter

APF2000

For Power Quality Improvement

- Filter the 2nd to 50th order harmonics with efficiency of more than 90%. IEEE519 standard
- Full response speed faster than 20ms
- Selection to compensate either harmonic wave or reactive power, or compensate both at the same time
- Modular design of fan, power, drive control and reactor modules
- 7" touch screen TFT LCD expression in 65,536 colors
- Compact design: the 300A model only measured 600W x 800D x 2200H (mm)
- Parallel connection of multiple units to expand total capacity
- Built-in RS-485 communication and provides various communication and fieldbus card options



Concept

An active power filter is a large power electrical device that monitors the three-phase current in real time and provides an equally opposite phase to relevant devices to filter out the harmonics. It is parallel connected to the grid and uses a current transformer to inspect the 3-phase current waveform and obtain the required compensation data of harmonic current and reactive power. The active power filter will then inject an equally opposite current input to the power system for harmonic filtering results. In addition, the active power filter can also create phase that complements the leading and lagging reactive current. It effectively improves the power factor of the grid and provides compensation to the reactive power.

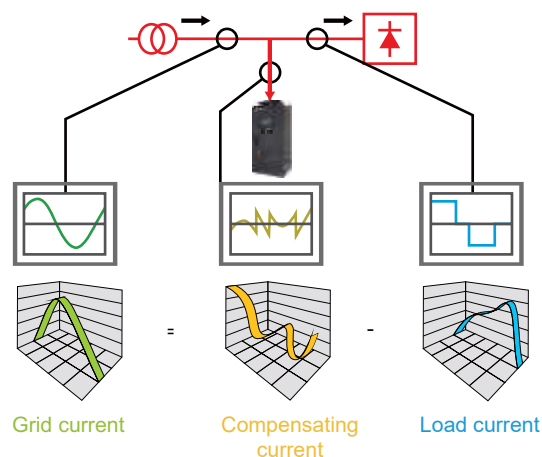

Capacity	50 A	100 A	200 A	300 A
APF2000	200 V ~ 480 V/3-phase			

Applications

Metallurgy and petrochemicals industries:

rectifier, converter, rolling mill, electric arc furnace, medium frequency furnace and inverter

Chemical and electrolysis industries:

rectifier, calcium carbide furnace, electric soldering and inverter

Mechanical industries:

rectifier, rolling mill, inverter, electric arc equipment

Metal, paper, plastic processing and textile industries:

rectifier, rolling mill, inverter, electric arc furnace and electric furnace

Transportation industries:

the rectifier and the inverter of electric vehicles, electric motorcycles and metro systems

Automobile manufacturing industries:

soldering equipment, car painting equipment, battery charger and inverter

Telecommunication, medical and construction industries:

Server station, EPS, UPE, converter, charger and inverter



AC Servo Drive & Motor New

ASDA-A3

24-bit Absolute Type Encoder

3.1 kHz Bandwidth

Advanced Motion Control Functions Inside



3.1 kHz Bandwidth

- Higher responsiveness and shorter settling time increases productivity

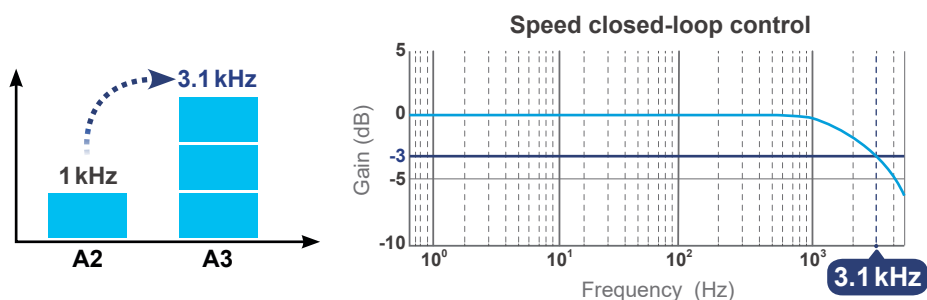

24-bit Absolute Type Encoder

- Positioning precision is enhanced by the 16,777,216 pulses/turn encoder
- The speed variance in low speed is reduced.
- Absolute type encoder helps to keep the motor's position when the power is off

16,777,216 pulses
for one single turn

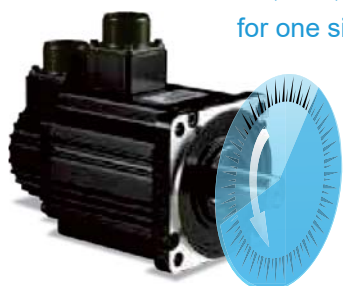

46,603 pulses for one degree

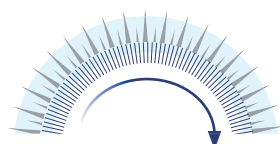

Advanced Motion Control Functions

- 99 sophisticated motion commands and segments allowed
- Graphical user interface offers simple setup and programming
- Arithmetic operation and condition jump commands are added
- General motion functions like homing, position, speed, superimposition, blending, on-the-fly change motion commands and E-CAM functions are available

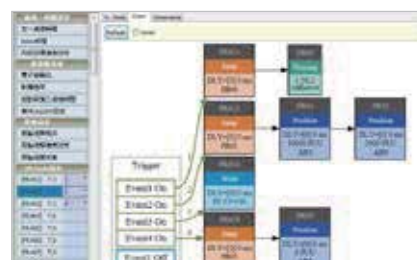

Low Frequency Vibration Suppression Function

- Keeps the machining process stable when mechanisms with higher elasticity such as a belt or a swing arm are applied

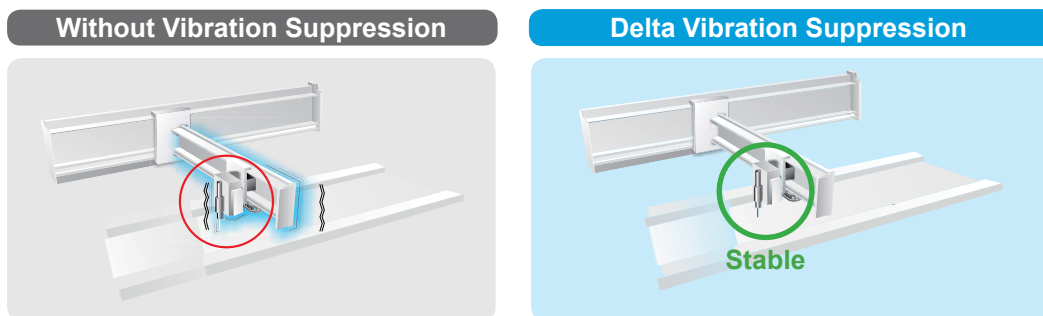

Auto-Tuning Function

- This function will optimize machine performance with less tuning effort and with simple setup procedures via panel keypad or software

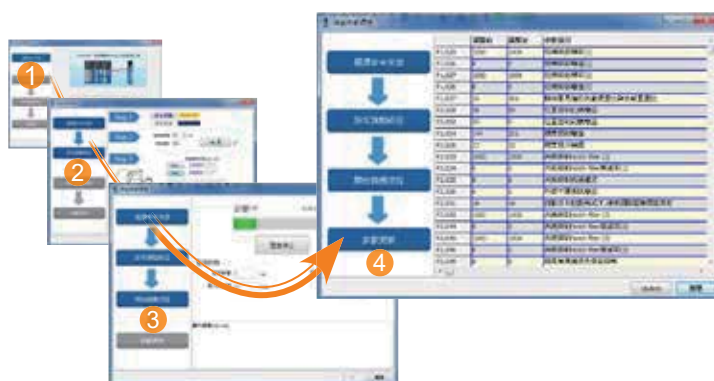

Smart and Intuitive Software Interface

- Tree-view index window with organized list and collapsible menu helps to access functions easily
- Intuitive user interface provides set up functions and parameters with efficiency and accuracy

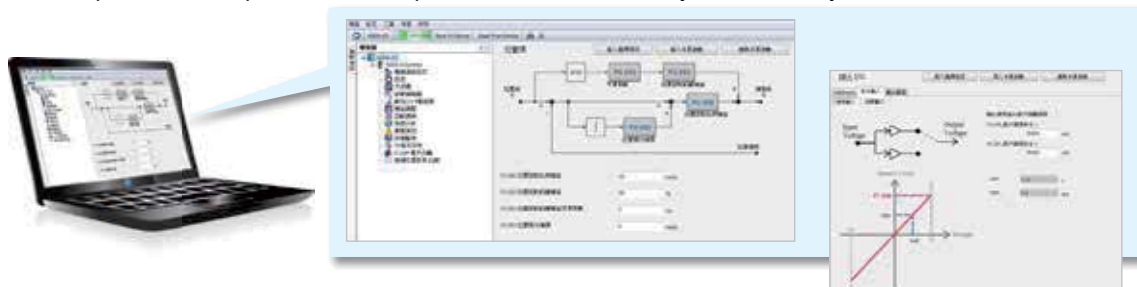

Compact Size Design

- ASDA-A3 is 20% smaller than A2 in dimensions, which requires less installation space

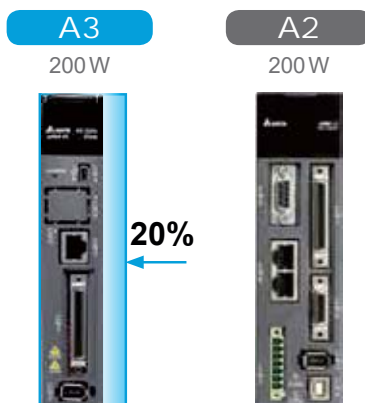

Servo motor shorter in length

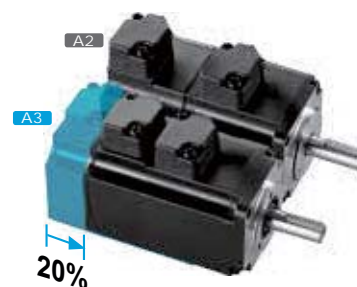

Applications

Machine tools, electronic assembly or detection equipment, industrial robots, packaging, labeling, semiconductor and textile equipment

AC Servo Drive & Motor

ASDA-A2

Implements 20-bit (1,280,000 p/rev) superior resolution encoder as a standard



Built-in Motion Control Functions

- Electronic Cam (E-CAM) function for mark tracing, positioning, synchronous control applications. 720 points max. for E-CAM outline
- High-speed Capture and Compare function for position latch and detection. Max. 800 records can be stored in the memory
- Built-in gantry control algorithm

High Precision, High Performance Servo Motors

- Supports incremental type and absolute type encoders
- Incremental type encoder provides up to 1,280,000 p/rev resolution for high-precision positioning

Full-Closed Loop Control (Accuracy of positioning guaranteed)

- Direct signal transmission through CN5 port to perform full-closed function
- Reduces the effect of backlash and flexibility from the machine and ensures the accuracy of positioning

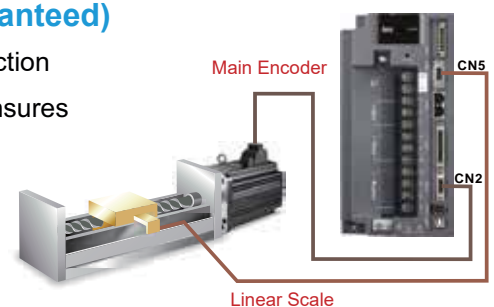
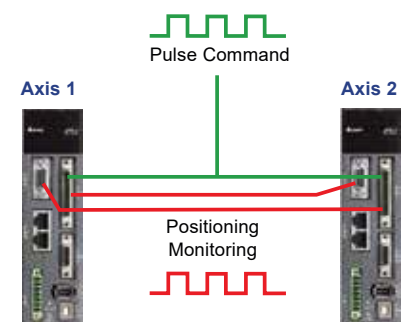

Versatile PR mode

- 64 procedures can be applied for various and multiple points continuous motion movements
- 35 Homing modes/ Jump mode/Write parameter mode/Speed mode/Position mode

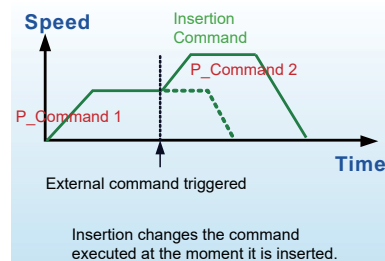
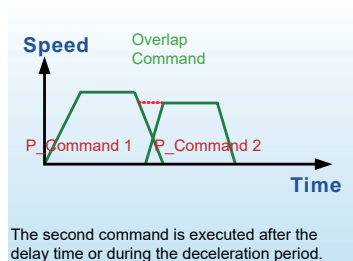
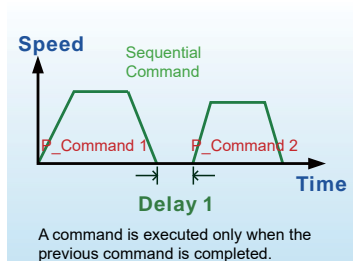

Basic Features

- Input voltage: 200 V_{AC} ~ 230 V_{AC}, 0.1 kW ~ 15 kW, 1-phase / 3-phase, or 3-phase
- Input voltage: 400 V_{AC}, 0.4 kW ~ 15 kW, 3-phase
- Up to 1 kHz bandwidth for high speed and high precision applications
- Supports CANopen, DMCNET, EtherCAT communication protocols
- A2-E model is equipped with Safe Torque Off function (STO) complying with the international standard IEC61800-5-2

	Type	RS-485 (CN3)	Full-Closed Control (CN5) ^{*1}	Extension Port for Digital Input (CN7)	PR Parameters ^{*2}	E-CAM ^{*3}	EtherCAT ^{*4}	CANpen	DMCNET	Analog Voltage Control	Pulse Input Port
Standard Model	L	O	O	X	O	X	X	X	X	O	O
	U	O	O	O	O	O	X	X	X	O	O
Network Model	E	X	O	O	O	O	O	X	X	X	X
	F	O	O	X	O	X	X	X	O	X	X
	M	O	O	X	O	O	X	O	X	O	O

*1. In PR mode, only A2-F supports full-closed control function.

*2. PR parameters can be read and written through communication by DMCNET only.

*3. E-CAM function can only be used in PR mode.

*4. For information about ASDA A2-E EtherCAT interface servo drive, please refer to the ASDA A2-E brochure.

Applications

Precise motion control applications, food packaging machines, filling and bottling equipment, labeling machines, feeding machines, TFT LCD cutting machines, IC packaging machines, injection processing equipment, lathes, electric discharge machines (EDM), woodworking machines, wire cutting machines, printing machines, textile equipment



Food Packaging Machines



Wire Cutting Machines

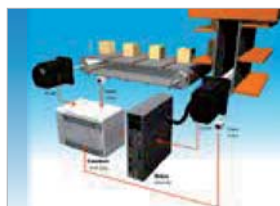

Feeding Machines



High-speed Labeling Machines

AC Servo Drive EtherCAT[®]

ASDA A2-E

Supports EtherCAT High-speed Communication

Delta's ASDA A2-E, an advanced AC Servo Drive with an EtherCAT communication interface, complies with IEC61158 and IEC61800-7 to enable faster, real time, and accurate performance in high-end applications.

The new A2-E the supports a CoE device profile based on CiA402, and all command types of EtherCAT.

In addition to the EtherCAT communication function, the A2-E features the integrated Safe Torque Off (STO), short cycle time, and extension digital input port, which makes the A2-E ideal for multi-axis synchronization applications in a wide range of machinery automation applications. This series offers a wide range of rated power to drive motors, from 400W to 7.5kW for 400V and 100W to 3kW for 220V.

- Touch probe function can be enabled with two dedicated Digital Inputs (DI) on CN7 or the external encoder
- Integrated Safe Torque Off (STO) safety function complies with the standards of IEC61508, SIL2; IEC62061, SILCL2; ISO13849-1, Cat. 3 PL=d
- Wide power range coverage for both 220V and 400V versions
- Supports full-closed loop control
- Supports absolute type and incremental type ECMA Series motors



EtherCAT controllers

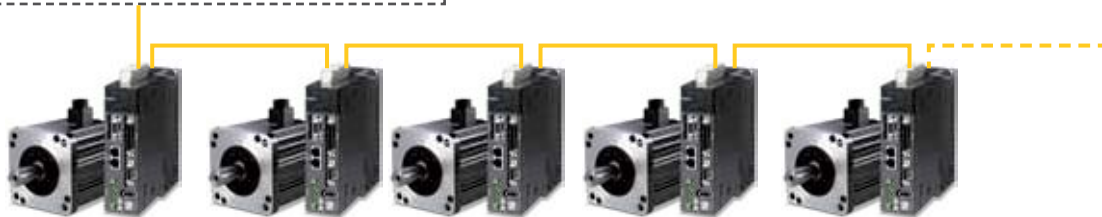
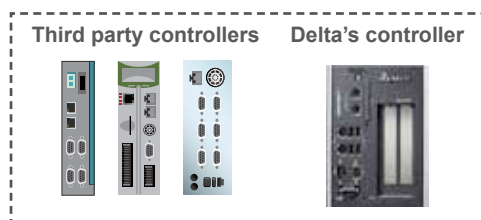

Applications



Metal Working Machines



Woodworking Machines



Food Processing



Printing Machines

Communication Specifications

Physical Layer	IEEE802.3u (100 BASE-TX)
EtherCAT Commands (Data Link Layer)	APRD, FPRD, BRD, LRD, APWR, FPWR, BWR, LWR, ARMW, FRMW, APRW, FPRW, BRW, LRW
Device Profile (CiA402)	Homing Mode, Profile Position Mode, Profile Velocity Mode, Profile Torque Mode, Interpolated Position Mode, Cyclic Syn. Position Mode, Cyclic Syn. Velocity Mode, Cyclic Syn. Torque Mode, Touch Probe Function, Torque Limit Function
Process Data Size	Tx: 8 Object (32 byte, Max.) Rx: 8 Object (32 byte, Max.) Dynamic Mapping Support.
Bus Clock	DC cycle with min. 250 μ s
LED Indicator	EtherCAT Link/Activity Indicator (L/A)x2 EtherCAT RUN Indicator (RUN)x1 EtherCAT ERROR Indicator (ERR)x1

Part Names and Functions

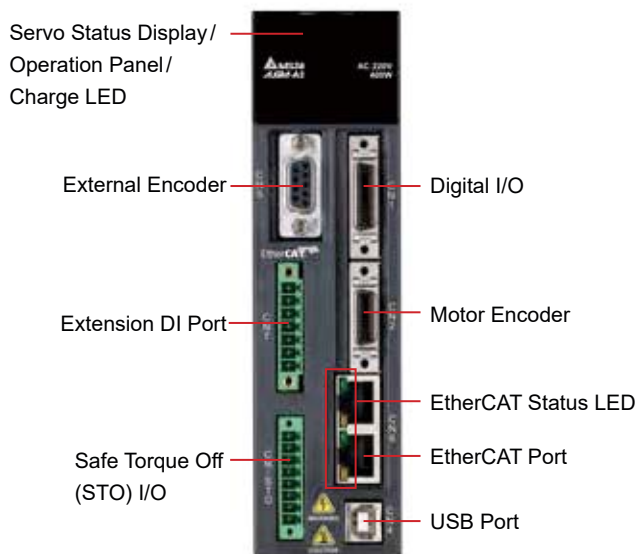

Accessories for ASDA A2-E

Part Number	ASD-CN5C0026
Description	CN1 connector
Part Number	ASD-CNFS0808
Description	Pack of connectors used for STO wiring, 8 pcs of connectors in one pack



AC Servo Drive & Motor

ASDA-B2

Implements 17-bit (160,000 p/rev) high resolution encoder as a standard



Power Range: 0.1 kW ~ 3 kW

- Input Voltage: 200 V_{AC} ~ 230 V_{AC}, 1-phase/3-phase, or 3-phase
- Meets high precision positioning control requirements of general-purpose machine tools
 - Built-in Position, Speed and Torque modes (Speed and Torque modes can be controlled via internal parameters or external voltage)
 - Provides pulse input (up to 4 Mpps) and analog voltage commands
 - Three notch filters are provided to optimize the operation of the mechanical system automatically
 - Friction compensation and motor protection functions are available to reinforce the system
 - Power of main circuit and control circuit is separated
 - Maintenance is easy and very safe
 - Built-in regenerative resistor is featured as standard (400W and above models). No need to purchase or wire up a separate regenerative resistor



Applications



Bar Feeders



Transporting and
Conveying Equipment



Electric Discharge
Machines (EDM)



Cutting Machines

High Accuracy for Positioning

- ASDA-B2 Series features an incremental encoder with 17-bit resolution (160,000 p/rev) which can eliminate unstable commands at low speed, smooth the motor operation and enhance the accuracy of positioning

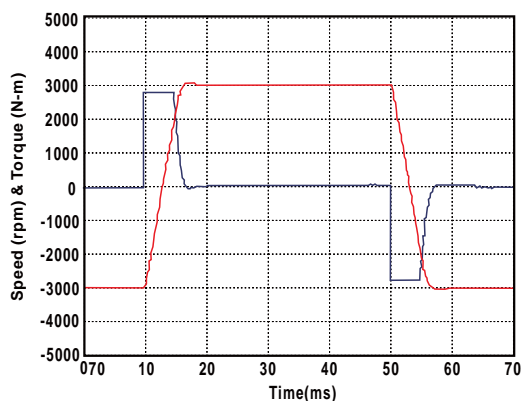
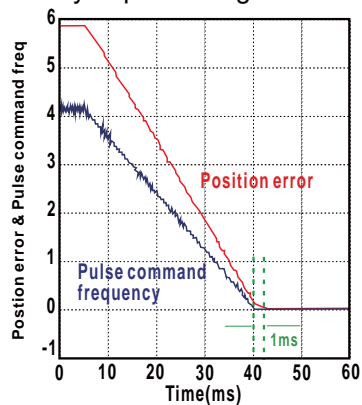

- Three auto notch filters are provided to suppress mechanical resonance efficiently

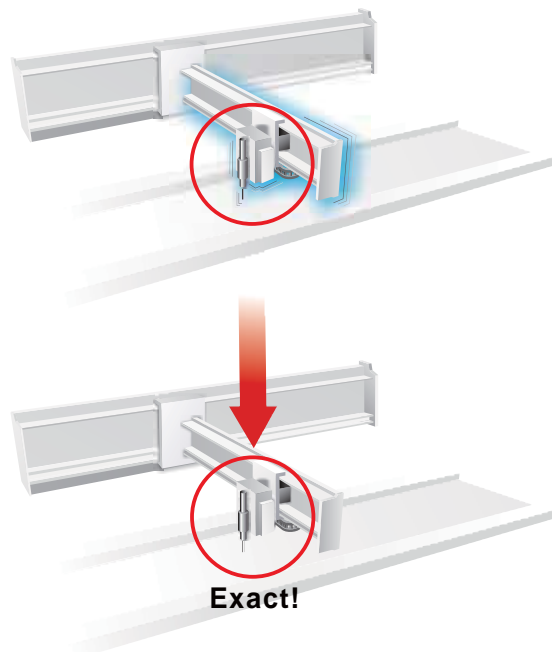

Easy-to-Use and Cost-Saving

- The same power and encoder cables as the ASDA-B Series. Easy to set up and no extra accessories are required
- Easy-to-use digital keypad is ideal for setting parameters and monitoring the system directly



- Built-in regenerative resistor (400W and above models) is provided. Simplifies wiring and minimizes space

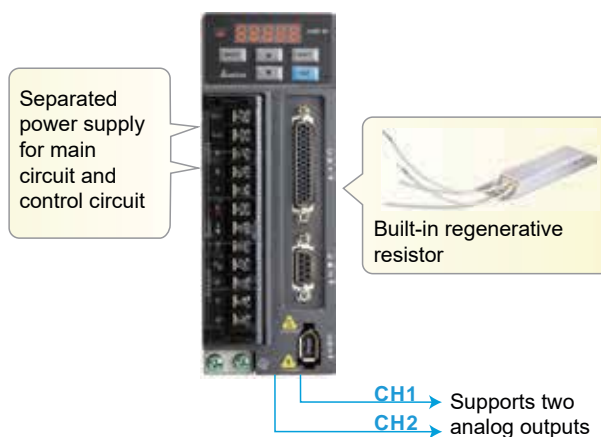

AC Servo Drive & Motor

ASDA-M

Three-in-one Intelligent Servo System Harmonizing Motion Controller and Servo Drive

Impeccable motion control inside

- 3-axis synchronous servo module with performance better than comparable three servo drives
- Built-in motion control and PLC functions
- Multi-axis synchronous interpolation and built-in motion control commands are ideal for applications requiring high synchronous control accuracy
- Versatile PR mode for various continuous motion movements
- Built-in G-code interpreter

New PC Software Functions

- ASDA-Soft provides built-in contour analysis function
- EzASD provides PLC programming and motion commands editing environment

High Precision, High Performance Servo Motors

- Supports incremental type and absolute type encoders
- Incremental type encoder provides up to 1,280,000 p/rev resolution for high-precision positioning



Product Line-up

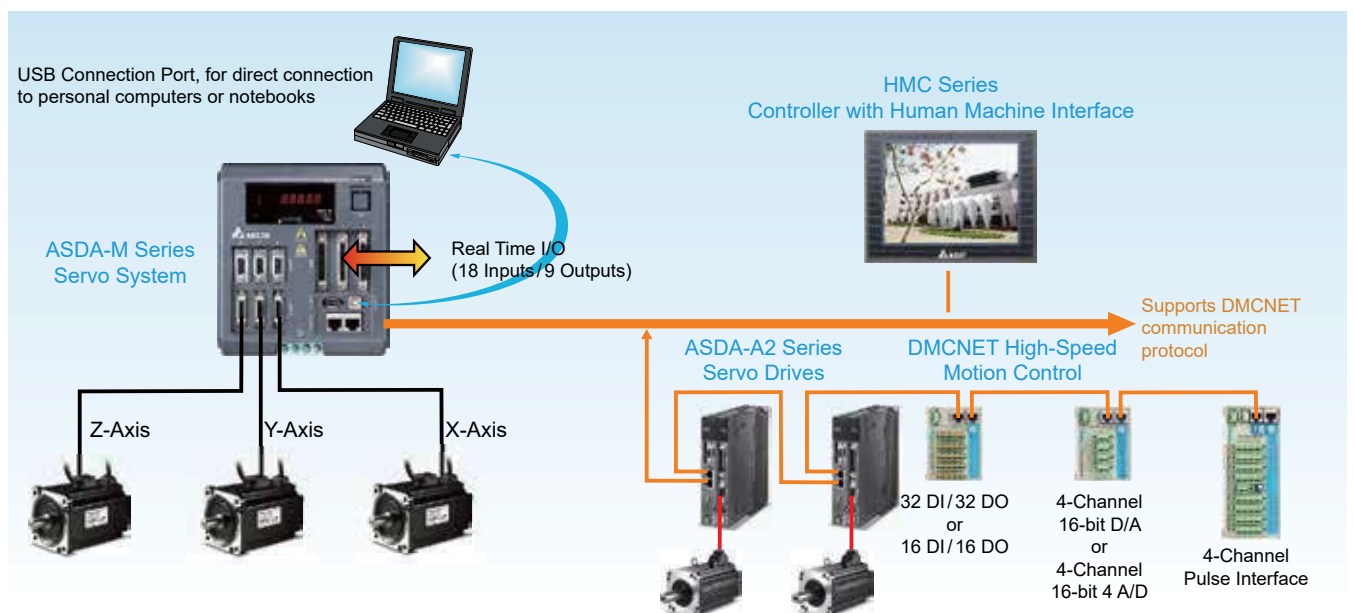

Real Time, Reliable and High-Speed Motion Control Network

- Supports DMCNET and CANopen communication protocols
- With the aid of Delta's Controller with Human Machine Interface (HMC), it can establish an integrated system configuration by DMCNET
- Supports DMCNET extension digital input and output modules

Advanced Gantry Control

- A large amount of data can be exchanged in real time among 3 axes without any time delay. This greatly increases the efficiency and performance of gantry control
- In rigid or general mechanical systems, no matter if the loading on multiple axes is equal or not, the ASDA-M Series can perform precise motion control and drive for each axis simultaneously

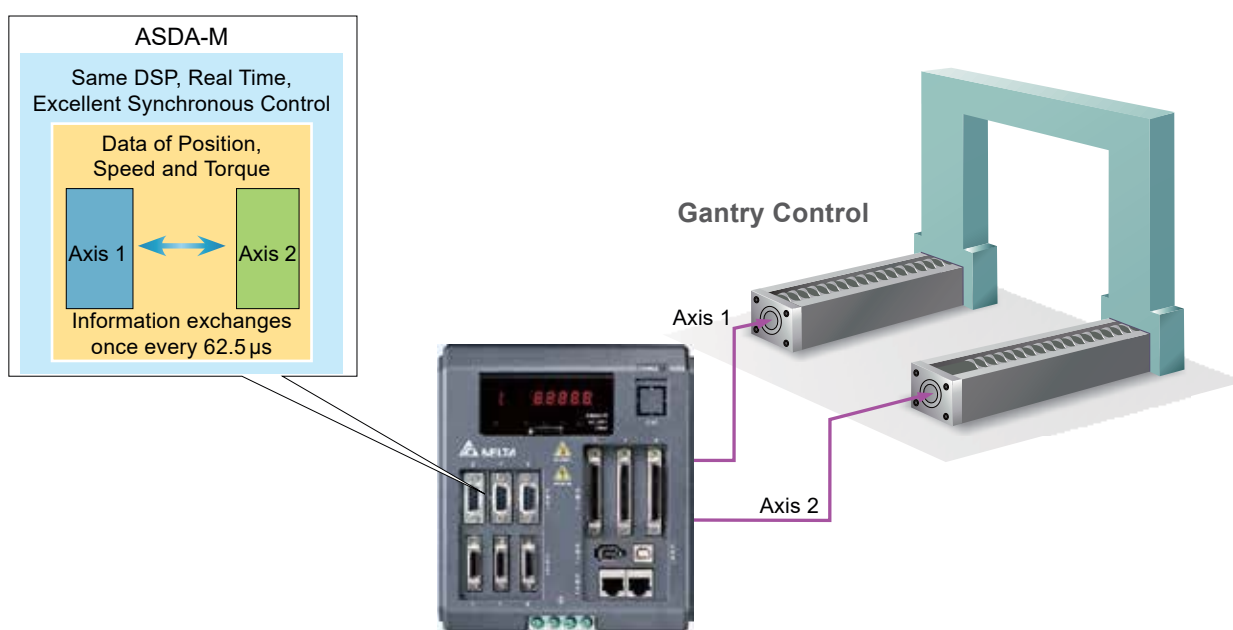

Gantry Control

Axis 1

Axis 2

Built-in G-code Interpreter

- G-code commands are downloaded and executed to the servo drive through HMI or PC
- ASDA-M Series provides built-in G-code interpreter to decode the G-code commands and complete the motion movement

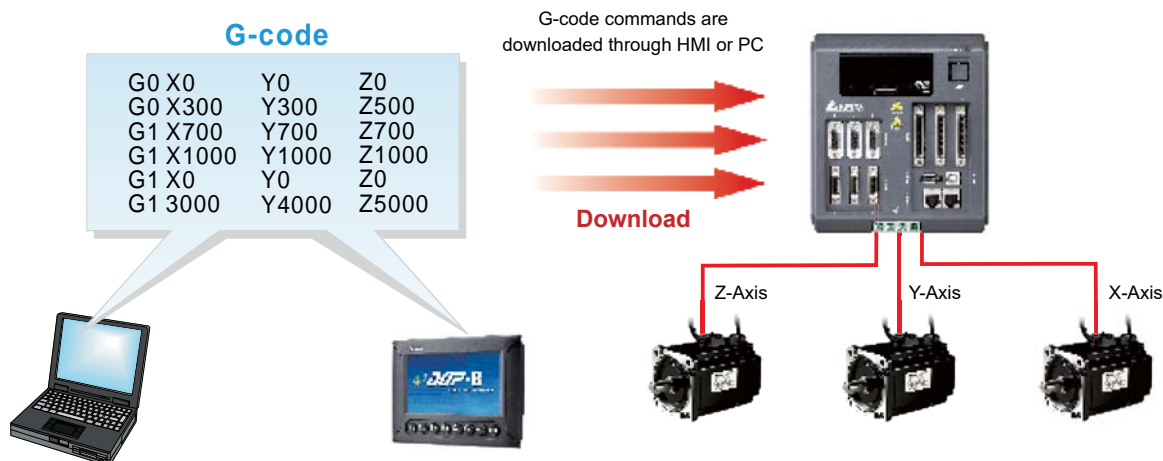

Spindle Motor Drive

ASDA-S

Ensuring Premium Surface Finish Quality for the CNC Industry

Power range: 3 kW~15 kW

- Supports Delta permanent magnet spindle motors and other induction motors
- Provides high performance servo vector control as in the ASDA-A2 Series
- Supports pulse encoder signals (ABZ phase) via CN5 port. External converter card is no longer necessary
- Built-in induction motor parameter measuring and estimating function
- Offers V/F control for induction motors without encoders
- Equipped with analog speed and resolution switching function
- Accepts analog voltage, position pulse and DMCNET communication commands
- 200V models and 400V models are available for selection
- Capable of connecting to CNC controllers via DMCNET high-speed serial communication

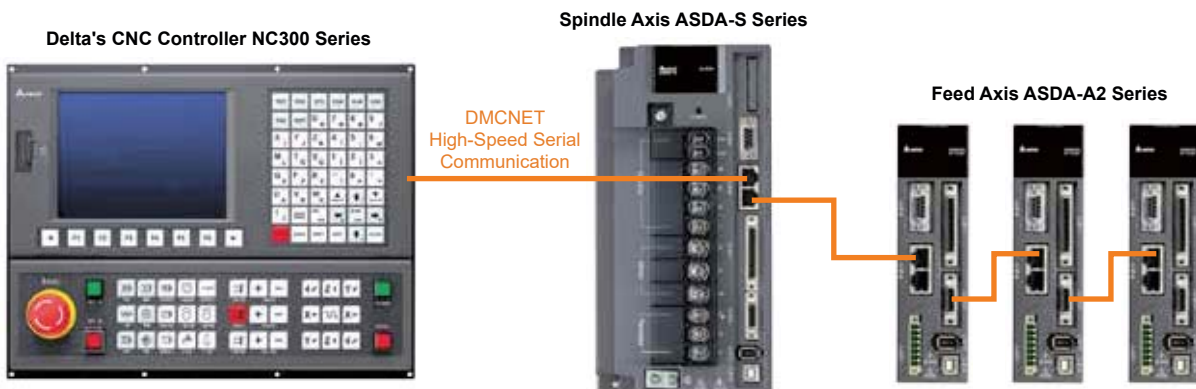

IPM Spindle Motor

ECMS

Power range: 3.7 kW/6.7 kW

- Encoder Type: Incremental 20-bit
- Max. torque: 14.72 N-m/26.65 N-m
- Speed range: 6000 r/min ~ 12000 r/min
- Options: Coolant through spindle
- IP degree: IP54



Linear Motion Drive

ASDA-A2R

Delivering a Superior Linear Motor

The new ASDA-A2R Series linear drive system provides high accuracy, high rigidity and high response. It not only expands the applications of the servo system, but also increases the work efficiency of the motion control system and satisfies high-precision requirements.

The ASDA-A2R follows in the footsteps of Delta's successful servo system and provides the same functions such as high-speed and high response performance, excellent vibration and resonance suppression, versatile PR mode, DMCNET and CANopen communication interfaces, built-in E-Cam and gantry control functions.



Power range: 100W~3kW

- Intelligent motor parameter measuring, easy and fast auto tuning
- Accurate positioning and initiation without a Hall sensor unit
- High flexibility in connecting various kinds of linear motors and servo motors
- Signal Converter Box (Delta option) available for high speed and high precision requirements
- - Supports AB phase square waves of digital signals
- - and sine waves of analog signals
- - Signals can be divided up into a multiple of 2048 to
- - increases positioning resolution for precise position control
- Detection and compensation of cogging force

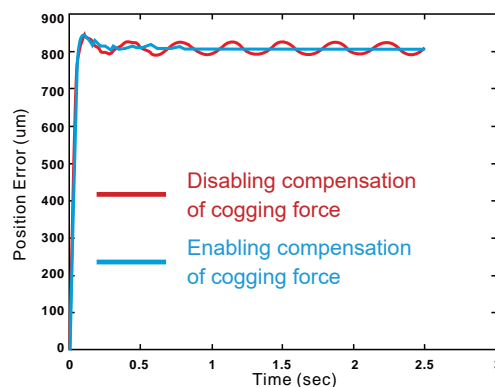

Ironless Linear Motor

ECML

Power range: 100 W~750 W

- Rated thrust: 21~177 N
- Direct driving mechanism, high speed and high precision control
- No cogging forces and low thrust ripple



Linear Shaft Motor

ECML-S

High-speed, High-precision Linear Motor Position Repeatability within $\pm 1 \mu\text{m}$

- Simple mechanism structure for quick installation
- Direct driving mechanism, easy to replace ballscrew mechanism
- No cogging forces, low thrust ripple
- Excellent dynamic response
- No backlash
- Built-in temperature sensor and hall sensor units
- Large air gap for easy installation
- Installation holes on both sides in the coil assembly for easy mounting



Thrust Range

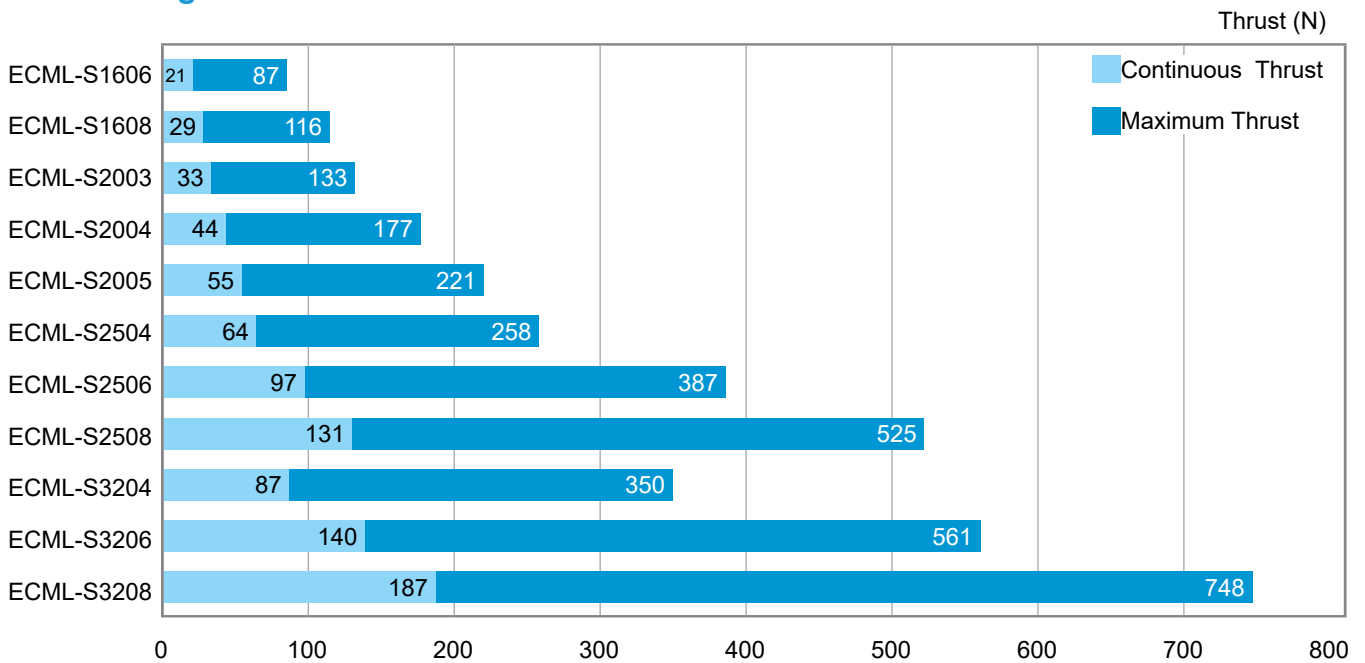

Length of Magnetic Way (Dimensions are in mm)

Shaft Diameter	Minimum Length	Maximum Length	Increments
ECML - SM16	250	1240	30
ECML - SM20	250	1270	60
ECML - SM25	330	1650	60
ECML - SM32	450	2310	60

Linear Stage

LU

High Precision Steel Ballscrew Driven Stage Position Repeatability of $\pm 3 \mu\text{m}$

- Non-coupling mechanism design
- Compact size for space saving
- High rigidity and high accuracy
- Fast response
- Low inertia ratio



Characteristic Analysis



Delta LU Series
(without coupling)



Conventional Linear Stage
(with coupling)

Measured Data by Laser Interferometer

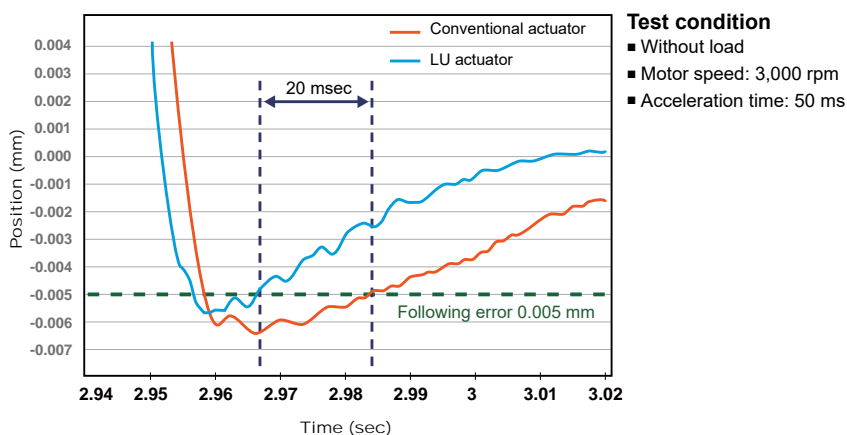

Thrust Range

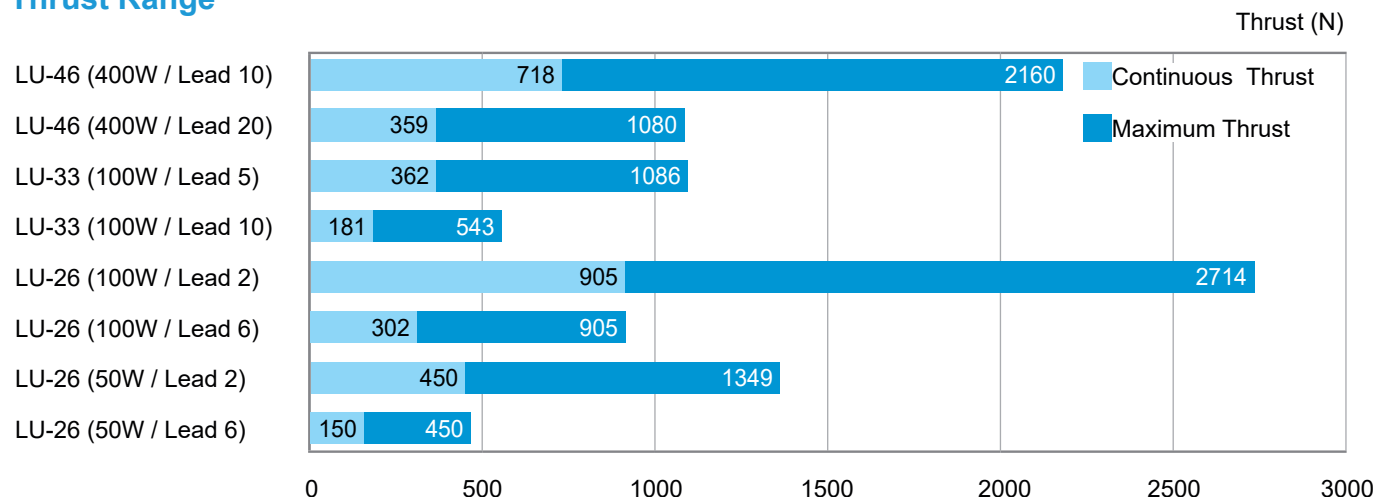

Linear Stage

LA-S

High Speed, High Precision Linear Motor Driven Stage Position Repeatability of $\pm 1 \mu\text{m}$

- **Direct driving with zero backlash**

Directly driven by Delta's linear motor, without backlash and alignment issues

- **High speed and high precision**

- Provides high-precision and high-stability motion operation: high speed capability of up to 4m/s
- Integrates with linear motor and optical linear encoder for direct driving and preventing backlash and accumulated offsets caused by changing machines

- **Cog-free design with low thrust ripple**

Uses an ironless forcer for zero cogging and low thrust ripple to perform smooth motion, even at low speed

- **Long travel distance with multiple sliders**

- Good performance on long travel distances (up to 1.5m) for various positioning applications
- Single-axis platform supports more than 2 linear motors, creating multiple sliders within one stage unit for efficient space savings and independent operation



Mechanism Design

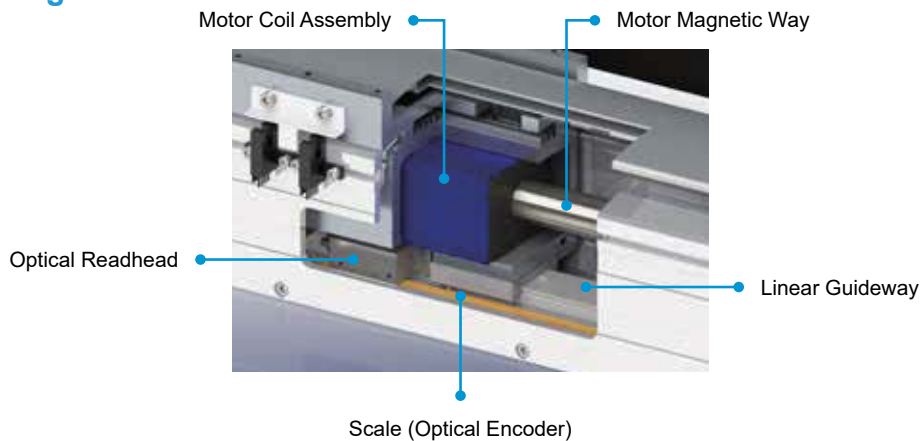

Thrust Range

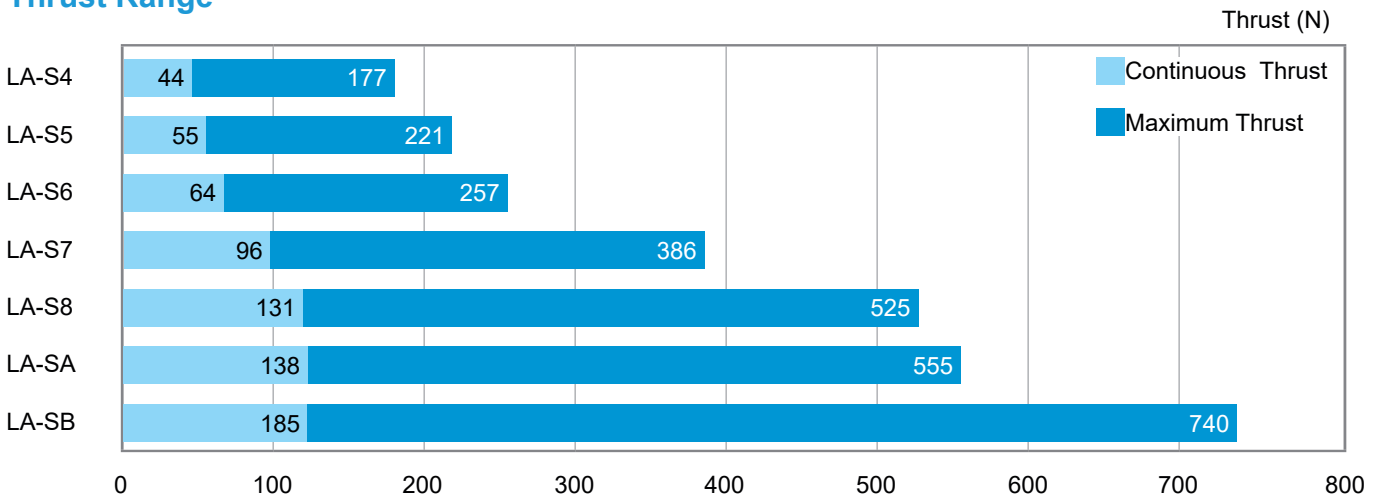

High Precision Planetary Gearbox

PS



- **Supports all series of Delta servo motors**
- **Provides concentric and right-angle models**
- **High precision**
 - Backlash for concentric 1-stage gearbox is under 3 arcmin
 - Backlash for right angle 1-stage gearbox is under 4 arcmin
- **High input speed**
Input speed allows for 5,000 RPM
- **High torque**
Helical gear design offers higher output torque in comparison with spur gearbox
- **High efficiency**
 - Efficiency for 1-stage model exceeds 97%
 - Efficiency for 2-stage model exceeds 94%
- **Low noise**
Under 65dB
- **Lifetime lubrication**
Protective class IP65 sealed design avoids leakage problems and requires no maintenance during the product's lifetime

Precision Planetary Gearbox

PA



- **Supports all series of Delta servo motors**
- **Provides concentric models**
- **High rigidity and high torque**
 - Employs uncaged needle roller bearings with a set design
 - including ring teeth, gearbox and helical gears for high rigidity and output torque
- **High precision**
 - Backlash for 1-stage gearbox is under 8 arcmin
 - Backlash for 2-stage gearbox is under 12 arcmin
- **High efficiency**
 - Efficiency for 1-stage model exceeds 95%
 - Efficiency for 2-stage model exceeds 92%
- **Low noise**
 - Uses helical gears capable of meshing to ensure smooth
 - and quiet operation
- **Lifetime lubrication**
 - Protective class IP65 sealed design avoids leakage problems and requires no maintenance during the product's lifetime

PC-Based Motion Controller (PAC)

MH1 / MP1

A Perfect Balance of EtherCAT Fieldbus and High-Performance Motion Control

- **Energy Efficient and Robust Hardware**

- The MH1 Series: provides a cable-less, fan-less and low-power consumption design, increasing reliability and providing CFast card and SSD slots inside for fast and stable data transmission
- The MP1 Series: equipped with a 10.1-inch touchscreen for more flexible operation

- **Multiple Peripheral Interfaces for Communication**

Equipped with USB ports, serial COM ports, Gbps Ethernet ports and PCI/PCIe extension slots

- **Supports EtherCAT and DMCNET Master and Slave Modules**

Up to 12 units of DMCNET modules and 12 servo axes of motion control, and up to 100 units of EtherCAT modules and 64 axes of motion control are able to be connected and controlled. For implementing multiple I/O extensions and achieving more axes of motion control: the PCI-DMC-B01 and PCI-L221-B1

- **High Security**

Customizable IC device for programming security and confidential protection

- **Software Support**

The MH1 Series: equipped with Real Time OS (Windows CE, RTX)*, Windows 7/10 Embedded and a library of other software

* When changing to this environment, please contact customer service



Host PAC
MH1

Panel PAC
MP1

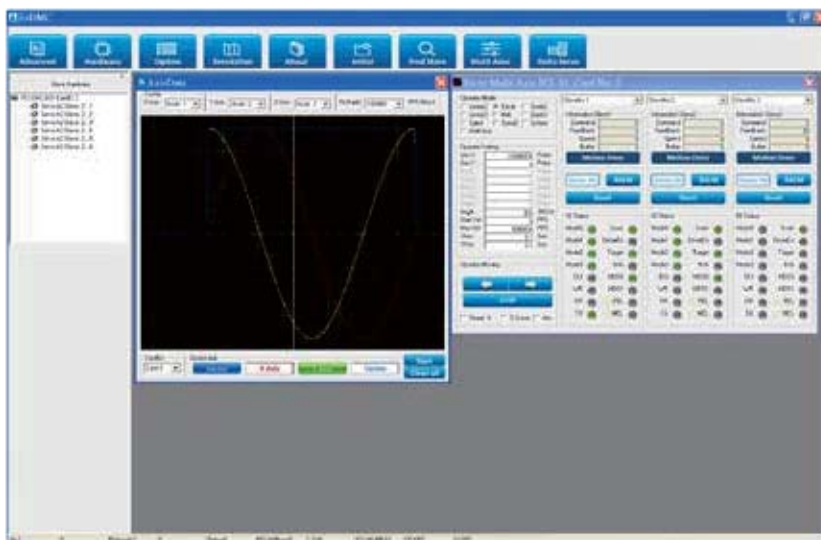

Motion Control

- Point-to-point position control
- Linear interpolation (multi-axis)
- Two-speed motion (single-axis)
- Circular interpolation
- Helical interpolation
- Backlash compensation
- Compensation for helix deviation
- Compare
- Table motion
- JOG
- PT/PVT
- Gantry control (EtherCAT Communication)
- E-CAM (EtherCAT Communication Structure)

- **Speed Curve Tracing**

Integrates speed curves tracing function for tracing current motion commands to achieve better synchronization effects between multiple axes efficiently

- **Simulation Scope**

Verifies and controls timer, sequential and motion tracks for fast response and high-end motion via 2-dimension scope function

- **DMCNET/EtherCAT Automation Software**

EzDMC/ EcNavi development software: includes a DMCNET / EtherCAT master controller and slave devices for data communication, functional identification, programming and debugging, providing a fast and easy way for first-timers to understand the solution

Applications

Electronics Production: PCB machines, Automated Optical Inspection (AOI) machines, semi-conductor machines, LED machines, TFT inspection machines, glue-dispensing machines, SMT pick-and-place machines, winding machines, optical lens processing machines, glass grinding machines

Woodworking: CNC drilling machines, woodwork cutting machines, board slitting machines

Other: Bending machines

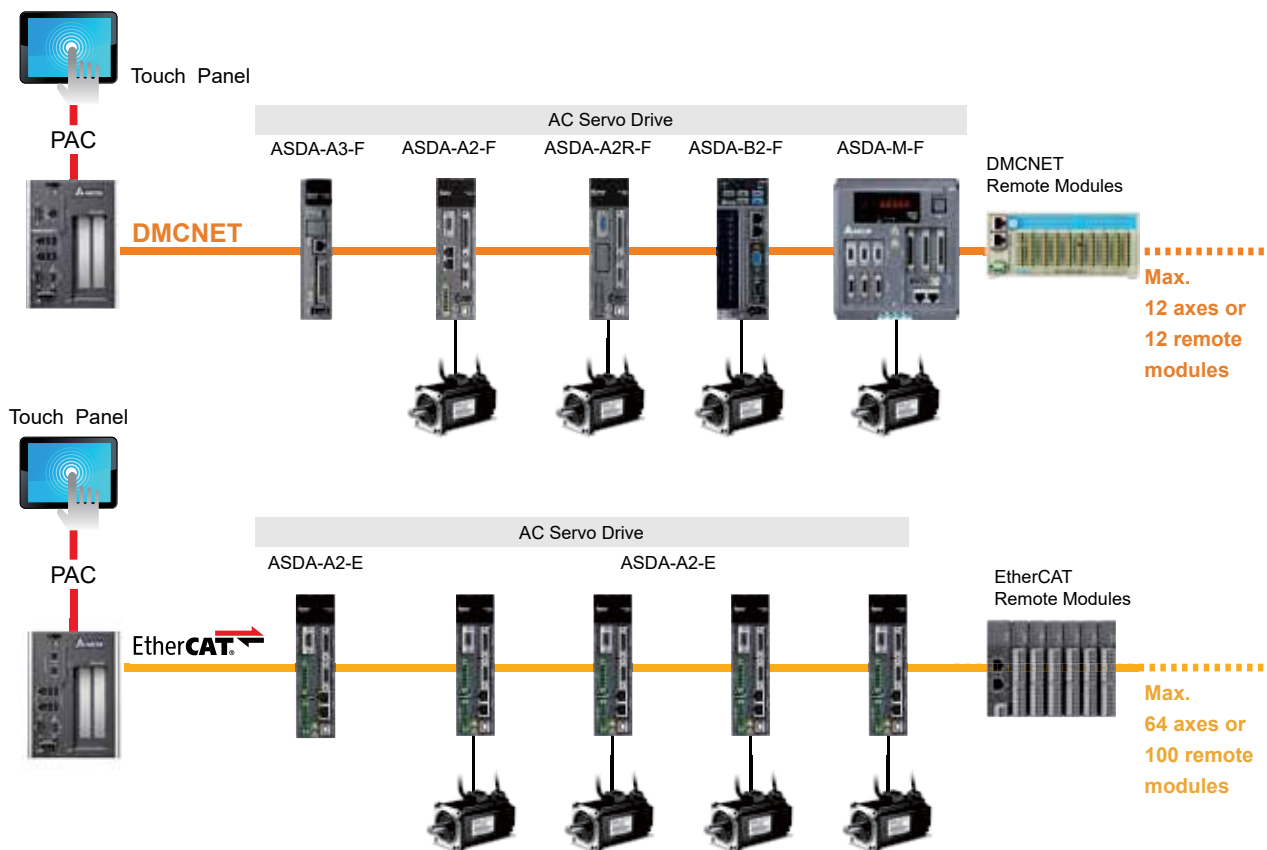

Centralized Slave Module

- Gateway Type E-BUS Remote Power Coupler**

R1-EC5500D0 / R1-EC5512D0

Connect to digital I/O, analog I/O and pulse I/O extension modules



- 1-Channel Pulse Remote Module**

R1-EC5621D0

Use E-BUS power module and EtherCAT remote modules for single-axis pulse motion control



- 16 Digital Input Remote Module**

R1-EC6002D0 / R1-EC6022D0

Use E-Bus power module and EtherCAT remote modules for digital control



- 16 Digital Output Remote Module**

R1-EC7062D0 / R1-EC70A2D0 / R1-EC70E2D0 / R1-EC70F2D0

Use E-Bus power module and EtherCAT remote modules for digital I/O control



- 4-Channel Analog Input Remote Module**

R1-EC8124D0

Use E-Bus power module and EtherCAT remote modules for analog I/O control



- 4-Channel Analog Output Remote Module**

R1-EC9144D0

Use E-Bus power module and EtherCAT remote modules for analog I/O control



Delta High-Speed Motion Control System

DMCNET

Delta's Motion Control NETWORK (DMCNET) is a high speed, real-time communication system, capable of controlling up to 12 axes of servo system units within 1ms simultaneously: with 3-axis helical and linear interpolation in 4 groups, or 2-axis linear and arc interpolation in 6 groups. It supports 64-bit dual-precision floating point, allowing high-precision system calculations and flexible operation, and also absolute commands, incremental commands and T-curve / S-curve velocity profiles for different uses. With built-in position, speed and torque control modes, and 35 homing modes, it is able to receive real-time servo information, parameters, or change control modes via communication command, offering fast communication and motion control for various applications



DMCNET is equipped with the high-speed and reliable one-wire DMCNET communication protocol for diverse motion control applications. Adapted for customer's needs, Delta's PCI motion control cards are available in three series: the 12-axis PCI-DMC-A02, 6-axis PCI-DMC-F02 with digital I/O interfaces and the PCI-DMC-B01 with pulse compare & capture functions. All series are able to connect to multiple servo systems, such as the high-performance ASDA-A2-F Series, standard ASDA-B2-F Series, or ASDA-A2R Series. Combining with Delta's linear motors, the series establishes a total motion control solution enabling lower system cost and superior performance to increase end-product value and competitiveness

DMCNET System Configuration

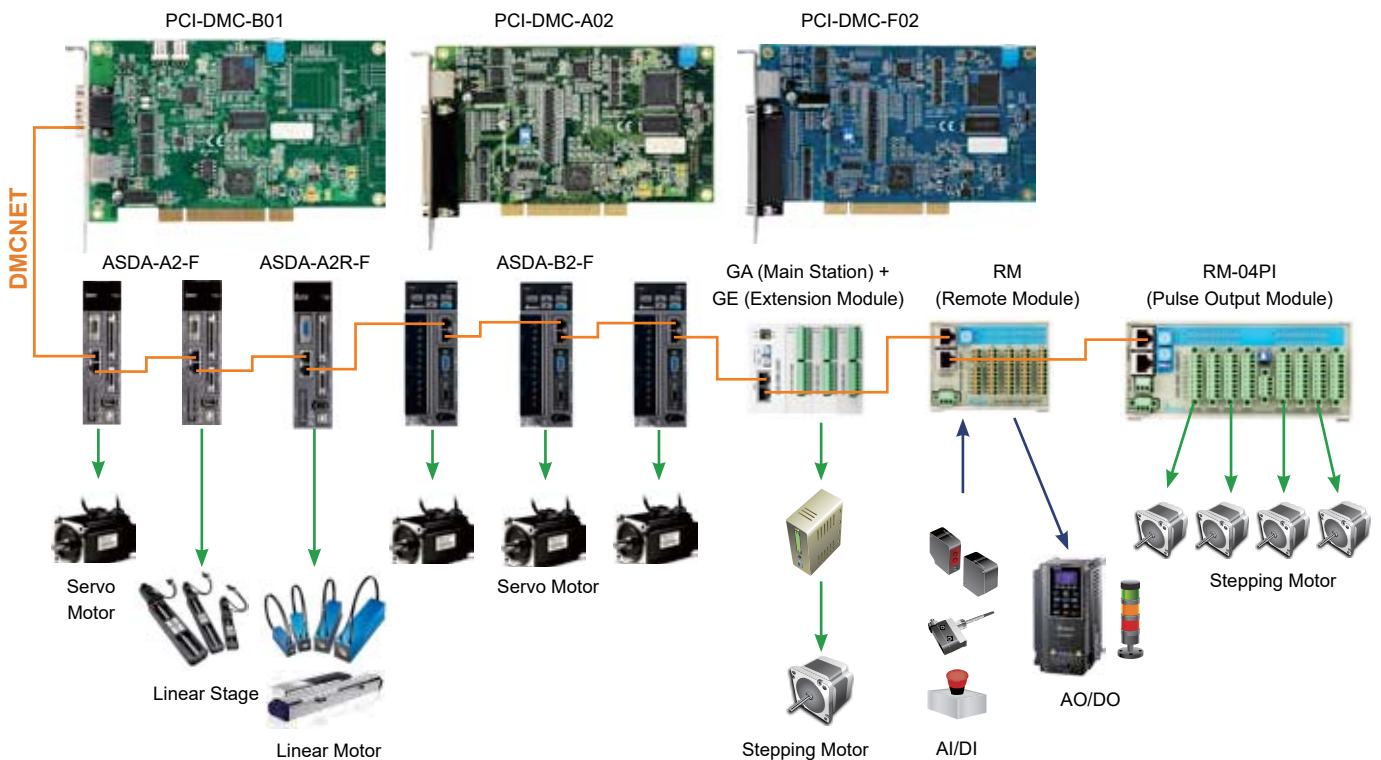

Applications

Electronic integrated applications, glue dispensing machines, woodworking machines, tube bending machines

IPC Motion Platform (IMP1.5)

A Simple and Fast Setup Development Platform for Realizing Unsurpassed Motion Control

The IMP is a high-speed, flexible and scalable development platform which combines powerful motion control functions and integrates Delta's HMI editing and PLC logic programming software tools to achieve complex and precise motion control based on customers' requirements

- **Power Motion Control Core:** Upgrades Delta's PAC and PC with a motion control card installed to become an advanced
- **Simple Secondary Development Platform:** Combines with Delta's standard HMI editor DOPSoft and PLC editor WPLSoft in one customer-driven platform to make complex programming and development easy and time-saving without depending on technical support from the manufacturer
- **Scalable Communication for Expandable Network:** Through PCI extension slots, three DMCNET communication networks with up to 36 stations can be established, which means 36 axes of servo motors can be controlled simultaneously without connecting to any remote modules
- **Industry-Oriented Controller:** Provides Soft Numeric Control (SNC) and Motion Program Macro (MPM) to adjust and modify self-defined motion paths and commands according to changing application requirements
- **Standard Communication Interfaces:** Supports built-in standard MODBUS and MODBUS TCP gateways to enable more convenient data transmission exchange between machines

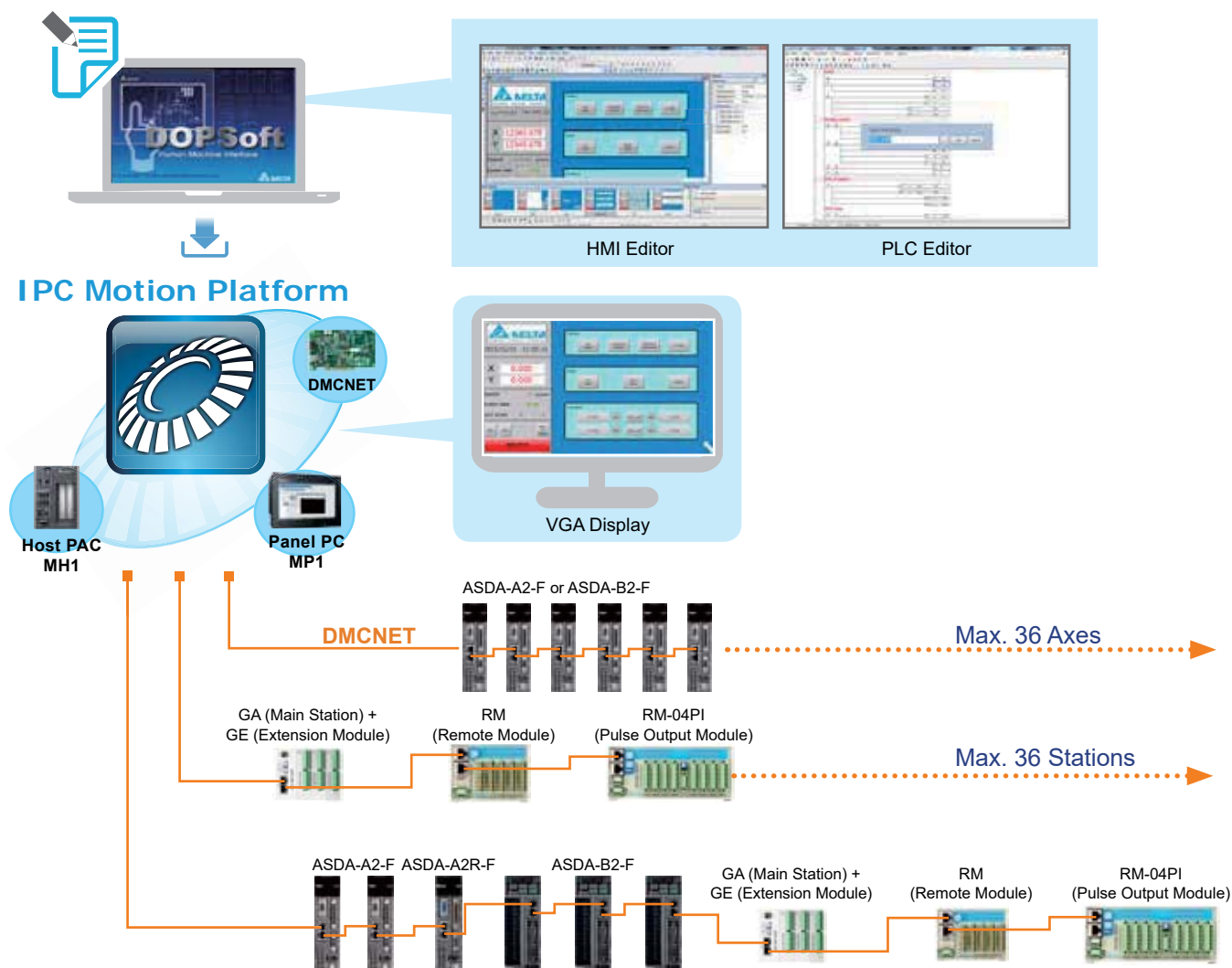

High-Speed Motion Control System ^{New}

EtherCAT

EtherCAT Motion Control Products (Ethernet Control Automation Technology) is an open Ethernet-based fieldbus system that provides high-efficiency and high-performance synchronization quality for automation control.

With EtherCAT, Delta's EtherCAT motion control card PCI-L221-P1 achieves rapid and real-time multiple axes of motion control, and is capable of controlling up to 100 slave stations that enable a 64-axis motion control within 1ms cycle time. It also provides 35 homing modes, point-to-point position control, 2-axis interpolation, 3-axis interpolation, multi-axis synchronization, continuous motion, gantry control, speed control, torque control and more



Delta provides a high-speed motion control card PCI-L221-XXD0 with complete functions for EtherCAT masters. Supporting device descriptions in XML format (EtherCAT Slave Information - ESI), the PCI-L221-XXD0 also allows the system to quickly identify ESI files and offers the capability of real-time connection via EtherCAT for high level integration. It can adjust the communication cycle time between stations within 1ms to 0.5ms according to customer needs

EtherCAT System Configuration

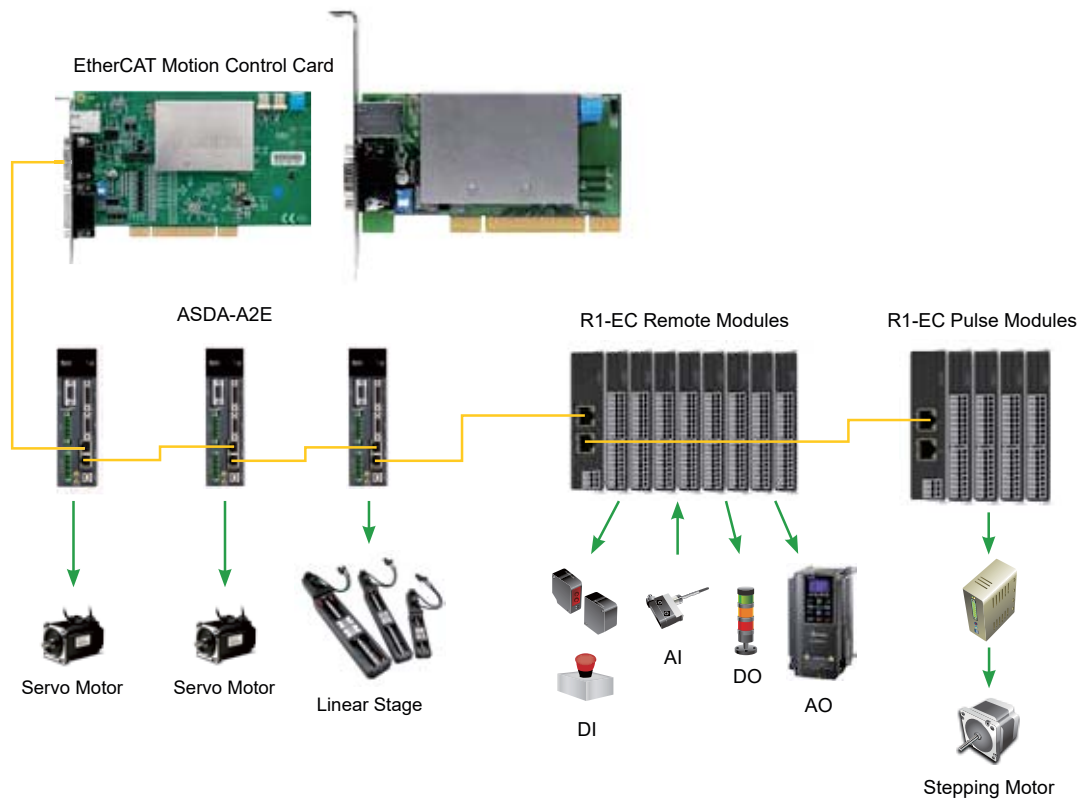

Applications

Electronic integrated applications, glue dispensing machines, woodworking machines, tube bending machines

IPC Motion Platform (IMP1.5)

A Simple and Fast Setup Development Platform for Realizing Unsurpassed Motion Control

The IMP is a high-speed, flexible and scalable development platform which combines powerful motion control functions and integrates Delta's HMI editing and PLC logic programming software tools to achieve complex and precise motion control based on customers' requirements

- **Power Motion Control Core:** Upgrades Delta's PAC and PC with a motion control card installed to become an advanced motion controller that integrates the functions of motion control, HMI, PLC and high-speed communication fieldbus in one unit
- **Simple Secondary Development Platform:** Combines with Delta's standard HMI editor DOPSoft and PLC editor WPLSoft in one customer-driven platform to make complex programming and development easy and time-saving without depending on technical support from the manufacturer
- **Scalable Communication for Expandable Network:** Through PCI extension slots, three DMCNET communication networks with up to 36 stations can be established, which means 36 axes of servo motors can be controlled simultaneously without connecting to any remote modules
- **Industry-Oriented Controller:** Provides Soft Numeric Control (SNC) and Motion Program Macro (MPM) to adjust and modify self-defined motion paths and commands according to changing application requirements
- **Standard Communication Interfaces:** Supports built-in standard MODBUS and MODBUS TCP gateways to enable more convenient data transmission exchange between machines

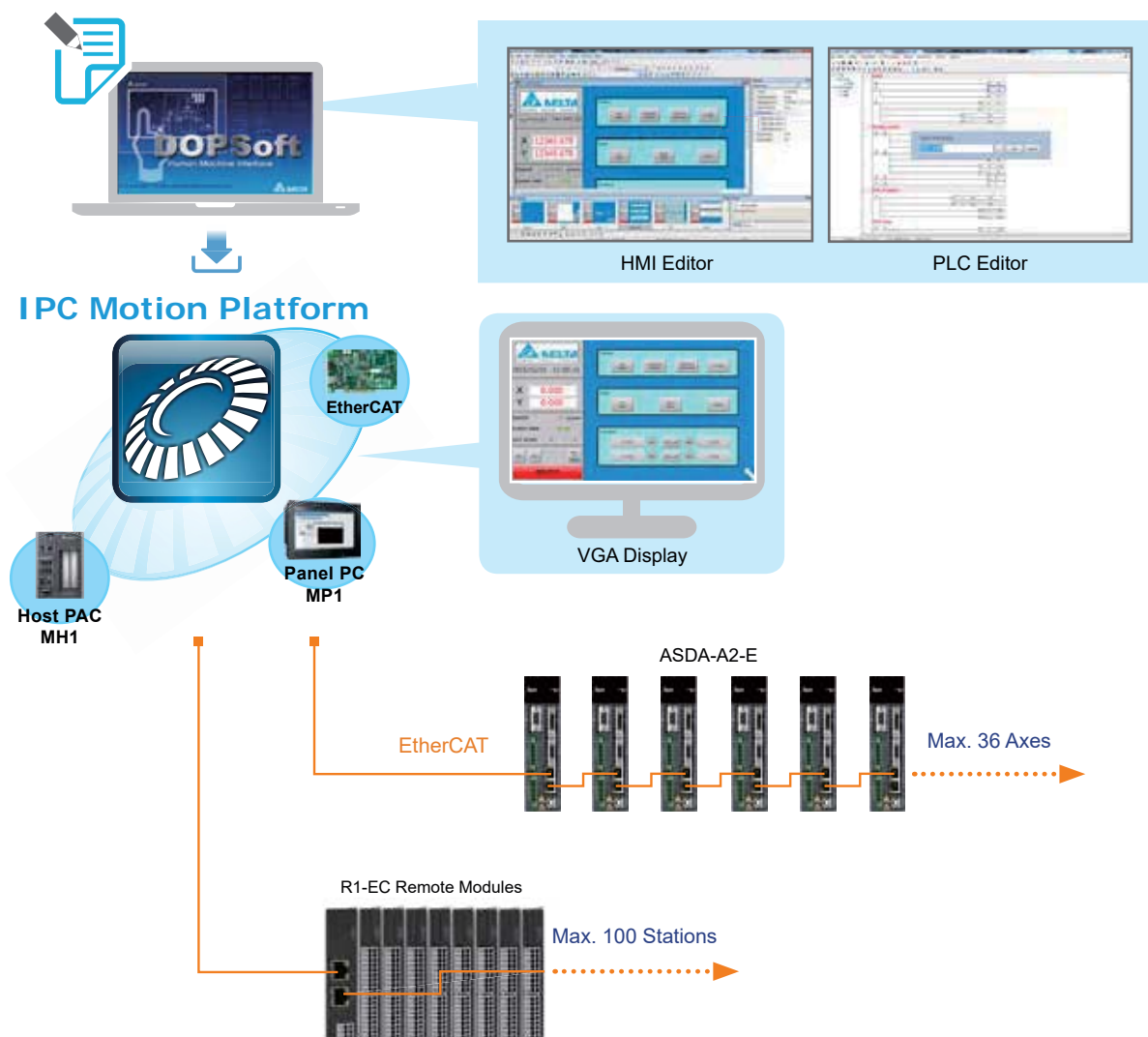

Open CNC Solution New

NC E

Open-structured CNC Control System for Customization and Flexibility



Solution 1: Standard

VGA output for external display with Delta's standard interface

- Two-language CNC operation interface (Chinese, English)
- Embedded control system provides high efficiency
- Allows easy customization with accessories including a monitor and a keyboard
- Supports DMCNET communication for easy wiring and excellent synchronous multi-axis control

Solution 2: Function-Oriented

Matches with panels or other products based on applications

- API platform and template are provided for users to self-define the HMI functions
- Easy integration with third party software via IPC
- Reduces additional hardware cost for customers to focus more on software upgrades and better integrated operation performance

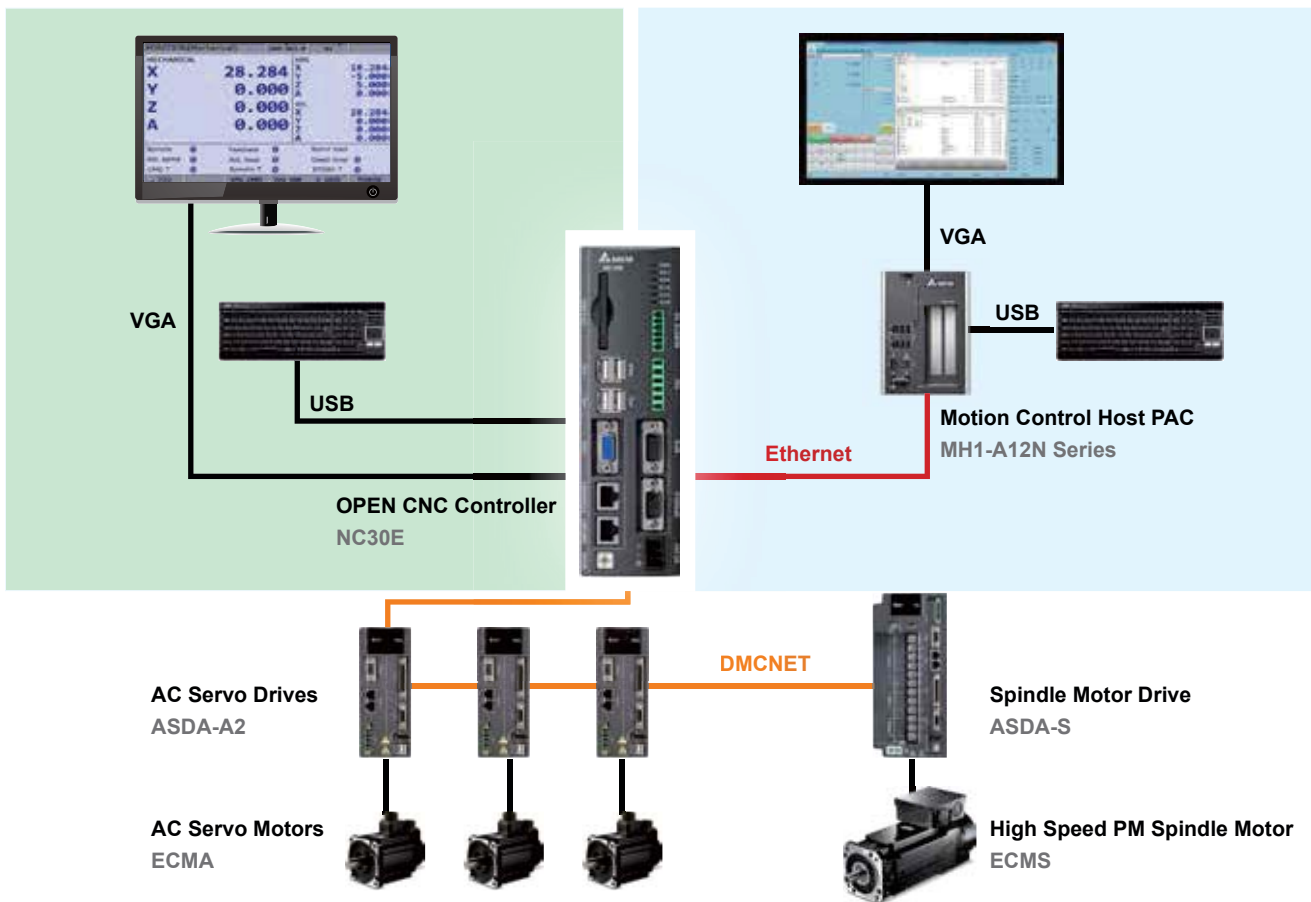

Applications

Customized CNC system, woodworking machine, lathe, grinding, glass cutting, spot welding, rim engraving, robot arms, milling

CNC Solution

Integrated Total Solution for the CNC Machine Tools Industry



- Built-in 32-bit high speed and high processing dual CPU to construct a real-time and multi-functional control center
- High-quality digital data transmission when matched with Delta's high-speed servo and spindle systems
- Auto-gain tuning allows automatic servo system parameter settings to achieve easy and real-time optimum control
- CNCSoft software offers user-friendly setup and user-defined operation to build customized screens
- Capable of connecting serial digital I/O modules to greatly improve the extension capacity

System Configuration

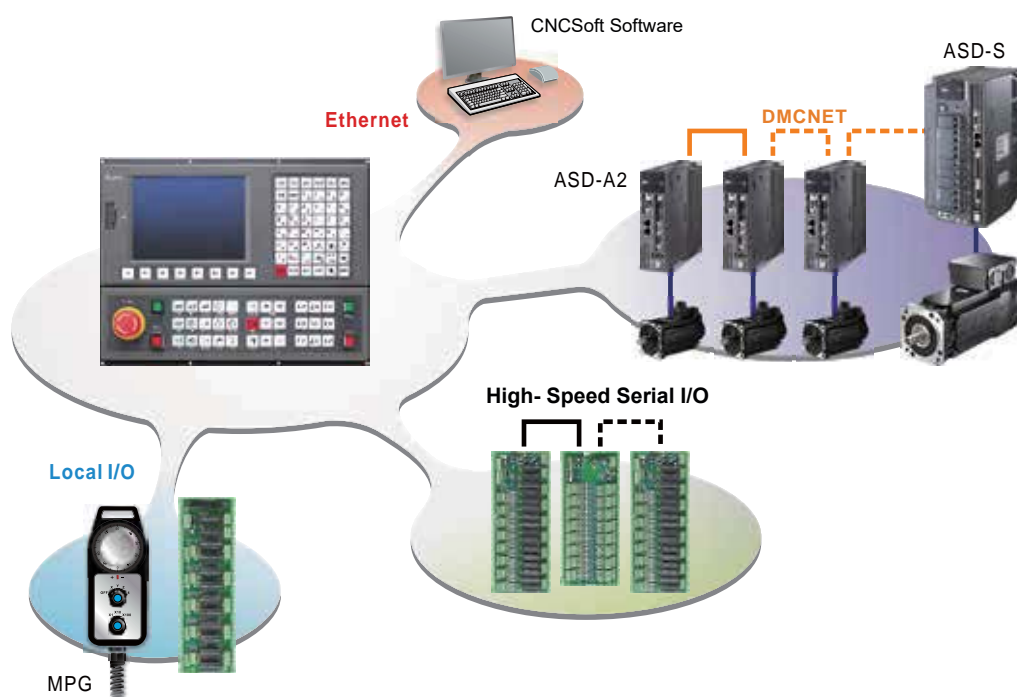

Applications



CNC Machining Centers,
High-speed Tapping Machines

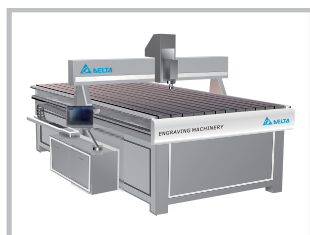

Engraving Machines



CNC Gantry Control Machines



CNC Woodworking Machines

Robot Controller with Servo Drive Integrated ASDA-MS

An Innovative and Comprehensive Development Platform for Robot Control

Complete Robot Solution

- Integrated servo drive and controller in one single unit for real-time motion control with high flexibility and reliability
- Supports various communication protocols
- Built-in with diverse robot control modules
- Up to 10 axes motion control: 4-axis robot + 6 external axes
- Supports 5 kinds of programming languages with IEC 61131-3 standard and the PLCopen motion function block
- Offers DRL Languages for robot application programming
- Supports G-code programming

User-Friendly Robot Software

- IEC61131-3 PLC programming
- DRL programming
- Multiple robot motion settings
- Intelligent robot system calibration
- Real-time monitoring oscilloscope
- Applicable for different types of robots such as SCARA Robots, Delta Articulated Robots and more

System Configuration

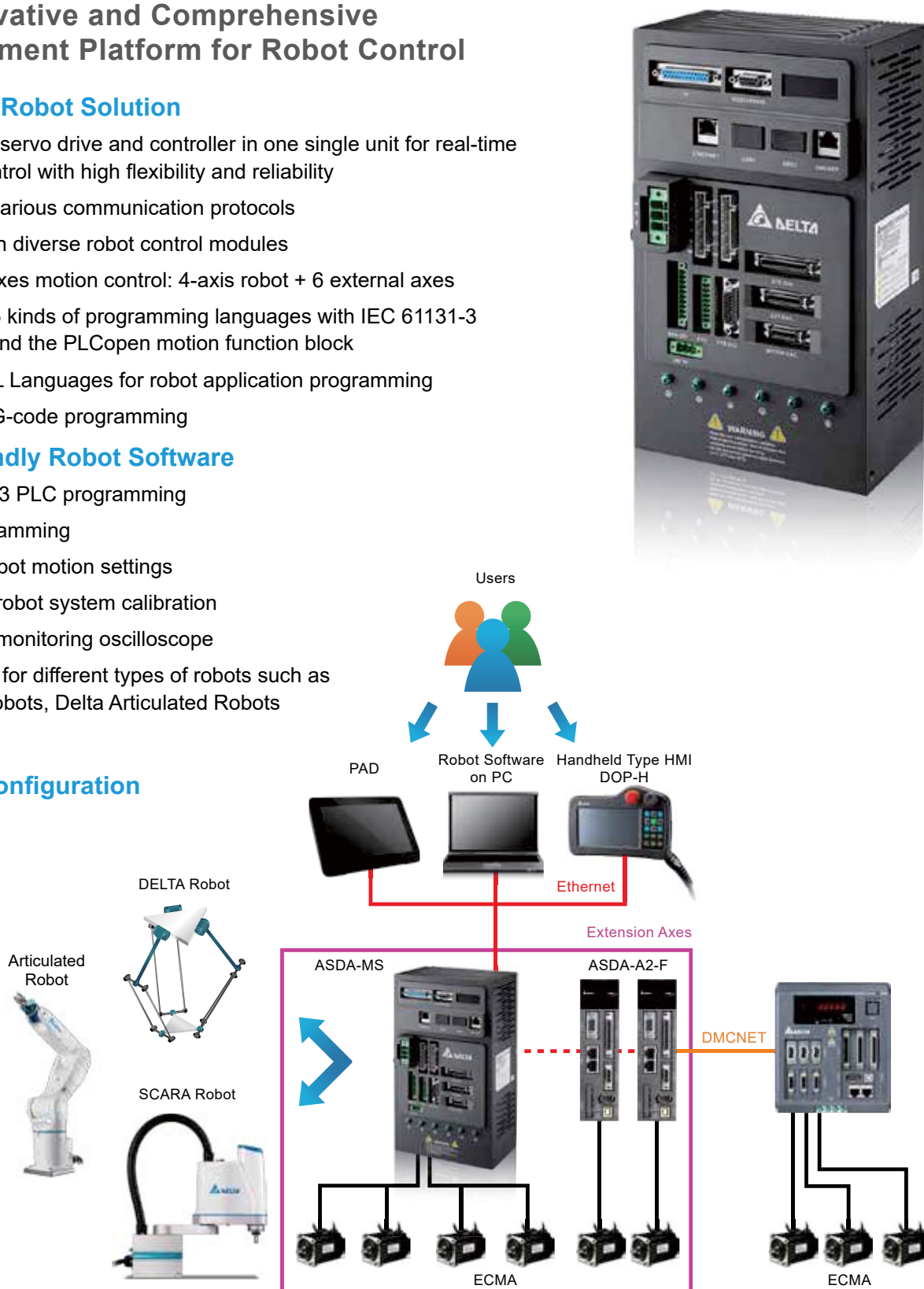

All-in-One Robot Controller

- Integrates motion controller, robot controller and 4 servo drives into one single unit to speed up data transmission, enhance system control performance and dynamically compensate non-linear terms that affect robot motion during robot moving processes, which meets the high speed and high precision requirements of robot or motion control applications
- Provides a variety of tools for implementing required functions and supports different types of robots such as the 4-axis SCARA robot, the Linear DELTA, DELTA robot, and the 2 axes extension via DMCNET for 6-axis articulated robot to meet diverse requirements with flexibility and reliability

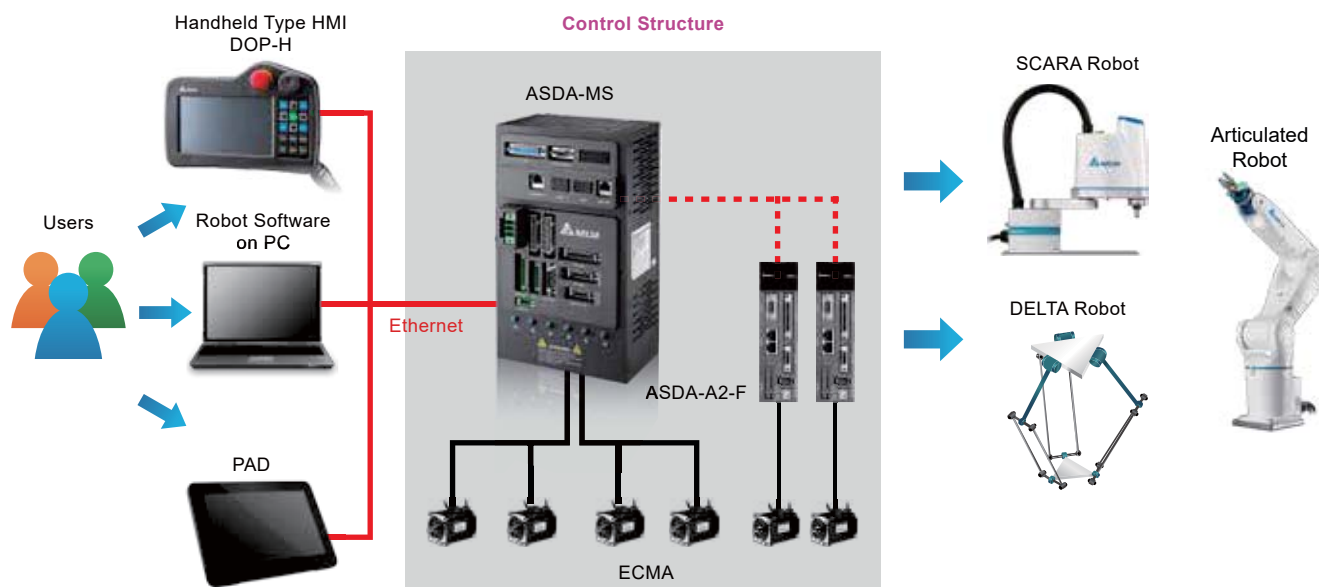

Comprehensive Development Platform

- Provides a comprehensive development platform for customers to design their specific applications, which enhances value-added secondary development and efficiency of various manufacturing techniques
- Meets the requirements for both single robot or workstation applications integrated with Delta's industrial automation products and related robot peripheral devices to create a complete robotic automation solution

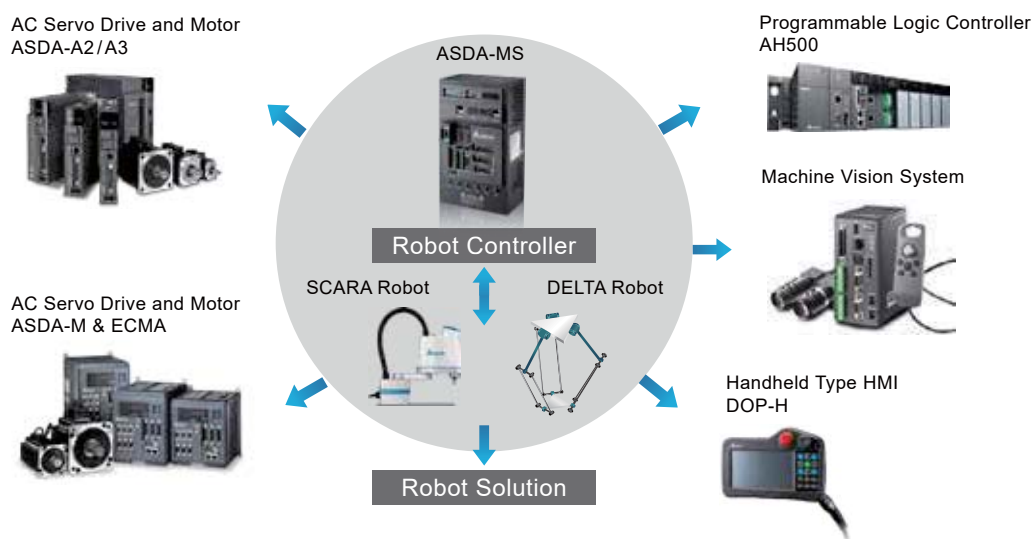

Applications

Industries: Consumer electronics, electrical / electronics, rubber and plastics, packaging, metal fabrication

Techniques: Insertion, screw driving, assembly, glue dispensing, soldering, load and unload, stacking, inspection

Optimum Combination of Display and Controller Controllers with Human Machine Interfaces

HMC Series

7-inch Controller with Widescreen Handheld HMI HMC07-N411H5C5(A)

- 7" 16:9 widescreen 65536 colors TFT
- Display Resolution: 800x480 pixels
- Built-in PLC functions
- Built-in emergency stop switch
- Built-in enable switch (rear side)
- Optional MPG (Manual Pulse Generator)
- Supports SDHC card
- Supports DMCNET
- Compact and lightweight 750g design



7-inch Controller with Handheld HMI HMC08-N500S52

- 7" 65536 colors TFT
- Display Resolution: 800x600 pixels
- Built-in PLC functions
- RS-422 high-speed remote I/O connection
- Supports Ethernet
- Supports SDHC card
- Supports DMCNET
- Supports audio output: MP3, Wav files
- USB Host for direct connection to USB disk, printer, mouse and keypad



8-inch Controller with HMI HMC08-N500S52

- 8" 65536 colors TFT
- Display Resolution: 800x600 pixels
- Built-in PLC functions
- RS-422 high-speed remote I/O connection
- Supports MPG (Manual Pulse Generator) Input
- Supports Ethernet
- Supports SDHC card
- Supports DMCNET
- Supports audio output: MP3, Wav files



Control of a Material Loading/Unloading Robot for Machine Tools

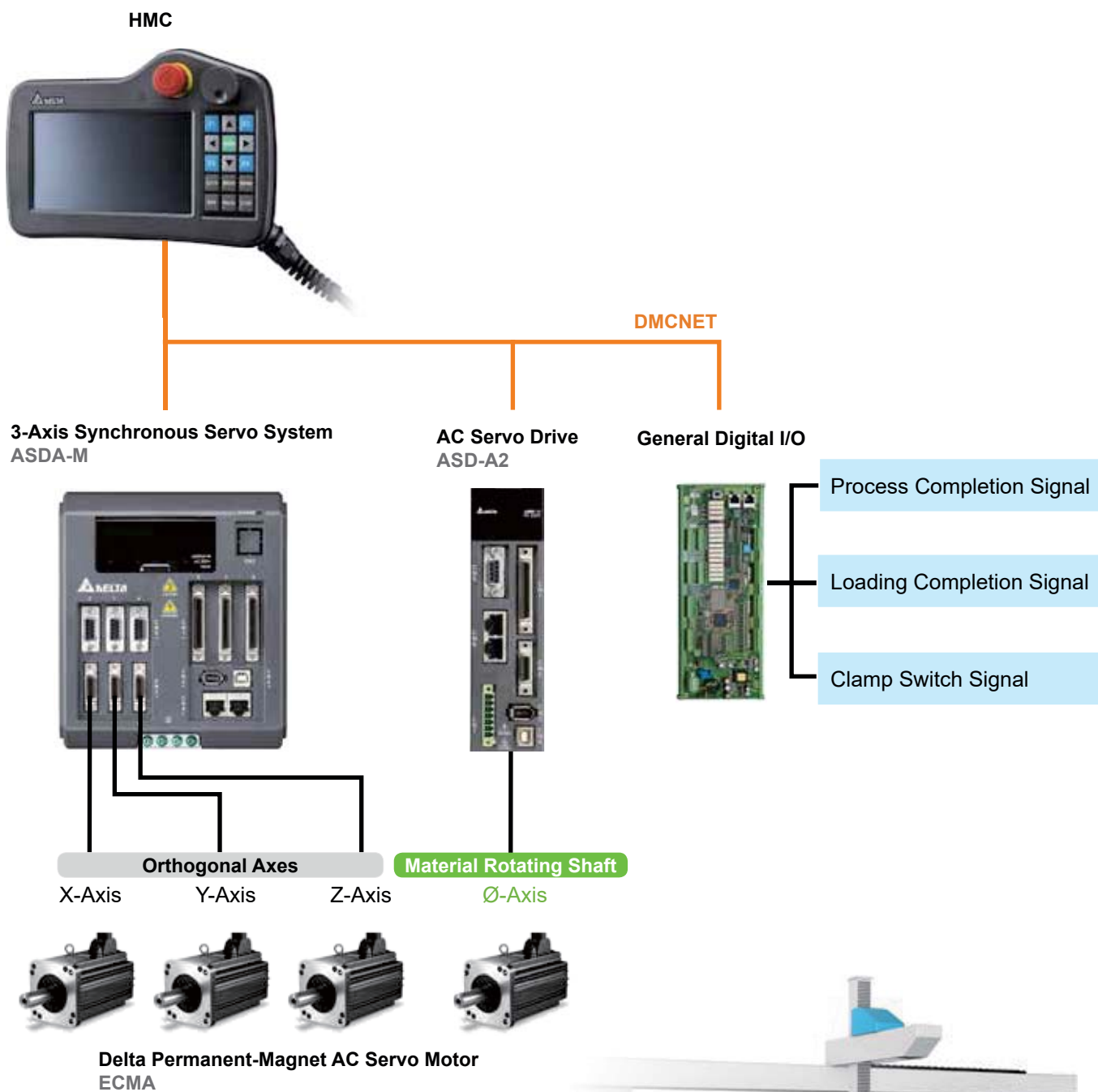

Hot Swappable Mid-range PLC

AH500

The Smart Solution for High-end Machinery and System Integration



- 32-bit dual-core multitasking processor
- Excellent program execution speed: LD: 20ns
- Max. I/O:
 - DIO: Max. 4,352 points
 - AIO: Max. 544 channels
 - RIO: Max. 125,440 digital points/3,920 analog channels
- Program capacity: Max. 1M steps (4 MB)
- Data register (D+L): 512k words
- CPU with built-in fully isolated RS-232 / 422 / 485 ports, Mini USB port, Ethernet port and SDHC card slot (compatible with the memory cards on the market)
- Abundant selection of AIO modules, DIO modules, temperature modules, network modules, pulse-train and DMCNET motion control modules

Modularized Hardware Structure and Highly Integrated Software

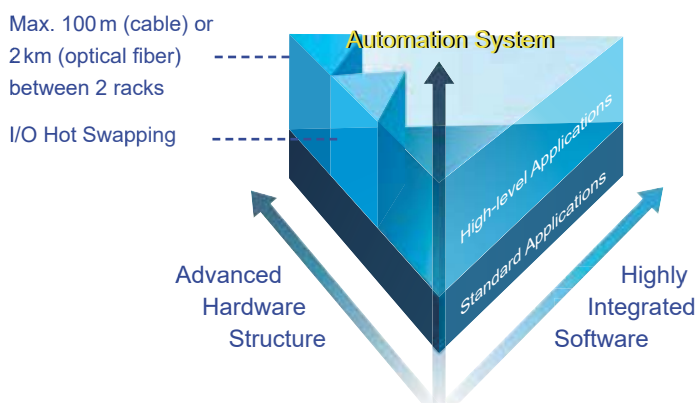

- Highly integrated programming software ISPSOft: Graphical Interface with 5 programming languages
- Enhanced flexibility: Max. 100 m (cable) or 2 km (optical fiber) between 2 local extension racks
- Redundant system and hot-swapping function ensure non-stop system operation for improved maintainability

System Extension Structure

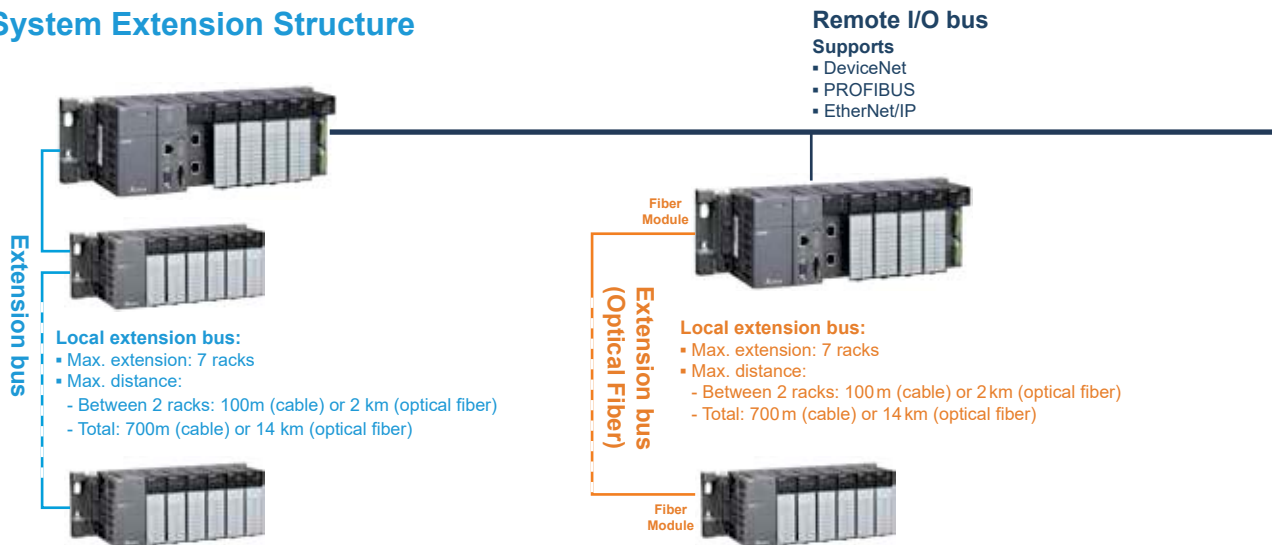

Motion Control Structure

Example: AH20EMC

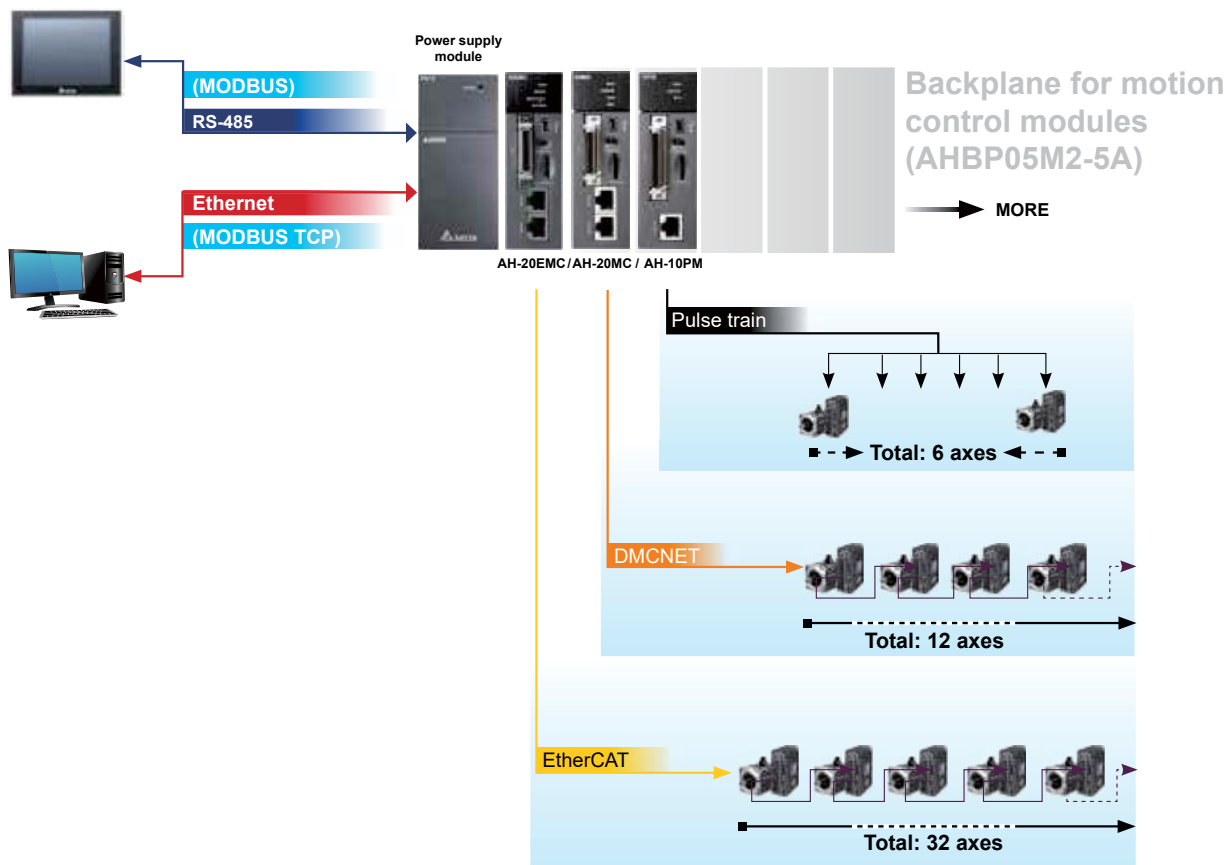

Applications

High-end industrial equipment (textile machines, packaging machines, injection and molding machines, electronics equipment, printing machines, paper making machines, warehousing management systems, logistics management systems) and system integration applications (water treatment, HVAC system, traffic monitoring system)

Redundant CPU

The redundant CPU of the AH Series adopts a reliable redundancy structure, and integrates synchronous modules, Ethernet ports and serial communication interfaces for a more competitive control solution.

AHCPU560-EN2

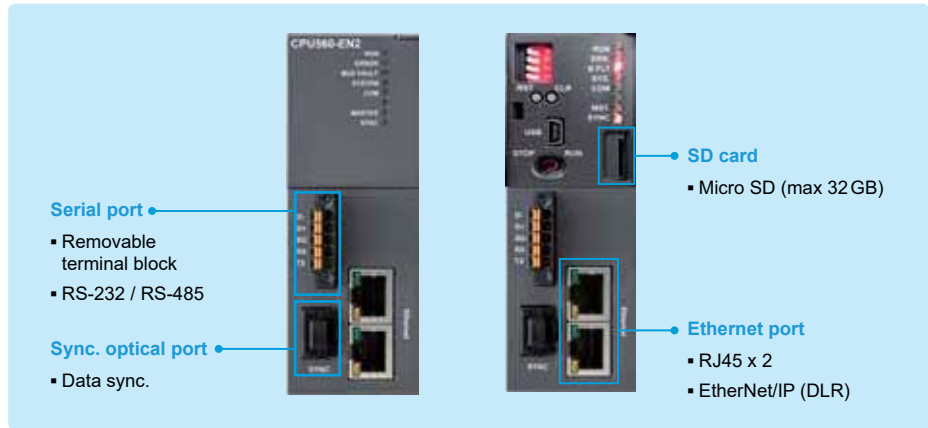

Redundant Backplane

The redundant backplane of the AH Series provides redundant power supply and communication interfaces for a complete control solution.

Redundant main backplane: AHBP04MR1-5A (4-slot)



Redundant expansion backplane: AHBP06ER1-5A (6-slot), AHBP08ER1-5A (8-slot)



Redundant System

Full Redundancy Structure

Redundant CPU	Redundant main backplane	Redundant power	Redundant ext. ports	Ring topology
---------------	--------------------------	-----------------	----------------------	---------------

Modules

Main backplane	Expansion backplane	RTU rack
<ul style="list-style-type: none"> Ethernet module - AH10EN-5A (V3) Serial module - AH10SCM-5A (V3) 	<ul style="list-style-type: none"> DIO AIO (includes temperature modules) Serial modules - AH10SCM-5A, AH15SCM-5A 	<ul style="list-style-type: none"> DIO AIO (include temperature modules)

Tasks

Cyclic	Timer interrupt
--------	-----------------

CPU built-in sync. module

CPU switch-over time: 20 ms

RTU nodes to support expansion backplanes

Standard backplanes available (under some conditions)

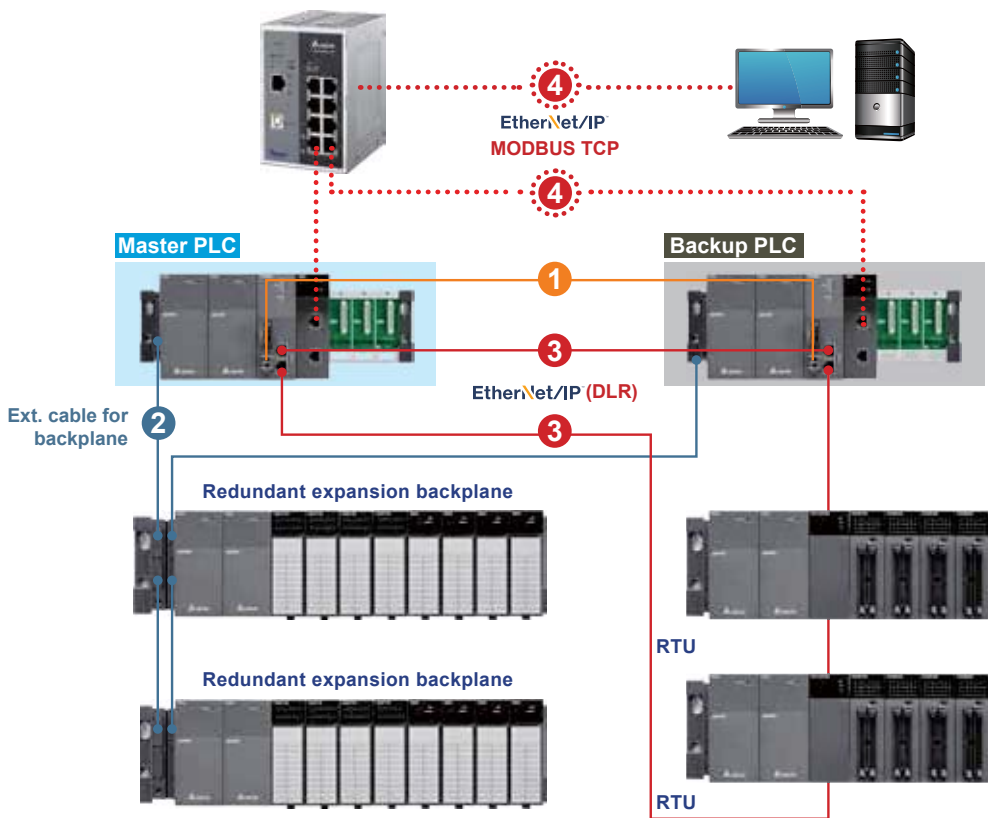

1 Sync. optical fiber

2 Ext. cable for backplane

3 EtherNet/IP ring topology (DLR)

4 Star topology EtherNet/IP, MODBUS TCP

Compact Modular Mid-range PLC

AS

Flexible, Smart, Friendly - The Best Choice for Automated Equipment Control



- Max. I/O: 1,024 points
- Program capacity: 128k steps
- Data register: 60k words
- Max. extension ability: 32 modules
- 32-bit SoC (System on Chip) CPU for high-performance and high-speed computing
- CPU with built-in RS-485 port*2, Mini USB port, Ethernet port, and Micro SD card slot
- Max. 8 axes control via CANopen motion network / max. 6 axes control via pulse control (200 kHz)
- Robust rackless design and patented DIN rail clips for direct plug-in/plug-out module installation and replacement
- Various modules for selection: digital I/O modules, analog I/O modules, load cell modules, temperature measurement modules, serial communication modules, industrial bus modules
- PLC programming software (ISPSoft) for program editing, hardware and network configuration, system diagnosis and axes positioning control

Advanced CPU Performance

High speed execution: up to 40k steps/ms
(Condition: 40% LD instruction / 60% MOV instruction)

LD instruction 25 ns

MOV instruction 0.15 μ s

Floating point operation instruction 1.6 μ s

Trigonometric function instruction 3.5 μ s

Positioning Control - Delta's CANopen Control

- Up to 8-axis CANopen positioning control with AS-FCOPM communication card
- Fast positioning configuration in one initialization instruction without building CANopen data exchange table
- Batch download of programmable servo drive parameters to avoid data loss
- Axis control by instructions to enhance the legibility and maintainability of PLC programs

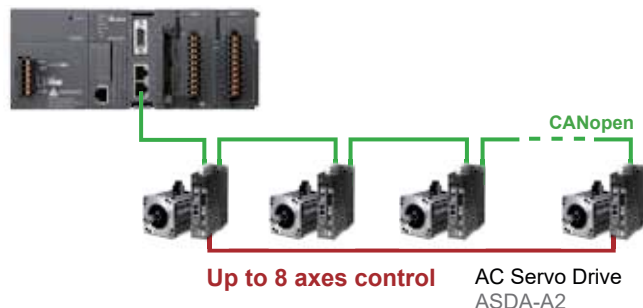

Positioning Control - High-speed Pulse

- AS332T-A / AS332P-A transistor CPU: 6 axes (or 12 channels) 200kHz
- AS324MT-A differential CPU: 2 axes 4 MHz + 4 axes 200kHz
- Supports positioning planning table for fast positioning planning and path simulation
- Choose any given 2 axes for linear and arc interpolation

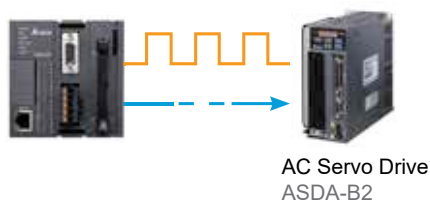

Flexible Network System Configuration

- Supports star, linear network topology for fast expansion and management on production lines
- Compatible with IT network; no independent network or IT technician required
- Combines with Delta's industrial Ethernet solutions to construct IoT for more automation application and industrial upgrades

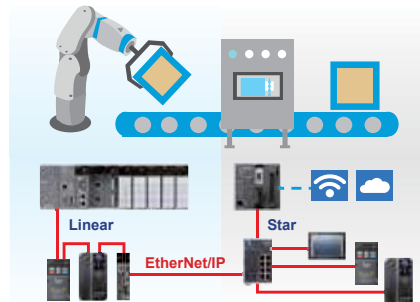

New Programming Software

Various, Convenient Software Wizards for Effortless Planning

Positioning Planning Table

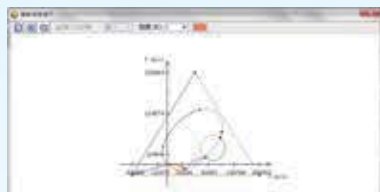

2D simulation

Intuitive 2D track simulation without complicated calculation for real-time path planning

Path list

Multiple combination for positioning modes and tracks
Fast path planning via table-structured planning



Axis parameter setting

Intuitive configuration interface for easy axis parameter setting without manual reference

Complete Diagnosis Tools for Quick and Effective System Monitoring

Data Logger / Tracer

- Real-time monitoring:**
High-speed tracer for fast sampling within 1 scanning cycle
- Stable logging:**
Long-time data logger saves up to 32,768 data records, able to be transferred to SD cards
- Precise data capture:**
Supports a variety of sampling intervals, trigger modes, software settings, and hardware execution
- Convenient comparison:**
Multiple data logs in various data formats can be recorded at the same time
- Efficient data analysis:**
Supports trend display, scaling, arrangement, merge and measurement

- Real-time
- Stable
- Precise

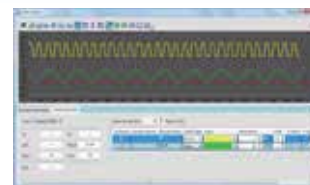

Applications

High-end equipment for electronics manufacturing, machinery processing, food packaging and other industries

High Performance PLC

DVP-EH3

Excellent for OEM Monitoring Solution

High-end model of Delta's DVP-E Series PLC with large program capacity and data registers for demanding and complex applications

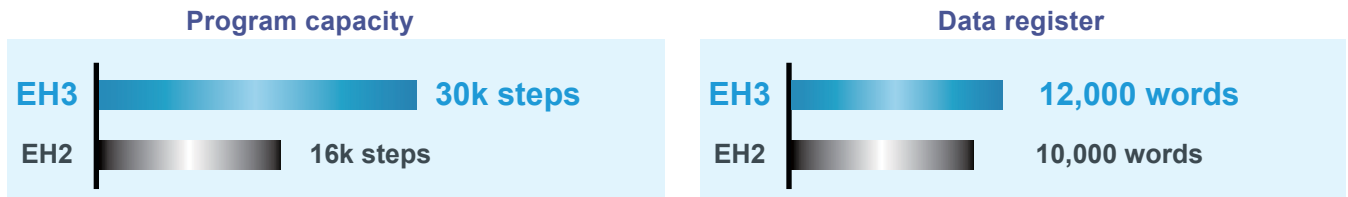

Excellent Motion Control

- High-speed pulse output: max. 4 axes of 200 kHz pulse output (DVP40/48/64/80EH00T3)
- Supports max. 4 hardware 200 kHz high-speed counters
- Various motion control instructions to achieve high-speed and high-precision positioning control for labeling machines, packaging machines, printing machines and more applications
- Linear/ arc interpolation motion control function
- Provides up to 16 external interrupt pointers



Complete Program Protection

- Auto backup function prevents program and data loss even when the battery runs out
- Secondary backup function saves an extra copy of programs and data to enhance program safety
- Up to 4-level password protection protects your source programs and intellectual property

Function Cards

- For RS-232/RS-422 Communication (COM3 Port, DVP-EH3 Series PLC only)



- For Ethernet Communication



- Analog Input/Output



Standard PLC

Analog I/O PLC

DVP-ES2/EX2

Comprehensive Functions for General Applications

Standard PLCs with integrated communication and highly efficient processing ability for your control systems

- Standard PLC DVP-ES2 Series:
 - 16/20/24/32/40/60/80 I/O points for a variety of applications
 - No battery required; RTC function operates for at least one week after power off (hardware version 2.0 or above)
 - DVP32ES2-C model with built-in CANopen (Baud: 1 Mbps)
- Analog I/O PLC DVP-EX2 Series:
 - DVP-20EX2 model:
 - Built-in 12-bit 4 analog inputs / 2 analog outputs; and 14-bit analog I/O extension module
 - Built-in PID auto tuning function for complete analog control solution
 - DVP30EX2 model as temperature and analog I/O PLC
- Program capacity: 16k steps
- Data register: 10k words
- Max. execution speed of basic instructions: 0.35 μ s
- Highly efficient processing ability: 1 k steps of programs can be completed within 1ms
- Max. 100kHz pulse control; specific motion control instructions (mark/masking and instant frequency changing) available for multi-axis applications
- Up to 4-level password protection protects your source programs and intellectual property



reddot design award
winner 2010

Network Type Advanced Slim PLC

DVP-SE

Complete network communication functions for advanced industrial applications

- Program capacity: 16k steps
- Data register: 12k words
- Max. execution speed of basic instructions: 0.64 μ s
- Built-in Ethernet
 - DVP12SE: MODBUS & Ethernet/IP (Explicit message)
 - DVP26SE: MODBUS & Ethernet/IP (Adapter mode, explicit message)
- IP Filter function as firewall for first line protection against malware and network threats
- No battery required; RTC function operates for 15 days after power off
- Supports DVP-S Series modules (left-side and right-side) (DVP26SE only supports right-side modules)



High Performance Slim PLC

DVP-SV2

Best Choice for Slim Type PLC



High-end model of DVP-S Series with larger program capacities and data registers for more demanding and complex applications



Excellent Motion Control









- High-speed pulse output: 4 axes of 200 kHz pulse output
- Supports max. 4 hardware 200 kHz and 2 hardware 20 kHz high speed counters
- Various motion control instructions to achieve high-speed and high-precision positioning control for labeling machines, packaging machines, printing machines and more applications
- Linear/arc interpolation motion control function
- Provides up to 16 external interrupt pointers

Complete Program Protection

- Auto backup function to prevent program and data loss even when the battery runs out
- Secondary backup function saves an extra copy of programs and data to enhance program safety
- Up to 4-level password protection protects your source programs and intellectual property

Supports DVP-S Series modules (left-side and right-side); additional new Ethernet communication command (ETHRW)

High-speed Modules (Left-side)

Network Modules		Analog Input/Output Modules	
<ul style="list-style-type: none"> • DeviceNet Master DVDPNET-SL 	<ul style="list-style-type: none"> • CANopen Master DVPCOPM-SL 	<ul style="list-style-type: none"> • Analog Input DVP04AD-SL 	<ul style="list-style-type: none"> • Analog Output DVP04DA-SL 
<ul style="list-style-type: none"> • Ethernet DVPEN01-SL 	<ul style="list-style-type: none"> • PROFIBUS DP Slave DVPPF02-SL 	<h3>Load Cell Modules</h3> <ul style="list-style-type: none"> DVP01LC-SL DVP02LC-SL DVP201LC-SL DVP211LC-SL DVP202LC-SL 	
<ul style="list-style-type: none"> • RS-422/RS-485 Serial Communication Module DVPSCM12-SL 	<ul style="list-style-type: none"> • BACnet MS/TP Slave Serial Communication Module DVPSCM52-SL 		

Standard Slim PLC

DVP-SS2

Economic and compact model

- Max. I/O: 480 points
- Program capacity: 8 k steps
- Data register: 5k words
- Max. execution speed of basic instructions: 0.35 μ s
- Built-in RS-232 and RS-485 ports (Master/Slave)
- Supports standard MODBUS ASCII/RTU protocol and PLC Link function
- Motion control functions:
 - 4 points of 10 kHz pulse output
 - 8 points of high-speed counters: 20 kHz/4 points, 10 kHz/4 points



Advanced Slim PLC

DVP-SA2

Advanced model supporting high-speed modules (left-side)

- Program capacity: 16k steps
- Data register: 10k words
- Max. execution speed of basic instructions: 0.35 μ s
- Built-in 1 RS-232 and 2 RS-485 ports (Master/Slave)
- Supports standard MODBUS ASCII/RTU protocol and PLC Link function
- No battery required; RTC function operates for 15 days after power off
- Supports DVP-S Series modules (including left-side high-speed modules)
- Motion control functions:
 - 4 points of high-speed pulse output: 100 kHz/2 points, 10 kHz/2 points
 - 8 points of high-speed pulse input: 100 kHz/2 points, 10 kHz/6 points, 1 set of A/B phase 50 kHz
 - Supports 2-axis linear and arc interpolation



Analog I/O Slim PLC

DVP-SX2

Analog model with highly efficient PID control function

- Program capacity: 16k steps
- Data register: 10k words
- Max. execution speed of basic instructions: 0.35 μ s
- Built-in 4 analog inputs/2 analog outputs
- Supports standard MODBUS ASCII/RTU protocol and PLC Link function
- No battery required; RTC function operates for at least one week after power off (hardware version 2.0 or above)
- Supports DVP-S Series modules (including left-side high-speed modules)
- Motion control functions:
 - 4 points of high-speed pulse output: 100 kHz/2 points, 10 kHz/2 points
 - 8 points of high-speed pulse input: 100 kHz/2 points, 10 kHz/6 points
 - Supports 2-axis linear and arc interpolation



Multi-axis Motion Controller

DVP-MC

High Speed, High Precision Motion Control Brings Outstanding Performance

16-axis Motion Controller / 24-axis Motion Controller

DVP10MC11T / DVP15MC11T **New**

Perfect controllers for motion solutions via CANopen communication

- Built-in 16/24 I/O points. Max. 480 I/O points
- Program capacity:
 - DVP10MC: Ladder 16k steps / Motion 1 Mbytes
 - DVP15MC: 20Mbytes
- Built-in Ethernet, RS-232 and RS-485 ports
- Supports standard MODBUS ASCII/RTU protocol
- Flexible industrial networking applications (DeviceNet Master/Slave, CANopen Master/Slave and PROFIBUS DP Slave modules)
- Provides standard communication cables, terminal resistors, distribution boxes and more accessories for easy wiring and connection



DVP-10MC



DVP-15MC **New**

System Configuration

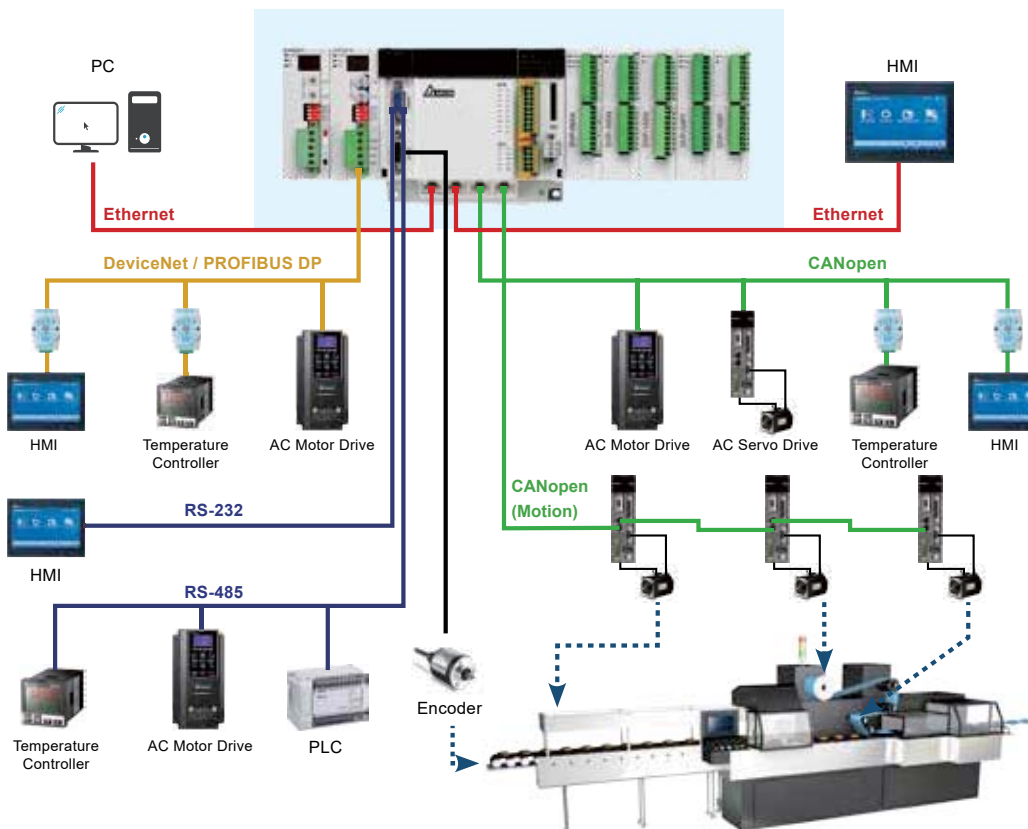

General Motion Controller

DVP-PM

Standard Motion Controller

DVP10PM00M

- Built-in 24 I/O points. Max. 256 I/O points
- Program capacity: 64 k steps
- Data register: 10k words
- Execution speed LD: 0.1375 μ s, MOV: 2.1 μ s
- Built-in RS-232 and RS-485 ports
- 2 / 3 / 4 / 5 / 6 axes linear interpolation motion control
- Highly accurate PWM 200 kHz output, resolution 0.3%
- 8 groups of high-speed captures (mark correction, frequency measurement), comparative output, Mark / Mask function (for bag making)
- Supports standard MODBUS ASCII/RTU protocol
- Motion control functions:
 - High-speed pulse output: built-in 6 sets of A/B phase pulse outputs
 - 2 sets of 200 kHz output, 4 sets of 1 MHz output
 - 6 sets of high-speed counters and hardware digital filter for counting
 - Single-axis motion control function (supports MPG, single-speed and two-speed positioning)
 - Electronic gear function



Advanced Motion Controller

DVP20PM00M/D/DT

- Built-in 16 I/O points. Max. 512 I/O points
- Program capacity: 64 k steps
- Data register: 10k words
- Built-in RS-232 and RS-485 ports
- Compatible with G-code / M-Code
- 3-axis linear/arc/helical interpolation
- Supports electronic cam (2,048 points) function for flying shear and rotary cut applications
- All models can be applied as motion controllers or extension modules
- Supports standard MODBUS ASCII/RTU protocol
- Motion control functions:
 - Built-in A/B phase differential signal outputs: 2 sets (DVP20PM00D)/3 sets (DVP20PM00M) with differential output frequency of max. 500 kHz
 - Supports MPG inputs
 - Single-axis motion control function (supports MPG, single-speed and two-speed positioning)
 - Electronic gear function



Connect Your Work, Step into the Cloud

DOP-100 Series

4.3-inch Widescreen Ethernet HMI New

DOP-103WQ

- 4.3" 16:9 widescreen, 65,536 colors TFT
- Display Resolution: 480 x 272 pixels
- USB Host for direct connection to USB disk, printer, mouse and keypad
- Supports Ethernet
- Supports FTP/ Email / VNC / Web Monitor
- Supports multi-language input



7-inch Widescreen Ethernet HMI New

DOP-107WV

- 7" 16:9 widescreen, 65,536 colors TFT
- Display Resolution: 800 x 480 pixels
- USB Host for direct connection to USB disk, printer, mouse and keypad
- Supports Ethernet
- Supports FTP/ Email / VNC / Web Monitor
- Supports multi-language input



10.1-inch Widescreen Ethernet HMI New

DOP-110WS

- 10.1" 16:9 widescreen, 65,536 colors TFT
- Display Resolution: 1024 x 600 pixels
- USB Host for direct connection to USB disk, printer, mouse and keypad
- Supports SDHC card
- Supports Ethernet
- Supports FTP/ Email / VNC / Web Monitor
- Supports multi-language input



High Color, High Resolution Human Machine Interfaces

DOP-W Series

10.4-inch Large-Size HMI

DOP-W105B

- 10.4" 65536 colors TFT LCD
- Display Resolution: 800x600 pixels
- 1GHz high speed processor
- Supports audio output (MP3, Wav files)
- USB Host for direct connection to USB disk, printer, mouse and keypad
- Supports 2 Ethernet ports
- Supports SDHC card
- Supports video format: MPEG1, MPEG2, WMV



12-inch Large-Size HMI

DOP-W127B

- 12" 65536 colors TFT LCD
- Display Resolution: 1024x768 pixels
- 1GHz high speed processor
- Aluminum enclosure with dark gray mold texturing
- 2 sets of COM ports, supports RS-232/RS-422/RS-485
- USB Host for direct connection to USB disk, printer, mouse and keypad
- Supports 2 Ethernet ports
- Supports SDHC card
- Supports video format: MPEG1, MPEG2, WMV
- Supports audio output: MP3, Wav files (built-in front speaker)



15-inch Large-Size HMI

DOP-W157B

- 15" 65536 colors TFT LCD
- Display Resolution: 1024x768 pixels
- 1GHz high speed processor
- Aluminum enclosure with dark gray mold texturing
- 2 sets of COM ports, supports RS-232/RS-422/RS-485
- USB Host for direct connection to USB disk, printer, mouse and keypad
- Supports 2 Ethernet ports
- Supports SDHC card
- Supports video format: MPEG1, MPEG2, WMV
- Supports audio output: MP3, Wav files (built-in front speaker)



DOP-B Series

4.3-inch Widescreen HMI

DOP-B03S(E)211

- 4.3" 16:9 widescreen, 65536 colors TFT
- Display Resolution: 480x272 pixels
- Supports Ethernet
- USB Client for high-speed data transfer
- USB Host for direct connection to USB disk, printer, mouse and keypad



7-inch Widescreen HMI

DOP-B07S(E)411 / DOP-B07S(E)415

- 7" 16:9 widescreen, 65536 colors TFT
- Display Resolution: 800x480 pixels
- Supports Ethernet
- Supports SDHC card
- USB Client for high-speed data transfer
- USB Host for direct connection to USB disk, printer, mouse and keypad
- Supports audio output: MP3, Wav files



10.1-inch Widescreen HMI

DOP-B10S411 / DOP-B10S(E)615

- 10.1" 16:9 widescreen, 65536 colors TFT
- Display Resolution: 800x480 pixels / 1024x600 pixels
- USB Client for high-speed data transfer
- USB Host for direct connection to USB disk, printer, mouse and keypad
- Supports audio output: MP3, Wav files
- Supports Ethernet
- Supports SDHC card



5.6-inch Standard HMI

DOP-B05S111

- 5.6" 65536 colors TFT
- Display Resolution: 320x234 pixels
- USB Client for high-speed data transfer
- USB Host for direct connection to USB disk, printer, mouse and keypad



7-inch Standard HMI

DOP-B07S(E)515

- 7" 65536 colors TFT
- Display Resolution: 800x600 pixels
- USB Client for high-speed data transfer
- USB Host for direct connection to USB disk, printer, mouse and keypad
- Supports audio output: MP3, Wav files
- The world's first design: the effective display area is the same as 7-inch models, but the panel cutout's dimensions are just the same as 5.6-inch models.
- Supports Ethernet
- Supports SDHC card



8-inch Standard HMI

DOP-B08S(E)515

- 8" 65536 colors TFT
- Display Resolution: 800x600 pixels
- USB Client for high-speed data transfer
- USB Host for direct connection to USB disk, printer, mouse and keypad
- Supports audio output: MP3, Wav files
- Supports Ethernet
- Supports SDHC card



10.4-inch Standard HMI

DOP-B10S511 / DOP-B10E515

- 10.4" 65536 colors TFT
- Display Resolution: 800x600 pixels
- Supports audio output: MP3, Wav files
- Host for direct connection to USB disk, printer, mouse and keypad
- Supports Ethernet
- Supports SDHC card



DOP-B Series

7-inch Widescreen HMI with Delta Professional Functions

DOP-B07PS415

- 7" 16:9 widescreen, 65536 colors TFT
- Display Resolution: 800x480 pixels
- Supports SDHC card
- USB Client for high-speed data transfer
- USB Host for direct connection to USB disk, printer, mouse and keypad
- Supports audio output: MP3, Wav files
- Supports Electronic Cam (E-Cam) function (ASDA-A2)
- Supports G-code download function (DVP-10MC/DVP-20PM/AH20MC)



7-inch HMI with Delta Professional Functions

DOP-B07PS515

- 7" 65536 colors TFT
- Display Resolution: 800x600 pixels
- Supports SDHC card
- USB Client for high-speed data transfer
- USB Host for direct connection to USB disk, printer, mouse and keypad
- Supports audio output: MP3, Wav files
- Supports Electronic Cam (E-Cam) function (ASDA-A2)
- Supports G-code download function (DVP-10MC/DVP-20PM/AH20MC)
- The world's first design: the effective display area is the same as 7-inch models, but the panel cutout's dimensions are just the same as 5.6-inch models



DOP-H Series

7-inch Widescreen Handheld HMI

DOP-H07

- 7" 16:9 widescreen, 65536 colors TFT
- Display Resolution: 800x480 pixels
- Supports SDHC card
- Built-in emergency stop switch
- Built-in enable switch (rear side)
- Serial communication models support RS-485/RS-422
- Ethernet communication models support one Ethernet port
- Optional MPG (Manual Pulse Generator)
- Compact and lightweight 750g design
- Integrated style cables available (5m/10m)



4-Line Text Panel HMI

TP04G-AL-C / TP04G-AL2

- 4.1" STN-LCD
- User-defined function keys available
- Supports RS-232/RS-422/RS-485 ports (TP04G-AL2)
- Password protection function available
- User-defined boot screen available
- Built-in real time clock (RTC)

Dimensions	4.1" (101.8 × 35.24mm)
Resolution	192 × 64
Display Color	Monochrome
Flash Memory	256k bytes
Function Key	10 function keys
Password	Available
Recipe Function	Not available
RTC	Available
Serial COM Port	RS-232 & RS-422/485
Editing Software	TPEditor

4-Line Text Panel HMI

TP04G-BL-C

- 4.1" STN-LCD
- 0~9 numeric keys and user-defined function available
- Built-in RS-232 and RS-422/RS-485 ports
- Supports MODBUS ASCII/RTU modes
- Password protection function available
- User-defined boot screen available
- Built-in real time clock (RTC)

Dimensions	4.1" (101.8 × 35.24mm)
Resolution	192 × 64
Display Color	Monochrome
Flash Memory	256k bytes
Function Key	17 function keys
Password	Available
Recipe Function	Not available
RTC	Available
Serial COM Port	RS-232 & RS-422/485
Editing Software	TPEditor

8-Line Text Panel HMI

TP08G-BT2

- 3.8" STN-LCD
- Resolution: 240x128 dots
- Built-in 1,024KB flash memory
- 24 user-defined function keys
- Built-in RS-232 and RS-422/RS-485 ports
- Supports recipes and macro functions

Dimensions	3.8" (83x41mm)
Resolution	240 × 128
Display Color	Monochrome
Flash Memory	1 M bytes
Function Key	24 function keys
Password	Available
Recipe Function	Available
RTC	Available
Serial COM Port	RS-232 & RS-422/485
Editing Software	TPEditor

Applications

Intelligent control systems for aquaculture, steel sleeve tapping machines, air compressors, plant factories

7-Inch Touch Panel HMI with Built-in PLC

TP70P-RM0

- Adopts the core of DVP-SS2 Series PLC:
program capacity: 2k steps / D device: 5k words
- 7" TFT-LCD
- Touch screen
- Built-in USB port for program upload/download
- Built-in RS-232 and RS-485 ports
- Supports MODBUS ASCII/RTU modes
- Built-in real time clock (RTC)

Dimensions	7" (154 × 85 mm)
Resolution	800 × 480
Display Color	65,535 colors
Flash Memory	64 M bytes
Function Key	Not available
Password	Available
Recipe Function	Not available
RTC	Available
Serial COM Port	RS-232 & RS-485
Editing Software	TPEditor

7-Inch Touch Panel HMI with Built-in PLC

TP70P

- Adopts the core of DVP-SS2 Series PLC:
program capacity: 4k steps / D device: 5k words
- Provides 2 sets of 10kHz high-speed pulse input
- 7" TFT-LCD
- Touch screen
- Built-in USB port for program upload/download
- Built-in RS-485 port*2
- Supports MODBUS ASCII/RTU modes
- Built-in real time clock (RTC)
- Digital and analog I/O terminals available

Dimensions	7" (154 × 85 mm)
Resolution	800 × 480
Display Color	65,535 colors
Flash Memory	64 M bytes
Function Key	Not available
Password	Available
Recipe Function	Not available
RTC	Available
Serial COM Port	2 sets of RS-485
Editing Software	TPEditor

4-Line Text Panel HMI with Built-in PLC

TP04P

- Adopts the core of DVP-SS2 Series PLC:
program capacity: 8k steps / D device: 5k words
- Provides 2 sets of 10kHz high-speed pulse input
- 4.1" STN-LCD
- Provides 0~9 numeric keys with user-defined function
- Built-in USB port for program upload/download
- Built-in RS-485 port*2
- Supports MODBUS ASCII/RTU modes
- User-defined boot screen available
- Built-in real time clock (RTC)
- Digital and analog I/O terminals available

Dimensions	4.1" (101.8 × 35.24 mm)
Resolution	192 × 64
Display Color	Monochrome
Flash Memory	1 M bytes
Function Key	17 function keys
Password	Available
Recipe Function	Not available
RTC	Available
Serial COM Port	2 sets for RS-485
Editing Software	TPEditor



Photoelectric Sensor New

PS-R

- Different sensing range adjustment (Trimmer or TEACH)
- M3 mounting hole, easy to install
- Electrical circuit protection
- IP67 and CE certification



PS-F / PS-L

- Slim and small, easy to install
- Electrical circuit protection
- IP67 and CE certification



PS-M

- Standard size (M18) for mounting
- Sensing range adjustment (TEACH)
- M3 mounting hole, easy to install
- Electrical circuit protection
- IP67 and CE certification



Inductive Proximity Sensor

IS

- Nickel-coated brass
- Standard sensors for detecting ferrous metals
- Electrical circuit protection
- IP67 and CE certification





Fiber Amplifier New

FA

- Light and slim, easy to install
- Dual display, visualized setting
- Easy function setting with buttons
- CE certification



Laser Displacement New

LD

- Aluminum case, strong structure
- Slim and small, easy to install
- High precision, sampling time setting available
- IP67 and CE certification

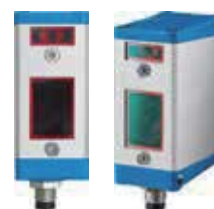

Area Sensor New

AS

- Aluminum case, strong structure
- No dead zone
- Effective aperture angle: less than 2.5 degrees
- IP67 and CE certification



Applications

Electronics Industry, warehouse / logistics, wooden and steel industry, textile industry, food and beverages, equipment, machine, protection and more

Rotary Encoder

HS / ES / EH

Incremental

- Configurable Resolution
- Wide Input Voltage: 5~30V_{DC}
- Resolution: 50~2500 PPR
- Output Form: Open Collector, Line Driver, Push Pull
- HS / ES Outer Diameter of Solid Shaft :36.6 mm, 50 mm
- EH Outer Diameter of Hollow Shaft: 36.6 mm, 50 mm



HS5 / HS3 (Magnetic)

EH5 / EH3 (Optical)

ES5 / ES3 (Optical)

Applications

Label printing machines, detecting machines, elevators, bottling machines, cutting machines, elevator doors, testing/inspection machines

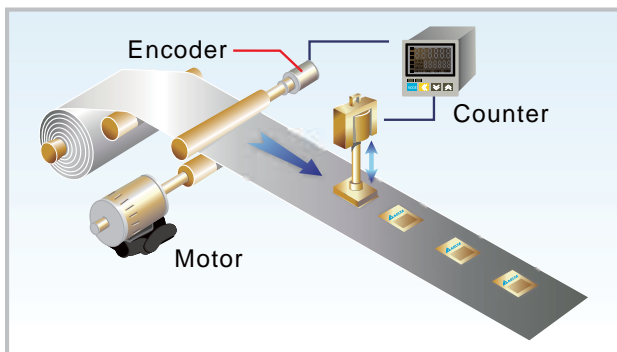

Label Printing Machines

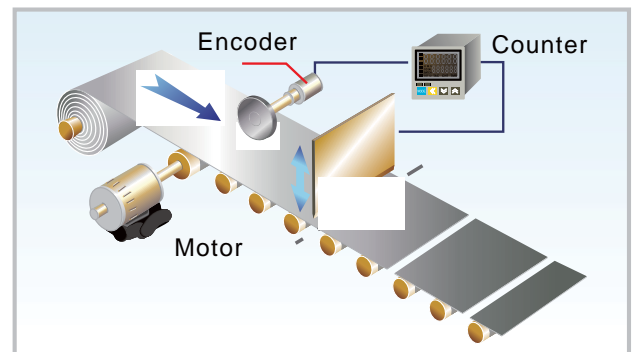

Cutting Machines

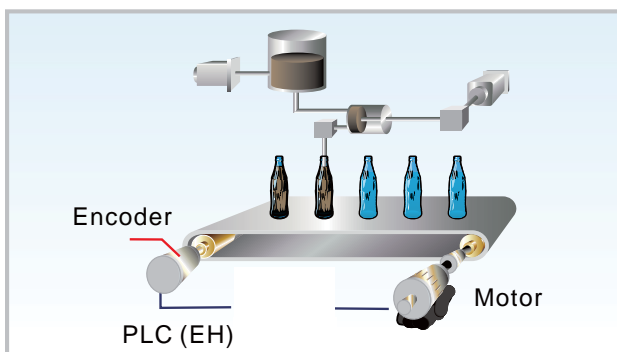

Bottling Machines

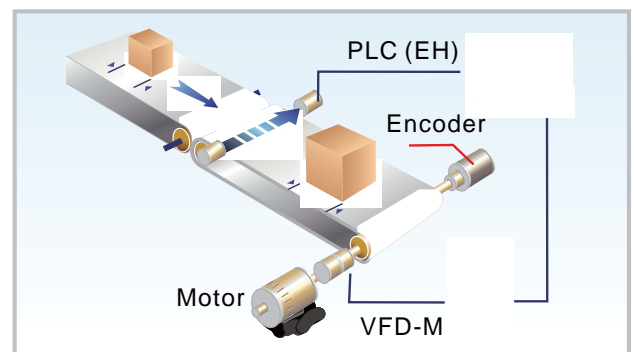

Testing/Inspection Machines

Handheld Barcode Scanner New

DAH

Wide Target Area, Fast and Reliable Capture

- Fast code capture speed without aiming precisely
- Easy to read barcodes under low contrast, optical noise, uneven exposure or damaged conditions
- Easy commands for users to set up:
 - Manually adjust illumination based on various environment
 - Supports single and multiple trigger modes
 - Manually select barcode types based on user's demands
 - Users can self-define exported contents of the scanning codes for flexible data acquisition
- Robust design: drop impact resistance at 1m high
- No detachable components to save maintenance cost



Applications

Food and beverage packaging, electrical machines, printing machines, pharmaceutical machinery, automated product line

Advanced Decode Algorithm for Excellent Reading Performance

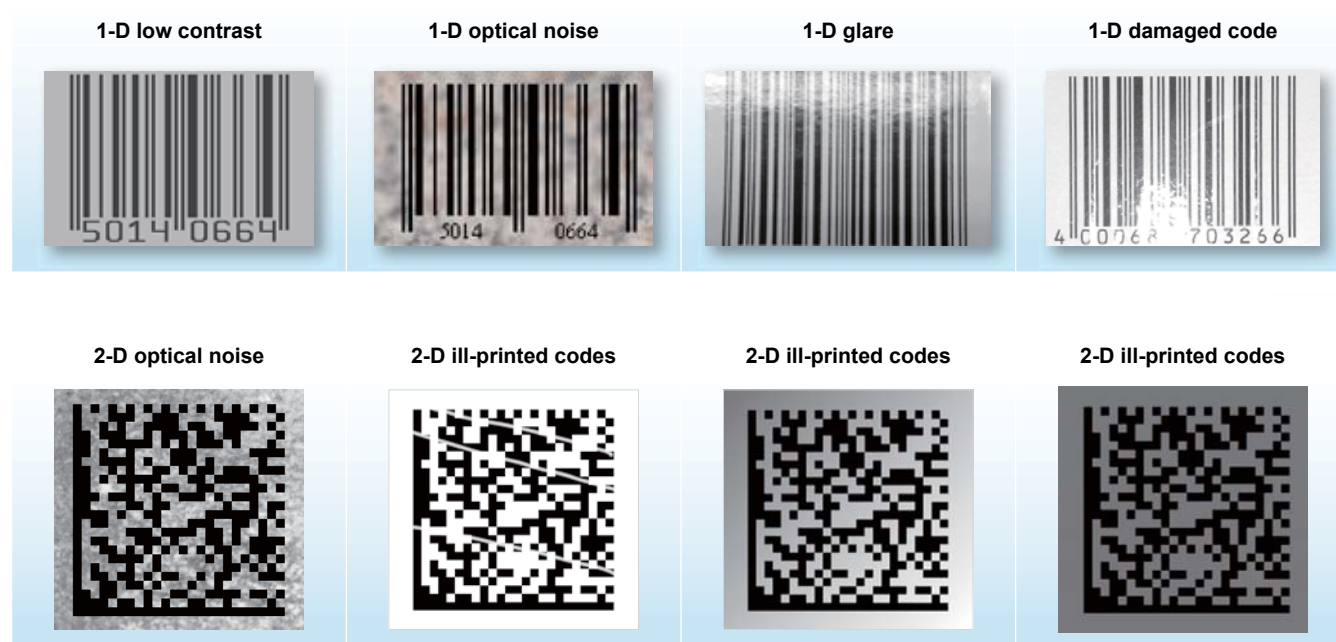

Advanced Intelligent Temperature Controller

DT3

High Speed. High Precision. High Performance
Next Generation Multifunction Temperature Controller



Applications

Solar panel manufacturing, food and beverage packaging, pharmaceuticals, semiconductors, rubber and plastics, high-tech electronics industries, air-conditioning and heating system

Remote Control

Sets DT3 temperature via analog output of host controller

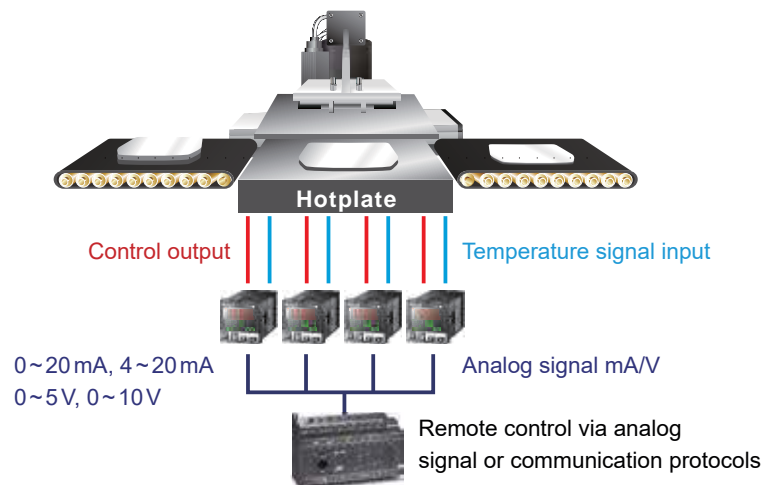

Various Control Modes

- Auto Tuning
- FUZZY
- Manual
- ON/OFF
- PID Process Control
- Self Tuning

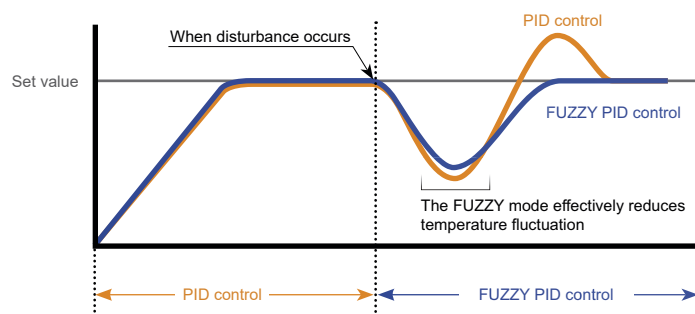

User-defined Function Keys

- Control Modes Selection
- Alarm Clearing
- Controller ON/OFF
- Start PID
- Save Menu
- Process Control ON/OFF



Large Tri-color LCD Display

The 1st Tri-color LCD temperature controller in Taiwan



Heater Disconnection Detection

Measurable up to 100A



Point-to-Point Control (Proportional Output mA/V)

Sets the Present Value by point-to-point control



Retransmission Output

0~20mA, 4~20mA/0~5V, 0~10V
Present Value Transmission mA/V

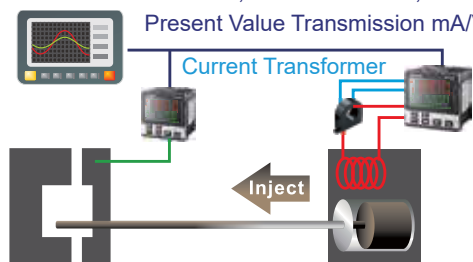

Dual-output Control

- Preset temperature is rapidly attained using two sets of outputs for heating and cooling control
- AT function is used to automatically calculate two sets of PID parameters, one for heating and one for cooling

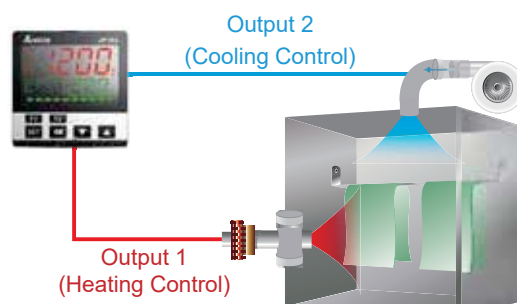

Temperature Sensor Input

- Thermocouple: K, J, T, E, N, R, S, B, L, U, TXK
- Platinum Resistance Thermometer: Pt100, JPt100, Cu50, Ni120
- Analog Input: 0~5V, 0~10V, 0~20mA, 4~20mA, 0~50mA

Output

Relay, current 4~20mA, pulse voltage, analog voltage 0~10V

Intelligent Temperature Controller

DTK

- Thermocouple: K, J, T, E, N, R, S, B, L, U, TXK (Supports max. 8 sets of input)
- Platinum Resistance: Pt100, JPt100 (Supports max. 6 sets of input)
- RTD: Cu50, Ni120
- Analog Input: AC 100~240V, 50/60Hz
- Output: Relay, current 4~20 mA, pulse voltage
- Control Mode: ON-OFF, PID, manual
- MODBUS communication: Optional
- 1 set of alarm output (2 sets of alarm outputs are optional), 9 alarm modes
- Certification: CE, UL



Standard Temperature Controller

DTA

- Thermocouple: K, J, T, E, N, R, S, B, L, U, TXK
- Platinum Resistance: Pt100, JPt100
- RTD: Cu50
- Analog Input: N/A
- Output: Relay, current, pulse voltage
- Control Mode: ON-OFF, PID, manual
- MODBUS communication: Optional
- 2 sets of alarm outputs, 12 alarm modes
- Dimensions: 48x48, 48x96, 72x72, 96x48, 96x96 (mm)
- IP66 protection
- Certifications: CE, UL



Advanced Temperature Controller

DTB

- Thermocouple: K, J, T, E, N, R, S, B, L, U, TXK
- Platinum Resistance: Pt100, JPt100
- Analog Input: 0~5V, 0~10V, 0~20 mA, 4~20 mA, 0~50 mA
- Output: Relay, current 4~20 mA, pulse voltage, analog voltage 0~10V
- Control Mode: ON-OFF, PID, manual, PID process control
- MODBUS communication: Built-in
- 2 sets of alarm outputs, 18 alarm modes
- Dimensions: 48x24, 48x48, 48x96, 96x96 (mm)
- IP66 protection
- Certifications: CE, UL



Modular Temperature Controller

DTC

- Thermocouple: K, J, T, E, N, R, S, B, L, U, TXK
- Platinum Resistance: Pt100, JPt100
- Analog Input: 0~5V, 0~10V, 0~20 mA, 4~20 mA, 0~50 mA
- Output: Relay, current 4~20 mA, pulse voltage, analog voltage 0~10 V
- Control Mode: ON-OFF, PID, manual, PID process control
- MODBUS communication: Built-in
- 2 sets of alarm outputs, 18 alarm modes
- Certifications: CE, UL



Basic Temperature Controller

DTD

- Thermocouple: K, J, T, E, N, R, S, B, L, U, TXK
- Platinum Resistance: Pt100, JPt100, Cu50
- RTD: Cu50
- Analog Input: 0~70 mV, 0~5V, 0~10V, 0~20 mA, 4~20 mA
- Output: Relay, current 4~20 mA, pulse voltage, analog voltage 0~10 V
- Control Mode: ON-OFF, PID, manual, PID process control
- 1 set of alarm outputs, 8 alarm modes
- Dimensions: 48x48, 48x96, 72x72 (mm)
- IP66 protection
- Certification: CE



Multi-Channel Modular Temperature Controller

DTE

- Thermocouple: K, J, T, E, N, R, S, B, L, U, TXK (Supports max. 8 sets of input)
- Platinum Resistance: Pt100, JPt100 (Supports max. 6 sets of input)
- RTD: Cu50, Ni120
- Analog Input: N/A
- Output: Relay, current 4~20 mA, pulse voltage, analog voltage 0~10 V
- Control Mode: ON-OFF, PID, manual, PID process control
- MODBUS communication: Built-in
- 2 sets of alarm outputs, 18 alarm modes
- Certifications: CE, UL



Standard Multifunction Pressure Sensor

DPA

High-Precision Pressure Sensor with comprehensive functions

- 3 sets of color display
- Easy code display
- Various unit conversions
- Various output modes
- Supports RS-485 communication and analog output
- 10 sets of output response time setup
- Safety control function
- Energy-saving mode



Basic Multifunction Pressure Sensor

DPB

Miniature Pressure Sensor for Easy Integration and Cost-saving

- Various unit conversions
- 10 sets of output response time setup
- Various output modes
- 3 sets of color display
- Fast zero reset
- Safety control function
- Easy code display



Flow Switch New

DFM

High-precision and Multiple Air Flow Range

- Bidirectional flow amount measurement, unaffected by fluid direction
- Embedded Laminar Flow Element (LFE), no extra straight pipes needed for stabilizing air flow
- Easy installation and maintenance
- High quality LCD display
- Supports analog output



Applications

Food and beverage packaging, electronic manufacturing, rubber and plastic welding, Laser Beam Machining (LBM), factory air compressor (for energy saving), nitrogen generator, air compressor flow record and detection

Valve Controllers

DTV

Smart and Multifunctional Valve Controller

- Single key to switch between auto/manual modes
- Left-shift key for easy and quick parameter setting
- Real-time output displays valve openness in percentage form
- Control mode designed for the features of electronic valves
- 2 sets of alarm outputs, supports 17 alarm modes
- MODBUS communication: Built-in



Timer/Counter/Tachometer

CTA

All in One

- Simultaneous counting and timing in the mixed mode
- 6-digit LCD display
- Max. counting speed: 10 Kpps
- NPN or PNP input signals
- Pre-scale function
- Counting modes: 1-stage, 2-stage, batch, total, dual
- MODBUS communication: Optional



Applications

Food packaging machines, label printing machines, fixed length cutting machines, logistics industry, electronics industry

Label Printing Machine

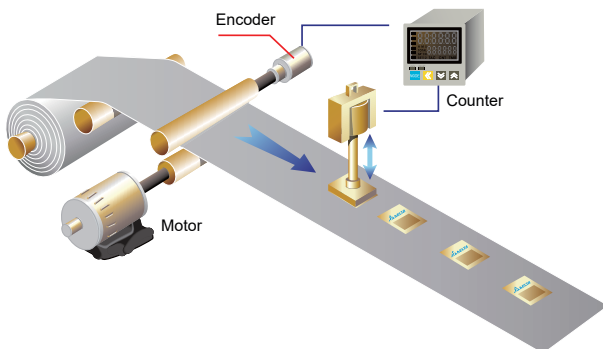

Fixed Length Cutting Machine

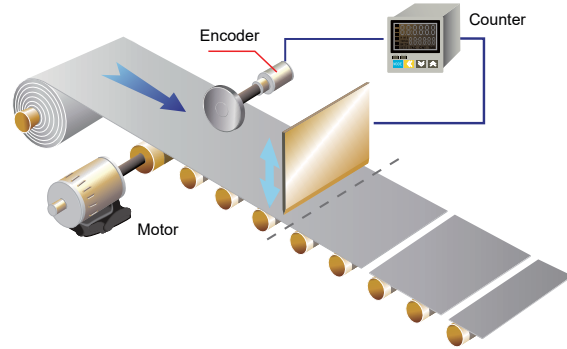

Power Meter

DPM

High Accuracy Solution for Reliable Power Monitoring

Delta Multifunction Power Meter DPM Series precisely measures various electrical energy and power quality parameters, including power factors, harmonics, and current/voltage unbalance. With functions such as off-limit alarms, history logs, communication quality and monitoring, it is suitable for power-critical applications. The DPM-C530, DPM-C520 and DPM-C520W are certified with CE and UL.



High Precision Power Measurement

- Precise measurement of bidirectional electrical energy and power parameters, Class 0.5S meeting IEC62053 and CNS14607 standards
- Supports power quality measurement, total and 31st individual harmonic distortion, voltage and current unbalance, and more
- The DPM-D520I supports 63A current for direct measurement, no current transformer (CT) required

Easy Operation and Installation

- Two mounting clips hold the meter in place, no other tools required
- White-light widescreen LCD with resolution of 198 x 160 dots (DPM-C530)
- Language customization: Traditional Chinese, Simplified Chinese and English (DPM-C530)

Event Alarms and History Logs

- The DPM-C530 / D520I keeps max. 2 months of energy measurement values for history analysis. Up to 17 power parameters selectable for recording different time intervals (e.g. recording 17 electricity parameters every 5 minutes, for up to 2 months)
- DPM-C530 / D520I: 29 types of built-in event alarms for up to 500 event records
DPM-C520: 10 types of built-in event alarms
- The DPM-C520W supports 802.11 b/g/n wireless communication. The DPM-C530 supports BACnet MS/TP protocol
- Built-in RS-485 communication port supports MODBUS protocol, and all measurement values can be transmitted to the PLCs via communication

Parameter Grouping

The parameter grouping function allows faster data transmission and reading by PLCs to improve efficiency and performance

Applications

The DPM-C530 / C520 / C501L are suitable for: energy management, medium or low voltage distribution system, smart switch cabinet, energy management system, factory automation system, building automation system, railway energy management system, electric heating system, wind power system, energy storage system, electric grid measurement, and energy quality analysis

The DPM-C520W is suitable for: elevators, warehouses, semiconductor plants, high-ceiling plants, hospitals, and equipment with mobility

The DPM-D520I is suitable for: industrial machines, communication base station, IIoT equipment, and areas where CT is difficult to install with current lower than 63A

Multi-factories Energy Management and Integrated Application

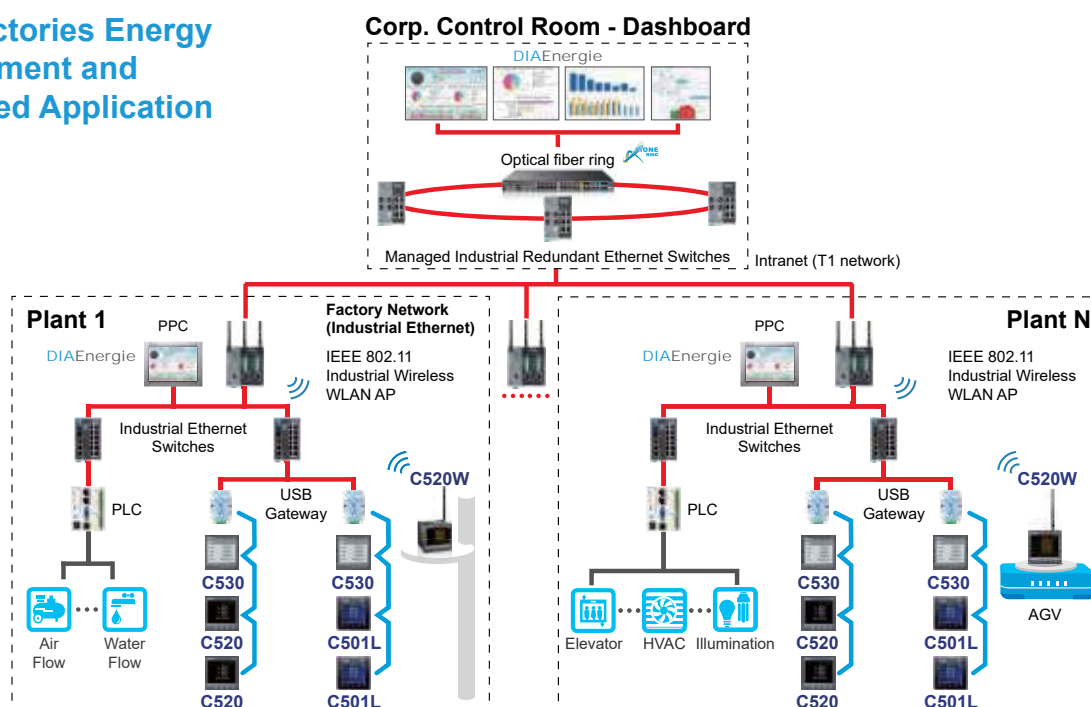

Factory Automation - Energy Consumption Analysis of Production Line

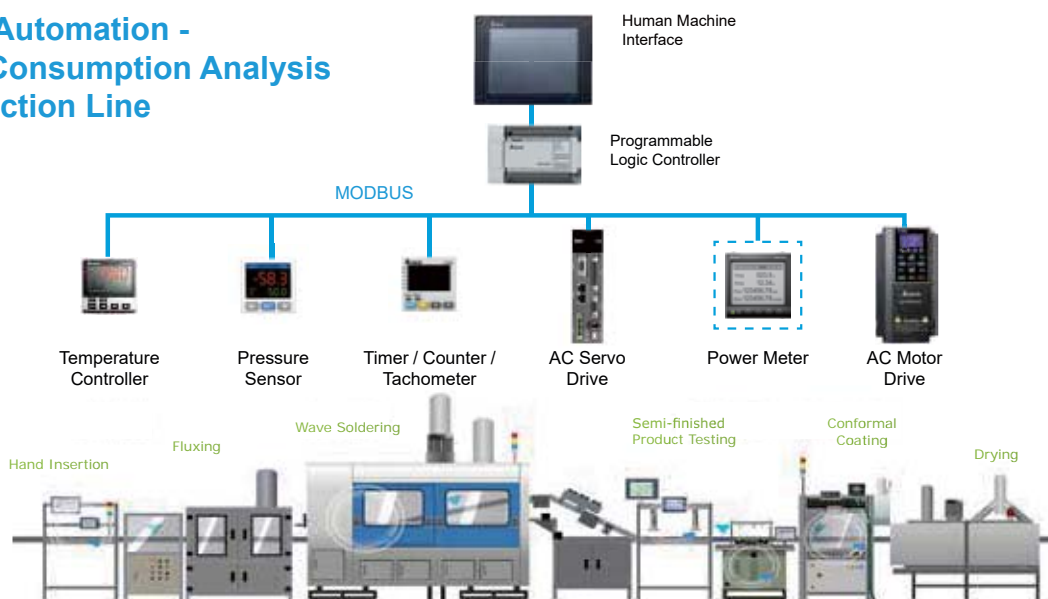

Machine Vision System

DMV2000

Speed, Precision and Humanization - Smart Visual Inspection



- Multiple cameras work synchronously in parallel processes to enhance efficiency and save development costs
- Image auto correction and lens distortion correction function
- User-friendly operation interface
- Smart operation process and interface for faster programming
- Built-in multi-functional developing tools
- Provides industrial networking module, digital I/O and flash control module for various applications
- Superior hardware specifications compared to same grade products. Achieves high-speed processing
- High-speed cameras with CameraLink interface
- Ethernet, RS-232, RS-485 interfaces for data output
- With high industrial standards, stability better than PC-based system
- Built-in communication system connected by PLC, no need for extra programming
- Self-defined display and operation interfaces in operation mode

Product Types

Two types for different applications

- Standard model: 2 or 4 cameras connectable; high performance and big storage
- Basic model: Maximum 2 cameras connectable; supports GigE camera

* Basic model will be released in Q4, 2018

Applications

Food and beverage packaging, electrical/electronics, printing machines, pharmaceuticals, Vision Guided Robotic System (VGRS), robot/automated production lines

Advanced Functions

Functions				
2D platform positioning	√	Edge position tracing	√	
Pattern matching	√	Edge width tracing	√	
Shape matching	√	Stain inspection	√	
Edge angle	√	OCV	√	
Edge counting	√	Subtle inspection	√	
Edge pitch	√	Color inspection	√	
Edge position	√	Barcode identification	√	
Edge width	√	QR code identification	√	
Area	√	PC applications	Off-line simulation	√
Blob	√		Program upload/ download	√
Image intensity	√		Software update	√

High-speed Cameras with CameraLink Interface

Supports high-speed CameraLink Full configuration with maximum frame rate up to 690 M Bytes/sec.
Supports maximum 12M pixels in gray scale using standard CameraLink cameras

Resolution (Mega Pixels)		0.3M	2M	4M	5M	12M
Level	Mono	√	√	√	√	√
	Color	√	√	√	√	√
Frame Rate		480 fps	295 fps	159 fps	35 fps	50 fps
Pixel Dimensions (Horizontal x Vertical)		642 × 484	2048 × 1088	2048 × 2048	2448 × 2048	4096 × 3072
Sensor Size		1/3"	2/3"	1"	2/3"	1.76"
Pixel Size (Horizontal x Vertical)		7.4 × 7.4 μm	5.5 × 5.5 μm	5.5 × 5.5 μm	3.45 × 3.45 μm	5.5 × 5.5 μm
Lens Mount		C Mount	C Mount	C Mount	C Mount	M42



Machine Vision System

DMV1000

Intelligent Human Visual Inspection System
for a Variety of Applications



- User-friendly operation interface for a quick system setup
- Flowchart programming interface saves development time
- Built-in multi-functional developing tools save users from complex programming
- Offers versatile digital I/O terminals
- Compact and light, saves wiring and space
- Hardware specification meets high-speed processing requirements and offers exceptional performance better than competing products
- Supports standard FireWire 1394 Series CCD
- Provides a complete product line-up including lighting and lenses
- Compatible with Ethernet and RS-232/485 communication interfaces for a quick link up with external devices
- Supports SD card
- Meeting a high industrial standard, stability better than PC-based system

Applications

Food and beverage packaging, electrical/electronics, printing machines, pharmaceuticals, Vision Guided Robotic System (VGRS), robot/automated production lines

• Bottle Cap Position Identification

Identifies the bottle capping position

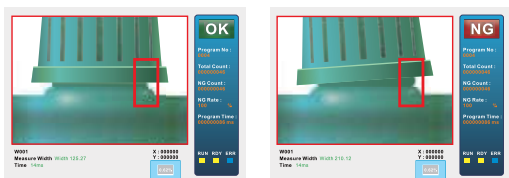

• Direction Identification

Inspects the direction of work pieces conveyed on a production line

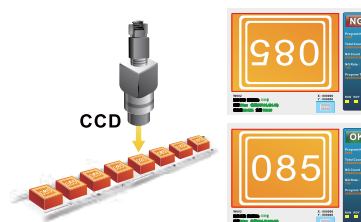

• Beverage Packing Inspection

Inspects the liquid level of each bottle

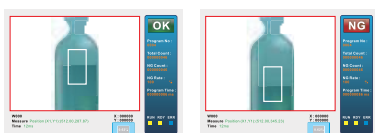

• Character Inspection

Inspects the characters on electronic devices

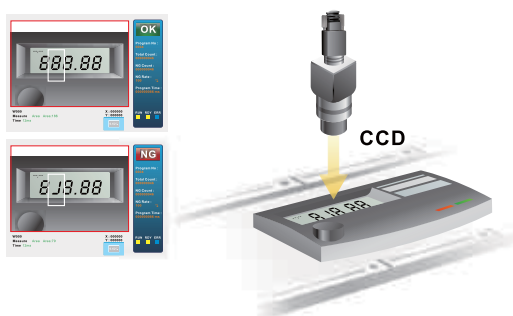

• Luminance Inspection

Inspects LED luminance automatically

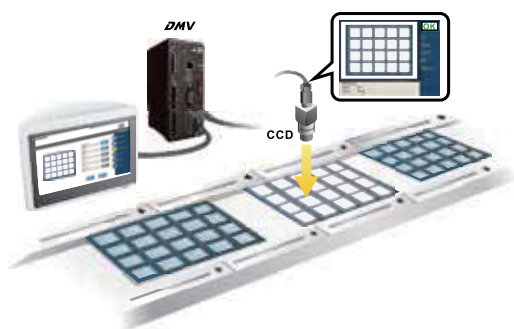

• Position Identification

Inspects the position of IC components on PCBs

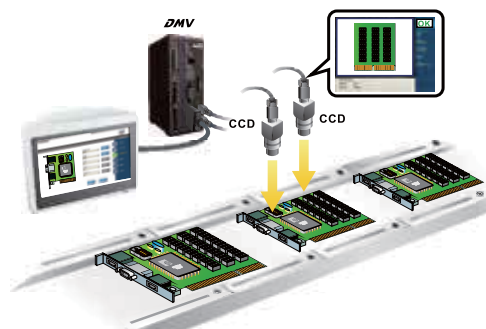

• Module Inspection

Inspects mobile phone modules such as touch screens and buttons

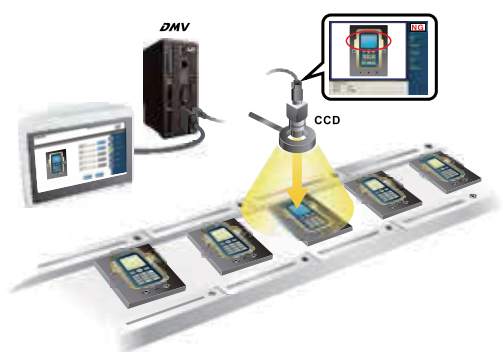

• Object Counting

Counts the quantity of objects in a basket or carton

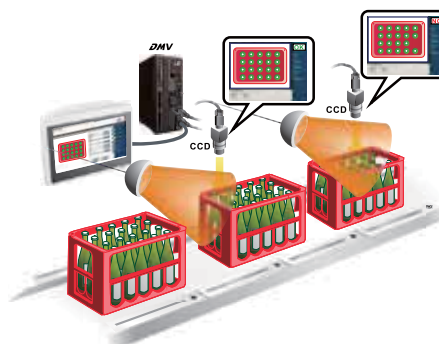



Industrial Power Supply

The World's Number One in Industrial Power Solutions

DIN Rail Models

CliQ, CliQ II, CliQ III, CliQ M, Lyte, Chrome, Sync, DVP

CliQ	Model Name	Output Voltage	Output Power
	DRP012V015W1AZ	12V	15W
	DRP012V030W1AZ		30W
	DRP012V060W1AA		60W
	DRP012V100W1AA		100W
	DRP-24V48W1AZ	24V	48W
	DRP024V060W1AZ		60W
	DRP024V060W1AA		60W
	DRP024V120W1AA		120W
	DRP024V240W1AA		240W
	DRP024V480W1AA		480W

CliQ III	Model Name	Output Voltage	Output Power
	DRP-24V120W1CAN	24V	120W
	DRP-24V240W1CAN		240W
	DRP-24V480W1CAN		480W

CliQ II	Model Name	Output Voltage	Output Power
	DRP024V060W1BN	24V 1-Phase	60W
	DRP024V060W1NZ		60W
	DRP-24V100W1NN		91.2W
	DRP024V120W1BN		120W
	DRP024V240W1BN		240W
	DRP024V480W1BN		480W
	DRP-24V120W2BN	24V 2-Phase	120W
	DRP-24V240W2BN		240W
	DRP024V060W3BN	24V 3-Phase	60W
	DRP024V120W3BN		120W
	DRP024V240W3BN		240W
	DRP024V480W3BN		480W
	DRP024V960W3BN	48V	960W
	DRP048V060W1BN		60W
	DRP048V120W1BN		120W
	DRP048V240W1BN		240W
	DRP048V480W1BN		480W

CliQ M	Model Name	Output Voltage	Output Power
	DRM-24V80W1PN	24V	81.6W
	DRM-24V120W1PN		120W
	DRM-24V240W1PN		240W
	DRM-24V480W1PN		480W
	DRM-24V960W1PN		960W

Lyte	Model Name	Output Voltage	Output Power
	DRL-24V120W1AA	24V	120W
	DRL-24V240W1AA		240W
	DRL-24V480W1AA	48V	480W
	DRL-48V120W1AA		120W

Chrome	Model Name	Output Voltage	Output Power
	DRC-5V10W1AZ	5V	7.5W
	DRC-12V10W1AZ	12V	10W
	DRC-12V30W1AZ		25.2W
	DRC-12V60W1AZ		54W
	DRC-12V100W1AZ		72W
	DRC-24V10W1AZ	24V	10W
	DRC-24V10W1HZ		10W
	DRC-24V30W1AZ		30W
	DRC-24V60W1AZ		60W
	DRC-24V100W1AZ		91.2W

CliQ II Modules	Model Name	Output Voltage	Output Power
Redundancy Module	DRR-20N	24V	20A
	DRR-40N		40A
DC-UPS Module	DRU-24V40ABN		40A
	DRU-24V10ACZ		10A
Buffer Module	DRB-24V020ABN		20A
	DRB-24V040ABN		40A

Sync	Model Name	Output Voltage	Output Power
	DRS-5V30W1NZ	5V	15W
	DRS-5V50W1AZ		30W
	DRS-5V50W1NZ	12V	25W
	DRS-12V50W1NZ		48W
	DRS-24V30W1AZ		30W
	DRS-24V30W1NZ		30W
	DRS-24V50W1NZ		50W
	DRS-24V100W1AZ		96W
	DRS-24V100W1NZ		91.2W

DVP	Model Name	Output Voltage	Output Power
	DVP-PS01	24V	24W
	DVP-PS02		48W
	DVP-PS03		120W

Panel Mount Models

PMC, PMF, PMH, PMR, PMT, PMU

PMC	Model Name	Output Voltage	Output Power
	PMC-05V015W1AA	5V	15W
	PMC-05V035W1AA		35W
	PMC-05V050W1AA		50W
	PMC-12V035W1AA	12V	35W
	PMC-12V050W1AA		50W
	PMC-12V060W1NA		60W
	PMC-12V100W1AA	24V	100W
	PMC-12V150W1BA		150W
	PMC-24V035W1AA		35W
	PMC-24V050W1AA	50W	
	PMC-24V075W1AA	75W	
	PMC-24V100W1AA	100W	
	PMC-24V150W1AA	150W	
	PMC-24V150W2AA	150W	
	PMC-24V150W1BA	150W	
	PMC-24V300W1BA	300W	
	PMC-24V600W1BA	600W	
	PMC-DSPV100W1A	24V/5V	100W
PMC-48V150W1BA	48V	150W	

PMF	Model Name	Output Voltage	Output Power
	PMF-4V320WCGB	4.2V	231W
	PMF-5V320WCGB	5V	275W
	PMF-24V200WCGB	24V	201.6W
	PMF-24V240WCGB		240W
	PMF-24V320WCGB		320W

PMH	Model Name	Output Voltage	Output Power
	PMH-12V100WCLS	12V	100W
	PMH-24V50WCAA	24V	50W
	PMH-24V100WCAA		100W
	PMH-24V100WCCA		100W
	PMH-24V100WCLS		100W
	PMH-24V100WCMS		91.2W
	PMH-24V100WCNS		91.2W
	PMH-24V150WCBA		150W
	PMH-24V150WCDA		150W
	PMH-24V150WCLS		150W
	PMH-24V200WCBA		200W

PMR	Model Name	Output Voltage	Output Power
	PMR-4V320WCAA	4.2V	252W
	PMR-4V320WDAA		252W
	PMR-4V320WDGA		252W
	PMR-4V320WDBA		252W
	PMR-4V320WDCA		252W
	PMR-5V320WCAA	5V	300W
	PMR-5V320WDAA		300W
	PMR-5V320WDGA		300W
	PMR-5V320WDBA		300W
	PMR-5V320WDCA		300W

PMT	Model Name	Output Voltage	Output Power
	PMT-4V350W1AM	4.2V	252W
	PMT-5V35W1AA	5V	35W
	PMT-5V50W1AA		50W
	PMT-5V350W1AM		300W
	PMT-12V35W1AA	12V	35W
	PMT-12V50W1AA		50W
	PMT-12V100W1AA		102W
	PMT-12V150W1AA		150W
	PMT-12V350W1AAR		348W
	PMT-15V50W1AA	15V	51W
	PMT-24V35W1AA	24V	35W
	PMT-24V50W1AA		50W
	PMT-24V100W1AA		108W
	PMT-24V150W1AA		156W
	PMT-24V200W1AM		211.2W
	PMT-24V350W1AG	350.4W	
	PMT-36V350W1AR	36V	349.2W
	PMT-48V150W1AA	48V	158.4W
	PMT-48V350W1AR	48V	350W
	PMT-D1V100W1AA	12V/5V	84W/15W
PMT-D2V100W1AA	24V/5V	84W/15W	

PMU	Model Name	Output Voltage	Output Power
	PMU-13V155WCBA	13.8V	151W
	PMU-13V155WCCA	13.8V	151W
	PMU-27V155WCBA	27.6V	151W
	PMU-27V155WCCA		151W

Open Frame Models

PJ, PJB, PJT, PJU

PJ	Model Name	Output Voltage	Output Power
	PJ-5V15WBNA	5V	15W
	PJ-12V15WBNA	12V	15.6W
	PJ-12V30WBNA		30W
	PJ-12V50WBNA		51.6W
	PJ-12V100WBNA	102W	
	PJ-12V150WBNA	150W	
	PJ-24V30WBNA	24V	31.2W
	PJ-24V50WBNA		50.4W
	PJ-24V100WBNA		103.2W
	PJ-24V150WBNA		150W
	PJ-48V50WBNA		48V

PJB	Model Name	Output Voltage	Output Power
	PJB-24V100WBNA	24V	103.2W
	PJB-24V150WBNA		151.2W
	PJB-24V240WBNA		240W

PJU	Model Name	Output Voltage	Output Power
	PJU-27V60WCAA	27V	60W
	PJU-27V60WCBA		60W

PJT	Model Name	Output Voltage	Output Power
	PJT-12V40WBAA	12V	40W
	PJT-12V65WBAA		60W
	PJT-12V100WBAA		100W
	PJT-12V100WBBA	80W ^{A)}	
	PJT-12V100WBBA	100W ^{B)}	
	PJT-15V40WBAA	15V	40W
	PJT-15V65WBAA		63W
	PJT-15V100WBAA		100W
	PJT-15V100WBBA	80W ^{A)}	
	PJT-15V100WBBA	100W ^{B)}	
	PJT-18V40WBAA	18V	40W
	PJT-18V65WBAA		65W
	PJT-18V100WBAA		100W
	PJT-18V100WBBA	80W ^{A)}	
	PJT-18V100WBBA	100W ^{B)}	
	PJT-24V40WBAA	24V	40W
	PJT-24V65WBAA		65W
	PJT-24V100WBAA		100W
	PJT-24V100WBBA	80W ^{A)}	
	PJT-24V100WBBA	100W ^{B)}	
PJT-24V150WBNA	V _i : 27V V _{sb} : 12V	150W	

A) Convection
B) Forced Cooling

State-of-the-art Industrial Network Communication for Smart Industry

Industrial Ethernet Switch

Managed Switches

DVS-328 New

- 24-Port FE + 4-Port GbE Combo SFP, designed for backbone network transmission at control centers
- Complete L2 network management functions: Q-in-Q VLAN, QoS, LACP, IGMP & SNMP v1/v2c/v3
- IPv6 address suitable for larger network and neighbor discovery
- Supports MODBUS TCP and EtherNet/IP protocols that facilitate remote management by SCADA and other industrial devices
- Proprietary ONE RING and ONE CHAIN high-end redundancy technology adopts easy-to-build multiple ring topology, with self-healing recovery time <20 ms to ensure reliable network transmission
- Enhanced network security with IEEE 802.1X, TACACS+, SSH, HTTPS and SNMP v3
- Loopback-Detection to avoid broadcast storms by automatically shutting down the ports over a switching loop
- Cable diagnostic to automatically detect twisted-pair cable quality and periodically report issues
- Auto warning by email, DI, relay, syslog & SNMP trap
- Compatible with various industrial protocols, including EtherNet/IP, Profinet, CC-LINK IE and DNP 3.0
- 85 ~ 264 V_{AC} and 88 ~ 370 V_{DC} wide range redundant power input
- IP40 metal case. -40°C ~ 70°C operating temperature
- Certifications: UL 60950-1, IEC 60950-1, CCC, CE, FCC and RCM



DVS-110

- 7-Port FE + 3-Port GbE Combo SFP, designed for backbone networks
- Complete L2 network management functions: VLAN, QoS, LACP, IGMP & SNMP v1/v2c/v3
- IPv6 address suitable for larger network and neighbor discovery
- Supports MODBUS TCP and EtherNet/IP protocols that facilitate remote management by SCADA and other industrial devices
- Proprietary ONE RING and ONE CHAIN high-end redundancy technology adopts easy-to-build multiple ring topology, with self-healing recovery time <20 ms to ensure reliable network transmission
- Loopback-Detection to avoid broadcast storms by automatically shutting down the ports over a switching loop
- DDM diagnosis function by SFP fiber module
- Auto warning by email, DI, relay, syslog & SNMP trap
- IP40 metal case. -40°C ~ 75°C operating temperature
- Certifications: UL 508, IEC 61131-2, CE, FCC and RCM



DVS-109

- 8-Port FE + 1-Port GbE, Gigabit uplink port elevating transmission bandwidth
- Complete L2 network management functions: VLAN, QoS, LACP, IGMP & SNMP v1/v2c/v3
- IPv6 address suitable for larger network and neighbor discovery
- Supports MODBUS TCP and EtherNet/IP protocols that facilitate remote management by SCADA and other industrial devices
- Proprietary ONE RING and ONE CHAIN high-end redundancy technology adopts easy-to-build multiple ring topology, with self-healing recovery time <20 ms to ensure reliable network transmission
- Loopback-Detection to avoid broadcast storms by automatically shutting down the ports over a switching loop
- Auto warning by email, DI, relay, syslog & SNMP trap
- IP40 metal case. -40°C~75°C operating temperature
- Certifications: UL 508, IEC 61131-2, CE, FCC and RCM



DVS-108

- 6-Port FE + 2-Port GbE Combo SFP, designed for backbone network
- Complete L2 network management functions: VLAN, QoS, LACP, IGMP & SNMP v1/v2c/v3
- IPv6 address suitable for larger network and neighbor discovery
- Supports MODBUS TCP and EtherNet/IP protocols that facilitate remote management by SCADA and other industrial devices
- Proprietary ONE RING and ONE CHAIN high-end redundancy technology adopts easy-to-build multiple ring topology, with self-healing recovery time <20 ms to ensure reliable network transmission
- Loopback-Detection to avoid broadcast storms by automatically shutting down the ports over a switching loop
- DDM diagnosis function by SFP fiber module
- Auto warning by email, DI, relay, syslog & SNMP trap
- IP40 metal case. -40°C~75°C operating temperature
- Certifications: UL 508, IEC 61131-2, CE, FCC and RCM



PoE + Managed Switch

DVS-G512

- 8-Port GbE + 4-Port 100/1000Base-SFP, full Gigabit
- 8 10/100/1000Base-T PoE (PSE) ports, each provides 30 W power supply to meet IEEE 802.3at and IEEE 802.3af standards
- Complete L2 network management functions: VLAN, QoS, LACP, IGMP & SNMP v1/v2c/v3
- IPv6 address suitable for larger network and neighbor discovery
- Advanced PoE management and intelligent powered device(PD) class detection
- IEC 62439-2 MRP media redundancy protocol; IEEE 1588v2 PTP precision time protocol
- DDM diagnosis function by SFP fiber module
- Auto warning by email, relay, syslog & SNMP trap
- IP30 metal case. -40°C ~ 70°C operating temperature
- Certifications: CE, FCC and RCM



Unmanaged Switches

DVS-G005100A

- 5-Port GbE
- Supports IEEE 802.1p based QoS for packet forwarding precedence
- Built-in Broadcast Storm Protection
- Transparent transmission of VLAN tagged packets
- Jumbo packet transmission: up to 9,216 Bytes
- IEEE Green Ethernet for power savings
- IP40 metal case. -10°C~60°C operating temperature
- Certifications: UL 508, IEC 61131-2, CE, FCC and RCM



DVS-005/008/016

- 5/8/16-Port FE; supports long distance transmission via fiber optics
- Supports IEEE 802.1p based QoS for packet forwarding precedence
- Built-in Broadcast Storm Protection
- Transparent transmission of VLAN tagged packets
- Auto warning by relay output for link-down and power failure
- 12~48V_{DC} redundant terminal block power input
- IP40 metal case. -40°C~75°C operating temperature
- Certifications: UL 508, IEC 61131-2, CE, FCC and RCM



PoE+ Unmanaged Switches

DVS-G408W01

- 8-Port GbE, full Gigabit
- 8 10/100/1000Base-T PoE (PSE) ports, each provides 30 W power supply to meet IEEE 802.3at and IEEE 802.3af standards
- Jumbo packet transmission: up to 9,216 Bytes
- Auto warning by relay output for power failure
- IP30 metal case. -40°C~70°C operating temperature
- Certifications: CE, FCC and RCM



DVS-G406W01-2GF

- 4-Port GbE + 2-Port 100/1000Base-SFP, full Gigabit
- 4 10/100/1000Base-T PoE (PSE) ports, each provides 30 W power supply to meet IEEE 802.3at and IEEE 802.3af standards
- Jumbo packet transmission: up to 9,216 Bytes
- Auto warning by relay output for power failure
- IP30 metal case. -40°C~70°C operating temperature
- Certifications: CE, FCC and RCM



SFP Fiber Transceivers

LCP-GbE

- 1-Port GbE, compliant with IEEE 802.3z
- Full duplex operation
- DDM diagnosis function to monitor transmission quality
- Hot-plugging duplex LC connectors for maximum flexibility
- Metal case. -40°C~85°C operating temperature



LCP-1FE

- 1-Port FE, compliant with IEEE 802.3u
- Full duplex operation
- DDM diagnosis function to monitor transmission quality
- Hot-plugging duplex LC connectors for maximum flexibility
- Metal case. -40°C~85°C operating temperature



PoE+ Splitter

DVS-G401

- 1-Port GbE for PoE+ data / power input and 1-Port GbE for data output
- Provides 30W power supply / per port to meet IEEE 802.3at and IEEE 802.3af standards
- Intelligent PoE input overvoltage protection
- Power output up to 27W
- IP30 metal case. -20°C ~ 70°C operating temperature
- Certifications: CE, FCC and RCM



PoE+ Injector

DVS-G402

- 2-Port GbE for PoE+ data / power output and 2-Port GbE for data input
- Provides 30W power supply / per port to meet IEEE 802.3at and IEEE 802.3af standards
- Intelligent PoE output overvoltage protection
- Built-in 12V_{DC} power booster for flexible PoE deployment
- IP30 metal case. -20°C ~ 70°C operating temperature
- Certifications: CE, FCC and RCM



IEEE 802.11 WLAN

DVW-W02W2-E2

- Complete transmission interface: 2-Port GbE + 2-Port RS-232/422/485
- Compliant with IEEE 802.11n wireless technology for up to 450 Mbps data transmission rate
- IEEE 802.11r fast roaming with seamless switch (< 50ms) among APs
- Multiple wireless modes: AP, Client CPE, WDS P-T-P, WDS P-T-MP and Repeater
- Supports serial device servers and MODBUS gateways
- Wireless QoS (IEEE 802.11e, WMM) for video packet transmission precedence
- Enhanced wireless security: 64/128-bit WEP, WPA/WPA2, WPA-PSK/WPA2-PSK (TKIP/AES) and 802.1X Authentication
- Supports MODBUS TCP protocol that facilitates the remote management by SCADA and other industrial devices
- Auto warning by email, DI, relay, Syslog and SNMP trap
- IP40 metal case. -40°C~75°C operating temperature
- Certifications: UL 508, IEC 61131-2, CE, FCC, RCM, BSMI, SRRC and NCC



High-gain Antenna

DVW-ANT

- Supports IEEE 802.11 b/g/n or IEEE 802.11 a/b/g/n
- 2.4 & 5 GHz dual-band omni-directional 5.5 & 8dBi, or 2.4 GHz omni-directional 7dBi
- Powerful magnetic base with 3-meter extension cord and RP-SMA (male) connector
- IP65 waterproof and UV resistant design, suitable for applications under all kinds of weather conditions
- -30°C ~ 60°C operating temperature



Industrial 3G Cloud Router

DX-2100

- 1-Port FE + 1-Port RS-232 + 1-Port RS-485
- UMT/HSPA+: 800/850, 900, AWS1700, 1900, 2100MHz
- GSM/GPRS/EDGE: 850, 900, 1800, 1900MHz
- Supports DIACloud Cloud Management Platform, no public IP address required
- Supports MODBUS TCP and MODBUS ASCII/RTU protocols
- Firewalls: Stateful Packet Inspection (SPI), Denial of Service (DoS) attacks, NAT, Port triggering, Port mapping, IP address filtering, MAC address filtering, URL filtering
- IP30 metal case. -20°C~70°C operating temperature
- Certifications: CE, FCC and UL



Industrial Ethernet Cloud Router

DX-2300

- 4-Port FE LAN + 1-Port FE WAN + 1-Port RS-232 + 1-Port RS-485
- Supports DIACloud Cloud Management Platform, no public IP address required
- Supports MODBUS TCP and MODBUS ASCII/RTU protocols
- Firewalls: Stateful Packet Inspection (SPI), Denial of Service (DoS) attacks, NAT, Port triggering, Port mapping, IP address filtering, MAC address filtering, URL filtering
- IP30 metal case. -20°C~70°C operating temperature
- Certifications: CE, FCC and UL



Industrial 3G/WAN VPN Router

DX-3001

- 4-Port FE LAN + 1-Port FE WAN + 1-Port RS-232 + 1-Port RS-485
- UMTS/HSPA+: 800/850, 900, AWS1700, 1900, 2100MHz)
- Supports IPSec, OpenVPN, PPTP, L2TP and GRE VPN protocols; IPSec with CA certificate supports L2TP over IPSec
- Dual SIM redundancy design: seamless switch among ISP systems for continuous network connection
- Built-in RTC
- Flexible connection method over WAN port, e.g. static IP, DHCP client and more
- Firewalls: Stateful Packet Inspection (SPI), Denial of Service (DoS) attacks, NAT, port triggering, port mapping, IP address filtering, MAC address filtering, URL filtering
- IP30 metal case. -20°C ~ 70°C operating temperature
- Certifications: CE, FCC and UL



High Speed and Stable Industrial Network Solutions

BACnet MS/TP Slave Module DVPSCM52-SL

- BACnet MS/TP slave, standard MODBUS and user-defined RS-422/485 communication protocols
- Compatible with software and DDC of major brands on the market. Remote I/O and converter function available when connected with a PLC with I/O point extension
- Isolated power and communication provide strong noise immunity. Built-in 120 ohm terminal resistor switch and feed-through terminals with spring plugs
- Data transmission settings via software, no complex programming required

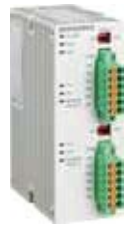

RS-422 / 485 Master Module DVPSCM12-SL

- Standard MODBUS communication and user-defined RS-422/485 communication protocols
- Two sets of independent RS-422/485 communication interfaces
- Isolated power and communication provide strong noise immunity. Built-in 120 ohm terminal resistor switch and feed-through terminals with spring plugs
- Data transmission settings via software, no complex programming required
- Applied as PLC communication ports for program uploading/downloading and monitoring



Ethernet Master Module DVPEN01-SL

- MODBUS TCP protocol
- MODBUS TCP connections:
Client: 32
Server: 16
- Smart data exchange
- RTU mapping
- Simple firewall
- Email alarm



CANopen Master Module DVPCOPM-SL

- CANopen protocol
- Able to connect max. 110 slaves
- Various PDO and high-speed SDO transmission
- Supports NMT slave, Heartbeat, Emergency and more protocols



PROFIBUS DP Slave Module DVPPF02-SL

- PROFIBUS DP slave protocol
- Supports GSD files identification and cyclic data transmission
- Data transmission: up to 100 words IN/OUT data mapping



DeviceNet Master Module DVPDNET-SL

- DeviceNet protocol
- Able to connect max. 63 slaves
- Supports EDS files identification and cyclic data transmission
- Max. network connection distance: 500 m
- RTU mapping



Ethernet Remote I/O Communication Module RTU-EN01

- MODBUS TCP slave protocol
- Able to connect 8 DVP-S Series analog I/O modules
- Able to connect digital I/O (256 points) modules
- RS-485 port supports max. 32 MODBUS slaves
- Smart PLC if-then function
- Smart Monitor function
- Supports webpage setup and on-line monitoring
- Serial Virtual COM available



PROFIBUS DP Remote I/O Communication Module RTU-PD01

- PROFIBUS DP slave protocol
- Auto-detects baudrate, max. baudrate: 12Mbps
- Supports GSD files for identification and cyclic data transmission
- Able to connect 8 DVP-S Series analog I/O modules
- Able to connect digital I/O (256 points)
- RS-485 port supports max. 16 MODBUS slaves



DeviceNet Remote I/O Communication Module RTU-DNET

- DeviceNet protocol
- Supports EDS files for identification and cyclic data transmission
- Able to connect 8 DVP-S Series analog I/O modules
- Able to connect digital I/O (256 points)
- RS-485 port supports max. 8 MODBUS slaves







RS-485 Remote I/O Communication Module RTU-485

- MODBUS protocol
- Able to connect 8 DVP-S Series analog I/O modules
- Able to connect digital I/O (256 points) modules
- Max. baud rate: 115.2Kbps



DVP Series Slave Modules (Right-side)

DVPCP02-H2	DVPPF01-S	DVPPF02-H2	DVPDT01-S	DVPDT02-H2
				
Description				
CANopen slave module Supports DVP-EH2/3 Series	PROFIBUS slave module Supports DVP-S Series	PROFIBUS slave module Supports DVP-EH2/3 Series	DeviceNet slave module Supports DVP-S Series	DeviceNet slave module Supports DVP-EH2/3 Series

Impedance to Noise with a Range of Fieldbus Converters



Applications

Intelligent transportation systems, water treatment, building automation, factory automation, monitoring and control systems

USB Converters

	<p>UC-PRG020-12A USB » RS-232</p>	<ul style="list-style-type: none"> • Delta programming cables • RS-232 port provides Mini-DIN and DB9 connectors • A portable hot-plugging USB device, no power supply required
	<p>IFD6500 USB » RS-485</p>	<ul style="list-style-type: none"> • Lightweight design for easy portability • Auto-detection of data flow direction • A portable USB device • Supports Win XP, Win7 32/64-bit
	<p>IFD6503 USB » CAN</p>	<ul style="list-style-type: none"> • Extracts CAN messages (incl. standard and extended frames), decodes and displays following DeviceNet and CANopen protocols • Filters by set conditions • Sends CAN messages (1 message by manual mode, 8 messages by auto mode) • Max. 1 Mbps • A portable USB device
	<p>IFD6530 USB » RS-485</p>	<ul style="list-style-type: none"> • Lightweight design for easy portability • Auto-detection of data flow direction • Supports KPC-CC01 keypad in conducting parameters and page editing • Supports Win XP, Win7 32/64-bit • A portable USB device

MODBUS Serial Converters

	IFD8500A RS-232 « » RS-485	<ul style="list-style-type: none"> • RS-232 to RS-422 / 485 isolated converter • Auto transmission speed adjustment
	IFD8510A RS-422/485	<ul style="list-style-type: none"> • RS-422 / 485 isolated regenerator • RS-422 / 485 transmission distance extended to 1.2 km • Able to connect to 32 RS-485 devices • Auto transmission speed adjustment and data flow direction control
	IFD8520 RS-232 « » RS-485	<ul style="list-style-type: none"> • RS-232 to RS-422/485 addressable isolated converter • Connects RS-232 to RS-422/485 by setting up MODBUS address

Industrial Network Converters

	IFD9502 DeviceNet » MODBUS	<ul style="list-style-type: none"> • DeviceNet protocol • Able to connect Delta industrial automation products • Isolation in RS-485 channel (incl. power supply) • Full compatibility test passed
	IFD9503 CANopen » MODBUS	<ul style="list-style-type: none"> • CANopen protocol • Able to connect all Delta industrial automation products • Isolation in RS-485 channel (incl. power supply) • Full compatibility test passed
	IFD9506 MODBUS TCP « » MODBUS	<ul style="list-style-type: none"> • Isolation in RS-485 channel (incl. power supply) • MODBUS TCP protocol • Smart Monitor function • Supports webpage setup and on-line monitoring • Serial Virtual COM available • Alarm notification through email
	IFD9507 EtherNet/IP « » MODBUS	<ul style="list-style-type: none"> • Isolation in RS-485 channel (incl. power supply) • EtherNet/IP and MODBUS TCP protocols • Smart Monitor function • Supports webpage setup and on-line monitoring • Serial Virtual COM available • Alarm notification through email

Industrial Automation Solutions

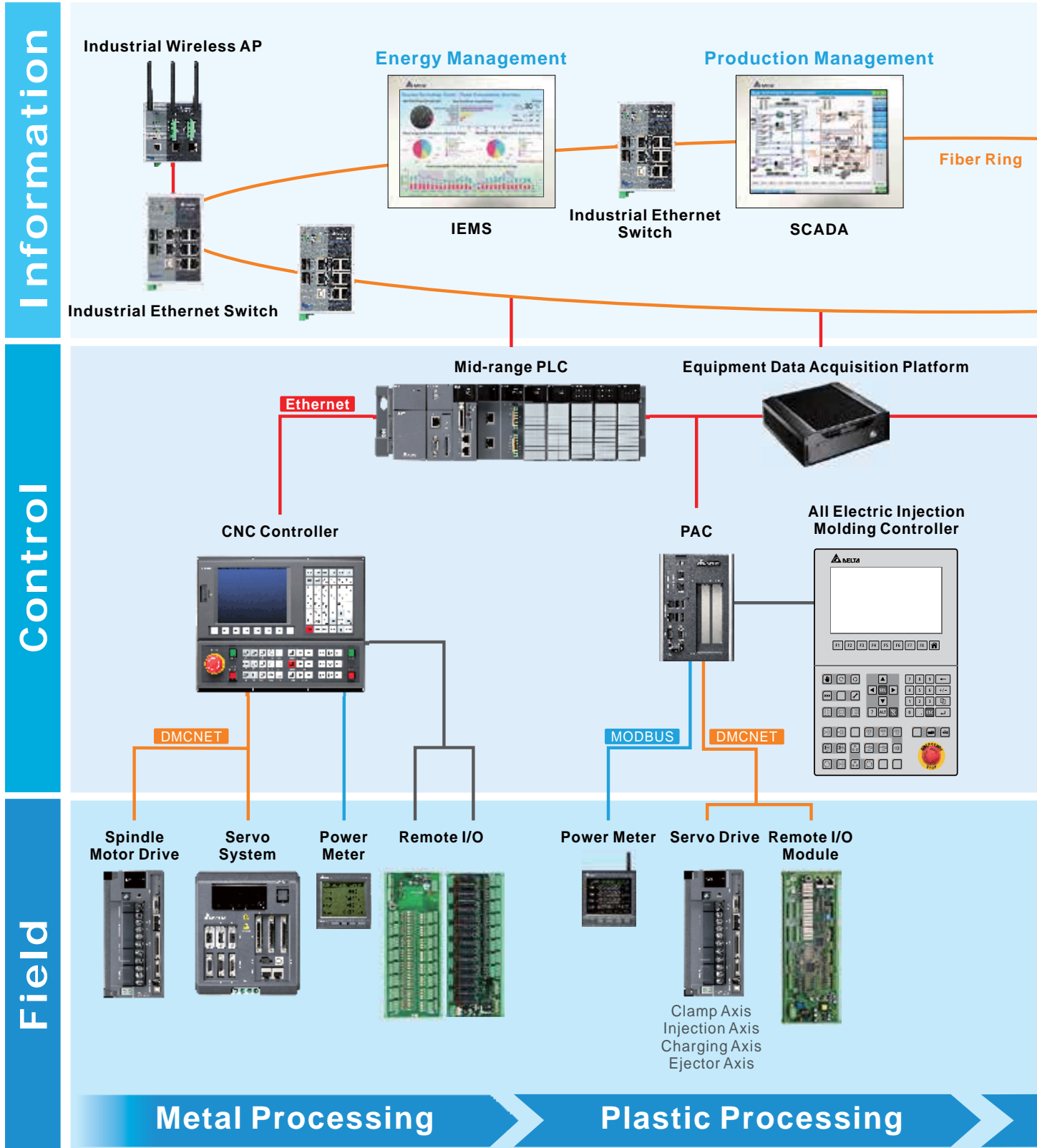

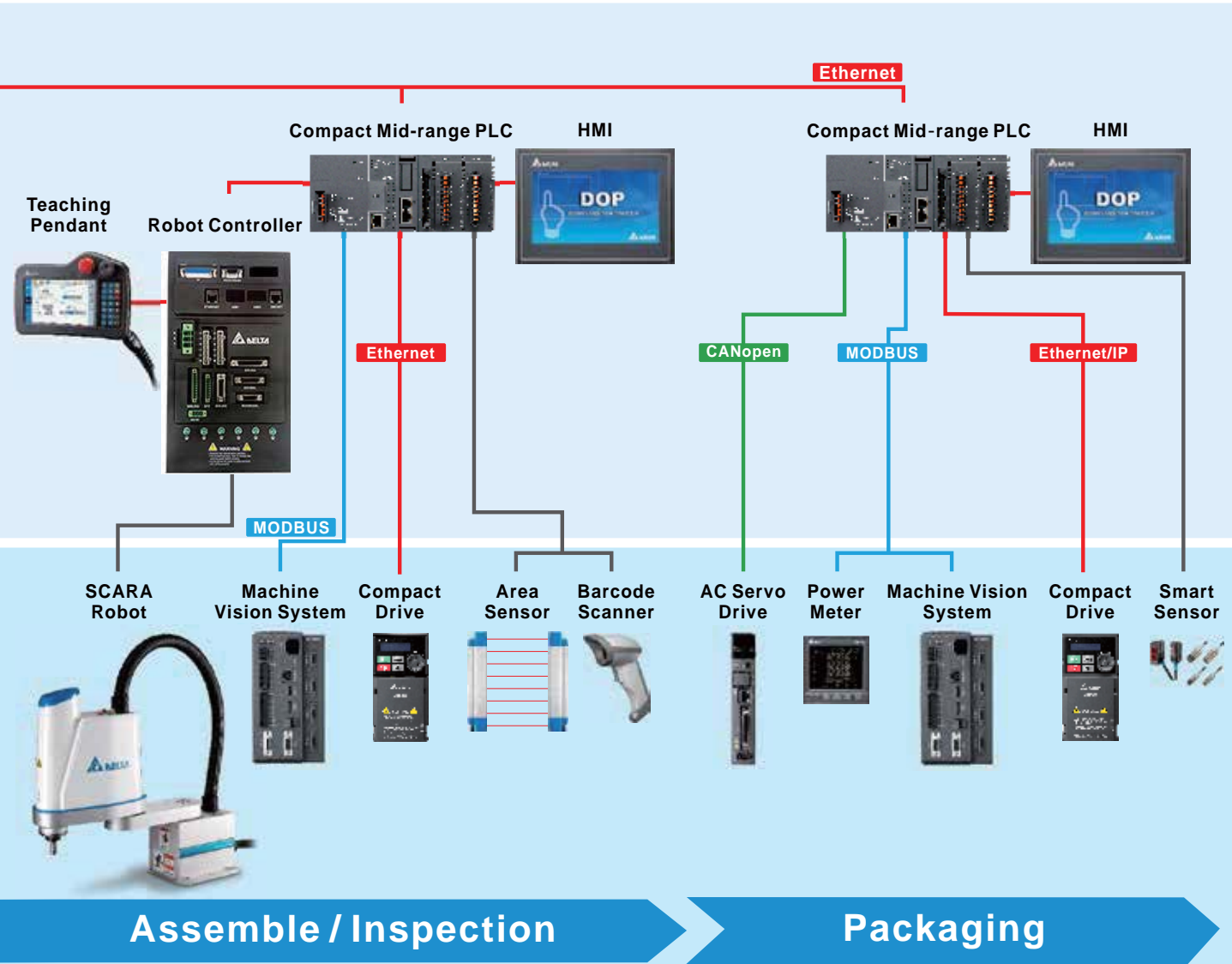
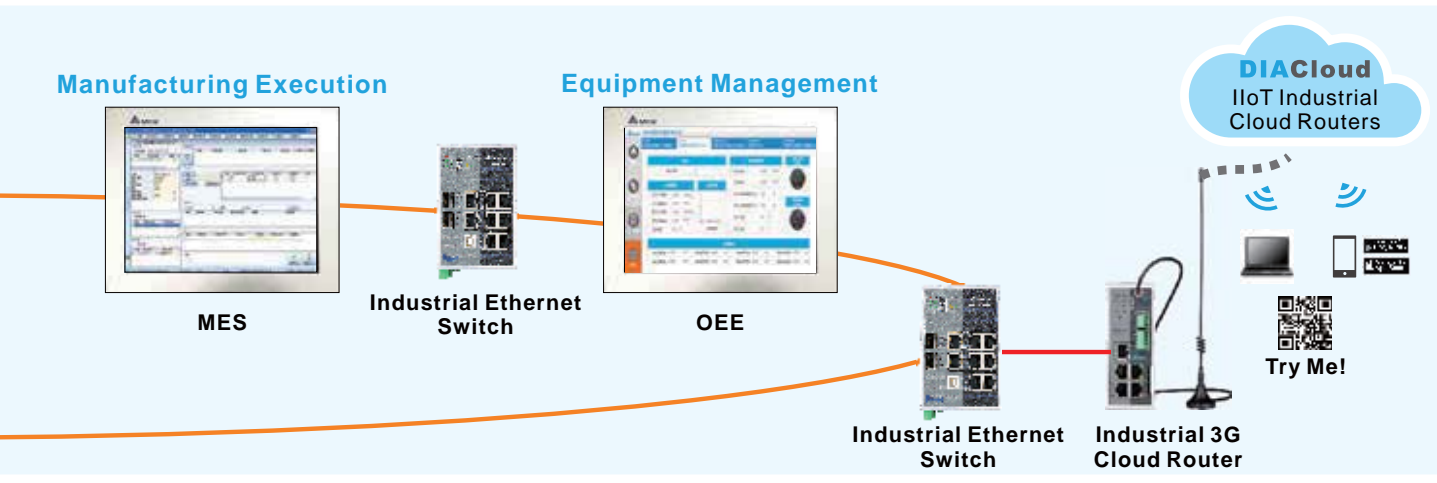

Industrial PC

DIAV

Stable and High-performance Integration

- IPC with 15" and 19" TFT LCD touch screen
- Wide operating temperature range, suitable for applications in harsh industrial environments
- Fanless and low power Intel Core i3 / i5 processor with high efficiency and excellent performance
- One-click start up click (Power-on)
- Embedded Windows 7 operating system with 256G / 512G SSD
- Full compatibility with SCADA and IEMS software platform



DIAVH-IPC DIAVH-PPC15 DIAVH-PPC19

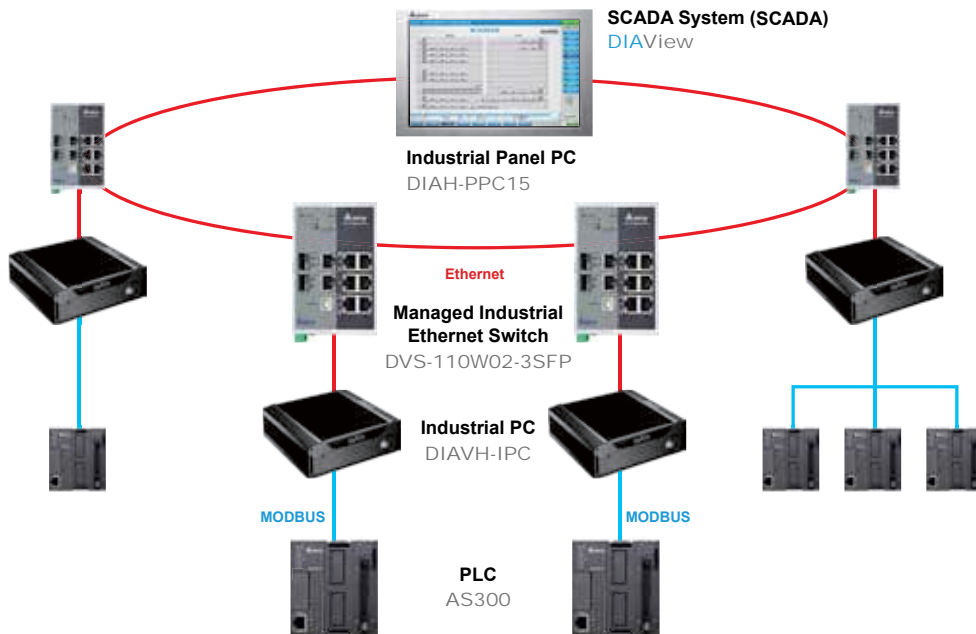

Facility Management Control System	Equipment Management System	Production Process Control System	Production Quality Management System
------------------------------------	-----------------------------	-----------------------------------	--------------------------------------

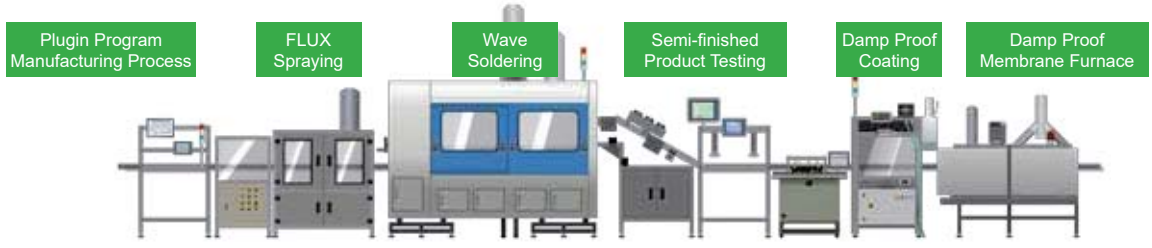

Applications

Equipment for electronics manufacturing, machinery equipment, HVAC, water treatment, facility management and monitoring control

Factory Digitalization

- Factory data acquisition, process control and management
- Distributed system calculation for data and information storage and analytics

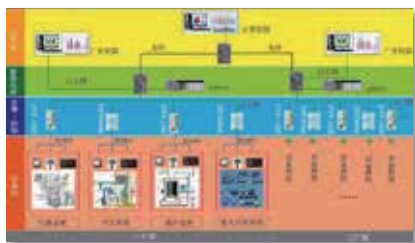

Factory Digitalization



Factory Equipment Monitoring

Logistic Application: Transportation and Stereoscopic Warehouse

- The database saves the location of materials; barcode scanning enhances load/unload and sorting efficiency to save space and labor costs



Warehousing System

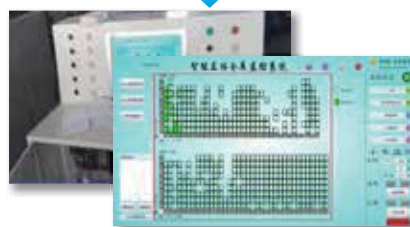

Warehouse Monitoring

Inspection & Monitoring of Electronic Equipment

- DIAView interacts with the programming processes of PLCs and inspection equipment, realizing powerful group control
- With DIAView, the system can record daily production identify qualified and unqualified products, and provide inquiry functions



Electronic Inspection Equipment



Inspection and Monitoring of Electronic Equipment

Equipment Monitoring System

- Achieves real-time remote monitoring of machine operating status
- Allows device suppliers to remotely lock/unlock devices for flexible management



Total Configuration of Equipment Monitoring

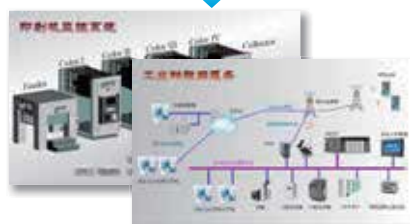

Equipment Remote Monitoring

Equipment IoT Platform New

DIALink

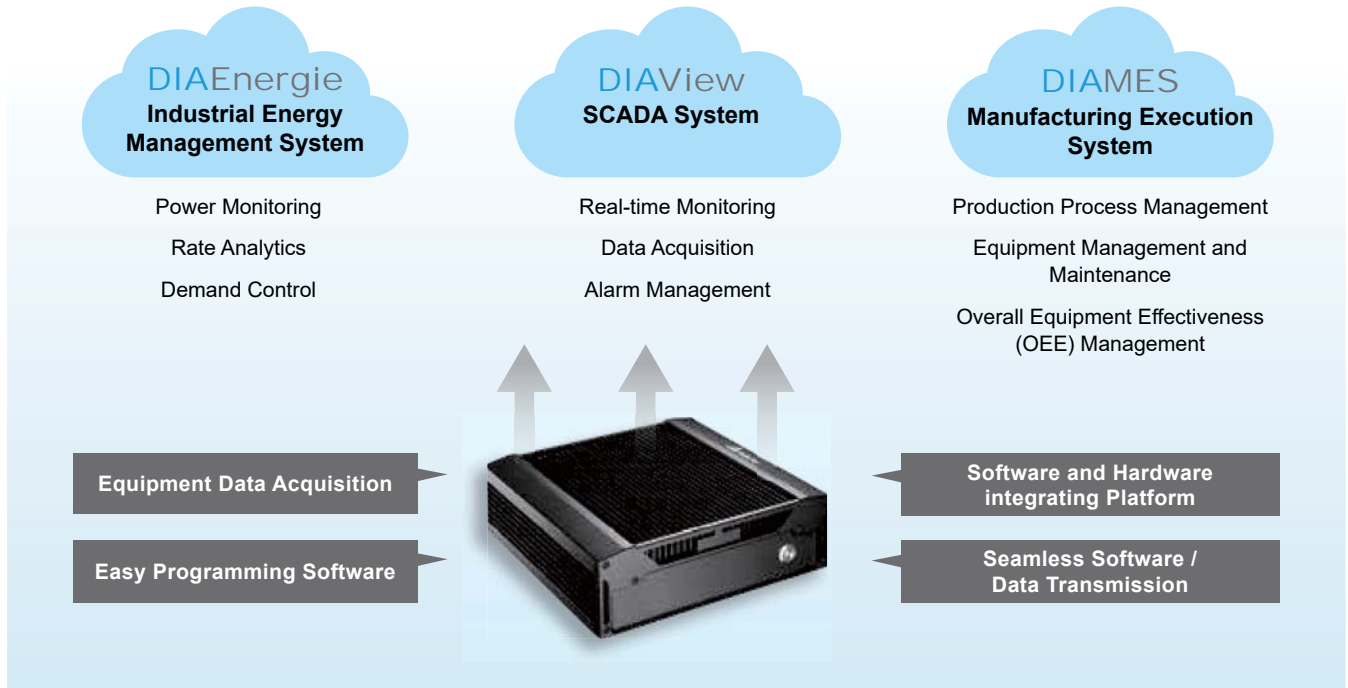

Equipment Monitoring and Data Acquisition

Features

- Supports all major CNC and PLC drivers
- Equipment monitoring and data acquisition
- Data temporary storage function

Benefits

- Equipment data digitalization and management
- Customized (user-defined) real-time information visualization
- Machine abnormality and idle time monitoring
- Enhanced efficiency by improving control of Overall Equipment Effectiveness (OEE)

Applications

- Equipment data real-time collection
- Equipment analysis and management
- Remote monitoring and control

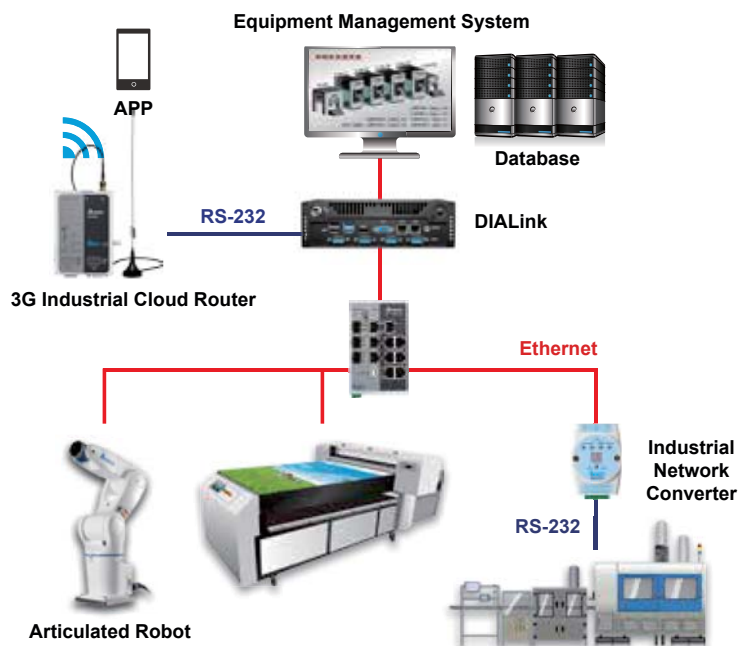

Rapid, Seamless and Secure Data Transfer

- Supports OPC Server
- Supports MODBUS slaves, XML, JSON data formats
- Open Web API

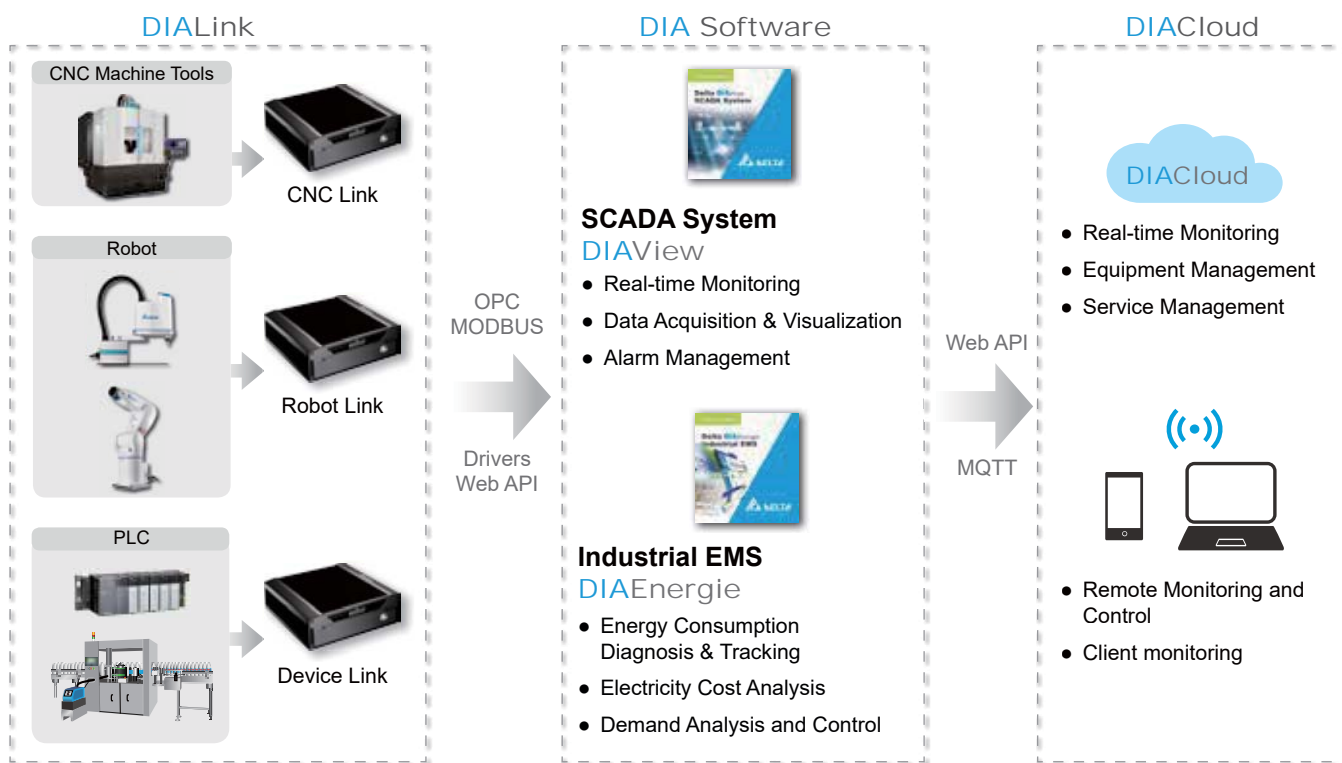

DIALink Models - PLC/CNC/Robot

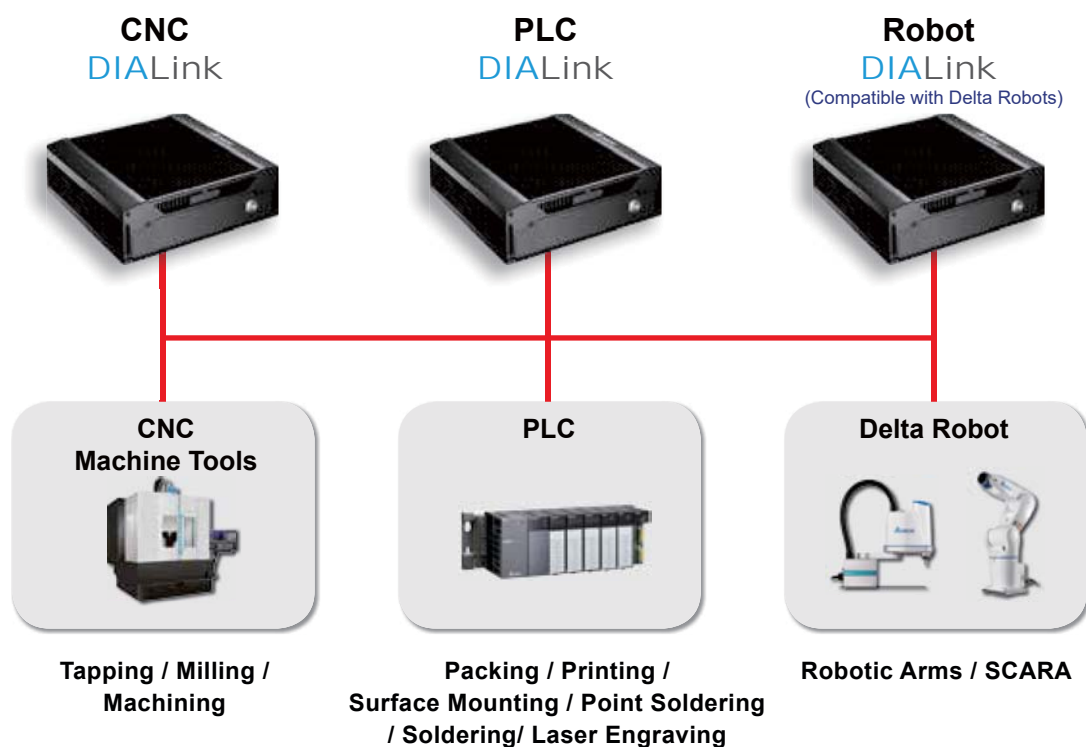

SCADA System

DIAView

Evolution of Factory Visualization and Analysis Management



- Seamless integration with Delta's PLC products and I/O modules, supporting various industrial communication protocols and equipment drivers
- WPF technology for intuitive and vivid displays, and easy-to-navigate interfaces
- Flexible variables dictionary and batch editing parameters
- A variety of data visualization tools: reports, alarms, charts and trend graphs
- Diversified real-time and historical data analysis tools
- Strong and efficient alarm management
- Easy-to-learn VBScript language
- Reliable user authority management for different user levels

System Structure and Applications

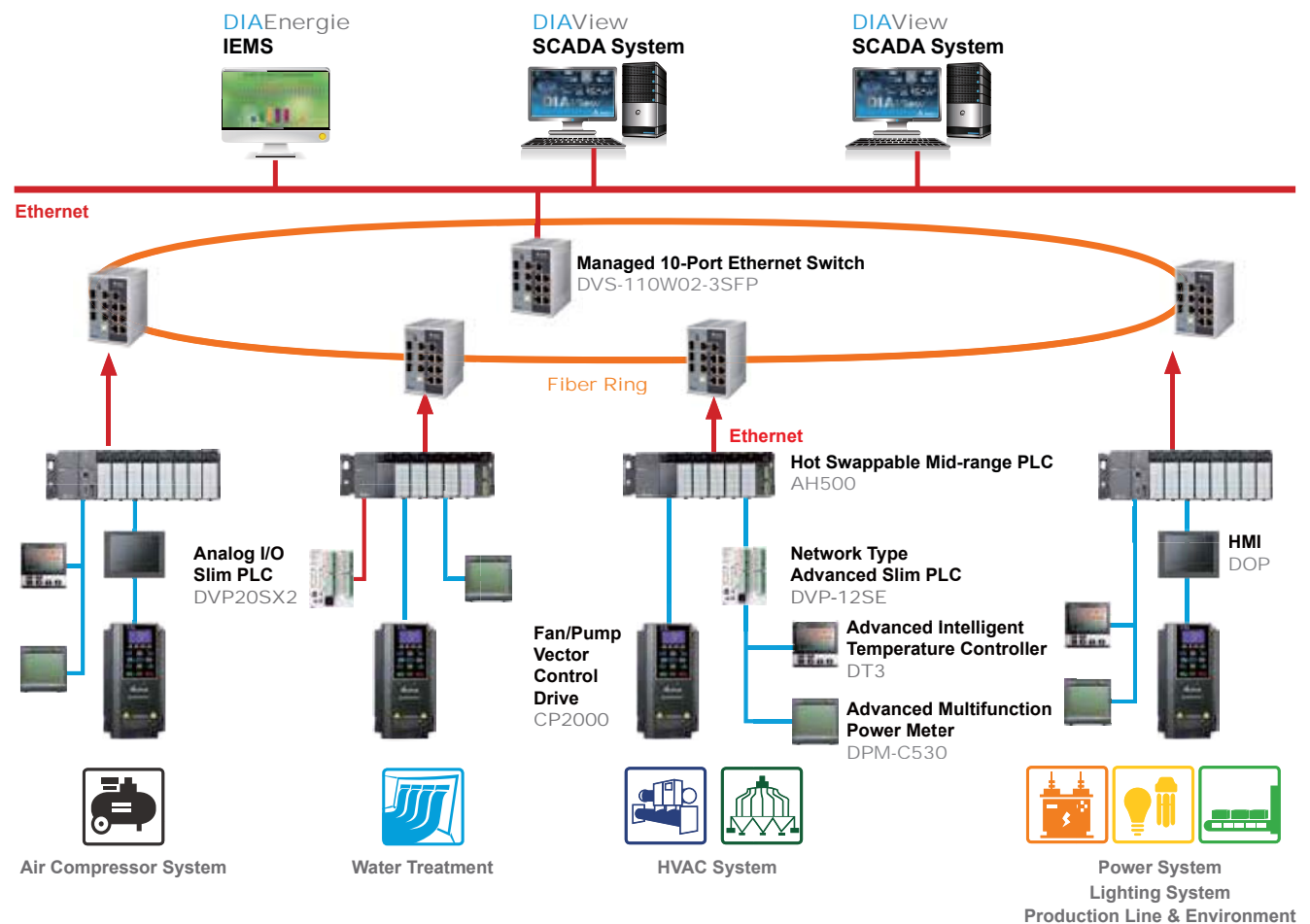

Applications

HVAC, water treatment, central heating, electronics manufacturing

Industrial Energy Management System

DIAEnergie

Innovative Solution for Smart Energy Saving

- Visualization and remote monitoring of critical power consumption
- Data analysis by areas and user levels
- Monitoring and analysis to meet energy performance strategy
- Instant record and alarm delivery for abnormal machine actions
- Power consumption measurement and analysis to achieve more efficient electricity usage and electricity cost savings
- Demand management and forecast to avoid over-limit demand penalties
- Customized user-defined reporting tools for displaying a variety of data analysis



System Structure and Applications

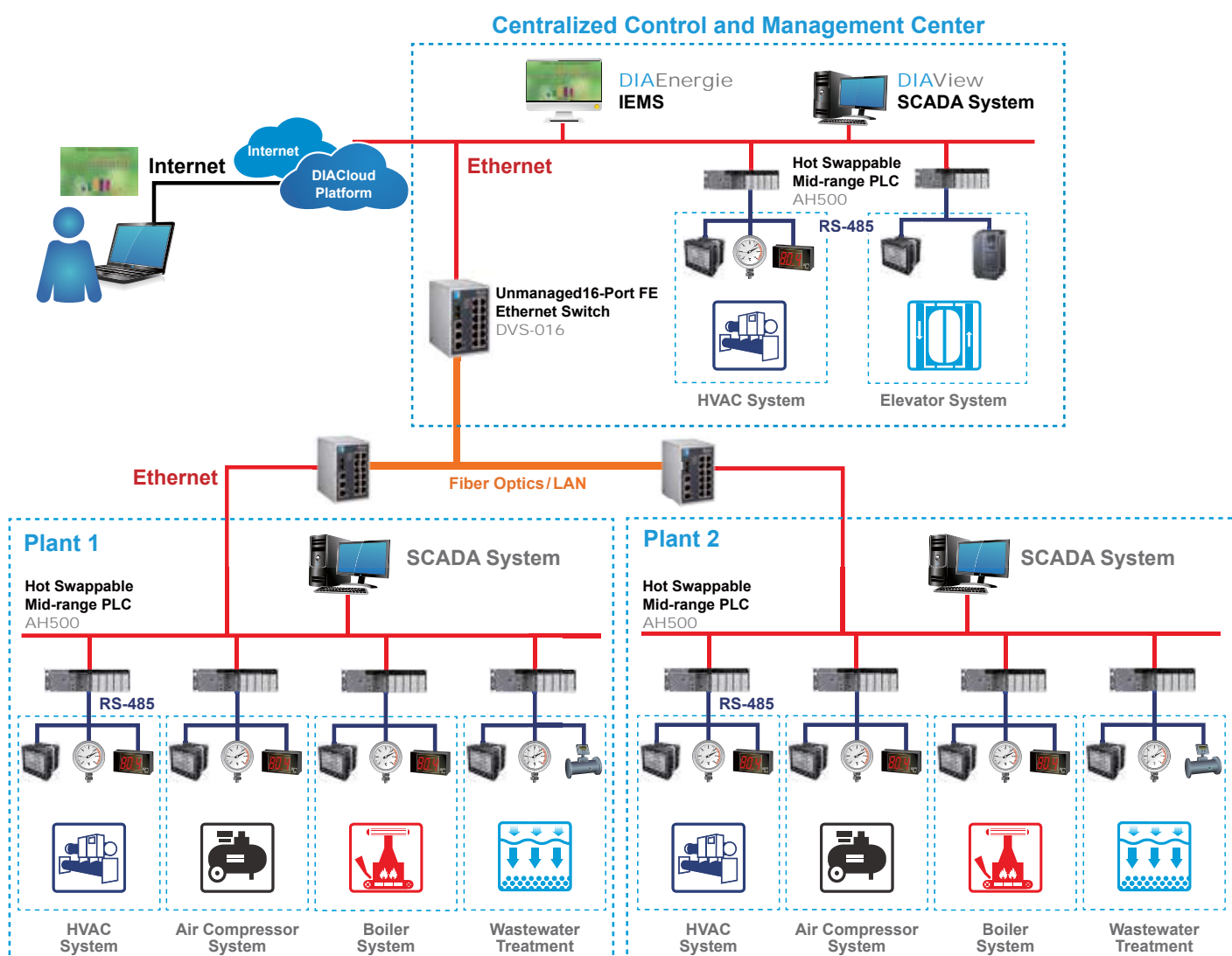

Delta Articulated Robot New

DRV70L / DRV90L

New Emerging Intelligent Industrial Automation Trend

- High precision, high speed
- Built-in 3 solenoid valves for quick integration and application
- Hollow design of the robot wrist (the 6th axis) for wiring and tool placement
- Slim and compact body design
 - Overall width: Max. 235 mm
 - Footprint: 190 x 190 mm
- High integration and efficiency
 - Matches with key devices for production automation
 - Quick integration with peripheral components for workstation applications



DRV70L DRV90L

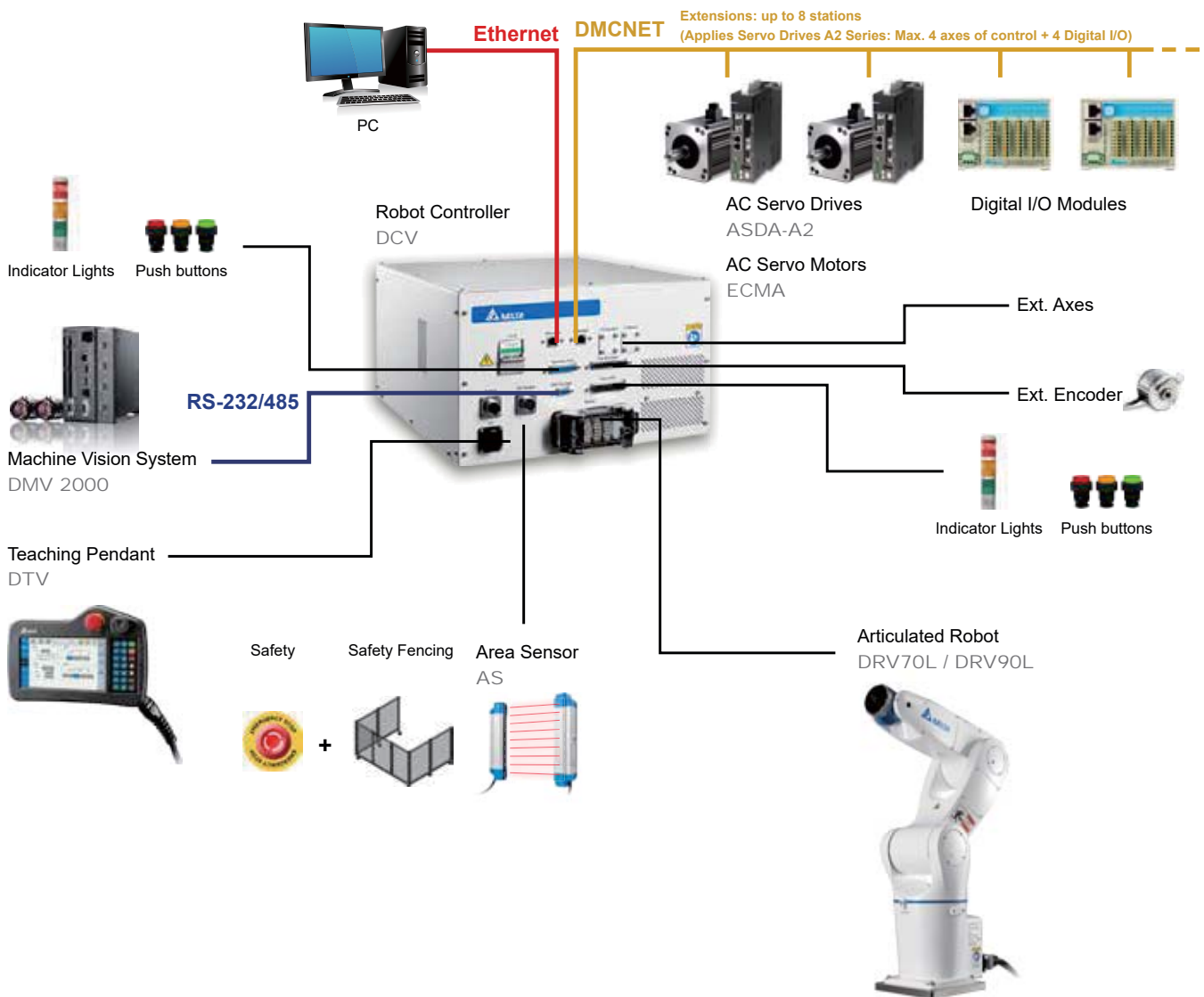

Product Specifications

Model	DRV70L		DRV90L
Number of axes	6		
Max. Working Range	710 mm		900 mm
Max. Payload	7kg		
Motion Range (Max. Speed)	J1	±170° (450 sec)	±170° (370 sec)
	J2	+133° / -105° (340 sec)	+135° / -105° (260 sec)
	J3	+65° / -205° (510 sec)	+65° / -205° (410 sec)
	J4	±190° (550 sec)	
	J5	±120° (550 sec)	
	J6	±360° (820 sec)	
Repeatability	±0.02 mm		±0.03 mm
Standard Cycle Time ^{*1}	0.32 sec		0.35 sec
Installations	Desk mounted, Wall mounted, Ceiling mounted		
Installed Wire for Customer Use	One 12Pos. connector for sensor connections and two Ø6 pneumatic tubings (one is for three built-in solenoids, the other is for extension purpose)		
IP rating ^{*2}	IP40 (Standard) / IP65 (Optional)		
Environment	Temperature	0°C ~ 40°C	
	Humidity	20 ~ 85%RH	
	Vibration	0.5G	
Weight	37kg		39kg
Controller Series	Robot Controller DCV Series		

- Hollow design of the robot wrist



No Hollow Design

Tangled wire / cords lead to equipment interference



Hollow Design

Enhance reliability of extension wire / cords

- DROE (Delta Robot Environment Operation) Software

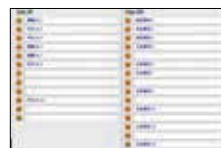

*1. When carrying a payload of 1Kg and reciprocating 25mm in vertical and 300mm in horizontal directions under an operating temperature of 25°C and within a humidity of 45% ~ 65% RH (non-condensing)

*2. Please contact regional sales when environment situations are not within the above specifications

DRV70L Unit: mm

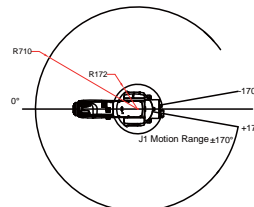
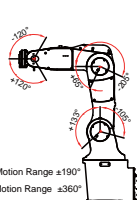
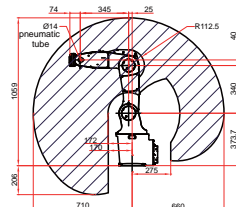

DRV90L

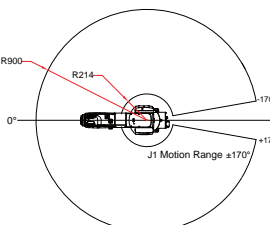
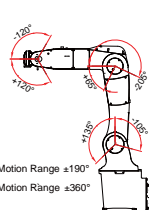
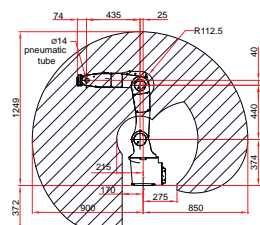

DRV70L / 90L

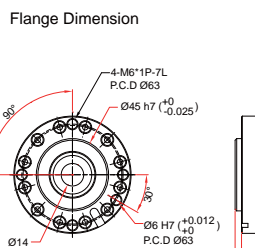
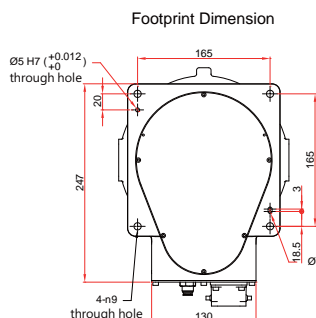

We reserve the right to change the information in this catalogue without prior notice.

SCARA Robot

DRS40L / DRS50L ^{New} / DRS60L / DRS60H ^{New} / DRS70L ^{New}

New Emerging Intelligent Industrial Automation Trend



DRS40L

DRS60L



Teaching Pendant

DTS



Robot Controller

DCS

Product Specifications						
Product Series	DRS40L	DRS50L ^{New}	DRS60L	DRS60H ^{New} (To be launched)	DRS70L ^{New}	
Installations	Desk mounted	Desk mounted	Desk mounted	Ceiling mounted	Desk mounted	
Arm Length (X+Y)	400 mm	500 mm	600 mm	600 mm	700 mm	
Max. Payload	3 kg	6 kg	6 kg	6 kg	6 kg	
Motion Range	J1	±130°	±133°	±130°	±133°	
	J2	±146.6°	±153°	±153°	±153°	
	J3	150 mm	200 mm	200 mm	200 mm	200 mm
	J4	±360°	±360°	±360°	±360°	±360°
Standard Cycle Time (1kg)	0.42 sec	0.39 sec	0.39 sec	0.39 sec	0.40 sec	
Repeatability	X-Y	±0.01 mm	±0.015 mm	±0.015 mm	±0.015 mm	±0.015 mm
	Z	±0.01 mm	±0.01 mm	±0.01 mm	±0.01 mm	±0.01 mm
	RZ	±0.01 °	±0.01 °	±0.01 °	±0.01 °	±0.01 °

SCARA Robot Applications

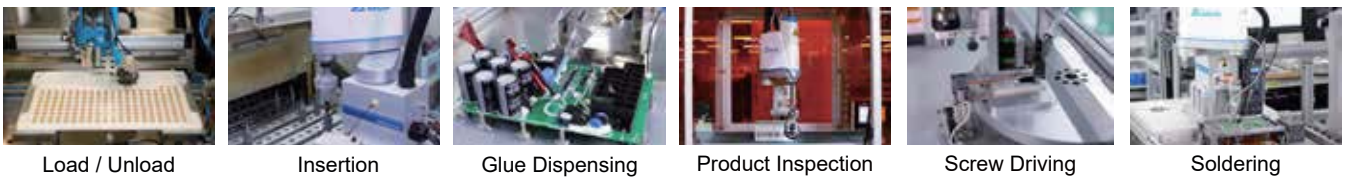

Load / Unload

Insertion

Glue Dispensing

Product Inspection

Screw Driving

Soldering

- High repeatability, high precision, excellent linearity and verticality

Standard cycle time:

Time required for robot to move back and forth with 1kg payload between two points 300mm apart and at a height of 25mm

Product Series	Payload	Standard Cycle Time
DRS40L	1 kg	0.42 sec
DRS50L	1 kg	0.39 sec
DRS60L	1 kg	0.39 sec
DRS60H	1 kg	0.39 sec
DRS70L	1 kg	0.40 sec

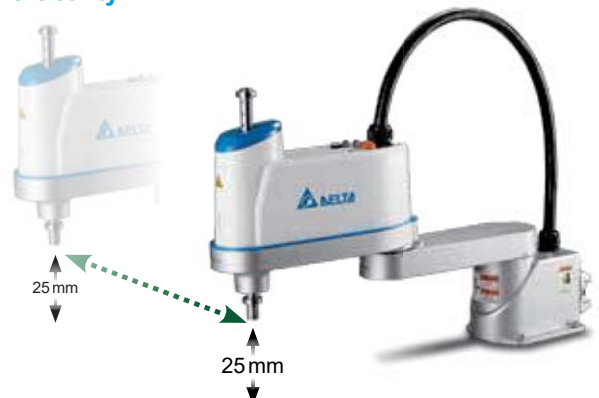

• Sensor-less Compliance Control Function

- Compensates for the deviation between workpieces and insertion holes
- Fast and precise smooth insertion
- Improves assembly and production performance

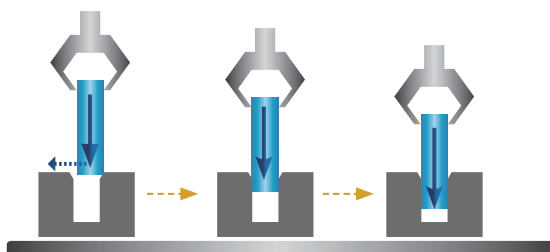

- Insertion performance may differ depending on workpiece hardness.

• Offline Simulation Function

- Robotic integration software with simulation modules
- Shortens development time
- Pre-evaluation, saves cost
- Fast programming
- Simple and easy-to-operate

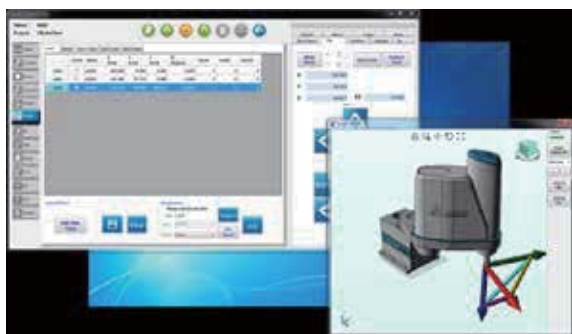

• Real-Time Information Monitoring and Gathering

- Robot machine data monitoring and analysis
- Oversees real-time machine operation data
- On-site production information acquisition



Equipment Data Acquisition Platform
DIALink



Overall Equipment Effectiveness Platform
DIAOEE

• Intuitive Teaching Methods with Versatile Control Approaches



Positions are directly taught and controlled by hand, and recorded by SCARA.



• Arch Motion Control

- Route optimization
- Saves motion time
- Quick and easy setting
- Prevents clash when near the top or edge of robot route planning
- Optimizes arch route setting, fast operational speed

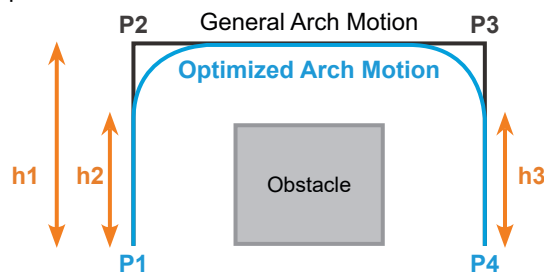

• Optimizes Operational Efficiency

- Safe operation, improves operational stability
- Excellent dynamic display for operational efficiency and intelligent control
- Smart temperature control, real-time control of working environment

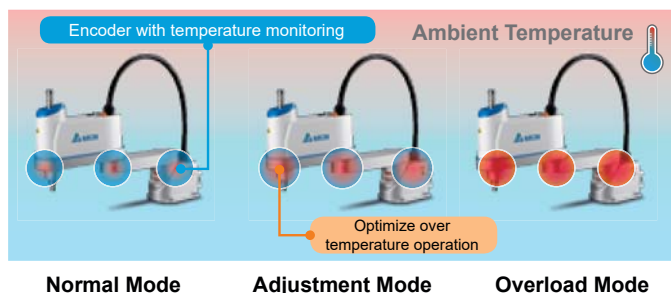

Applications

Industries: Electrical/electronics, consumer electronics, rubber and plastic and metal fabrication, food and beverages

Techniques: Palletizing, assembly, packaging, insertion, glue dispensing, soldering, labeling and inspection, screw driving, load and unload, pick-and-place

Global Operations

ASIA (Taiwan)



Taoyuan Technology Center (Green Building)



Taoyuan Plant 1



Taoyuan Plant (Diamond-rated Green Building)

ASIA (China)



Wujiang Plant 3



Delta Electronics

USA

- A** Portland
- B** Sacramento
- C** Fremont
- D** City of Industry
- E** Chicago
- F** St Louis
- G** Houston
- H** Dallas
- I** Boston
- J** Knoxville
- K** Orlando

Canada

- Kitchner
- Montreal
- Toronto
- Raleigh

Mexico

- A** Mexico City
- B** Monterey
- C** Guadalajara

Colombia

- Venezuela
- Ecuador

Brasil

- Peru
- Bolivia
- Paraguay
- Chile
- Sao Paulo

Argentina

Netherlands

- Amsterdam
- Eindhoven

France

- Paris

Spain

- Barcelona
- Madrid

Italy

- Milan
- Rome

Europe

- A** Finland
- B** Estonia
- C** Sweden
- D** Denmark
- E** Netherlands
- F** Germany
- G** Poland
- H** Czech
- I** Hungary
- J** Slovenia
- K** Croatia
- L** Serbia
- M** Austria
- N** Slovakia

Brasil

- A** Minas Gerais
- B** Pernambuco
- C** Rio de Janeiro
- D** São Paulo
- E** Paraná
- F** Santa Catarina
- G** Rio Grande do Sul

Germany

- Sust

ASIA (Japan)



Tokyo Office

ASIA (India)



Rudrapur Plant
(Green Building)

EUROPE



Amsterdam, Netherlands

AMERICA



Research Triangle Park

▲ Factories 4 ■ Branch Offices 122 ● R&D Centers 5 ▣ Distributors 733





Smarter. Greener. Together.

Industrial Automation Headquarters

Delta Electronics, Inc.

Taoyuan Technology Center
No.18, Xinglong Rd., Taoyuan District,
Taoyuan City 33068, Taiwan
TEL: 886-3-362-6301 / FAX: 886-3-371-6301

Asia

Delta Electronics (Shanghai) Co., Ltd.

No.182 Minyu Rd., Pudong Shanghai, P.R.C.
Post code : 201209
TEL: 86-21-6872-3988 / FAX: 86-21-6872-3996
Customer Service: 400-820-9595

Delta Electronics (Japan), Inc.

Tokyo Office
Industrial Automation Sales Department
2-1-14 Shibadaimon, Minato-ku
Tokyo, Japan 105-0012
TEL: 81-3-5733-1155 / FAX: 81-3-5733-1255

Delta Electronics (Korea), Inc.

Seoul Office
1511, 219, Gasan Digital 1-Ro., Geumcheon-gu,
Seoul, 08501 South Korea
TEL: 82-2-515-5305 / FAX: 82-2-515-5302

Delta Energy Systems (Singapore) Pte Ltd.

4 Kaki Bukit Avenue 1, #05-04, Singapore 417939
TEL: 65-6747-5155 / FAX: 65-6744-9228

Delta Electronics (India) Pvt. Ltd.

Plot No.43, Sector 35, HSIIDC Gurgaon,
PIN 122001, Haryana, India
TEL: 91-124-4874900 / FAX : 91-124-4874945

Delta Electronics (Thailand) PCL.

909 Soi 9, Moo 4, Bangpoo Industrial Estate (E.P.Z),
Pattana 1 Rd., T.Phraksa, A.Muang,
Samutprakarn 10280, Thailand
TEL: 66-2709-2800 / FAX : 662-709-2827

Delta Energy Systems (Australia) Pty Ltd.

Unit 20-21/45 Normanby Rd., Notting Hill Vic 3168, Australia
TEL: 61-3-9543-3720

Americas

Delta Electronics (Americas) Ltd.

Raleigh Office
P.O. Box 12173, 5101 Davis Drive,
Research Triangle Park, NC 27709, U.S.A.
TEL: 1-919-767-3813 / FAX: 1-919-767-3969

Delta Greentech (Brasil) S/A

São Paulo Office
Rua Itapeva, 26 – 3º Andar - Bela Vista
CEP: 01332-000 – São Paulo – SP - Brasil
TEL: 55-11-3530-8642 / 55-11-3530-8640

Delta Electronics International Mexico S.A. de C.V.

Mexico Office
Vía Dr. Gustavo Baz No. 2160, Colonia La Loma,
54060 Tlalnepanitla Estado de Mexico
TEL: 52-55-2628-3015 #3050/3052

EMEA

Headquarter: Delta Electronics (Netherlands) B.V.

Sales: Sales.IA.EMEA@deltaww.com
Marketing: Marketing.IA.EMEA@deltaww.com
Technical Support: iatechnicalsupport@deltaww.com
Customer Support: Customer-Support@deltaww.com
Service: Service.IA.emea@deltaww.com
TEL: +31(0)40 800 3800

BENELUX: Delta Electronics (Netherlands) B.V.

De Witbogt 20, 5652 AG Eindhoven, The Netherlands
Mail: Sales.IA.Benelux@deltaww.com
TEL: +31(0)40 800 3800

DACH: Delta Electronics (Netherlands) B.V.

Coesterweg 45, D-59494 Soest, Germany
Mail: Sales.IA.DACH@deltaww.com
TEL: +49(0)2921 987 0

France: Delta Electronics (France) S.A.

ZI du bois Challand 2, 15 rue des Pyrénées,
Lisses, 91090 Evry Cedex, France
Mail: Sales.IA.FR@deltaww.com
TEL: +33(0)1 69 77 82 60

Iberia: Delta Electronics Solutions (Spain) S.L.U

Ctra. De Villaverde a Vallecas, 265 1º Dcha Ed.
Hormigueras – P.I. de Vallecas 28031 Madrid
TEL: +34(0)91 223 74 20

C/Llull, 321-329 (Edifici CINC) | 22@Barcelona, 08019 Barcelona

Mail: Sales.IA.Iberia@deltaww.com
TEL: +34 93 303 00 60

Italy: Delta Electronics (Italy) S.r.l.

Ufficio di Milano Via Senigallia 18/2 20161 Milano (MI)
Piazza Grazioli 18 00186 Roma Italy
Mail: Sales.IA.Italy@deltaww.com
TEL: +39 02 64672538

Russia: Delta Energy System LLC

Vereyskaya Plaza II, office 112 Vereyskaya str.
17 121357 Moscow Russia
Mail: Sales.IA.RU@deltaww.com
TEL: +7 495 644 3240

Turkey: Delta Greentech Elektronik San. Ltd. Sti. (Turkey)

Şerifali Mah. Hendem Cad. Kule Sok. No:16-A
34775 Ümraniye – İstanbul
Mail: Sales.IA.Turkey@deltaww.com
TEL: + 90 216 499 9910

GCC: Delta Energy Systems AG (Dubai BR)

P.O. Box 185668, Gate 7, 3rd Floor, Hamarain Centre
Dubai, United Arab Emirates
Mail: Sales.IA.MEA@deltaww.com
TEL: +971(0)4 2690148

Egypt + North Africa: Delta Electronics

511 Cairo Bussiness Plaza, North 90 street,
New Cairo, Cairo, Egypt
Mail: Sales.IA.MEA@deltaww.com