

AS36 ASC36

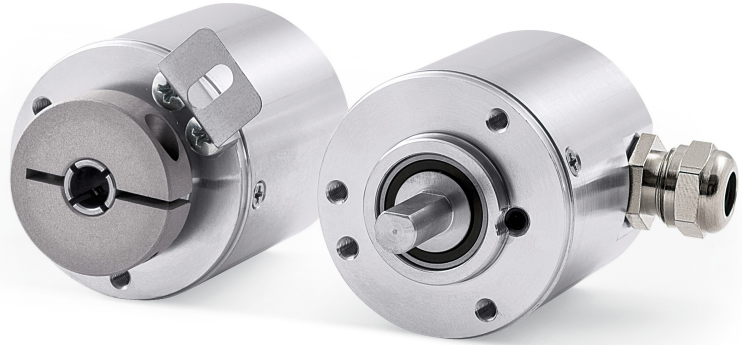

- Miniature absolute singleturn encoder
- Robust construction for industrial applications
- IP67 protection and extended temperature range
- Resolution up to 20 bits (1,048,576 cpr)
- SSI and BiSS C-mode interfaces

Suitable for the following models:

- ASx36xx/BG1-...
- ASx36xx/BG2-...
- ASx36xx/GG1-...
- ASx36xx/GG2-...
- ASx36xx/SC1-...
- ASx36xx/SC2-...

General contents

Preliminary information	7
1 - Safety summary	8
2 - Identification	10
3 - Mounting instructions	11
4 - Electrical connections	14
5 - SSI interface	17
6 - BiSS C-mode interface	21
7 - Default parameters list	31

This publication was produced by Lika Electronic s.r.l. 2017. All rights reserved. Tutti i diritti riservati. Alle Rechte vorbehalten. Todos los derechos reservados. Tous droits réservés.

This document and information contained herein are the property of Lika Electronic s.r.l. and shall not be reproduced in whole or in part without prior written approval of Lika Electronic s.r.l. Translation, reproduction and total or partial modification (photostat copies, film and microfilm included and any other means) are forbidden without written authorisation of Lika Electronic s.r.l.

The information herein is subject to change without notice and should not be construed as a commitment by Lika Electronic s.r.l. Lika Electronic s.r.l. reserves the right to make all modifications at any moments and without forewarning.

This manual is periodically reviewed and revised. As required we suggest checking if a new or updated edition of this document is available at Lika Electronic s.r.l.'s website. Lika Electronic s.r.l. assumes no responsibility for any errors or omissions in this document. Critical evaluation of this manual by the user is welcomed. Your comments assist us in preparation of future documentation, in order to make it as clear and complete as possible. Please send an e-mail to the following address info@lika.it for submitting your comments, suggestions and criticisms.

The logo for Lika Electronic s.r.l. consists of the word "lika" in a bold, lowercase, sans-serif font. The letter "i" has a solid black dot above it. The logo is positioned in the bottom right corner of the page.

General contents

User's guide.....	1
General contents.....	3
Subject Index.....	5
Typographic and iconographic conventions.....	6
Preliminary information.....	7
1 - Safety summary.....	8
1.1 Safety.....	8
1.2 Electrical safety.....	8
1.3 Mechanical safety.....	9
2 - Identification.....	10
3 - Mounting instructions.....	11
3.1 AS36 encumbrance sizes.....	11
3.2 ASC36 encumbrance sizes.....	11
3.3 Solid shaft encoders AS36 model.....	12
3.4 Hollow shaft encoder ASC36 model.....	13
4 - Electrical connections.....	14
4.1 M12 connector.....	14
4.2 M8 cable specifications.....	14
4.3 GND connection.....	15
4.4 Zero setting/Preset input.....	15
4.5 Counting direction input.....	16
5 - SSI interface.....	17
5.1 SSI (Synchronous Serial Interface).....	17
5.2 "MSB left aligned" protocol.....	18
5.3 Recommended transmission rates.....	19
5.4 Recommended SSI input circuit.....	20
6 - BiSS C-mode interface.....	21
6.1 XML file.....	21
6.2 Communication.....	21
6.3 Single Cycle Data SCD.....	22
6.3.1 SCD structure.....	22
Position.....	22
Error.....	22
Warning.....	22
CRC.....	23
6.4 Control Data CD.....	23
Register address.....	23
RW.....	23
DATA.....	23
CRC.....	24
6.5 Implemented registers.....	24
Preset.....	25
Preset setting enable.....	27
Serial number.....	28
Command.....	28
Save parameters.....	28

Save parameters and activate Preset.....	28
Device ID	28
Time-out	29
Manufacturer ID	29
6.6 Application notes.....	29
6.7 Recommended BiSS input circuit.....	30
7 - Default parameters list	31

Subject Index



C			
Command.....	28		
CRC.....	23p.		
D			
DATA.....	23		
Device ID.....	28		
E			
Error.....	22		
M			
Manufacturer ID.....	29		
P			
Position.....	22		
		Preset.....	25
		Preset setting enable.....	27
		R	
		Register address.....	23
		RW.....	23
		S	
		Save parameters.....	28
		Save parameters and activate Preset.....	28
		Serial number.....	28
		T	
		Time-out.....	29
		W	
		Warning.....	22

Typographic and iconographic conventions

In this guide, to make it easier to understand and read the text the following typographic and iconographic conventions are used:

- parameters and objects both of Lika device and interface are coloured in **GREEN**;
- alarms are coloured in **RED**;
- states are coloured in **FUCSIA**.

When scrolling through the text some icons can be found on the side of the page: they are expressly designed to highlight the parts of the text which are of great interest and significance for the user. Sometimes they are used to warn against dangers or potential sources of danger arising from the use of the device. You are advised to follow strictly the instructions given in this guide in order to guarantee the safety of the user and ensure the performance of the device. In this guide the following symbols are used:

	This icon, followed by the word WARNING , is meant to highlight the parts of the text where information of great significance for the user can be found: user must pay the greatest attention to them! Instructions must be followed strictly in order to guarantee the safety of the user and a correct use of the device. Failure to heed a warning or comply with instructions could lead to personal injury and/or damage to the unit or other equipment.
	This icon, followed by the word NOTE , is meant to highlight the parts of the text where important notes needful for a correct and reliable use of the device can be found. User must pay attention to them! Failure to comply with instructions could cause the equipment to be set wrongly: hence a faulty and improper working of the device could be the consequence.
	This icon is meant to highlight the parts of the text where suggestions useful for making it easier to set the device and optimize performance and reliability can be found. Sometimes this symbol is followed by the word EXAMPLE when instructions for setting parameters are accompanied by examples to clarify the explanation.

Preliminary information

This guide is designed to provide the most complete and exhaustive information the operator needs to correctly and safely install and operate the **AS36 and ASC36 series absolute encoders**.

To make it easier to read and understand the text, this guide can be divided into three main sections.

In the first section some general information concerning the safety, the mechanical installation and the electrical connection as well as tips for setting up and running properly and efficiently the unit are provided.

In the second section, entitled **SSI interface**, both general and specific information is given on the SSI interface.

In the third section, entitled **BiSS C-mode interface**, both general and specific information is given on the BiSS C-mode interface. In this section the parameters implemented in the unit are fully described.

1 - Safety summary



1.1 Safety

- Always adhere to the professional safety and accident prevention regulations applicable to your country during device installation and operation;
- installation and maintenance operations have to be carried out by qualified personnel only, with power supply disconnected and stationary mechanical parts;
- device must be used only for the purpose appropriate to its design: use for purposes other than those for which it has been designed could result in serious personal and/or the environment damage;
- high current, voltage and moving mechanical parts can cause serious or fatal injury;
- warning! Do not use in explosive or flammable areas;
- failure to comply with these precautions or with specific warnings elsewhere in this manual violates safety standards of design, manufacture, and intended use of the equipment;
- Lika Electronic assumes no liability for the customer's failure to comply with these requirements.



1.2 Electrical safety

- Turn off power supply before connecting the device;
- connect according to explanation in the "4 - Electrical connections" section on page 14;
- if not used, connect Zero setting/Preset and Counting direction inputs to 0Vdc;
 - to set the zero/preset, connect Zero setting/Preset input to +Vdc for 100 μ s at least, then disconnect +Vdc; normally voltage must be at 0Vdc; zero/preset must be set after Counting direction; we suggest setting the zero/preset when the encoder shaft is not running;
 - Counting direction: CW increasing count (viewed from shaft side): connect to 0Vdc; CCW increasing count: connect to +Vdc;
- in compliance with the 2014/30/EU norm on electromagnetic compatibility, following precautions must be taken:
 - before handling and installing, discharge electrical charge from your body and tools which may come in touch with the device;
 - power supply must be stabilized without noise, install EMC filters on device power supply if needed;
 - always use shielded cables (twisted pair cables whenever possible);
 - avoid cables runs longer than necessary;
 - avoid running the signal cable near high voltage power cables;
 - mount the device as far as possible from any capacitive or inductive noise source, shield the device from noise source if needed;
 - to guarantee a correct working of the device, avoid using strong magnets on or near by the unit;
 - minimize noise by connecting the shield and/or the connector housing and/or the frame to ground. Make sure that ground is not affected by noise. The connection point to ground can be situated both on the device side and



on user's side. The best solution to minimize the interference must be carried out by the user.



1.3 Mechanical safety

- Install the device following strictly the information in the "3 - Mounting instructions" section on page 11;
- mechanical installation must be carried out with stationary mechanical parts;
- do not disassemble the encoder;
- do not tool the encoder or its shaft;
- delicate electronic equipment: handle with care; do not subject the device and the shaft to knocks or shocks;
- respect the environmental characteristics declared by manufacturer;
- unit with solid shaft: in order to guarantee the maximum reliability over time of the mechanical parts, we recommend a flexible coupling to be installed to connect the encoder and the installation shaft; make sure the misalignment tolerances of the flexible coupling are respected;
- unit with hollow shaft: the encoder can be mounted directly on a shaft whose diameter has to respect the technical characteristics specified in the purchase order and clamped by means of the collar and the fixing plate into which an anti-rotation pin has to be inserted.

2 - Identification

Device can be identified through the **order code** and the **serial number** printed on the label applied to its body. Information is listed in the delivery document too. Please always quote the order code and the serial number when reaching Lika Electronic. For any information on the technical characteristics of the product refer to the technical catalogue.



Warning: encoders having order code ending with "/Sxxx" may have mechanical and electrical characteristics different from standard and be supplied with additional documentation for special connections (Technical Info).

3 - Mounting instructions



WARNING

Installation must be carried out by qualified personnel only, with power supply disconnected and mechanical parts compulsorily in stop.

3.1 AS36 encumbrance sizes

(values are expressed in millimetres)

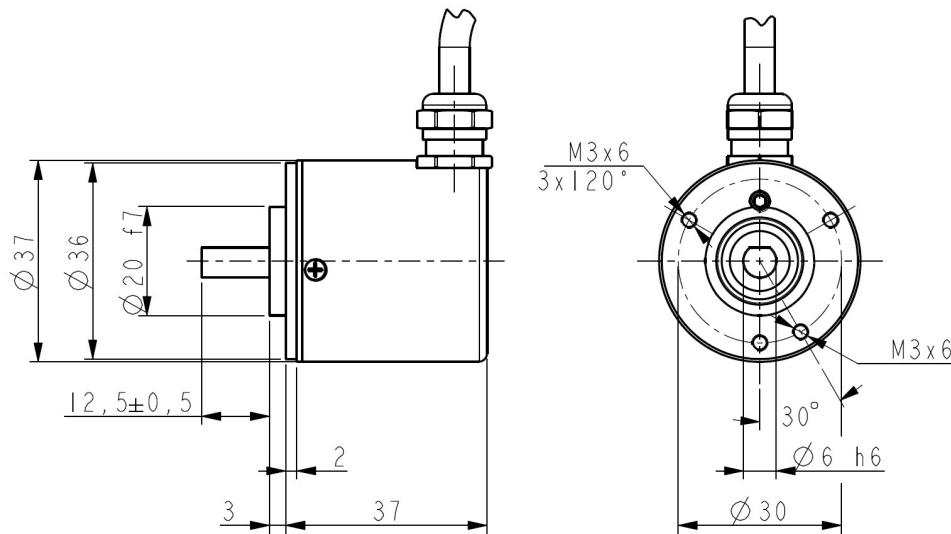

3.2 ASC36 encumbrance sizes

(values are expressed in millimetres)

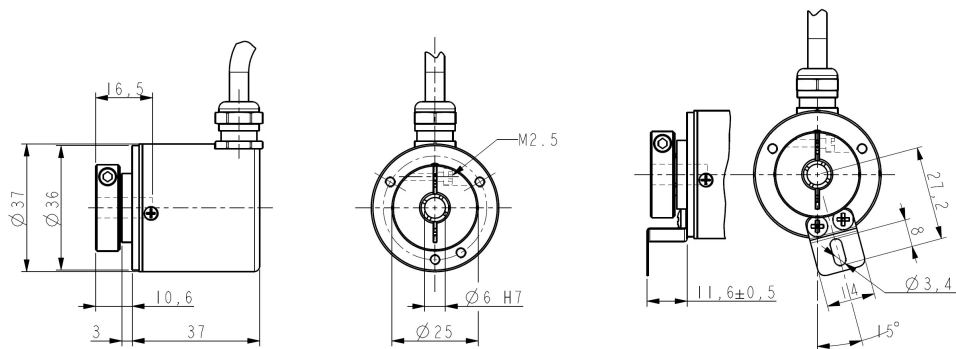

3.3 Solid shaft encoders AS36 model

- Mount the flexible coupling **1** on the encoder shaft;
- fix the encoder to the flange **2** by means of screws **3**;
- secure the flange **2** either to the motor or to the mounting support;
- mount the flexible coupling **1** on the motor shaft;
- make sure the alignment tolerances of the flexible coupling **1** are respected.

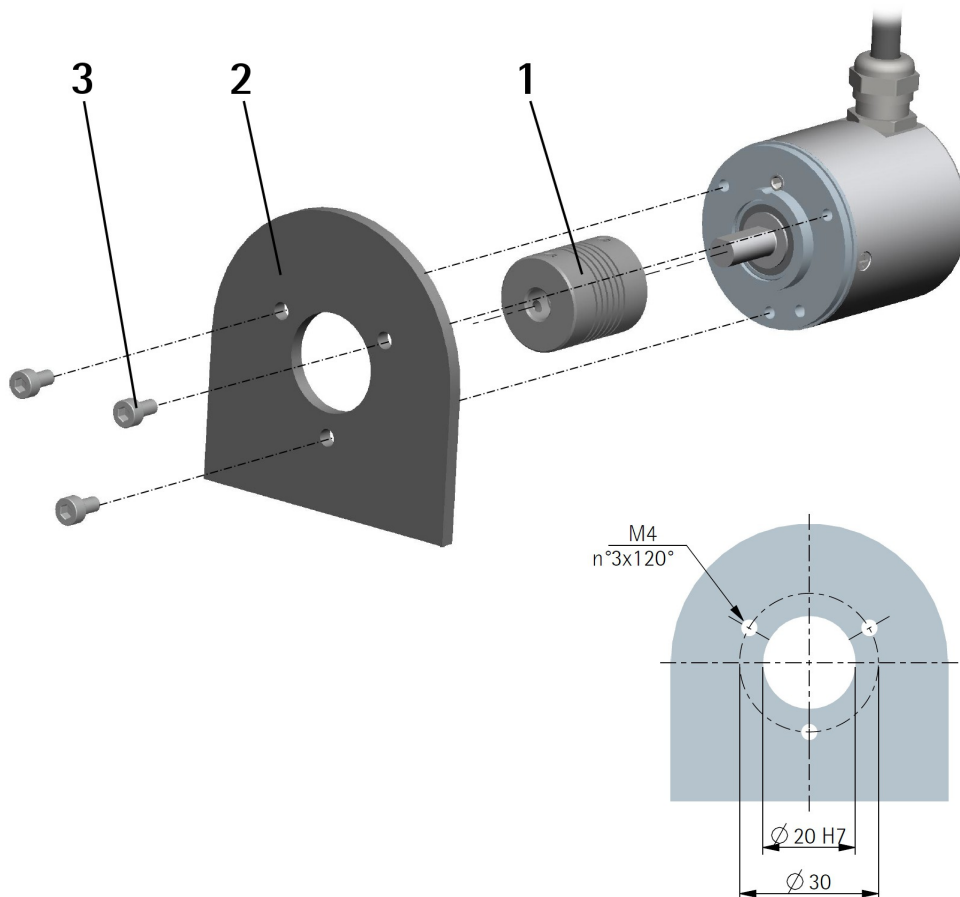

NOTE

In order to guarantee reliability over time of the encoder mechanical parts, we recommend a flexible coupling to be installed between the encoder and the motor shaft. Make sure the misalignment tolerances of the flexible coupling are respected.

3.4 Hollow shaft encoder ASC36 model

- Mount the encoder on the motor shaft. Avoid forcing the encoder shaft;
- fasten the fixing plate **4** to the rear of the motor using a M3 cylindrical head screw **5**;
- fix the collar **3** to the encoder shaft by means of the screw.

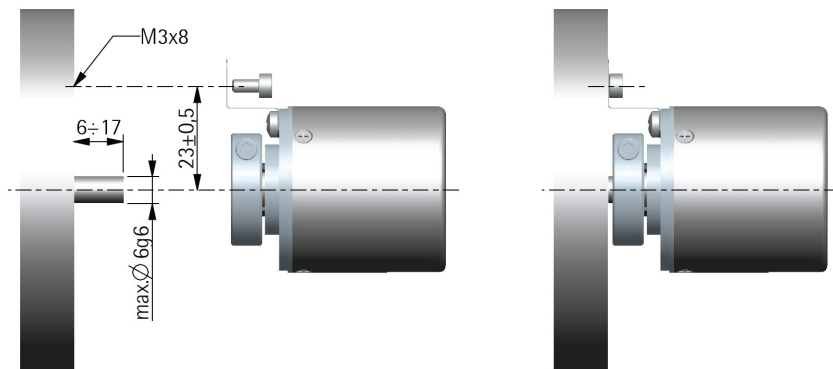
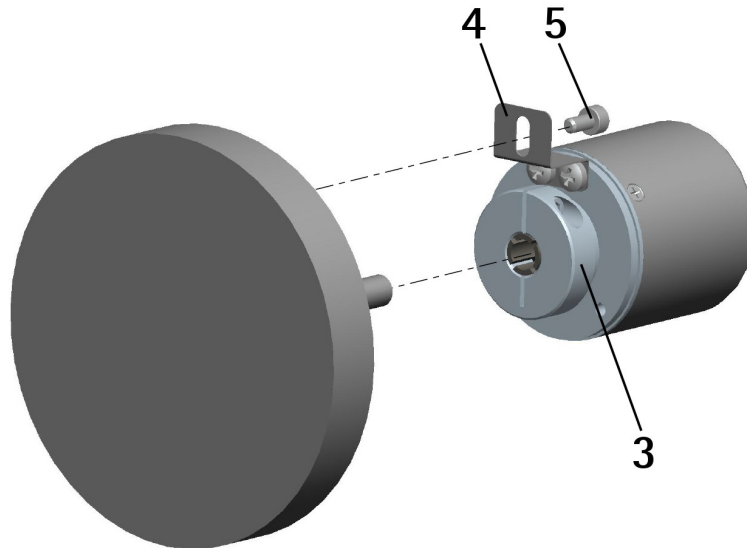

NOTE

You are strongly advised not to carry out any mechanical operations (drilling, milling, etc.) on the encoder shaft. This could cause serious damages to the internal parts and an immediate warranty loss. Please contact our technical personnel for the complete availability of "custom made" shafts.

4 - Electrical connections



WARNING

Power supply must be turned off before performing any electrical connection! If wires of unused signals come in contact, irreparable damage could be caused to the device. Thus they must be cut at different lengths and insulated singularly.

Function	M12 8-pin	M8 type cable
0Vdc	1	Black
+Vdc ¹	2	Red
Clock IN + / MA +	3	Yellow
Clock IN - / MA -	4	Blue
Data OUT + / SLO +	5	Green
Data OUT - / SLO -	6	Orange
Zero setting/Preset	7	White
Counting direction	8	Grey
Shield	Case	Shield

1 See the order code for power supply voltage level



EXAMPLE

AS36xx/BG1-... +Vdc = +5Vdc ± 5%

AS36xx/BG2-... +Vdc = +10Vdc +30Vdc



WARNING

When the power is switched on, above 3V supply voltage +Vdc must be applied with a slew rate larger than 50V/s.

4.1 M12 connector

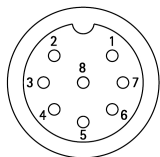

M12 8-pin connector
A coding
Male frontal side

4.2 M8 cable specifications

Model : LIKA HI-FLEX sensor cable type M8

Cross section : 2 x 0.22 mm² + 6 x 0.14 mm² (24/26AWG)

Jacket	: Matt Polyurethane (TPU) halogen free, oil, hydrolysis, abrasion resistant
Shield	: Tinned copper braid, coverage > 85%
Outer diameter	: 5.3 ÷ 5.6 mm (0.209" ÷ 0.220")
Min. bending radius	: outer diameter x 7.5
Work temperature: dyn	-40 +90°C (-40° +194°F) / fix -50 +90°C (-58° +194°F)
Conductor resistance	: <90 Ω/Km (0.22 mm ²), <148 Ω/Km (0.14 mm ²)

4.3 GND connection

Minimize noise by connecting the shield and/or the connector housing and/or the frame to ground. Make sure that ground is not affected by noise. The connection point to ground can be situated both on the device side and on user's side. The best solution to minimize the interference must be carried out by the user.

4.4 Zero setting/Preset input

The output position information at a point in the shaft rotation can be set either to 0 (SSI interface) or to a desired value called preset (BiSS C-mode interface; the preset value must be set next to the **Preset** registers, see on page 25). The Zero setting/Preset input allows the operator to activate the zero/preset value through an input signal sent by a PLC or other controller. To activate the zero setting/preset function, connect the Zero setting/Preset input to +Vdc for 100 µs at least, then disconnect +Vdc; normally voltage must be at 0Vdc; Zero setting/Preset must be set after Counting direction. We suggest setting the zero/preset when the encoder shaft is not running. If not used, connect the Zero setting/Preset input to 0Vdc.



WARNING

In the BiSS C-mode interface model, the Zero setting/Preset input is active only when the **Preset setting enable** register is set to 01; otherwise the hardware function is disabled.



NOTE

In the BiSS interface the preset can be activated also by using the **Save parameters and activate Preset** function of the **Command** register. For detailed information please refer to the **Preset** registers on page 25 and to the **Command** register on page 28.

4.5 Counting direction input

Counting direction input allows to set whether the position value output by the encoder increases when the encoder shaft rotates clockwise (CW) or counter-clockwise (CCW). If the Counting direction input is connected to 0Vdc, the position value increases when the encoder shaft rotates clockwise; on the contrary, if the Counting direction input is connected to +Vdc, the position value increases when the encoder shaft rotates counter-clockwise. CW and CCW rotations are viewed from shaft end. If not used, connect the Counting direction input to 0Vdc.

**WARNING**

After having set a new counting direction you are required to set a new zero/preset value.

5 - SSI interface

Order codes: ASx36xx/BGx-...
ASx36xx/GGx-...

5.1 SSI (Synchronous Serial Interface)



SSI (the acronym for **Synchronous Serial Interface**) is a synchronous point-to-point serial interface engineered for unidirectional data transmission between one Master and one Slave.

Developed in the first eighties, it is based on the RS-422 serial standard. Its most peculiar feature is that data transmission is achieved by synchronizing both the Master and the Slave devices to a common clock signal generated by the controller; in this way the output information is clocked out at each controller's request. Furthermore only two pairs of twisted wires are used for data and clock signals, thus a six-wire cable is required.

The main advantages in comparison with parallel or asynchronous data transmissions are:

- less conductors are required for transmission;
- less electronic components;
- possibility of insulating the circuits galvanically by means of optocouplers;
- high data transmission frequency;
- hardware interface independent from the resolution of the absolute encoder.

Furthermore the differential transmission increases the noise immunity and decreases the noise emissions. It allows multiplexing from several encoders, thus process controls are more reliable with simplified line design and easier data management.

Data transmission is carried out as follows.

At the first falling edge of the clock signal (1, the logic level changes from high to low) the absolute position value is stored while at the following rising edge (2) the transmission of data information begins starting from the MSB.

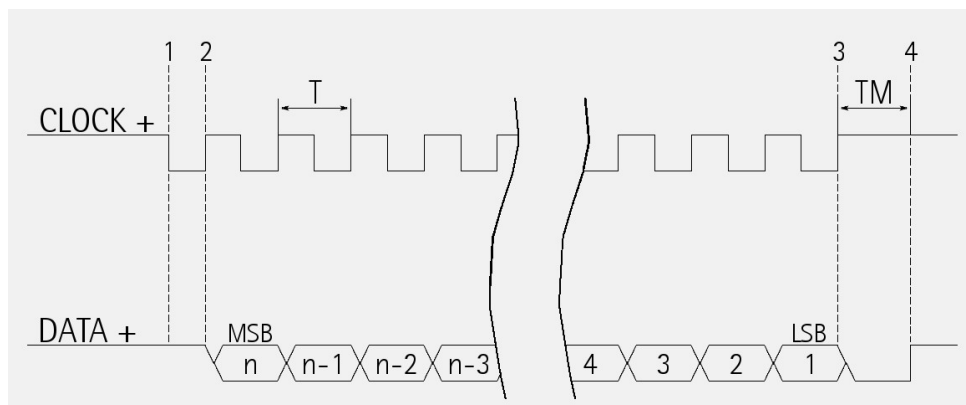

At each change of the clock signal and at each subsequent rising edge (2) one bit is clocked out at a time, up to LSB, so completing the data word transmission. The cycle ends at the last rising edge of the clock signal (3). This means that up to $n + 1$ rising edges of the clock signals are required for each data word transmission (where n is the bit resolution); for instance, a 13-bit encoder needs 14 clock edges. If the number of clocks is greater than the number of bits of the data word, then the system will send a zero (low logic level signal) at each additional clock, zeros will either lead (LSB ALIGNED protocol) or follow (MSB ALIGNED protocol) or lead and/or follow (TREE FORMAT protocol) the data word. After the period T_m monoflop time, having a typical duration of 12 μ sec, calculated from the end of the clock signal transmission, the encoder is then ready for the next transmission and therefore the data signal is switched high.

The clock signal has a typical logic level of 5V, the same as the output signal which has customarily a logic level of 5V in compliance with RS-422 standard. The output code can be either Binary or Gray (see the order code).

5.2 "MSB left aligned" protocol

"MSB left aligned" protocol allows to left align the bits, beginning from MSB (most significant bit) to LSB (least significant bit); MSB is then sent at the first clock cycle. If the number of clock signals is higher than the data bits, then unused bits are forced to logic level low (0) and follow the data word. This protocol can be used in encoders having any resolution.

The number of clocks to be sent to the encoder must equal the number of data bits at least, anyway it can be higher, as stated previously. The great advantage of this protocol over the TREE format or the LSB RIGHT ALIGNED format is that data can be transmitted with a minimum time loss and T_m monoflop time can immediately follow the data bits without any additional clock signal.

The length of the word is variable according to the resolution, as shown in the following table.

Model	Length of the word	Max. number of information
ASx3616/...	16 bits	65,536
ASx3617/...	17 bits	131,072
ASx3619/...	19 bits	524,288
ASx3620/...	20 bits	1,048,576

The output code can be GRAY or BINARY (see the order code).

Structure of the position information

ASx3616/...	bit	15	...	0
ASx3617/...	bit	16	...	0
ASx3619/...	bit	18	...	0
ASx3620/...	bit	19	...	0
	value	MSB	...	LSB

5.3 Recommended transmission rates

The SSI interface has a frequency of data transmission ranging between 100 kHz and 4 MHz.

CLOCK IN and DATA OUT signals comply with the "EIA standard RS-422".

The SSI clock frequency (baud rate) depends on the length of the cable and must comply with the technical information reported in the following table:

Cable length	Baud rate
< 50 m	< 400 kHz
< 100 m	< 300 kHz
< 200 m	< 200 kHz
< 400 m	< 100 kHz

The time interval between two Clock sequence transmissions must be at least 16 μ s ($T_p > 16 \mu$ s).

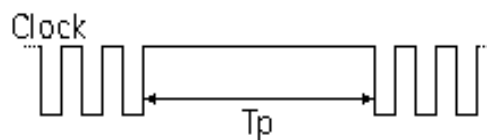

5.4 Recommended SSI input circuit

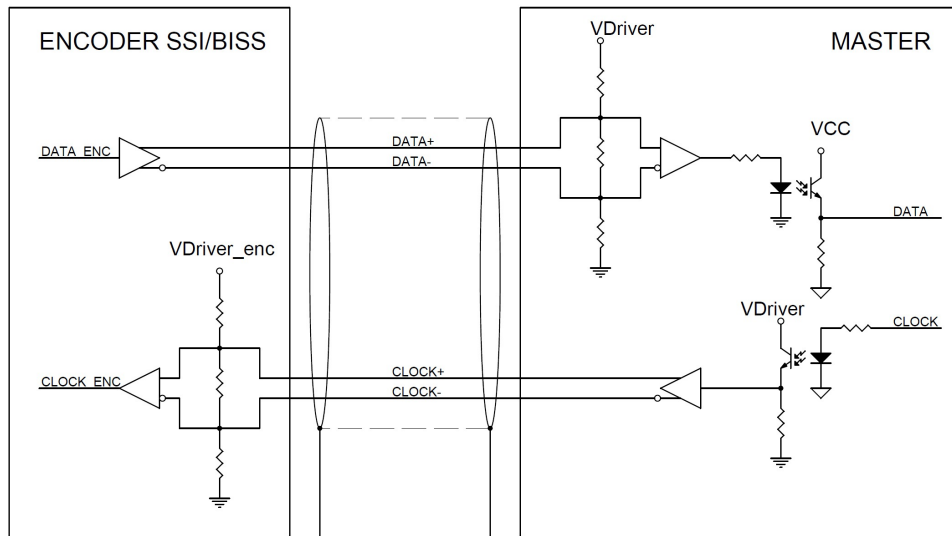

6 - BiSS C-mode interface

Order code: ASx36xx/SCx-...

Lika encoders are always Slave devices and comply with the "BiSS C-mode interface" and the "Standard encoder profile".

Refer to the official BiSS website for all information not listed in this manual (www.biss-interface.com).

The device is designed to work in a point-to-point configuration and has to be installed in a "single Master, single Slave" network.

CLOCK IN (MA) and DATA OUT (SLO) signal levels are according to the "EIA standard RS-422".



WARNING

Never install the encoder in a "single Master, multi Slave" network.

6.1 XML file

BiSS C-mode encoders are supplied with a XML file **idbiss4C69.xml**, it must be installed in your BiSS master device. Download the XML file from www.lika.it > Rotary encoders > Absolute encoders > SSI and BiSS interface.

6.2 Communication

The BiSS C-mode protocol uses two types of data transmission protocols:

- **Single Cycle Data (SCD):** it is the main data transmission protocol. It is used to send process data from the Slave to the Master. For any information refer to the "6.3 Single Cycle Data SCD" section on page 22.
- **Control Data (CD):** transmission of a single bit following the SCD data. It is used to read or write data into the registers of the Slave. For any information refer to the "6.4 Control Data CD" section on page 23.

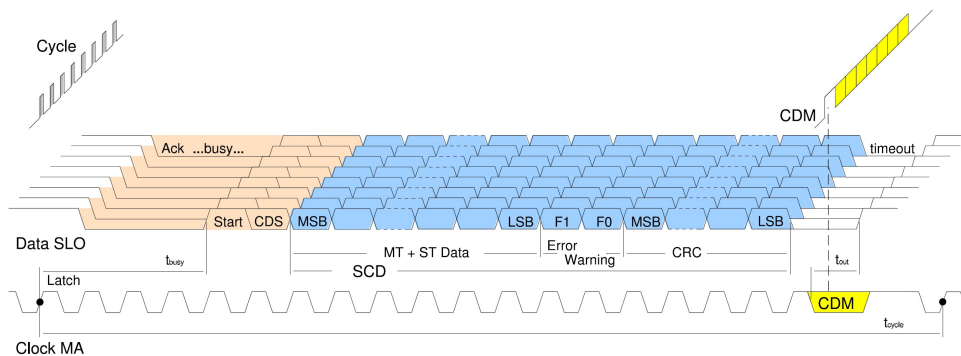

6.3 Single Cycle Data SCD

SCD structure is different according to the resolution of the ASx36 model encoder.

6.3.1 SCD structure

SCD data has a variable length according to the resolution of the encoder. It consists of the following elements: position value (**Position**), 1 error bit nE (**Error**), 1 warning bit nW (**Warning**) and a 6-bit CRC Cyclic Redundancy Check (**CRC**).

16-bit encoder model (ASx36 16)

bit	23 ... 8	7	6	5 ... 0
function	Position	Error	Warning	CRC

17-bit encoder model (ASx36 17)

bit	24 ... 8	7	6	5 ... 0
function	Position	Error	Warning	CRC

19-bit encoder model (ASx36 19)

bit	26 ... 8	7	6	5 ... 0
function	Position	Error	Warning	CRC

20-bit encoder model (ASx36 20)

bit	27 ... 8	7	6	5 ... 0
function	Position	Error	Warning	CRC

Position

It is the process data transmitted by the Slave to the Master. It has a variable length according to the resolution of the encoder.

The transmission starts with MSB (most significant bit) and ends with LSB (least significant bit).

Error

Not used (nE = "1"). It is 1-bit long.

Warning

Not used (nW = "1"). It is 1-bit long.

CRC

Correct transmission control (inverted output). Cyclic Redundancy Check is an error checking which is the result of a "Redundancy Checking" calculation performed on the message contents. This is intended to check whether transmission has been performed properly. It is 6-bit long.

Polynomial: X^6+X^1+1 (binary: 1000011)

Logic circuit

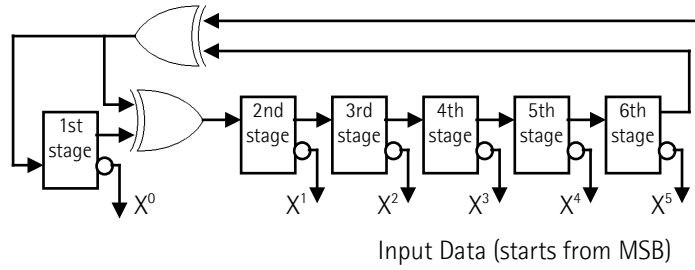

6.4 Control Data CD

Main control data is described in this section. Please refer to the official BiSS documents for complete CD structure: "BiSS C Protocol Description" in the BiSS homepage.

Register address

It sets what register you need to read or to write. It is 7-bit long.

RW

RW = "01": when you need to write in the register.

RW = "10": when you need to read from the register.

It is 2-bit long.

DATA

When you need to write in a register (**RW** = "01"), it allows to set the value to be written in the register (transmitted from the Master to the Slave).

When you need to read from a register (**RW** = "10"), it shows the value read in the register (transmitted from the Slave to the Master).

It is 8-bit long.

Data bit structure:

bit	7	0
	MSB	LSB

CRC

Correct transmission control (inverted output). Cyclic Redundancy Check is an error checking which is the result of a "Redundancy Checking" calculation performed on the message contents. This is intended to check whether transmission has been performed properly. It is 4-bit long.

Polynomial: X^4+X^1+1 (binary: 10011)

Logic circuit:

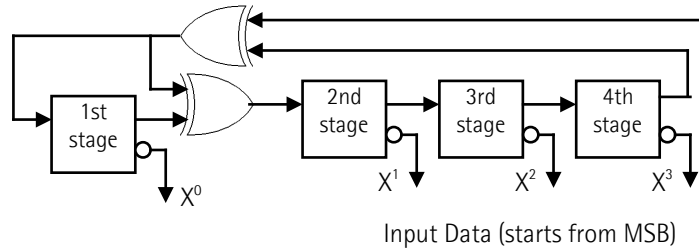

6.5 Implemented registers

Register (hex)	Function
10 ... 14	Preset
40	Preset setting enable
60 ... 63	Serial number
77	Command
78 - 79	Device ID
7C	Time-out
7E - 7F	Manufacturer ID

All registers described in this section are listed as follows:

Function name

[Address, Attribute]

Description of the function and specification of the default value.

- Address: the register address is expressed in hexadecimal notation.
- Attribute: ro = read only
 rw = read and write
 wo = write only
- Default parameter value is written in **bold**.

Preset

[10 ... 14, rw]



WARNING

You are allowed to enter a value next to the **Preset** registers only after having set the value "01" next to the **Preset setting enable** register. As soon as you have entered the desired preset value, you must set the value "00" next to the **Preset setting enable** register and then save data.

These registers allow the operator to set the Preset value. The preset function is meant to assign a desired value to a physical position of the encoder. The chosen physical position (i.e. the transmitted position value) will get the value set next to these registers and all the previous and following positions will get a value according to it. For instance, this can be useful for getting the zero point of the encoder and the zero point of the application to match. The preset value will be set for the position of the encoder in the moment when the command is sent through the **Save parameters and activate Preset** function of the **Command** register (or through the Preset input signal, see the "4.4 Zero setting/Preset input" section on page 15).

After having entered a value next to the **Preset** registers you can either save it without activating the preset function or both save and activate it at the same time. Use the **Save parameters** function (set "01" in the **Command** register) to save the new Preset value without activating it.

Use the **Save parameters and activate Preset** function (set "02" in the **Command** register) to both save and activate the new Preset value.

The Preset value must be lower than the "total hardware resolution".
Default = **00 00 00h**.



NOTE

We suggest setting the preset when the encoder shaft is not running.



NOTE

Please note that the bit structure of the **Preset** registers is as follows:

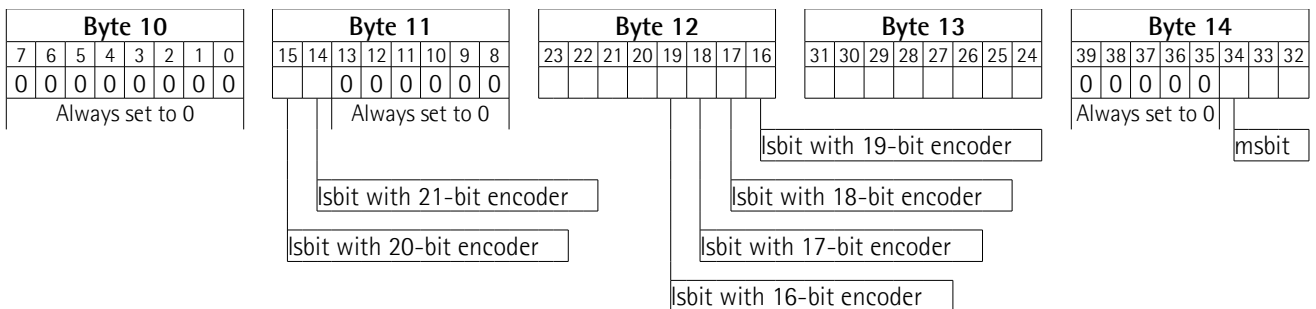



NOTE

Please note that:

- msbit is always bit 34 of byte 14;
- lsbit changes according to the encoder resolution;
- binary values must be entered:
 - from bit 34 to bit 32 in byte 14;
 - from bit 31 to bit 24 in byte 13;
 - from bit 23 to bit 19 (or to bit 18, 17 or 16, according to the encoder resolution) in byte 12;
 - bit 15 (and bit 14, according to the encoder resolution) in byte 11;
- bits from 39 to 35 in byte 14 are always set to 0;
- bits from 13 to 8 in byte 11 are always set to 0;
- all bits in byte 10 are always set to 0.

To properly set the **Preset** value see the following example.



PRESET SETTING EXAMPLE

In the 19-bit resolution encoder ($2^{19} = 524,288$ information), you want to set the following **Preset** value = $50,000_{10} = C350h = 1100\ 0011\ 0101\ 0000_2$.

1. As previously stated, first of all you must enable the setting of the **Preset** registers by entering the value "01" next to the **Preset setting enable** register.

2. Then enter the **Preset** value ($50,000_{10} = 1100\ 0011\ 0101\ 0000_2$) according to the structure explained above. Please note that you must enter the value in the 19-bit long format (according to the encoder resolution), so it is: 0001100001101010000 in binary notation. See the following table:

Byte 10								Byte 11								Byte 12								Byte 13								Byte 14							
7	6	5	4	3	2	1	0	15	14	13	12	11	10	9	8	23	22	21	20	19	18	17	16	31	30	29	28	27	26	25	24	39	38	37	36	35	34	33	32
0	0	0	0	0	0	0	0	0	0	0	0	0	0	0	0	0	1	0	1	0	0	0	0	1	1	0	0	0	0	1	1	0	0	0	0	0	0	0	0
																lsbit with 19-bit encoder								msbit															

3. It results that you must enter the following hexadecimal value:

Byte 10								Byte 11								Byte 12								Byte 13								Byte 14							
0	0	0	0	0	0	0	0	0	0	0	0	0	0	0	0	0	1	0	1	0	0	0	0	1	1	0	0	0	0	1	1	0	0	0	0	0	0	0	0
0		0		0		0		5		0		C		3		0		0																					

4. Then, before saving the entered data, set the value "00" next to the **Preset setting enable** register.

5. To save the new Preset value, you must use the **Save parameters** function in the **Command** register (set "01" in the **Command** register).
6. Otherwise, to both save and activate the new Preset value at the same time, you must use the **Save parameters and activate Preset** function in the **Command** register (set "02" in the **Command** register).

Function	ADDR	DATA Tx
Preset setting enable	40	01

Writing in the Preset registers	10	00
	11	00
	12	50
	13	C3
	14	00

Preset setting enable	40	00
-----------------------	----	----

Save parameters function in the Command register	77	01
--	----	----

or

Save parameters and activate Preset function in the Command register	77	02
--	----	----

Preset setting enable

[40, wo]

It allows the operator to enable both the setting of the **Preset** registers (see on page 25) and the preset setting hardware function (see on page 15). You are allowed to set a new preset value only after having entered the value "01" next to this **Preset setting enable** register. As soon as you have entered the desired preset value, you must set the value "00" next to this **Preset setting enable** register and then save data.

Serial number

[60 ... 63, ro]

These registers contain the serial number of the device expressed in hexadecimal notation.

Register 60: year of production.

Register 61: week of production.

Registers 62 and 63: serial number in ascending order.

Command

[77, wo]

Value	Function
01	Save parameters
02	Save parameters and activate Preset

After having set a new value in any register use the **Save parameters** function in the **Command** register to save the new value. Set "01" in the **Command** register.

After having set a new value in any register use the **Save parameters and activate Preset** function in the **Command** register to both save the new value and activate the preset function at the same time. Set "02" in the **Command** register.

After having sent the command the register is set back to "00" automatically. Wait 30 ms at least (EPROM writing time) before activating a new function.

Device ID

[78 – 79, ro]

These registers contain the Device ID. Identification name is expressed hexadecimal ASCII code.

Register	78	79
Hex	41	53
ASCII	A	S

Time-out**[7C, rw]**

It allows to set the minimum interval time between two transmission sequences. After having set the desired time-out value, save data using the **Save parameters** function (**Command** register = "01").

Time-out	Bit 7 ... bit 2	Bit 1	Bit 0
16 μ s	0 ... 0	0	0
8 μ s	0 ... 0	0	1
2 μs (default)	0 ... 0	1	0
1 μ s	0 ... 0	1	1

**NOTE**

You can save the entered time-out value also by using the **Save parameters and activate Preset** function in the **Command** register (**Command** register = "02"). Please note that in this case you both save time-out data and activate the preset function (see on page 25).

Manufacturer ID**[7E – 7F, ro]**

These registers contain the Manufacturer ID. Identification name is expressed in hexadecimal ASCII code.

Register	7E	7F
Hex	4C	69
ASCII	L	i

Li = Lika Electronic

6.6 Application notes

Data transmission:

Parameter	Value
Clock Frequency	Min 200 KHz, max 10 MHz
BiSS time-out	It can be set up, see Time-out register

6.7 Recommended BiSS input circuit

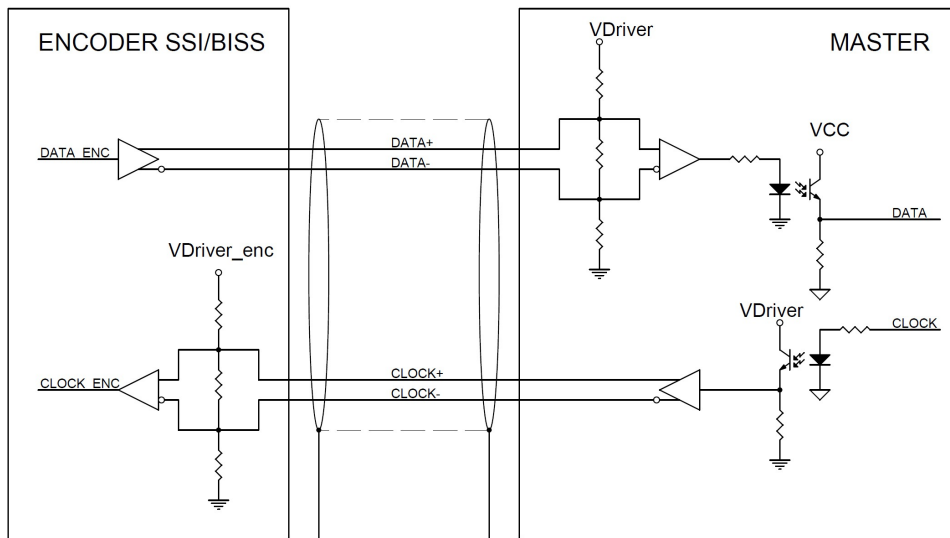

7 - Default parameters list

BiSS C-mode interface

Parameters list	Default value *		
Preset	00 00 00 00 00		
Preset setting enable	00		
Time-out	02		

* All values are expressed in hexadecimal notation.

Document release	Release date	Description	HW	SW	Interface
1.0	03.04.2013	First issue	1.0	-	-
1.1	03.11.2014	SSI information, general update	1.0	-	-
1.2	18.03.2015	BiSS interface XML installation file available	1.0	-	-
1.3	17.07.2017	General review, 20-bit version, new order codes, new preset setting	2.0	-	-



This device is to be supplied by a Class 2 Circuit or Low-Voltage Limited Energy or Energy Source not exceeding 30 Vdc. Refer to the order code for supply voltage rate.

Ce dispositif doit être alimenté par un circuit de Classe 2 ou à très basse tension ou bien en appliquant une tension maxi de 30Vcc. Voir le code de commande pour la tension d'alimentation.



Dispose separately

lika

Lika Electronic

Via S. Lorenzo, 25 • 36010 Carrè (VI) • Italy

Tel. +39 0445 806600

Fax +39 0445 806699



info@lika.biz • www.lika.biz