

User's guide

# AM36

# AMC36

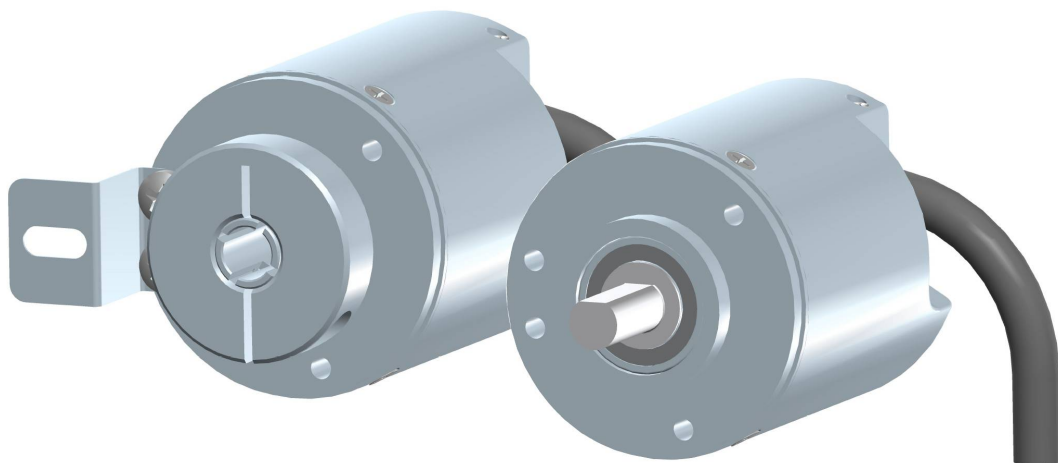

Smart encoders & actuators

This publication was produced by Lika Electronic s.r.l. 2014. All rights reserved. Tutti i diritti riservati. Alle Rechte vorbehalten. Todos los derechos reservados. Tous droits réservés.

This document and information contained herein are the property of Lika Electronic s.r.l. and shall not be reproduced in whole or in part without prior written approval of Lika Electronic s.r.l. Translation, reproduction and total or partial modification (photostat copies, film and microfilm included and any other means) are forbidden without written authorisation of Lika Electronic s.r.l.

The information herein is subject to change without notice and should not be construed as a commitment by Lika Electronic s.r.l. Lika Electronic s.r.l. reserves the right to make all modifications at any moments and without forewarning.

This manual is periodically reviewed and revised. As required we suggest checking if a new or updated edition of this document is available at Lika Electronic s.r.l.'s website. Lika Electronic s.r.l. assumes no responsibility for any errors or omissions in this document. Critical evaluation of this manual by the user is welcomed. Your comments assist us in preparation of future documentation, in order to make it as clear and complete as possible. Please send an e-mail to the following address [info@lika.it](mailto:info@lika.it) for submitting your comments, suggestions and criticisms.



# General contents

User's guide.....	1
General contents.....	3
Subject Index.....	5
Typographic and iconographic conventions.....	6
Preliminary information.....	7
1 - Safety summary.....	8
Safety.....	8
Electrical safety.....	8
Mechanical safety.....	9
2 - Identification.....	10
3 - Mounting instructions.....	11
3.1 AM36 encumbrance sizes.....	11
3.2 AMC36 encumbrance sizes.....	11
3.3 Solid shaft encoders AM36 model.....	12
3.4 Hollow shaft encoder AMC36 model.....	13
4 - Electrical connections.....	14
4.1 M12 connector.....	14
4.2 Cable specifications.....	14
4.3 GND connection.....	14
4.4 Zero setting/Preset input.....	15
4.5 Counting direction input.....	15
5 - SSI interface.....	17
5.1 SSI (Synchronous Serial Interface).....	17
5.2 "MSB left aligned" protocol.....	18
5.3 Recommended transmission rates.....	19
5.4 Recommended SSI input circuit.....	19
6 - BiSS C-mode interface.....	20
6.1 XML file.....	20
6.2 Communication.....	20
6.3 Single Cycle Data SCD.....	21
6.3.1 SCD structure.....	21
Position.....	21
Error.....	21
Warning.....	21
CRC.....	22
6.4 Control Data CD.....	22
Register address.....	22
RW.....	22
DATA.....	22
CRC.....	23
6.5 Implemented registers.....	23
Profile ID.....	24
Serial number.....	24
Command.....	24
Normal operational state.....	24
Save parameters on EEPROM.....	24
Save parameters and activate Preset.....	24
Load and save default parameters.....	24
Configuration.....	25

Enable preset.....	25
Output code.....	26
Counting direction.....	26
Information per revolution.....	27
Number of revolutions.....	28
Preset.....	29
Device type.....	31
N° of bits used for singleturn resolution.....	31
N° of bits used for multiturn resolution.....	31
Device ID.....	31
Manufacturer ID.....	32
6.6 Application notes.....	32
6.7 Recommended BiSS input circuit.....	32
7 - Default parameters list.....	33

# Subject Index



<b>C</b>			
Command.....	24	N° of bits used for singleturn resolution.....	31
Configuration.....	25	Normal operational state.....	24
Counting direction.....	26	Number of revolutions.....	28
CRC.....	22 e seg.	<b>O</b>	
<b>D</b>		Output code.....	26
DATA.....	22	<b>P</b>	
Device ID.....	31	Position.....	21
Device type.....	31	Preset.....	29
<b>E</b>		Profile ID.....	24
Enable preset.....	25	<b>R</b>	
Error.....	21	Register address.....	22
<b>I</b>		RW.....	22
Information per revolution.....	27	<b>S</b>	
<b>L</b>		Save parameters and activate Preset.....	24
Load and save default parameters.....	24	Save parameters on EEPROM.....	24
<b>N</b>		Serial number.....	24
N° of bits used for multiturn resolution.....	31	<b>W</b>	
		Warning.....	21

# Typographic and iconographic conventions

In this guide, to make it easier to understand and read the text the following typographic and iconographic conventions are used:

- parameters and objects both of Lika device and interface are coloured in **ORANGE**;
- alarms are coloured in **RED**;
- states are coloured in **FUCSIA**.

When scrolling through the text some icons can be found on the side of the page: they are expressly designed to highlight the parts of the text which are of great interest and significance for the user. Sometimes they are used to warn against dangers or potential sources of danger arising from the use of the device. You are advised to follow strictly the instructions given in this guide in order to guarantee the safety of the user and ensure the performance of the device. In this guide the following symbols are used:

	This icon, followed by the word <b>WARNING</b> , is meant to highlight the parts of the text where information of great significance for the user can be found: user must pay the greatest attention to them! Instructions must be followed strictly in order to guarantee the safety of the user and a correct use of the device. Failure to heed a warning or comply with instructions could lead to personal injury and/or damage to the unit or other equipment.
	This icon, followed by the word <b>NOTE</b> , is meant to highlight the parts of the text where important notes needful for a correct and reliable use of the device can be found. User must pay attention to them! Failure to comply with instructions could cause the equipment to be set wrongly: hence a faulty and improper working of the device could be the consequence.
	This icon is meant to highlight the parts of the text where suggestions useful for making it easier to set the device and optimize performance and reliability can be found. Sometimes this symbol is followed by the word <b>EXAMPLE</b> when instructions for setting parameters are accompanied by examples to clarify the explanation.

# Preliminary information

This guide is designed to provide the most complete and exhaustive information the operator needs to correctly and safely install and operate the **AM36 and AMC36 series absolute encoders**.

To make it easier to read and understand the text, this guide can be divided into three main sections. In the first section some general information concerning the safety, the mechanical installation and the electrical connection as well as tips for setting up and running properly and efficiently the unit are provided.

In the second section, entitled **SSI interface**, both general and specific information is given on the SSI interface.

In the third section, entitled **BiSS C-mode interface**, both general and specific information is given on the BiSS C-mode interface. In this section the parameters implemented in the unit are fully described.

## 1 - Safety summary



### Safety

- Always adhere to the professional safety and accident prevention regulations applicable to your country during device installation and operation;
- installation and maintenance operations have to be carried out by qualified personnel only, with power supply disconnected and stationary mechanical parts;
- device must be used only for the purpose appropriate to its design: use for purposes other than those for which it has been designed could result in serious personal and/or the environment damage;
- high current, voltage and moving mechanical parts can cause serious or fatal injury;
- warning! Do not use in explosive or flammable areas;
- failure to comply with these precautions or with specific warnings elsewhere in this manual violates safety standards of design, manufacture, and intended use of the equipment;
- Lika Electronic s.r.l. assumes no liability for the customer's failure to comply with these requirements.



### Electrical safety

- Turn off power supply before connecting the device;
- connect according to explanation in section "4 - Electrical connections";
- if not used, connect Zero setting/Preset and Counting direction inputs to 0VDC;
  - to set the zero/preset, connect Zero setting/Preset input to +VDC for 100  $\mu$ s at least, then disconnect +VDC; normally voltage must be at 0VDC; zero/preset must be set after Counting direction; we suggest setting the zero/preset when the encoder shaft is not running;
  - Counting direction: CW increasing count (viewed from shaft side): connect to 0VDC; CCW increasing count: connect to +VDC;
- in compliance with the 2004/108/EC norm on electromagnetic compatibility, following precautions must be taken:
  - before handling and installing, discharge electrical charge from your body and tools which may come in touch with the device;
  - power supply must be stabilized without noise, install EMC filters on device power supply if needed;
  - always use shielded cables (twisted pair cables whenever possible);
  - avoid cables runs longer than necessary;
  - avoid running the signal cable near high voltage power cables;
  - mount the device as far as possible from any capacitive or inductive noise source, shield the device from noise source if needed;
  - to guarantee a correct working of the device, avoid using strong magnets on or near by the unit;
  - minimize noise by connecting the shield and/or the connector housing and/or the frame to ground. Make sure that ground is not affected by noise. The connection point to ground can be situated both on the device side and on user's side. The best solution to minimize the interference must be carried out by the user.







### Mechanical safety

- Install the device following strictly the information in the section "3 - Mounting instructions";
- mechanical installation has to be carried out with stationary mechanical parts;
- do not disassemble the encoder;
- do not tool the encoder or its shaft;
- delicate electronic equipment: handle with care; do not subject the device and the shaft to knocks or shocks;
- respect the environmental characteristics declared by manufacturer;
- unit with solid shaft: in order to guarantee the maximum reliability over time of the mechanical parts, we recommend a flexible coupling to be installed to connect the encoder and the installation shaft; make sure the misalignment tolerances of the flexible coupling are respected;
- unit with hollow shaft: the encoder can be mounted directly on a shaft whose diameter has to respect the technical characteristics specified in the purchase order and clamped by means of the collar and the fixing plate into which an anti-rotation pin has to be inserted.

## 2 - Identification

Device can be identified through the **order code** and the **serial number** printed on the label applied to its body. Information is listed in the delivery document too. Please always quote the order code and the serial number when reaching Lika Electronic. For any information on the technical characteristics of the product refer to the technical catalogue.



**Warning:** encoders having order code ending with "/Sxxx" may have mechanical and electrical characteristics different from standard and be supplied with additional documentation for special connections (Technical Info).

### 3 - Mounting instructions



#### WARNING

Installation has to be carried out by qualified personnel only, with power supply disconnected and mechanical parts compulsorily in stop.

#### 3.1 AM36 encumbrance sizes

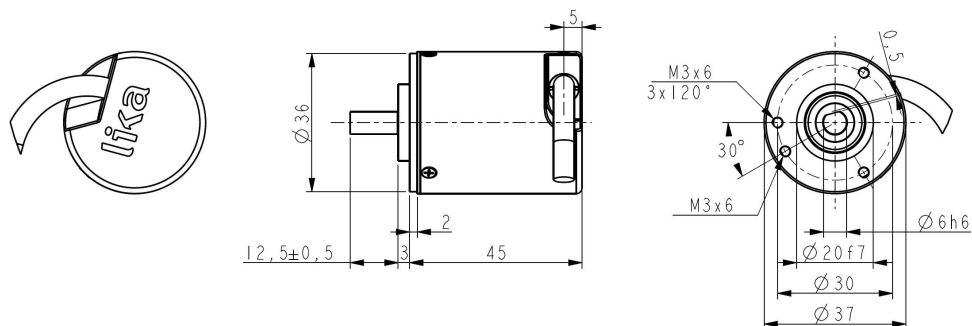

#### 3.2 AMC36 encumbrance sizes

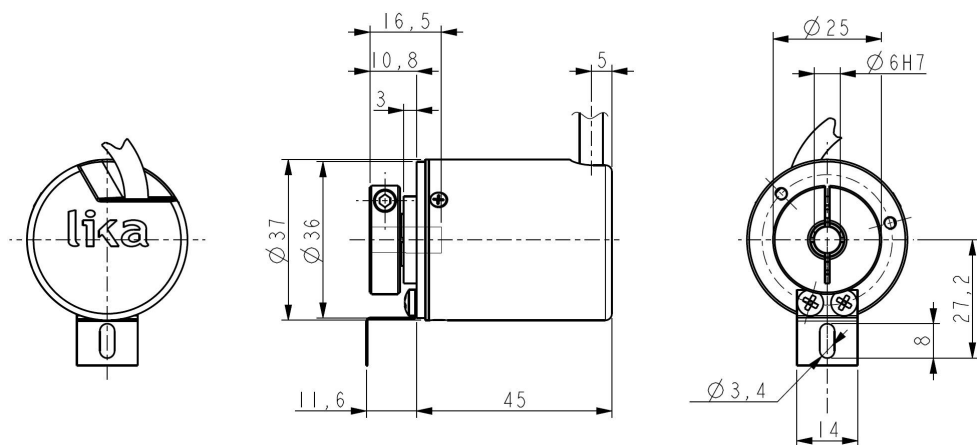

### 3.3 Solid shaft encoders AM36 model

- Mount the flexible coupling **1** on the encoder shaft;
- fix the encoder to the flange **2** by means of screws **3**;
- secure the flange **2** either to the motor or to the mounting support;
- mount the flexible coupling **1** on the motor shaft;
- make sure the misalignment tolerances of the flexible coupling **1** are respected.

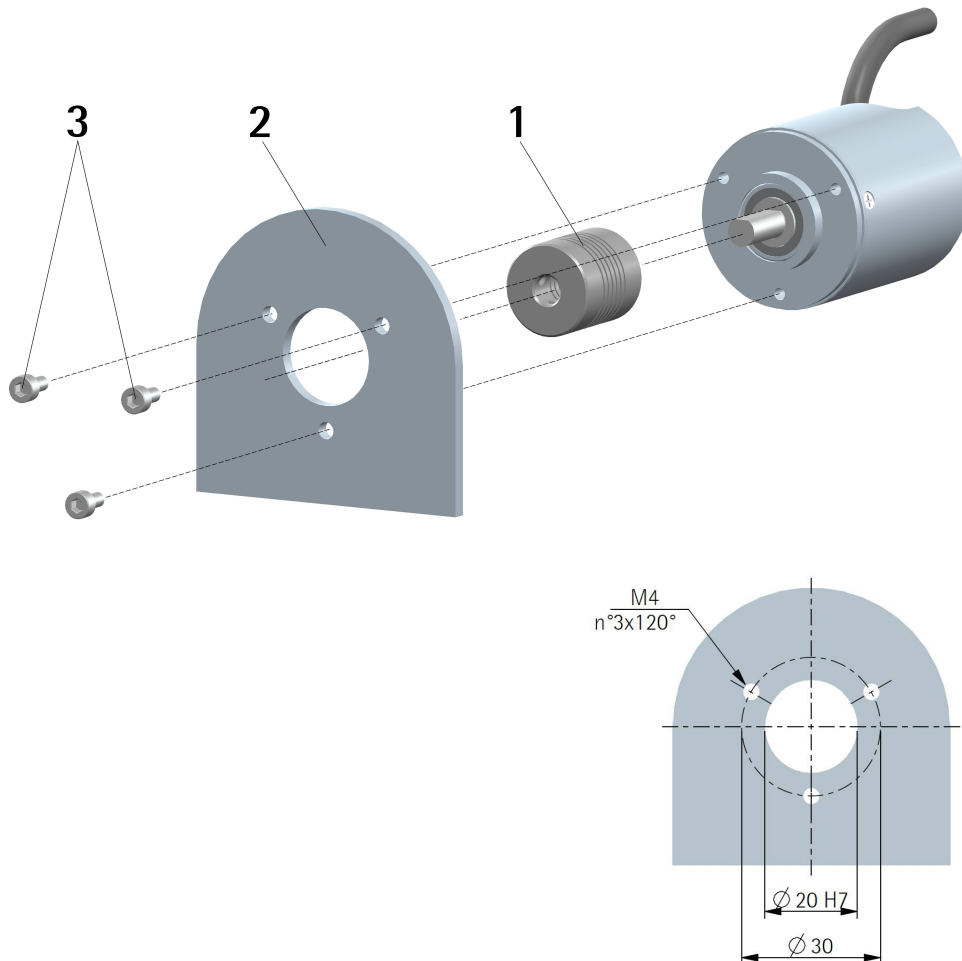

#### NOTE

In order to guarantee reliability over time of the encoder mechanical parts, we recommend a flexible coupling to be installed between the encoder and the motor shaft.

### 3.4 Hollow shaft encoder AMC36 model

- Mount the encoder on the motor shaft. Avoid forcing the encoder shaft;
- fasten the fixing plate **4** to the rear of the motor using a M3 cylindrical head screw **5**;
- fix the collar **3** to the encoder shaft by means of the screw.

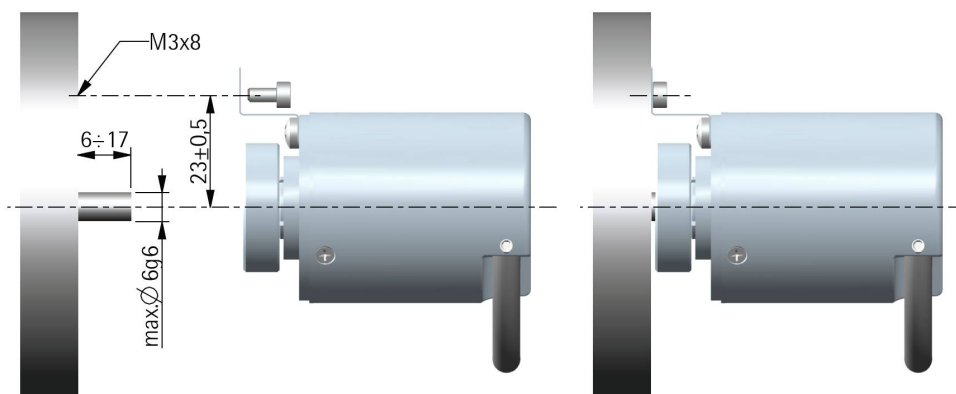
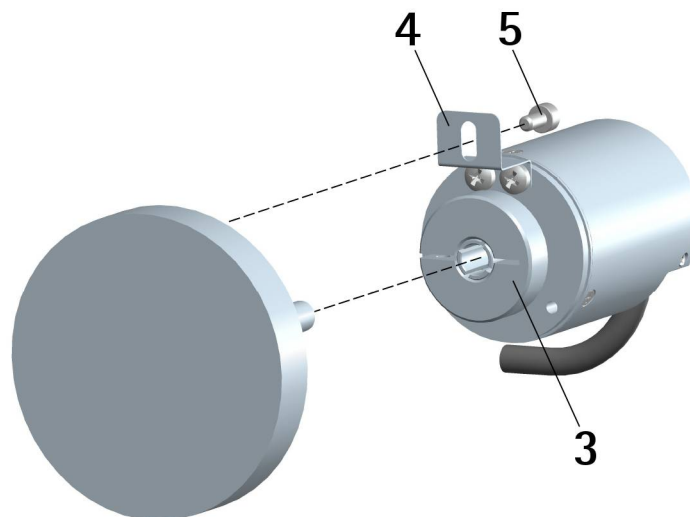

### 4 - Electrical connections



#### WARNING

Power supply must be turned off before performing any electrical connection! If wires of unused signals come in contact, irreparable damage could be caused to the device. Thus they must be cut at different lengths and insulated singularly.

Function	M12 8-pin	M8 type cable
0VDC	1	Black
+10VDC +30VDC	2	Red
Clock IN +	3	Yellow
Clock IN -	4	Blue
Data OUT +	5	Green
Data OUT -	6	Orange
Zero setting/Preset	7	White
Counting direction	8	Grey
Shield	Case	Shield

#### 4.1 M12 connector

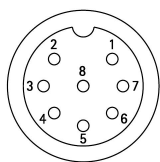

M12 8-pin connector  
A coding  
Male frontal side

#### 4.2 Cable specifications

Model : LIKA HI-FLEX SENSOR CABLE (M8 type cable)  
 Wires : 6 x 0.14 mm<sup>2</sup> + 2 x 0.22 mm<sup>2</sup> (26/24 AWG)  
 Shield : tinned copper braid  
 External diameter : Ø 5.3mm ÷ 5.6mm  
 Impedance : 148 Ω/km (0.14 mm<sup>2</sup>), 90 Ω/km (0.22 mm<sup>2</sup>)  
 Minimum bend radius : Ø x 7.5

#### 4.3 GND connection

Minimize noise by connecting the shield and/or the connector housing and/or the frame to ground. Make sure that ground is not affected by noise. The connection point to ground can be situated both on the device side and on user's side. The best solution to minimize the interference must be carried out by the user.

### 4.4 Zero setting/Preset input

The output position information at a point in the shaft rotation can be set either to 0 (SSI interface) or to a desired value called preset (BiSS C interface; the preset value has to be set next to the registers **Preset**, see on page 29). The Zero setting/Preset input allows the operator to activate the zero setting/preset function by using an input signal sent by a PLC or other controller. To activate the zero setting/preset function, connect the Zero setting/Preset input to +VDC for 100  $\mu$ s at least, then disconnect +VDC; normally voltage must be at 0VDC; Zero setting/Preset must be set after Counting direction. We suggest setting the zero setting/preset function when the encoder shaft is not running. If not used, connect the Zero setting/Preset input to 0VDC.



#### WARNING

In the BiSS C interface model, the Zero setting/Preset input is active only when the **Enable preset** software function in the **Configuration** register is enabled (the bit 2 in the register 49 = 0, see on page 25); otherwise the hardware function is disabled.



#### NOTE

In the BiSS C interface model, the preset can be activated also by using the **Save parameters and activate Preset** function of the **Command** register. For detailed information please refer to the **Command** register on page 24, the **Configuration** register on page 25 and the **Preset** registers on page 29.

### 4.5 Counting direction input

It is also known as Complementary input.

The Counting direction input allows to set whether the position value output by the encoder increases when the encoder shaft rotates clockwise (CW) or counterclockwise (CCW). If the Counting direction input is connected to 0VDC, the position value increases when the encoder shaft rotates clockwise; on the contrary, if the Counting direction input is connected to +VDC, the position value increases when the encoder shaft rotates counterclockwise. CW and CCW rotations are viewed from shaft end. If not used, connect the Counting direction input to 0VDC.



#### WARNING

In the BiSS interface the counting direction can be set also via software by setting the bit 6 **Counting direction** in the register 49 **Configuration**. The **Counting direction** parameter implies that the Counting direction input is set to 0VDC. Otherwise the resulting will be contrary to what is expected or intended. Thus when the counting direction is set to CW -**Counting direction** = 0 = CW-, if the Counting direction input has LOW logic level (0VDC) the encoder will provide the increasing count when the shaft is turning clockwise (and the decreasing count when the shaft is turning counter-clockwise); on the contrary if the Counting direction input has HIGH logic level (+VDC) the encoder will

provide the increasing count when the shaft is turning counter-clockwise (and the decreasing count when the shaft is turning clockwise). When the option CCW is set -**Counting direction** = 1 = CCW-, if the Counting direction input has LOW logic level (0VDC) the encoder will provide the increasing count when the shaft is turning counter-clockwise (and the decreasing count when the shaft is turning clockwise); on the contrary if the Counting direction input has HIGH logic level (+VDC) the encoder will provide the increasing count when the shaft is turning clockwise (and the decreasing count when the shaft is turning counter-clockwise).

**WARNING**

After having changed the counting direction you are required to set a new zero/Preset.



## 5 - SSI interface

Order codes: **AMx36xx/4096-BG-...**  
**AMx36xx/4096-GG-...**

### 5.1 SSI (Synchronous Serial Interface)



SSI (the acronym for **Synchronous Serial Interface**) is a synchronous point-to-point serial interface engineered for unidirectional data transmission between one Master and one Slave. Developed in the first eighties, it is based on the RS-422 serial standard. Its most peculiar feature is that data transmission is achieved by synchronizing both the Master and the Slave devices to a common clock signal generated by the controller; in this way the output information is clocked out at each controller's request. Furthermore only two pairs of twisted wires are used for data and clock signals, thus a six-wire cable is required. The main advantages in comparison with parallel or asynchronous data transmissions are:

- less conductors are required for transmission;
- less electronic components;
- possibility of insulating the circuits galvanically by means of optocouplers;
- high data transmission frequency;
- hardware interface independent from the resolution of the absolute encoder.

Furthermore the differential transmission increases the noise immunity and decreases the noise emissions. It allows multiplexing from several encoders, thus process controls are more reliable with simplified line design and easier data management.

Data transmission is carried out as follows.

At the first falling edge of the clock signal (1, the logic level changes from high to low) the absolute position value is stored while at the following rising edge (2) the transmission of data information begins starting from the MSB.

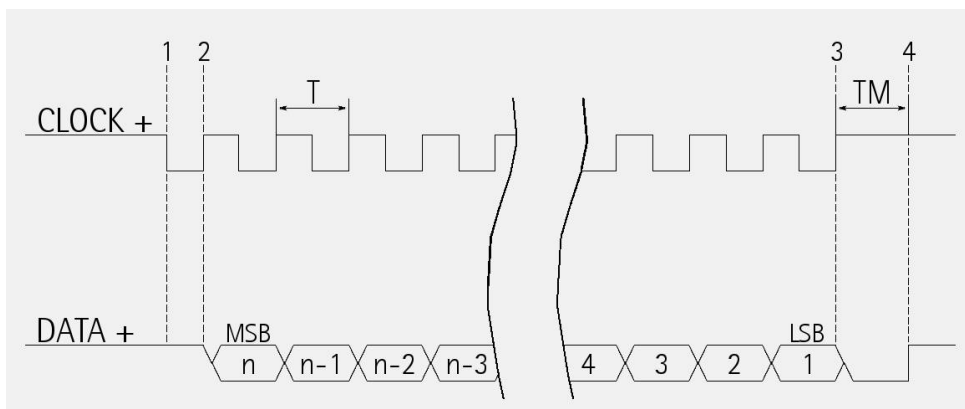

At each change of the clock signal and at each subsequent rising edge (2) one bit is clocked out at a time, up to LSB, so completing the data word transmission. The cycle ends at the last rising edge of the clock signal (3). This means that up to  $n + 1$  rising edges of the clock signals are required for each data word transmission (where  $n$  is the bit resolution); for instance, a 13-bit encoder needs 14 clock edges. If the number of clocks is greater than the number of bits of the data word, then the system will send a zero (low logic level signal) at each additional clock, zeros will either lead (LSB ALIGNED protocol) or follow (MSB ALIGNED protocol) or lead and/or follow (TREE FORMAT protocol) the data word. After the period  $T_m$  monoflop time, having a typical duration of 12  $\mu$ sec, calculated from the end of the clock signal transmission, the encoder is then ready for the next transmission and therefore the data signal is switched high.

The clock signal has a typical logic level of 5V, the same as the output signal which has customarily a logic level of 5V in compliance with RS-422 standard. The output code can be either Binary or Gray (see the order code).

### 5.2 "MSB left aligned" protocol

"MSB left aligned" protocol allows to left align the bits, beginning from MSB (most significant bit) to LSB (least significant bit); MSB is then sent at the first clock cycle. If the number of clock signals is higher than the data bits, then unused bits are forced to logic level low (0) and follow the data word. This protocol can be used in encoders having any resolution.

The number of clocks to be sent to the encoder must equal the number of data bits at least, anyway it can be higher, as stated previously. The great advantage of this protocol over the TREE format or the LSB RIGHT ALIGNED format is that data can be transmitted with a minimum time loss and  $T_m$  monoflop time can immediately follow the data bits without any additional clock signal.

The length of the word is variable according to the resolution, as shown in the following table.

Model	Length of the word	Max. number of information
AMx3616/4096-...	28 bits	268,425,456
AMx3619/4096-...	31 bits	2,147,483,648

The output code can be GRAY or BINARY (see the order code).

Structure of the position information

AMx3616/4096-...	bit	28	...	1
AMx3619/4096-...	bit	31	...	1
	value	MSB	...	LSB

### 5.3 Recommended transmission rates

The SSI interface has a frequency of data transmission ranging between 100 kHz and 3 MHz.

The CLOCK signal and the DATA signal comply with the "EIA standard RS-422".

The SSI clock frequency (baud rate) depends on the length of the cable and must comply with the technical information reported in the following table:

Cable length	Baud rate
< 50 m	< 400 kHz
< 100 m	< 300 kHz
< 200 m	< 200 kHz
< 400 m	< 100 kHz

The time interval between two Clock sequence transmissions must be at least 12  $\mu$ s ( $T_p > 12 \mu$ s).

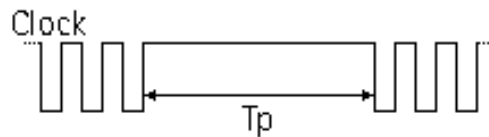

### 5.4 Recommended SSI input circuit

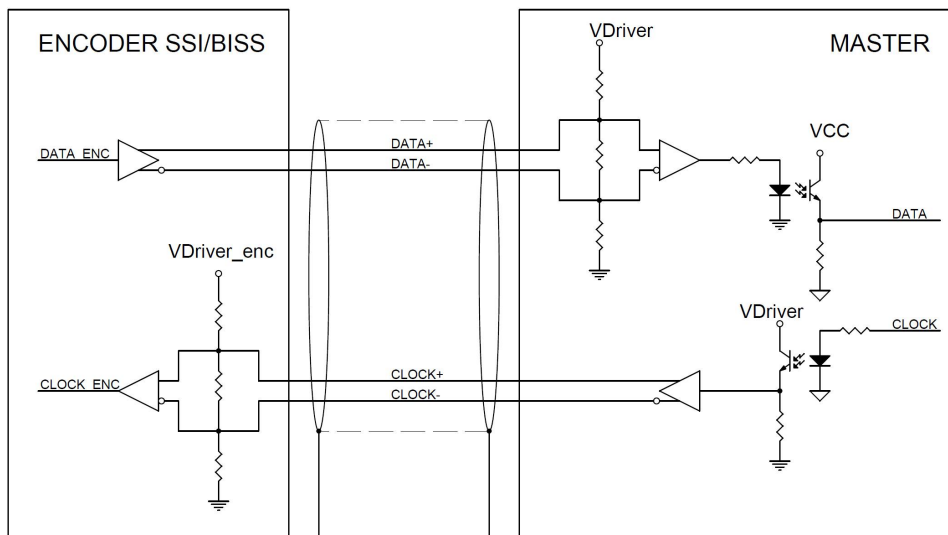

## 6 - BiSS C-mode interface

Order code: **AMx36xx/xxxx-I7-...**

Lika encoders are always Slave devices and comply with the "BiSS C-mode interface" and the "Standard encoder profile".

Refer to the official BiSS website for all information not listed in this manual ([www.biss-interface.com](http://www.biss-interface.com)).

The device is designed to work in a point-to-point configuration and has to be installed in a "single Master, single Slave" network.

CLOCK IN (MA) and DATA OUT (SLO) signal levels are according to the "EIA standard RS-422".



### WARNING

Never install the encoder in a "single Master, multi Slave" network.

### 6.1 XML file

BiSS C-mode encoders are supplied with a XML file **idbiss4C69.xml**, it must be installed in your BiSS master device. Download the XML file from [www.lika.it](http://www.lika.it) > Rotary encoders > Absolute encoders > SSI and BiSS interface.

### 6.2 Communication

The BiSS C-mode protocol uses two types of data transmission protocols:

- **Single Cycle Data (SCD):** it is the main data transmission protocol. It is used to send process data from the Slave to the Master. For any information refer to the section "6.3 Single Cycle Data SCD" on page 21.
- **Control Data (CD):** transmission of a single bit following the SCD data. It is used to read or write data into the registers of the Slave. For any information refer to the section "6.4 Control Data CD" on page 22.

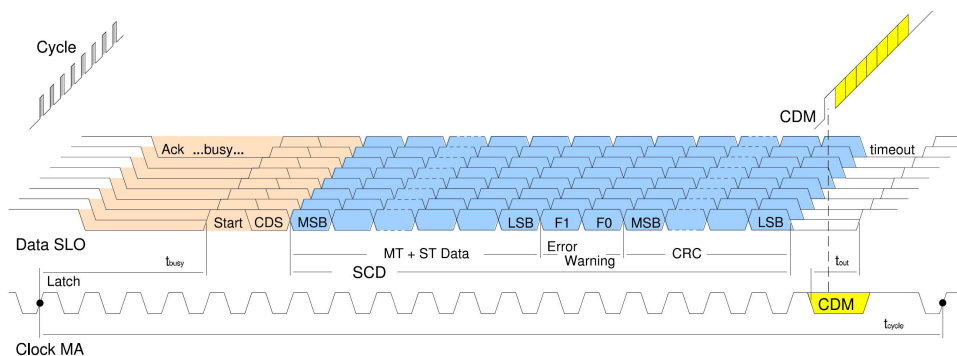

## 6.3 Single Cycle Data SCD

SCD structure is different according to the resolution of the AMx36 model encoders.

### 6.3.1 SCD structure

SCD data (44-bit long at the most) has variable length according to the resolution of the encoder. It consists of the following elements: position value (**Position**), 1 error bit nE (**Error**), 1 warning bit nW (**Warning**) and a 6-bit CRC Cyclical Redundancy Checking (**CRC**).

<b>bit</b>	<b>43 ... 8</b>	<b>7</b>	<b>6</b>	<b>5 ... 0</b>
<b>function</b>	<b>Position</b>	<b>Error</b>	<b>Warning</b>	<b>CRC</b>

#### Position

It is the process data transmitted by the Slave to the Master. It has a variable length according to the resolution of the encoder and is 36-bit long at the most.

The transmission starts with MSB (most significant bit) and ends with LSB (less significant bit).

<b>bit</b>	<b>43</b>	<b>...</b>	<b>...</b>	<b>8</b>
<b>value</b>	<b>MSB</b>	<b>...</b>	<b>...</b>	<b>LSB</b>

#### Error

Not used (nE = "1"). It is 1-bit long.

#### Warning

Not used (nW = "1"). It is 1-bit long.

## CRC

Correct transmission control (inverted output). Cyclical Redundancy Checking is an error checking which is the result of a "Redundancy Checking" calculation performed on the message contents. This is intended to check whether transmission has been performed properly. It is 6-bit long.

Polynomial:  $X^6+X^1+1$  (binary: 1000011)

## Logic circuit

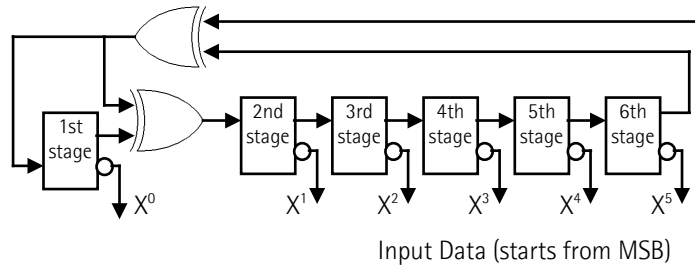

## 6.4 Control Data CD

Main control data is described in this section. Please refer to the official BiSS documents for complete CD structure: "BiSS C Protocol Description" in the BiSS homepage.

## Register address

It sets what register you need either to read or to write. It is 7-bit long.

## RW

**RW** = "01": when you need to write in the register.

**RW** = "10": when you need to read from the register.

It is 2-bit long.

## DATA

When you need to write in a register (**RW** = "01"), it allows to set the value to be written in the register (transmitted by the Master to the Slave).

When you need to read from a register (**RW** = "10"), it shows the value read in the register (transmitted by the Slave to the Master).

It is 8-bit long.

## Data bit structure:

<b>bit</b>	<b>7</b>	...	...	<b>0</b>
	MSB	...	...	LSB

### CRC

Correct transmission control (inverted output). Cyclical Redundancy Checking is an error checking which is the result of a "Redundancy Checking" calculation performed on the message contents. This is intended to check whether transmission has been performed properly. It is 4-bit long.

Polynomial:  $X^4+X^1+1$  (binary: 10011)

### Logic circuit:

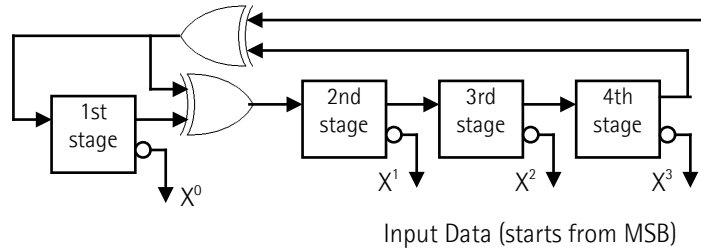

### 6.5 Implemented registers

Register (hex)	Function
42 - 43	Profile ID
44 ... 47	Serial number
48	Command
49	Configuration
4B ... 4D	Information per revolution
4E - 4F	Number of revolutions
50 ... 54	Preset
55	Device type
56	N° of bits used for singleturn resolution
57	N° of bits used for multiturn resolution
78 ... 7D	Device ID
7E - 7F	Manufacturer ID

All registers described in this section are listed as follows:

#### Function name

#### [Address, Attribute]

Description of the function and specification of the default value.

- Address: the register address is expressed in hexadecimal notation.
- Attribute:
  - ro = read only
  - rw = read and write
  - wo = write only
- Default parameter value is written in **bold**.

### Profile ID

[42 - 43, ro]

These registers contain the identification code of the used profile.

Register	42	43
AMx36	00	00

See "Standard encoder profile", "data format", "Variant 0-24".

### Serial number

[44 ... 47, ro]

These registers contain the serial number of the device expressed in hexadecimal notation.

Register 44: year of production.

Register 45: week of production.

Registers 46 and 47: serial number in ascending order.

### Command

[48, wo]

Value	Function
00	Normal operational state
01	Save parameters on EEPROM
02	Save parameters and activate Preset
04	Load and save default parameters

After having set a new value in some register, use the **Save parameters on EEPROM** function in this register to store it. Set "01" in the **Command** register.

After having set a new value in some register and a Preset value, use the **Save parameters and activate Preset** function in this register to store the values and activate the preset at the same time. Set "02" in the **Command** register.



### WARNING

If you set a new singleturn or multiturn resolution and a new preset value at the same time and then use this **Save parameters and activate Preset** function in order to activate the preset, please consider that the system stores the new resolution values, but zero sets the preset value. Thus you need to enter it again.

**Load and save default parameters:** default parameters are set at the factory by Lika Electronic engineers to allow the operator to run the device for standard operation in a safe mode. As soon as the command is sent the default parameters are uploaded and activated. All parameters which have been set previously are overwritten, thus previously set values are lost. The complete list



of machine data and the relevant default parameters preset by Lika Electronic engineers are available on page 33. Set "04" in the register.



### WARNING

As soon as the **Load and save default parameters** command is sent, all parameters which have been set previously are overwritten, thus previously set values are lost!

As soon as the command is sent, the register is set back to "00" (**Normal operational state**) automatically.

Wait min. 30 ms (EPROM writing time) before using a new function.

Default = 00

### Configuration

[49, rw]

Any new setting in the **Configuration** register will be active immediately after transmission. Use the **Save parameters on EEPROM** function to store the new value permanently (set "01" in the register 48 **Command**).

Default = 20h = 00100000<sub>2</sub>

Bit	Function	bit = 0	bit = 1
0	Not used		
1	Not used		
2	<b>Enable preset</b>	<b>Enable</b>	Disable
3	Not used		
4	Not used		
5	<b>Output code</b>	Gray	<b>Binary</b>
6	<b>Counting direction</b>	<b>CW</b>	CCW
7	Not used		

### Enable preset

It enables / disables the preset function. When you need to enter a new preset value, you have first to enable the **Preset** registers. To do this set to 1 the bit 2 **Enable preset** in this register, then enter the wished preset value next to the **Preset** registers and finally send the **Save parameters and activate Preset** command (set "02" in the register 48) to confirm the changes and activate the preset.

For detailed information refer to the **Preset** parameter on page 29.

Default = 0 (Enable)



### NOTE

You can set the preset also by means of a signal from a PLC or a controller through the Zero setting/Preset input, see the section "4.4 Zero setting/Preset input" on page 15.

### Output code

The encoder provides the absolute position information in the desired code format: GRAY (0) or BINARY (1).

Default = 1 (Binary)

### Counting direction

It allows to set whether the position information output by the encoder increases when the shaft rotates clockwise or counter-clockwise. Clockwise and counter-clockwise rotations are viewed from the shaft. It is possible to choose the following options: 0 = CW and 1 = CCW. When the counting direction is set to CW (**Counting direction** = 0 = CW), the encoder will provide the increasing count when it turns clockwise; on the contrary when the counting direction is set to CCW (**Counting direction** = 1 = CCW), the encoder will provide the increasing count when it turns counter-clockwise.

Default = 0 (CW)



#### WARNING

The counting direction can be set also via hardware (see the Counting direction input, section "4.5 Counting direction input" on page 15). If not used, the Counting direction input must be connected to 0VDC. The **Counting direction** parameter implies that the Counting direction input is set to 0VDC. Otherwise the resulting will be contrary to what is expected or intended. Thus when the counting direction is set to CW -**Counting direction** = 0 = CW-, if the Counting direction input has LOW logic level (0VDC) the encoder will provide the increasing count when the shaft is turning clockwise (and the decreasing count when the shaft is turning counter-clockwise); on the contrary if the Counting direction input has HIGH logic level (+VDC) the encoder will provide the increasing count when the shaft is turning counter-clockwise (and the decreasing count when the shaft is turning clockwise). When the option CCW is set -**Counting direction** = 1 = CCW-, if the Counting direction input has LOW logic level (0VDC) the encoder will provide the increasing count when the shaft is turning counter-clockwise (and the decreasing count when the shaft is turning clockwise); on the contrary if the Counting direction input has HIGH logic level (+VDC) the encoder will provide the increasing count when the shaft is turning clockwise (and the decreasing count when the shaft is turning counter-clockwise).

For any information on the electrical connection of the Counting direction input refer to the section "4.5 Counting direction input" on page 15.



#### WARNING

After having set the new counting direction it is necessary to set also a new preset.



## CONFIGURATION SETTING EXAMPLE

You need to set the following parameters next to the **Configuration** register:

**Enable preset** = enable = 0

**Output code** = Binary = 1

**Counting direction** = CCW = 1

Thus you will have as follows:

Bit 0	= non usato	= 0
Bit 1	= non usato	= 0
Bit 2 <b>Enable preset</b>	= ENABLE	= 0
Bit 3	= non usato	= 0
Bit 4	= non usato	= 0
Bit 5 <b>Output code</b>	= BINARY	= 1
Bit 8 <b>Counting direction</b>	= CCW	= 1
Bit 7	= non usato	= 0

Therefore you must set 60h = 01100000<sub>2</sub>

1. Enter the value 60h = 01100000<sub>2</sub> next to this **Configuration** register.
2. Save the value by using the **Save parameters on EEPROM** function in the **Command** register (set "01" in the **Command** register).

Function	ADDR	DATA Tx
Writing in the Configuration register	49	60

Save parameters on EEPROM function in the Command register	48	1
--	----	---

## Information per revolution

[4B ... 4D, rw]

These registers allow to enter the number of information per revolution (singleturn resolution). You are allowed to enter any integer value which is the power of 2 (1, 2, 4, ..., 2048, 4096, ...) and is less than or equal to the number of physical information per revolution (= default value). Values which are not the power of 2 cannot be accepted. If you set a value greater than the maximum allowed value, then the parameter is forced to the default value.

The setting in the **Information per revolution** registers will be active immediately after transmission. Use the **Save parameters on EEPROM** function to store the new value permanently (set "01" in the register 48 **Command**).

You can see the number of bits used for the current singleturn resolution at the register 56 **N° of bits used for singleturn resolution**.

Default = 10 00 00h (1,048,576 cpr, 20 bits)

Min. value: 00 00 01h

Max. value: 10 00 00h



### WARNING

After having entered a new value next to the **Information per revolution** registers, the system zero sets the preset, thus you need to set it again, if required.

### Number of revolutions

#### [4E - 4F, rw]

These registers allow to enter the desired number of revolutions (multiturn resolution). You are allowed to enter any value which is less than or equal to the default value. If you set a value greater than the maximum allowed value, then the parameter is forced to the default value.

The setting in the **Number of revolutions** registers will be active immediately after transmission. Use the **Save parameters on EEPROM** function to store the new value permanently (set "01" in the register 48 **Command**).

You can see the number of bits used for the current multiturn resolution at the register 57 **N° of bits used for multiturn resolution**.

Min. value: 00 01h (=1 revolution)

Max. value (not power of 2): FF FFh (=65,535 revolutions)

Max. value: 00 00h (=65,536 revolutions, 16 bits, Default)



### WARNING

The hexadecimal value 00 00h is intended to set the maximum number of revolutions you are allowed to enter, that is: 65,536 revolutions; the hexadecimal values comprised between 00 01h and FF FFh set the number of revolutions between 1 and 65,535 revolutions.

Thus:

00 00h = 65,536 revolutions

00 01h = 1 revolution

00 02h = 2 revolutions

...

07 D0h = 2,000 revolutions

...

08 00h = 2,048 revolutions

...

FF FFh = 65,535 revolutions



### WARNING

After having entered a new value next to the **Number of revolutions** registers, the system zero sets the preset, thus you need to set it again, if required.

**WARNING**

When the number of revolutions you set is greater than 4,096 (10 00h), if the encoder is turned off you are forbidden from turning the shaft more than 2,047 revolutions in either clockwise or counter-clockwise directions. Should this happen, the absolute position information will be lost.

**Preset****[50 ... 54, rw]****WARNING**

You are allowed to enter a value next to the **Preset** registers only if the **Enable preset** bit in the **Configuration** register is set to "1".

These registers allow the operator to set the Preset value. Preset function is meant to assign a certain value to a desired physical position of the encoder. The chosen physical position (i.e. the transmitted position value) will get the value set next to these registers and all the previous and following positions will get a value according to it. For instance, this can be useful for getting the zero point of the encoder and the zero point of the application to match. The preset value will be set for the position of the encoder in the moment when the command is sent through the **Save parameters and activate Preset** function of the **Command** register (or through the Zero setting/Preset input signal, see the section "4.4 Zero setting/Preset input" on page 15).

After having entered a value next to the **Preset** registers you can either save it without activating the preset function or both save and activate it at the same time. Use the **Save parameters on EEPROM** function (set "01" in the **Command** register) to save the new Preset value without activating it.

Use the **Save parameters and activate Preset** function (set "02" in the **Command** register) to both save and activate the new Preset value.

The Preset value you are allowed to enter depends on the overall set resolution and must be less than or equal to (**Information per revolution \* Number of revolutions**) - 1.

Default = 00 00 00 00 00h

Min. value: 00 00 00 00 00h

Max. value: 0F FF FF FF FFh

**NOTE**

We suggest setting the preset when the encoder shaft is in stop.

Preset register structure:

Register	50	51	52	53	54
	MSB	...	...	...	LSB
	$2^{35} - 2^{32}$	$2^{31} - 2^{24}$	$2^{23} - 2^{16}$	$2^{15} - 2^8$	$2^7 - 2^0$



## PRESET SETTING EXAMPLE

You want to set the following **Preset** value = 01 86 A0h = 100,000<sub>10</sub>

1. First of all you must enable the setting of the **Preset** registers by entering the value "0" next to the **Enable preset** bit of the **Configuration** register.
2. Enter the desired preset value (01 86 A0 h = 100,000<sub>10</sub>) next to this **Preset** parameter.
3. To save the new Preset value without activating it, you must use the **Save parameters on EEPROM** function in the **Command** register (set "01" in the **Command** register).
4. Otherwise, to both save and activate the new Preset value at the same time, you must use the **Save parameters and activate Preset** function in the **Command** register (set "02" in the **Command** register).

Function	ADDR	DATA Tx
Setting the Enable preset bit of the Configuration register	49, bit 2	0

Writing in the Preset register	50	00
	51	00
	52	01
	53	86
	54	A0

Save parameters on EEPROM function in the Command register	48	01
--	----	----

or

Save parameters and activate Preset function in the Command register	48	02
--	----	----



### WARNING

After having set the new counting direction or changed either the number of information per revolution or the number of revolutions it is necessary to set also a new preset.

If you set a new singleturn or multiturn resolution and a new preset value at the same time and then use the **Save parameters and activate Preset** function in order to activate the preset, please consider that the system stores the new resolution values, but zero sets the preset value. Thus you need to enter it again.

### Device type

[55, ro]

This register describes the type of device.

Default = 02h: multiturn rotary encoder with BiSS C interface (AMx36xx/4096-17-...)

### N° of bits used for singleturn resolution

[56, ro]

This register shows the number of bits used for the current singleturn resolution as set next to the **Information per revolution** parameter (registers 4B ... 4D).

Default = 14h (= 20 bits)

### N° of bits used for multiturn resolution

[57, ro]

This register shows the number of bits used for the current multiturn resolution as set next to the **Number of revolutions** parameter (registers 4E-4F).

Default = 10h (= 16 bits)

### Device ID

[78 ... 7D, ro]

These registers contain the Device ID. Refer also to the order code. Identification name is expressed in hexadecimal ASCII code.

Register	78	79	7A	7B	7C	7D
Hex	41	4D	49	37	32	xx
ASCII	A	M	I	7	2	x

Registers 78-79 = encoder model (AM = AMx36 model)

Registers 7A-7B = interface (I7 = BiSS C interface)

Register 7C = enclosure (2 = 36 mm diameter enclosure)

Register 7D = software version, see the example



**EXAMPLE**

If the value in the register 7D is "31" hex, then the software version is "1".

**Manufacturer ID**

[7E-7F, ro]

These registers contain the Manufacturer ID. Identification name is expressed in hexadecimal ASCII code.

Register	7E	7F
Hex	4C	69
ASCII	L	i

Li = Lika Electronic

**6.6 Application notes**

Data transmission:

Parameter	Value
Clock Frequency	min 200KHz, max 10MHz
BiSS time-out	Self-adaptable to the clock, 10 $\mu$ s max.

**6.7 Recommended BiSS input circuit**

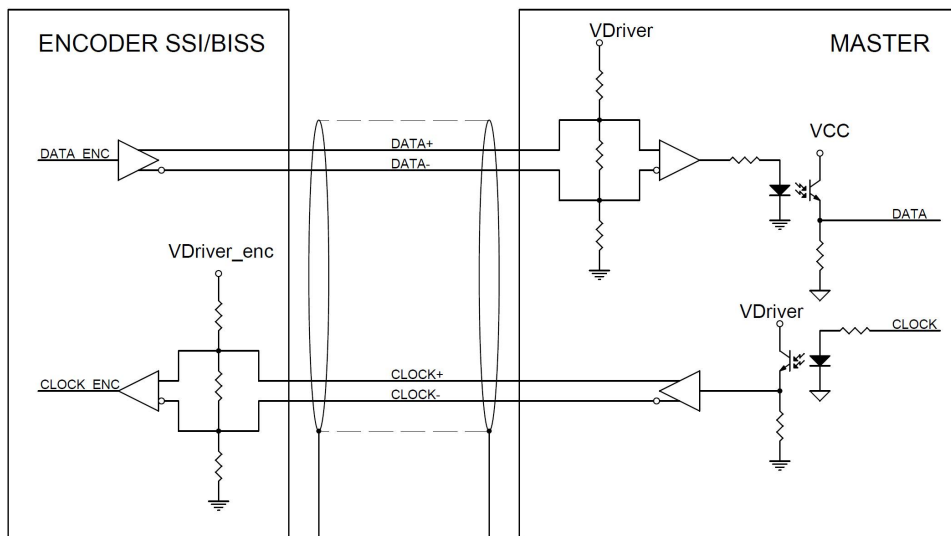



## 7 - Default parameters list

BiSS C-mode interface

Parameters list	Default value *		
Command	00		
Configuration	20		
Bit 0 not used	0		
Bit 1 not used	0		
Bit 2 Enable preset	0 = Enable		
Bit 3 not used	0		
Bit 4 not used	0		
Bit 5 Output code	1 = Binary		
Bit 6 Counting direction	0 = CW		
Bit 7 not used	0		
Information per revolution	10 00 00		
Number of revolutions	00 00		
Preset	00 00 00 00 00		

\* All values are expressed in hexadecimal notation.

This page intentionally left blank

This page intentionally left blank



Document release	Description
1.0	First issue

	This device is to be supplied by a Class 2 Circuit or Low-Voltage Limited Energy or Energy Source not exceeding 30 VDC. Refer to the ordering code for supply voltage rate.
---	---



Dispose separately

 **lika**

**Lika Electronic**

Via S. Lorenzo, 25 - 36010 Carrè (VI) - Italy

Tel. +39 0445 806600

Fax +39 0445 806699

Italy : eMail [info@lika.it](mailto:info@lika.it) - [www.lika.it](http://www.lika.it)

World : eMail [info@lika.biz](mailto:info@lika.biz) - [www.lika.biz](http://www.lika.biz)